

(19) World Intellectual Property Organization
International Bureau



(43) International Publication Date
16 February 2006 (16.02.2006)

PCT

(10) International Publication Number
WO 2006/015953 A1

(51) International Patent Classification⁷: **F17C 13/04**

(74) Agent: **DE CUENCA, Emmanuel**; 75, Quai d'Orsay, F-75007 PARIS (FR).

(21) International Application Number:
PCT/EP2005/053700

(81) Designated States (unless otherwise indicated, for every kind of national protection available): AE, AG, AL, AM, AT, AU, AZ, BA, BB, BG, BR, BW, BY, BZ, CA, CH, CN, CO, CR, CU, CZ, DE, DK, DM, DZ, EC, EE, EG, ES, FI, GB, GD, GE, GH, GM, HR, HU, ID, IL, IN, IS, JP, KE, KG, KM, KP, KR, KZ, LC, LK, LR, LS, LT, LU, LV, MA, MD, MG, MK, MN, MW, MX, MZ, NA, NG, NI, NO, NZ, OM, PG, PH, PL, PT, RO, RU, SC, SD, SE, SG, SK, SL, SM, SY, TJ, TM, TN, TR, TT, TZ, UA, UG, US, UZ, VC, VN, YU, ZA, ZM, ZW.

(22) International Filing Date: 28 July 2005 (28.07.2005)

(25) Filing Language: English

(26) Publication Language: English

(30) Priority Data:
2004-234535 11 August 2004 (11.08.2004) JP

(71) Applicant (for all designated States except US): **L'AIR LIQUIDE Société Anonyme à Directoire et Conseil de Surveillance pour l'Etude et l'Exploitation des Procédés Georges Claude** [FR/FR]; 75, Quai d'Orsay, F-75007 PARIS (FR).

(84) Designated States (unless otherwise indicated, for every kind of regional protection available): ARIPO (BW, GH, GM, KE, LS, MW, MZ, NA, SD, SL, SZ, TZ, UG, ZM, ZW), Eurasian (AM, AZ, BY, KG, KZ, MD, RU, TJ, TM), European (AT, BE, BG, CH, CY, CZ, DE, DK, EE, ES, FI, FR, GB, GR, HU, IE, IS, IT, LT, LU, LV, MC, NL, PL, PT, RO, SE, SI, SK, TR), OAPI (BF, BJ, CF, CG, CI, CM, GA, GN, GQ, GW, ML, MR, NE, SN, TD, TG).

(72) Inventors; and

(75) Inventors/Applicants (for US only): **HARADA, Kohsaku** [JP/JP]; **UTAKA LIMITED**, 5-17-5 Kugahara, Ota-ku, TOKYO (JP). **KIKUCHI, Toshiaki** [JP/JP]; **HAMAI INDUSTRIES LIMITED**, 1-3 Nishihara-cho, Fuchu Shi, TOKYO (JP). **SAKAI, Taku** [JP/JP]; **JAPAN AIR GASES**, 9-1 Shinonome 1-chome Koto ku, TOKYO, 1350062 (JP). **SHINDO, Manabu** [JP/JP]; **JAPAN AIR GASES**, 1-9-1 Shinonome 1-chome Koto ku, TOKYO, 1350062 (JP).

Declaration under Rule 4.17:

— as to the applicant's entitlement to claim the priority of the earlier application (Rule 4.17(iii)) for all designations

[Continued on next page]

(54) Title: CYLINDER VALVE

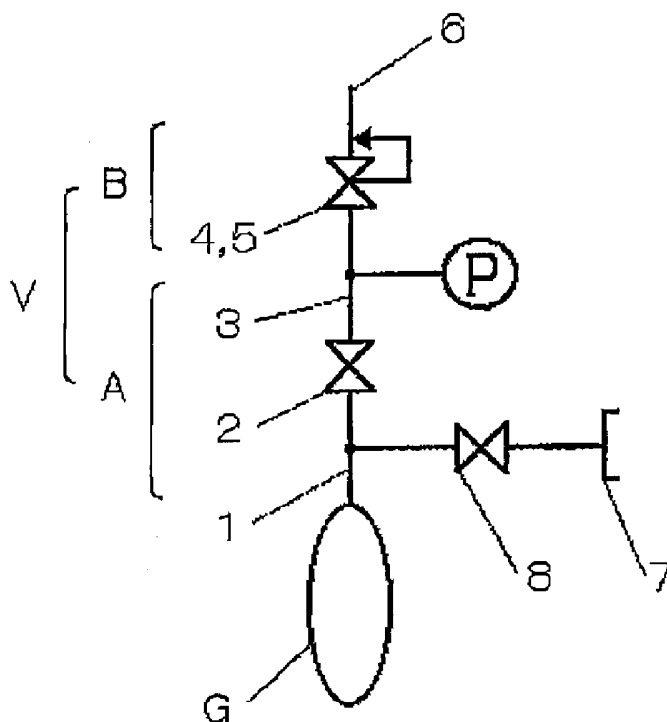

(57) Abstract: To develop a cylinder valve for small-sized gas cylinders that maintains gas purity during filling, and is sufficiently reduced in size and weight so that the gas cylinder remains balanced and can stand upright on its own when the valve is attached to the cylinder. The problem is solved by cylinder valve B, which is designed to be used when attached to gas cylinder G. The characteristic property of this valve is that it includes a shut-off valve A on the upstream side where the valve attaches to the cylinder, and an integrated pressure reducing valve B on the downstream side. A further characteristic is that the shut-off valve A describe above bifurcates the flow channel from where the cylinder valve attaches to the gas cylinder, and the shut-off component 2 which controls the opening and closing of the flow channel, as well as the filling port and sealing valve used when filling the cylinder, and the safety valve which prevents the pressure within the cylinder from exceeding the pressure resistance capacity are installed along the branches of this bifurcated flow channel.

WO 2006/015953 A1



Published:

— *with international search report*

For two-letter codes and other abbreviations, refer to the "Guidance Notes on Codes and Abbreviations" appearing at the beginning of each regular issue of the PCT Gazette.

CYLINDER VALVE

The present invention pertains to cylinder valves for use primarily with small-sized gas cylinders of 1L or 3.4L capacity filled with high-purity gases or with standard gases for analytical use.

Conventionally, high-pressure gas cylinders have been equipped with cylinder valves consisting of an integrated shut-off valve and safety valve, and also with a separate independent pressure-reducing valve. Recently, however, in the medical and industrial fields, space restrictions have stimulated the development of more compact devices, and cylinder valves that incorporate pressure reducing valve functions have now come into use. Fully integrated cylinder valves incorporating pressure reducing valve functions are now available for use with small-sized gas cylinders, particularly in the medical field, and the fill port of these valves generally consists of a check valve with an O-ring seal (for example, see cited patent documents 1 and 2).

However, it has also been proposed to use an ordinary valve rather than a check valve as the fill valve (for example see cited patent documents 3 and 4).

[Patent document 1] Published unexamined patent application H5-39898

[Patent document 2] Published unexamined patent application 2003-166700

[Patent document 3] Published unexamined patent application 2000-257797

[Patent document 4] Published unexamined patent application 2003-316447

However, most small-sized cylinder valves with integrated pressure reducing valve functions use a check valve mechanism with an O ring at the gas fill port. Although this does not present a problem under ordinary conditions, leaks may occur when filling cylinders with various types of highly permeating gases for analytical use such as He or H₂.

On the other hand, if an ordinary valve is used as the filling valve in place of a check valve mechanism, there is a danger that the gas supply valve may be operated by mistake, releasing highly pressurized gas while the gas is in use, without any reduction in pressure. Moreover, as this method requires the use of a handle for opening and closing, it was difficult to achieve reductions in overall size.

The purpose of the present invention is to provide a cylinder valve which has the following characteristics: it includes an integrated pressure reducing valve

for use with small gas cylinders of 1L or 3.4L capacity filled primarily with standard gas or highly purified gases for analytical uses; it is capable of maintaining gas quality during filling; and it is compact and lightweight enough to enable the gas cylinder to remain balanced and upright when the valve is attached.

5 The inventors dedicated themselves to research aimed at solving the problems referenced above, and as a result they were able to invent and perfect a cylinder valve as described below that has succeeded in fulfilling the objectives described.

10 The present invention is a cylinder valve that is designed to be attached to a gas cylinder. Its distinguishing characteristic is that it is an integrated valve consisting of a shut off valve on the upstream side where the cylinder valve attaches to the gas cylinder, as well as a pressure reducing valve placed on the downstream side. When this valve mechanism is attached to a high-pressure gas cylinder, the high-pressure gas in the cylinder can be supplied at the appropriate
15 reduced pressure by means of operating the cylinder valve. Another special feature of the invention is that its integrated structure allows the size and weight of cylinder valve as a whole to be reduced significantly, thus facilitating the autonomous use of the valve. This is especially true in cases where the pressure is reduced to a fixed level because with this valve there is no need for a secondary
20 pressure regulating mechanism. As a result so this invention makes it possible to supply a highly autonomous cylinder valve.

 As regards the cylinder valve described above, the shut-off valve mentioned previously bifurcates the flow channel at the upstream side of the cylinder valve, where it attaches to the cylinder, and a characteristic feature of this cylinder valve
25 is that the shut-off component that controls the opening and closing of the flow channels, the filling port and sealing valve for filling the gas cylinder, and the safety valve for preventing the pressure from exceeding the pressure resistance capacity of the cylinder are all installed along the bifurcated channel. This construction reduces dead space to a minimum and allows for smaller flow
30 channels, and therefore the cylinder valve as a whole can be made more compact and lighter than conventional valves. As a result, even when the cylinder valve is attached to a gas cylinder the valve remains balanced and autonomous.

A characteristic of the cylinder valve described above is that the sealing valve mentioned earlier opens and closes by means of a nut, and may be a packing type valve, a keyplate valve, or a diaphragm type valve. The use of these types of valve structures makes it possible to maintain gas purity when filling the cylinder through the filling port with highly purified or standard gases, and once the filling is completed the valve mechanism can be shut off without leaks. Further, because the sealing valve is operated by means of a nut rather than by a handle, it cannot be operated except when filling the cylinder, and when the cylinder is in use there are no protruding parts, thus achieving a safer and more compact valve design.

As described above, this invention consists of a cylinder valve that includes an integrated pressure reducing valve, and which, when attached to small 1L or 3.4L gas cylinders filled with highly purified or standard gases primarily for analytical uses, creates a high-pressure gas cylinder that is highly portable and very suitable for uses such as on-site analysis. Further, with this invention it is possible to fill the cylinder with no loss in gas purity, and because this device makes it possible to avoid leaks and emissions from the filling port, it allows gas to be supplied safely.

We will explain below the mode for carrying out the claims of the invention, using several Figures as reference materials.

Figure 1 is a schematic drawing illustrating the cylinder valve V pertinent to the invention described herein when attached to gas cylinder 'G'. The high-pressure gas in gas cylinder G passes through outlet port 1, shut-off component 2, connector 3, primary decompression component 4, and secondary decompression component 5, and is supplied via the supply port 6. In addition, the cylinder can be filled by passing the gas through the filling port 7, sealing valve 8, and outlet port 1.

As illustrated more concretely in Figure 2, the cylinder valve in question consists of a shut-off valve A and pressure-reducing valve B. The cylinder valve is attached to a gas cylinder (G) and fixed in place by pressing and turning it into the threaded socket on the gas cylinder (not shown). At this time the pressure-reducing valve B will have already been set to the specified pressure, but because the shut off valve A and the pressure-reducing valve B are integrated, the

connectors or related components that need to be attached to each of these valves in conventional designs are no longer necessary, and the cylinder valve V as a whole may be reduced in size and weight. Gas cylinder G can be filled through shut-off valve A with a wide variety of different types of gases, including liquefied gases, low pressure filler gases, or gases with high permeability, corrosive gases, or toxic gases. To use the high-pressure gas, shut-off valve A is opened, the high-pressure gas passes through shut-off valve A to pressure-reducing valve B, where the pressure is reduced to the appropriate level, and is then supplied from cylinder valve V.

10 It is preferable here that the cylinder valve V should be made of stainless steel because of its superior ability to maintain the purity of the filled gas, and its compatibility for use with standard gases, including reactive gases, but depending on the type of gas used, in order to fulfill the above conditions it is also possible to use aluminum alloy or brass.

15 The shut-off valve A consists of the following major components: cylinder attachment member (9) with external threaded piece that fits by insertion into the threaded connector socket on the cylinder, handle (10) to turn the gas on and off, component to shut off the flow channel (2), the filling port (7) where gas is introduced into the gas cylinder (G), and its sealing valve (8), and a safety valve
20 (11) to prevent pressure from exceeding the pressure resistance capacity. The flow channel from the gas cylinder (G) is bifurcated, and the shut-off component (2), the sealing valve (8), and safety valve (11) are installed on one branch of the bifurcated flow channel.

In other words, when filling gas cylinder (G) with high-pressure gas, the gas
25 passes through the filling port (7) and the gas outlet (1) that is provided within the cylinder attachment component (9), and when the filling is completed, the sealing valve (8) is forced shut, closing off the flow channel from the filling port (7) and maintaining an airtight seal. Sheet 8a is installed at the tip of sealing valve (8) and the force imparted by the bifurcated flow channel on this sheet helps to improve
30 the quality of the flow channel seal. The strength of the seal can be further improved by installing an O-ring or packing in the channel between 8a and the filling port (7), or the inlet for sealing valve (8).

As described above, a characteristic feature of the present invention is that this cylinder valve (V) includes a shut-off valve (A) that features superior gas tightness when filling gas cylinder (G). As illustrated more concretely in Figure 2, it consists of the following components:

5 (1) With regard to sealing valve (8) that controls the opening and closing of the filling port (7), the illustration in Figure 2 shows the case of a packing-type valve. Sealing valve (8) is opened and closed by means of a hexagonal wrench. This makes it the valve more streamlined and eliminates the possibility that the valve could be operated at any time other than during filling, thus increasing the
10 safety of the valve.

(2) The shut-off component (2) uses a diaphragm-type construction (2a), which is less prone to leakage than an O-ring type seal.

(3) To prevent outgassing or accidental operation once the cylinder is filled it is desirable that nut 8b be installed at the tip of sealing valve (8). This is to make
15 it more difficult to operate the valve except when filling the cylinder, and to reduce the possibility of an accident caused by opening the filling port (7) while gas was in use, causing a release of highly pressurized gas. In particular, we have adopted a distinctive shape for nut 8b to further strengthen control over operation of filling
20 port (7).

Figure 3 shows the time-related changes in gas pressure for different types of filling ports when the original pressure after filling was 100. There is a significant difference in the time-related decline in gas pressure between the present invention using a diaphragm-type construction, and conventional products using O-ring-type check valves. This demonstrates that the present cylinder valve (V) is
25 not only lighter in weight and more compact in size, it is also capable of maintaining a gas tight seal at the filling port (7).

With regard to sealing valve (8), the packing-type described above is very appropriate, but a keyplate or diaphragm-type may also be used.

Further, once the cylinder is filled, should an emergency situation arise in
30 which the pressure in the cylinder increases beyond its pressure rating, as a safety measure the safety valve (11) will open to release the pressure. Considering the times when the cylinder is not in use, the safety valve (11) has been installed between the shut-off component (2) and the gas outlet (1). It is desirable to install

it on the branch of the flow channel opposite that which leads to the filling port (7) (sealing valve 8), and the shut-off component (2), sealing valve (8) and safety valve (11) should be installed along the flow channel from gas outlet (1).

The pressure reducing valve B consists mainly of the following components:
5 connector 3, which links it to shut-off valve A, primary pressure reduction component 4, secondary pressure reduction component 5, and supply port 6. It maintains the specified pressure by means of diaphragm 5a, which is connected to secondary pressure reduction member 5. By using primary pressure reduction member 4 to initially reduce the pressure, it is possible to maintain a higher level of
10 control accuracy at the secondary pressure reduction stage. In other words, this design reduces the influence of declines in supply pressure as the fill volume in the cylinder decreases, and the influence of decreases in the gas temperature as gas is supplied. The secondary pressure reducing component 5 can be constructed so that it is virtually unaffected by changes in fill volume. The
15 reduction in pressure after the gas passes through the primary pressure reducing component 4, and the regulated pressure controlled by means of secondary pressure reducing component 5 can be monitored by placing a pressure gauge (not shown) at location C in Figure 2 to measure the pressure in the flow channel.

At such times it is preferable that a structure be used that allows the
20 pressure reducing valve B to be removed from the cylinder valve V. Vessels containing fluids may be filled with fluids in various states ranging from liquefied gases to low-pressure gases, and may also contain gases with diverse characteristics as regards permeability, corrosiveness, and toxicity. As a result it may be necessary to change the pressure reducing valve to one that better
25 matches the optimal pressure setting, or it may be necessary to use gas connectors made from different materials. In consideration of such cases, by making it possible to remove the pressure reducing valve from the cylinder valve it is possible to construct a cylinder valve that can be used in a wider range of applications. In particular, this type of construction can easily be adopted in the
30 case of the present invention because the pressure-reducing valve is located downstream from the shut-off valve. Moreover, because the present cylinder valve is lighter and more compact than conventional valves the pressure-reducing

portion can use a diaphragm-type construction preset to the desired pressure, thus reducing to a minimum the amount of dead space when the gas is in use.

In other words, materials or components can easily be removed, added or changed according to the characteristics of the fill gas, as described above, and in addition this type of design makes it possible to clean or purify the flow channel. In order to maintain a wide range of possible applications it is not desirable to have to change the entire cylinder valve, which includes a sealing valve and safety valve and other components that basically do not need to be changed. Therefore, by placing the shut-off valve A on the upstream side where the cylinder valve attaches to the cylinder, and placing the sealing valve (8) and safety valve (11) along the flow channel downstream from shut-off valve A, the above described replacements or maintenance can be performed smoothly even when the cylinder valve is attached to the gas cylinder G.

As described above, the shut-off valve and the pressure-reducing valve in the present invention are of a diaphragm-type construction that achieves superior gas tightness and reduces dead space to a minimum when the gas is in use.

With regard to the types of gases that may be used in a gas cylinder G equipped with this type of cylinder valve, highly purified gases such as He, H₂, O₂, Ar, N₂, Xe, Ne, Kr, etc., as well as standard gases and mixed gases containing trace amounts of O₂, H₂, CO, CO₂, CH₄, SO₂, NH₃, NO, NO₂, H₂S, C₂H₄, C₃H₈, C₄H₁₀, or other volatile organic compounds may all be used.

We have to this point focused on valves for use with vessels containing gases, but it is clear that the present technology is not limited to this type of application. For example, it is also suitable for application with fluids in general, such as liquefied gases or other liquids.

[Figure 1] Schematic Drawing of the cylinder valve pertaining to the present invention when attached to a gas cylinder

[Figure 2] Explanatory Drawing of the specific form of the cylinder valve pertaining to the present invention

[Figure 3] Explanatory Drawing of the sealing characteristics of the cylinder valve pertaining to the present invention

CLAIMS

1. The claim is for a cylinder valve to be attached to a gas cylinder. The
5 distinctive characteristic of this cylinder valve is that it consists of a shut-off on the
upstream side where it attaches to the cylinder, and a pressure-reducing valve on
the downstream side.

2. The shut-off valve mentioned above bifurcates the flow channel from the
upstream side where the cylinder valve described in Claim 1 attaches to the
10 cylinder, and a characteristic feature of the cylinder valve referred to in Claim 1 is
that the shut-off component that controls the opening and closing of the flow
channel, the filling port and sealing valve used when filling the gas cylinder, and
the safety valve for preventing the cylinder pressure from exceeding the rated
capacity of the cylinder are all installed along the bifurcated channel.

15 3. The cylinder valve described in Claim 1 and Claim 2 has the
characteristic that the sealing valve mentioned above is opened and closed by
means of a nut and may be either a packing-type valve, a keyplate type valve, or a
diaphragm type valve construction.

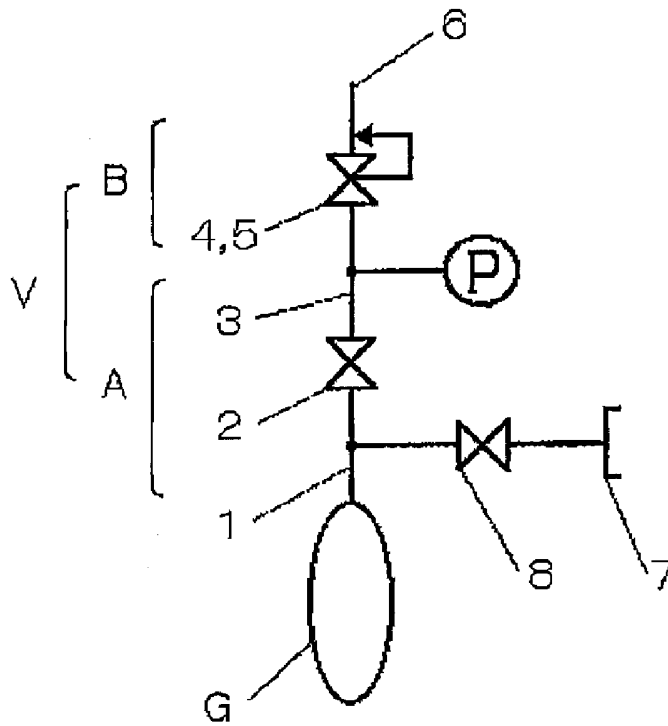
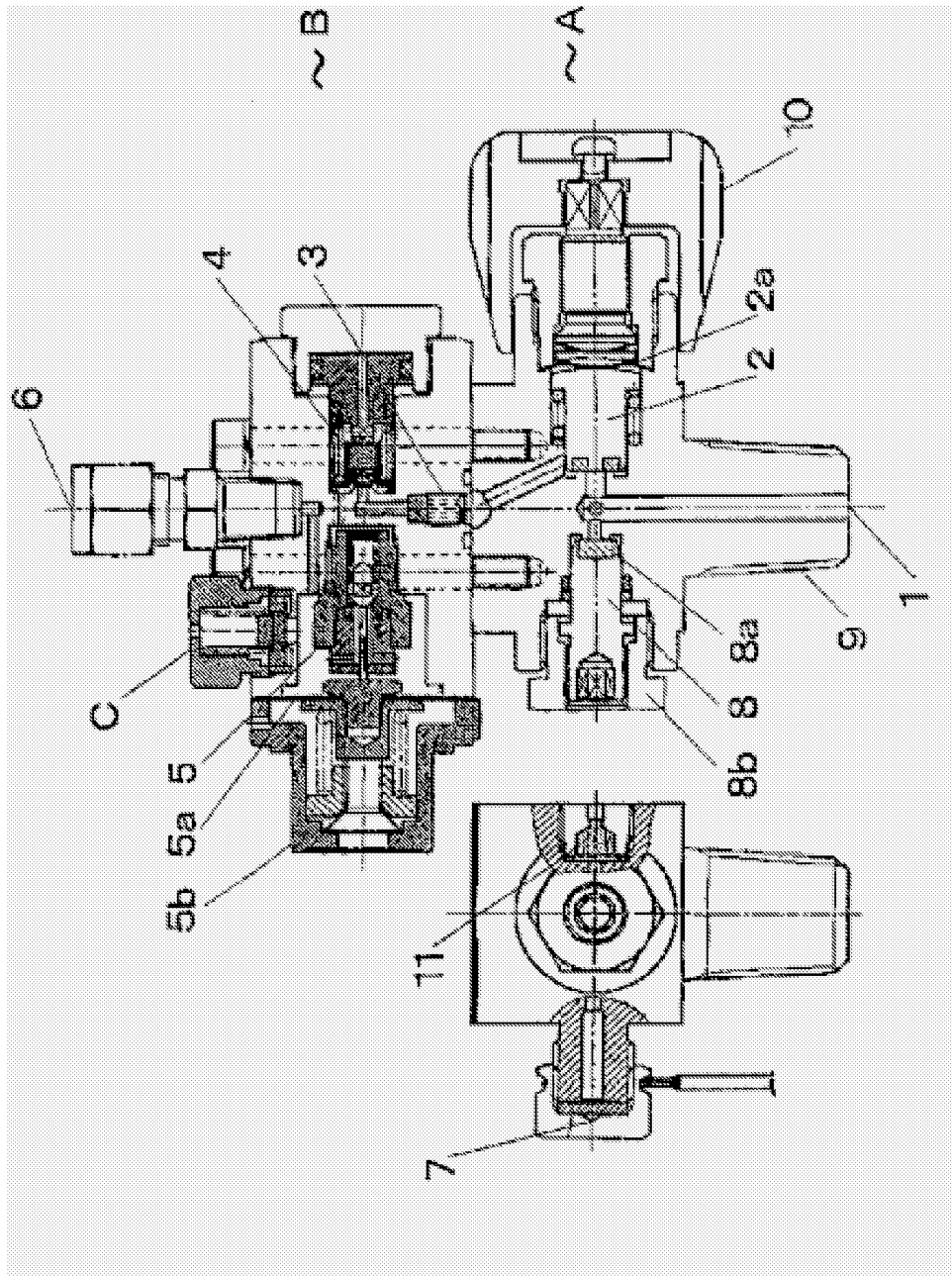

FIG. 1



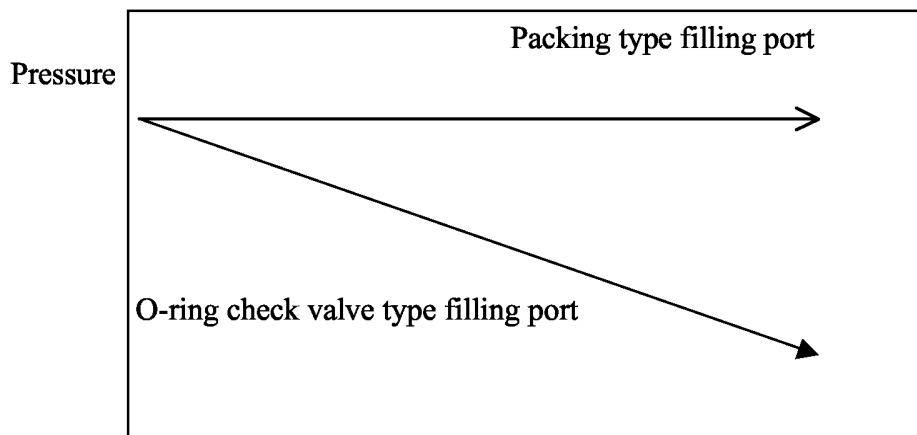

FIG. 3

INTERNATIONAL SEARCH REPORT

International Application No

PCT/EP2005/053700

A. CLASSIFICATION OF SUBJECT MATTER
IPC 7 F17C13/04

According to International Patent Classification (IPC) or to both national classification and IPC

B. FIELDS SEARCHED

Minimum documentation searched (classification system followed by classification symbols)

IPC 7 F17C

Documentation searched other than minimum documentation to the extent that such documents are included in the fields searched

Electronic data base consulted during the international search (name of data base and, where practical, search terms used)

EPO-Internal

C. DOCUMENTS CONSIDERED TO BE RELEVANT

Category °	Citation of document, with indication, where appropriate, of the relevant passages	Relevant to claim No.
X	EP 1 180 638 A (AIR PRODUCTS AND CHEMICALS, INC) 20 February 2002 (2002-02-20) the whole document	1-3
X	FR 2 796 124 A (L'AIR LIQUIDE SOCIETE ANONYME POUR L'ETUDE ET L'EXPLOITATION DES PROCE) 12 January 2001 (2001-01-12) the whole document	1-3
X	DE 101 46 457 A1 (MESSER CUTTING & WELDING GMBH) 24 April 2003 (2003-04-24) the whole document	1
X	EP 0 903 533 A (KABUSHIKI KAISHA NERIKI) 24 March 1999 (1999-03-24) the whole document	1
	-/--	

 Further documents are listed in the continuation of box C. Patent family members are listed in annex.

° Special categories of cited documents:

- *A* document defining the general state of the art which is not considered to be of particular relevance
- *E* earlier document but published on or after the international filing date
- *L* document which may throw doubts on priority claim(s) or which is cited to establish the publication date of another citation or other special reason (as specified)
- *O* document referring to an oral disclosure, use, exhibition or other means
- *P* document published prior to the international filing date but later than the priority date claimed

- *T* later document published after the international filing date or priority date and not in conflict with the application but cited to understand the principle or theory underlying the invention
- *X* document of particular relevance; the claimed invention cannot be considered novel or cannot be considered to involve an inventive step when the document is taken alone
- *Y* document of particular relevance; the claimed invention cannot be considered to involve an inventive step when the document is combined with one or more other such documents, such combination being obvious to a person skilled in the art.
- *Z* document member of the same patent family

Date of the actual completion of the international search

7 October 2005

Date of mailing of the international search report

18/10/2005

Name and mailing address of the ISA

European Patent Office, P.B. 5818 Patentlaan 2
NL - 2280 HV Rijswijk
Tel. (+31-70) 340-2040, Tx. 31 651 epo nl,
Fax: (+31-70) 340-3016

Authorized officer

Nicol, B

INTERNATIONAL SEARCH REPORT

International Application No

PCT/EP2005/053700

C.(Continuation) DOCUMENTS CONSIDERED TO BE RELEVANT

Category °	Citation of document, with indication, where appropriate, of the relevant passages	Relevant to claim No.
X	US 2001/052360 A1 (BRYSELBOUT FRANCIS) 20 December 2001 (2001-12-20) the whole document	1-3
P,X	US 2005/115987 A1 (BRUAT JOSYANE ET AL) 2 June 2005 (2005-06-02) the whole document	1
P,X	DE 298 25 115 U1 (GCE CHARLEDAVE, LA CHARITE SUR LOIRE) 3 March 2005 (2005-03-03) the whole document	1
X	US 6 009 900 A (ELGERT ET AL) 4 January 2000 (2000-01-04) the whole document	1
X	US 2002/124883 A1 (ZHENG DAO-HONG ET AL) 12 September 2002 (2002-09-12) the whole document	1
X	FR 2 802 281 A (L'AIR LIQUIDE SOCIETE ANONYME POUR L'ETUDE ET L'EXPLOITATION DES PROCE) 15 June 2001 (2001-06-15) the whole document	1

INTERNATIONAL SEARCH REPORT

Information on patent family members

International Application No

PCT/EP2005/053700

Patent document cited in search report		Publication date	Patent family member(s)	Publication date
EP 1180638	A	20-02-2002	CA 2354956 A1 CN 1340672 A JP 2002147696 A SG 99928 A1	18-02-2002 20-03-2002 22-05-2002 27-11-2003
FR 2796124	A	12-01-2001	NONE	
DE 10146457	A1	24-04-2003	NONE	
EP 0903533	A	24-03-1999	AU 8515698 A JP 11094197 A US 6047727 A	01-04-1999 09-04-1999 11-04-2000
US 2001052360	A1	20-12-2001	AU 777459 B2 AU 5007201 A BR 0102477 A CA 2351107 A1 CN 1329226 A EP 1167863 A1 FR 2810260 A1 JP 2002031299 A SG 95655 A1	14-10-2004 03-01-2002 19-02-2002 20-12-2001 02-01-2002 02-01-2002 21-12-2001 31-01-2002 23-04-2003
US 2005115987	A1	02-06-2005	AU 2002364795 A1 EP 1459007 A1 FR 2833861 A1 WO 03054441 A1	09-07-2003 22-09-2004 27-06-2003 03-07-2003
DE 29825115	U1	03-03-2005	NONE	
US 6009900	A	04-01-2000	AT 304146 T DE 19822369 A1 EP 0959292 A2	15-09-2005 25-11-1999 24-11-1999
US 2002124883	A1	12-09-2002	NONE	
FR 2802281	A	15-06-2001	NONE	