



(51) International Patent Classification:

E04H 4/00 (2006.01) *A63B 69/06* (2006.01)
A63B 69/00 (2006.01) *A63B 69/08* (2006.01)

(21) International Application Number:

PCT/US2017/037889

(22) International Filing Date:

16 June 2017 (16.06.2017)

(25) Filing Language:

English

(26) Publication Language:

English

(30) Priority Data:

62/351,783 17 June 2016 (17.06.2016) US

(72) Inventor; and

(71) Applicant: DAVIS, Allen Tanner [US/US]; 2524 Sheffield Avenue, Orlando, Florida 32806 (US).

(74) Agent: SAUER, Justin R.; Allen Dyer Doppelt & Gilchrist, 255 S. Orange Ave., Suite 1401, Orlando, Florida 32801 (US).

(81) Designated States (unless otherwise indicated, for every kind of national protection available):

AE, AG, AL, AM, AO, AT, AU, AZ, BA, BB, BG, BH, BN, BR, BW, BY, BZ, CA, CH, CL, CN, CO, CR, CU, CZ, DE, DJ, DK, DM, DO, DZ, EC, EE, EG, ES, FI, GB, GD, GE, GH, GM, GT, HN, HR, HU, ID, IL, IN, IR, IS, JO, JP, KE, KG, KH, KN, KP, KR, KW, KZ, LA, LC, LK, LR, LS, LU, LY, MA, MD, ME, MG, MK, MN, MW, MX, MY, MZ, NA, NG, NI, NO, NZ, OM, PA, PE, PG, PH, PL, PT, QA, RO, RS, RU, RW, SA,

SC, SD, SE, SG, SK, SL, SM, ST, SV, SY, TH, TJ, TM, TN, TR, TT, TZ, UA, UG, US, UZ, VC, VN, ZA, ZM, ZW.

(84) Designated States (unless otherwise indicated, for every kind of regional protection available):

ARIPO (BW, GH, GM, KE, LR, LS, MW, MZ, NA, RW, SD, SL, ST, SZ, TZ, UG, ZM, ZW), Eurasian (AM, AZ, BY, KG, KZ, RU, TJ, TM), European (AL, AT, BE, BG, CH, CY, CZ, DE, DK, EE, ES, FI, FR, GB, GR, HR, HU, IE, IS, IT, LT, LU, LV, MC, MK, MT, NL, NO, PL, PT, RO, RS, SE, SI, SK, SM, TR), OAPI (BF, BJ, CF, CG, CI, CM, GA, GN, GQ, GW, KM, ML, MR, NE, SN, TD, TG).

Published:

— with international search report (Art. 21(3))

(54) Title: SYSTEM AND METHOD OF GENERATING WAVE

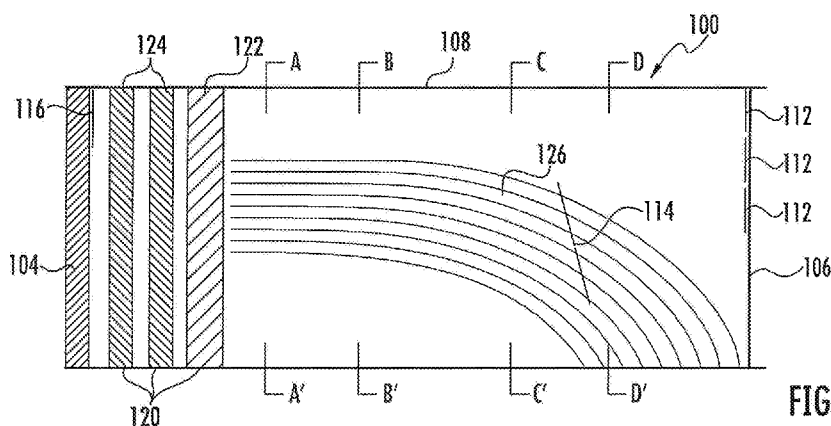

FIG. 1

(57) Abstract: A wave-forming system includes a channel having a water Inlet and a water outlet for directing water from the water inlet and the water outlet. The channel has a side wall and a bottom surface profile that slopes downward toward the water outlet and the side wall. The system also includes a back pressure barrier positioned in the water outlet to introduce a back pressure to the water flow inside the channel to continuously form waves across the channel.



SYSTEM AND METHOD OF GENERATING WAVE

Cross-Reference to Related Application

[0001] This application claims the benefit of U.S. Provisional Patent Application Serial No. 62/351,783 filed on June 17, 2016, the contents of which are herein incorporated by reference in their entirety.

Field of the Invention

[0002] The present invention relates to wave generating systems, and more particularly, to a wave generating system for generating waves suitable for surfers and other wave-riding sports.

Background of the Invention

[0003] Interest in the sport of surf-riding has increased at a rapid rate. As surfing and other wave-riding based sports have become more popular, demand for artificial waves has increased. While some attempts have been made to create artificial waves for surfers and other wave-riding sports, the waves created so far have not been able to simulate well the natural waves of these activities. The artificial waves created by current wave-generating apparatuses usually have limited shapes, sizes, speeds, and other features of wave profile or control thereof. Further improvements are possible for systems and methods of wave generation.

Summary of the Invention

[0004] In view of the foregoing, it is an object of the present invention to provide a system and method of generating artificial waves that are close mimics of natural waves. According to one embodiment of the invention, a wave-forming system includes a channel having a water inlet and a water outlet for directing water from the water inlet and the water outlet. The channel has a side wall and a bottom surface profile that slopes downward toward the water outlet and the side wall. The system also includes a back pressure barrier positioned in the water outlet to introduce a back pressure to the water flow inside the channel to continuously form waves across the channel.

[0005] According to another embodiment of the present invention, the method of generating waves provides a channel having a water inlet and a water outlet, a side wall, and a bottom surface profile that slopes downward toward the water outlet and the side wall. A water flow is directed from the water inlet to the water outlet. A back-pressure barrier is positioned in the water outlet to introduce a back pressure applied to the water flowing inside the channel. Waves are thus continuously formed across the channel.

[0006] These and other objects, aspects and advantages of the present invention will be better appreciated in view of the drawings and following detailed description of preferred embodiments.

Brief Description of the Drawings

- [0007] Figure 1 is a top view of a wave generating system illustrating a channel bottom surface profile, according to one embodiment of the present invention;
- [0008] Figure 2 is a side view of a wave generating system of Figure 1;
- [0009] Figure 3 is a cross-sectional view of the wave generating system of Figure 1 taken along line A-A';
- [0010] Figure 4 is another cross-sectional view of the wave generating system of Figure 1 taken along line B-B';
- [0011] Figure 5 is another cross-sectional view of the wave generating system of Figure 1 taken along line C-C';
- [0012] Figure 6 is another cross-sectional view of the wave generating system of the Figure 1 taken along line D-D';
- [0013] Figure 7 is a top view of a wave generating system, according to another embodiment of the present invention;
- [0014] Figure 8 is a side view of a wave generating system implemented in a river valley, according to another embodiment of the present invention;
- [0015] Figure 9 is a top view of the wave generating system of Figure 8;
- [0016] Figure 10 is a cross sectional view a wave generating system at water inlet, according to one embodiment of the present invention;

[0017] Figure 11 is a side view of a wave generating system having a cascade arrangement, according to another embodiment of the present invention; and

[0018] Figure 12 is a flow chart of method for generating waves, according to one embodiment of the present invention.

Detailed Description of the Preferred Embodiments

[0019] According to one embodiment of the present invention, referring to FIGS. 1-2, a wave-forming system 100 includes a channel 102 having a water inlet 104 and a water outlet 106 for directing water therebetween. The channel 102 has a side wall 108 and a bottom surface 110 having a surface profile that slopes downward toward the water outlet 106 and the side wall 108. The system 100 also includes a back-pressure barrier 112 positioned at the water outlet 106 to introduce a back pressure to the water flowing inside the channel 102 for the continuous formation of waves 114 across the channel 102.

[0020] One or more vector gates 116 can be positioned at certain locations at the water inlet 104 to further adjust water flow at the water inlet 104 to achieve a desired wave profile. In the depicted embodiment, a vector gate 116 is positioned in proximity to the sidewall 108 at the water inlet 104. The position and/or orientation of the one or more vector gates 116 can be adjusted via a gate controller 118.

[0021] One or more flow conditioners 120 such as filters 122 and/or vanes 124 can be implemented at the water inlet 104. For example, one or more filters

122 can be implemented at the water inlet 104 to provide a desired resistance to water flow and decrease water turbulence. As another example, one or more vanes 124 can be used to direct water flow to a desired direction as water passes through the water inlet 104. The water is preferably orientated toward the side wall 108 when flowing through the channel 102. The conditions of the water (e.g., flow speed, flow volume, hydraulic pressure, and flow laminate level, etc.) at the water inlet 104 will partially determine the wave profile (e.g., type, size, shape, speed, etc.) generated in the channel 102.

[0022] The bottom surface 110 is preferably smooth to facilitate laminar flow. The profile of the bottom surface 110 is indicated by bathymetry lines 126. As shown, bathymetry lines 126 illustrates that the bottom surface 110 slopes downward and toward the sidewall 108 at different rates, depending on locations of the channel 102. Example slopes can be in the 1:2 - 1:10 range. The slope of the bottom surface 110 can be adjusted to mimic the bathymetry of natural wave formation or to be custom designed to create a custom wave for surfers with diverse levels of experience. A shallow slope angle will create gentle waves, while a steeper slope angle will create waves that curl over to create an interior portion (e.g., barreling waves).

[0023] The back-pressure barrier 112 can create a back pressure to slow down a portion of water flow so that an upper layer of slow-moving water will meet with a lower layer of fast-moving water, thereby generating a hydraulic jump. The hydraulic jump can partially determine the form of waves, such as size, speed, and shape. The back-pressure barrier 112 can be extended perpendicular to the

direction of water flow, as shown in FIG. 1, or at angles relative to the direction of the water flow. Examples of the angles include +/- 0-5, 5-10, 10-15, 15-20, 20-25, 25-30, 35-40, 40-45, 45-50, 50-55, 55-60, 60-65, 65-70, 70-75, 75-80, and 80-85 degrees relative to the direction of water flow inside the channel 104. The back-pressure barrier 112 can be planar or include a curved surface (e.g., concave curve, convex curve, etc.). The dimension of the back-pressure barrier 112 will also partially influence the profile of the wave (e.g., size, speed, style).

[0024] The back-pressure barrier 112 can include one or more independently-positionable panels. The position and/or orientation of the back-pressure barrier 112 can be adjusted by a back-pressure barrier controller 126. By adjusting the position and/or orientation of the back-pressure barrier 112, the speed and orientation the hydraulic jump can be adjusted, thus producing the desired wave profile (e.g., style, size and speed, etc.).

[0025] Referring to FIGS. 3-6, four cross-sectional views of the bottom surface 110 and respective water line 128 along the channel 102 are shown. Specifically, the cross-sectional views along lines A-A', B-B', C-C', and D-D' show that the bottom surface 110 slopes downward toward the water outlet 106 and the sidewall 108 of the waving forming channel 102. The water lines 128 in these figures show how the water volume builds up and forms waves corresponding to the slope and longitudinal distance along the channel and toward the back-pressure barrier 112.

[0026] Referring to FIG. 7, according to another embodiment of the present invention, the channel 102 can also have two sidewalls 108A and 108B. The

bottom surface 110 slopes downward from a central axis of the channel 102 to both side walls 108A and 108B and from a longitudinal point on the channel 102 to the water outlet 106. As such, continuous wave 114A and 114B can be created at both sides of the channel 102 for multiple surfers to ride simultaneously.

[0027] Referring FIGS. 8-9, according to one embodiment of the present invention, a wave generating system 100 is implemented in downstream of a river valley 128. Specifically, the water inlet 104 of the channel 102 is positioned on a settling area 130 of the river valley 128 between dams 132. Water passing the water inlet 104 will have an adequate head pressure before entering the channel 102. This configuration can significantly reduce the energy cost of operating the system 100.

[0028] Referring to FIG. 10, a plurality of containers 132 can be used to store water before entering the channel 102. The plurality of containers 132 can be independently filled by a pump via respective pump outlets 134 or filled by natural water flow as shown in FIGS. 8-9. The hydraulic head (e.g., height) inside the plurality of containers 132 can be controlled independently to create a desired water line 128 at the water inlet 102. Each of the plurality of containers 132 can also include a hydraulic head regulator (not shown) configured to regulate a hydraulic head of the water inside the container 132. For example, the hydraulic head regulator can be an overflow gate to ensure certain amount of water remains at each of the plurality of container 132 to create a specific hydraulic head, but any component capable of regulating (e.g., increasing or decreasing) hydraulic head within the container 132 can be used.

[0029] Referring to FIG. 11, according to another embodiment of the present invention, a series of sets of wave-forming systems are installed in a cascading mode. Specifically, three sets of wave-generating systems 100A, 100B and 100C are positioned at three elevations such that a wave forming system (e.g., 100B) at a lower altitude can utilize the water flowing downward from a wave generating system (e.g., 100A) at a higher altitude. In other words, water released from the water outlet at a higher altitude is configured to be used as a water source for the system at a lower altitude. This arrangement can provide multiple wave sites in an energy efficient manner.

[0030] Referring to FIG. 12, a method of generating waves includes providing a channel having a water inlet and a water outlet, a side wall, and a bottom surface having a profile that slopes downward toward the water outlet and the side wall at step 1202. At step 1204, a water flow is directed from the water inlet and the water outlet. At step 1206, a back-pressure barrier is positioned for adjustable introduction of a back pressure to the water flow inside the channel. At step 1208, waves are formed continuously across the channel.

[0031] The wave generating system 100 is configurable. A plurality of variable the system 100 can be adjusted to achieve a desired type, shape, speed, and size of wave suitable for surfers of varying levels of surfing experience. Specifically, the variables include water condition (e.g., rate and volume) at the water inlet 104, water rate inside the wave-forming channel, depth and bottom surface profile of the channel 102, location, orientation, dimension, and shape of the back-pressure barrier 112. For example, by adjusting filters and vanes on the

water inlet 102, a desired flow condition can be achieved at the water inlet 102. As another example, the profile of the bottom surface 110 of the wave forming channel 102 can be made according to a specific bathymetry (e.g., steeper slope, shallower slope, etc.) to generate waves suitable for certain level of surfers.

Shallower slopes will allow the wave to slowly steepen and then crumble softly.

Steeper slopes can force the wave up quicker and the crumbles slide heavily down a steep face.

[0032] The wave-generating system 100 is simple to construct, easy to operate, easy to use and reliable. The system 100 can be used to teach surfing beginners the skills necessary for surf-riding without exposing them to dangers faced by experienced surfers, and the system 100 is readily modified to create waves for experienced surfers. The system 100 can also be used to provide an apparatus for testing boat models subjected to ocean wave conditions.

[0033] Many modifications and other embodiments of the invention will come to the mind of one skilled in the art having the benefit of the teachings presented in the foregoing descriptions and the associated drawings. Therefore, it is understood that the invention is not to be limited to the specific embodiments disclosed, and that modifications and embodiments are intended to be included within the scope of the appended claims.

WHAT IS CLAIMED IS:

1. A wave forming system comprising:
a channel having a water inlet and a water outlet for directing water from the water inlet and the water outlet, the channel having a side wall and a bottom surface profile that slopes downward toward the water outlet and the side wall; and
a back pressure barrier positioned in the water outlet to introduce a back pressure to the water flow inside the channel to continuously form waves across the channel.
2. The wave forming system of claim 1, wherein at least one vector gate is adjustably positioned at the water inlet.
3. The wave forming system of claim 1, wherein the water inlet includes a flow conditioner configured to control a flow condition of the water passing through the water outlet gate.
4. The wave forming system of claim 3, wherein the flow conditioner includes at least one filter configured to reduce turbulence at the water inlet.
5. The wave forming system of claim 3, wherein the flow conditioner includes at least one vane configured to adjust orientation of the water flow at the water inlet.

6. The wave forming system of claim 5, wherein the at least one vane is adjusted to orientate the water flow toward the sidewall.
7. The wave forming system of claim 1, wherein the system further includes a water source for supplying water to the water inlet.
8. The wave forming system of claim 7, wherein the water source includes at least one pump.
9. The wave forming system of claim 7, wherein the water source includes a gravity flow arrangement.
10. The wave forming system of claim 1, wherein the back pressure barrier includes a plurality of independently-positionable panels.
11. The wave forming system of claim 1, wherein the back pressure barrier is extends perpendicular to the direction of the water flow.
12. The wave forming system of claim 1, wherein the back pressure barrier is extends at an angle relative to the direction of the water flow.
13. The wave forming system of claim 1, wherein the back pressure barrier includes one or more panels.

14. The wave forming system of claim 1, wherein the back pressure barrier includes a curved surface.
15. The wave forming system of claim 1, wherein the channel has two side walls and a bottom surface profile that slopes downward from a central axis of the channel to both side walls and from a longitudinal point on the channel to the water outlet, such that continuous wave are formed at both sides of the channel.
16. The wave forming system of claim 1, further comprising a second channel and a second back pressure barrier at a lower altitude, wherein the water inlet of the second channel is configured to receive water from the water outlet of the channel at a higher altitude.
17. A method for generating waves comprising:
- providing a channel having a water inlet and a water outlet, a side wall, and a bottom surface profile that slopes downward toward the water outlet and the side wall;
 - directing a water flow from the water inlet and the water outlet;
 - positioning a back pressure barrier in the water outlet to adjustably introduce a back pressure to the water flow inside the channel; and
 - continuously forming waves across the channel.

18. The method of claim 17, further comprising implementing a flow conditioner at the water inlet to control a flow condition at the water inlet.
19. The method of claim 17, wherein implementing a flow conditioner includes implementing at least one filter to reduce flow turbulent at the water inlet.
20. The method of claim 17, wherein implementing a flow conditioner includes implementing at least one vane to orientate the water flow toward the side wall.
21. The method of claim 17, further comprising adjusting at least one or more of number and position of the back pressure barrier to form a specific wave.
22. The method of claim 17, further comprising adjusting the slope profile of the bottom surface to form a specific wave.
23. The method of claim 17, wherein the channel has two side walls and a bottom surface profile that slopes downward from a central axis of the channel to both side walls and from a longitudinal point on the channel to the water outlet, such that continuous wave are formed at both sides of the channel.
24. The method of claim 17, further comprising:
 - providing a second channel at a lower altitude, the second channel having a water inlet and a water outlet, a side wall, and a bottom surface profile that slopes

downward toward the water outlet and the side wall, wherein the water inlet of the second channel is positioned to receive water from water outlet of the channel at a higher altitude;

directing a water flow from the water inlet and the water outlet of the second channel;

positioning a back pressure barrier in the water outlet of the second channel to adjustably introduce a back pressure to the water flow inside the channel; and

continuously forming waves across the second channel.

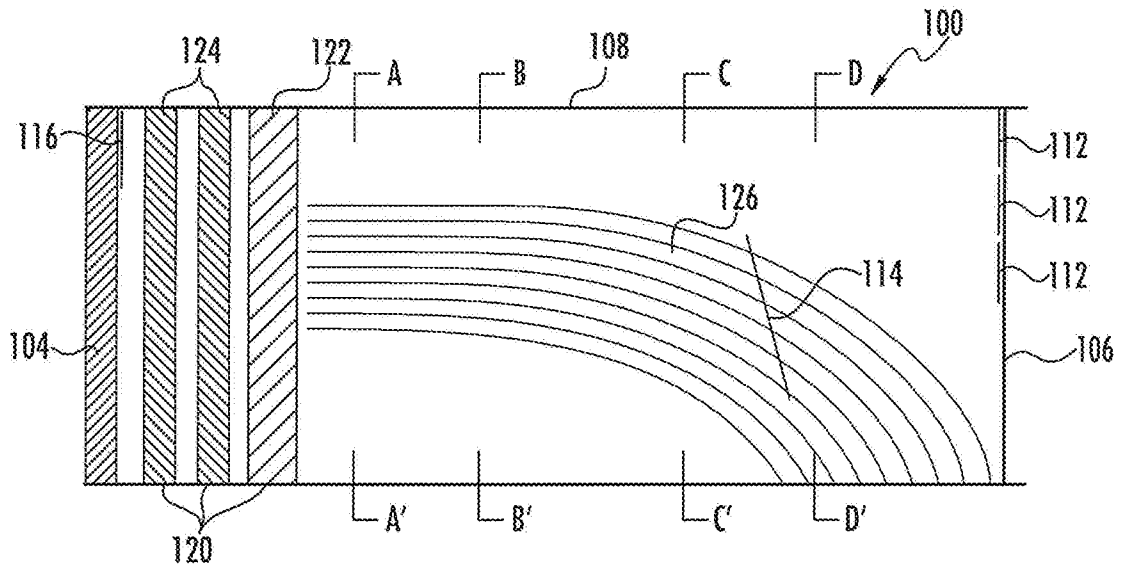

FIG. 1

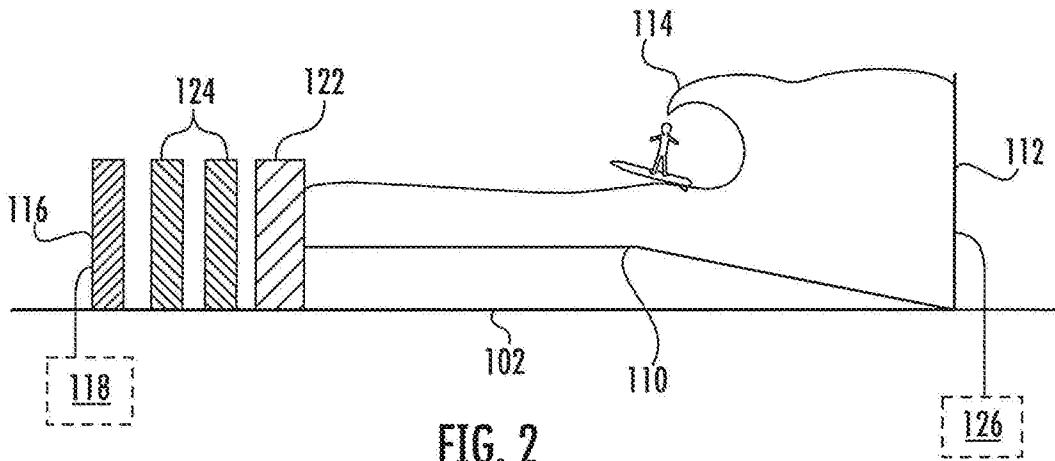
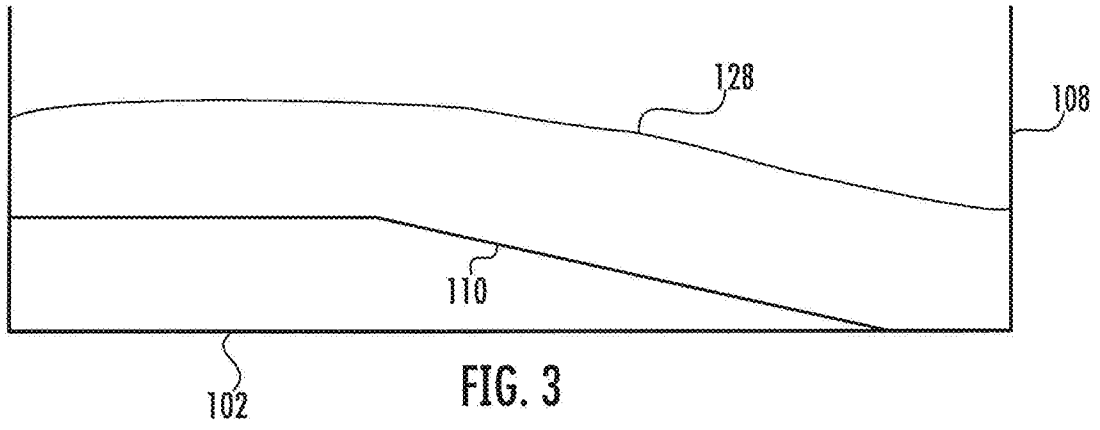

FIG. 2

2/10



3/10

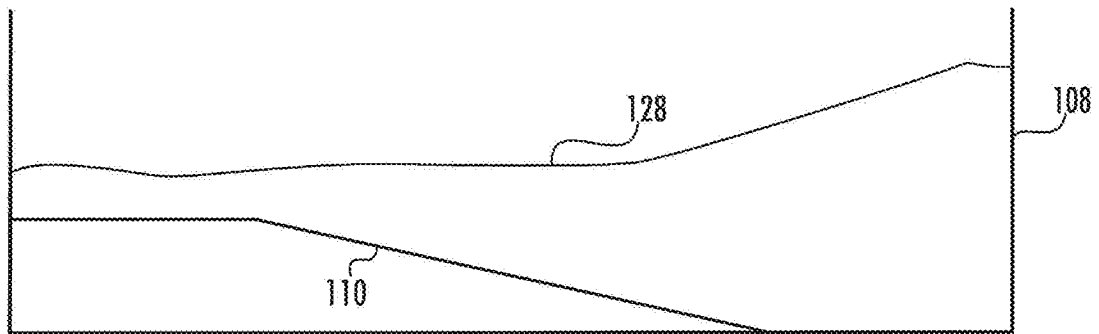
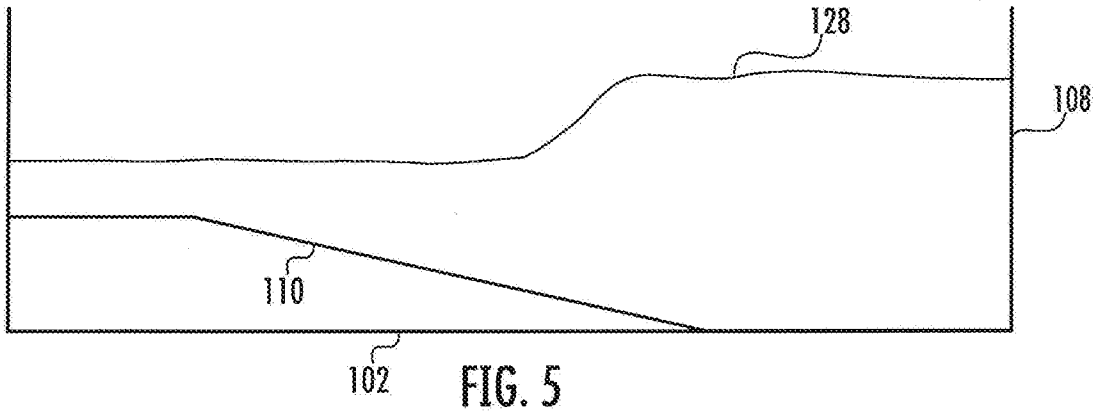

FIG. 4

4/10



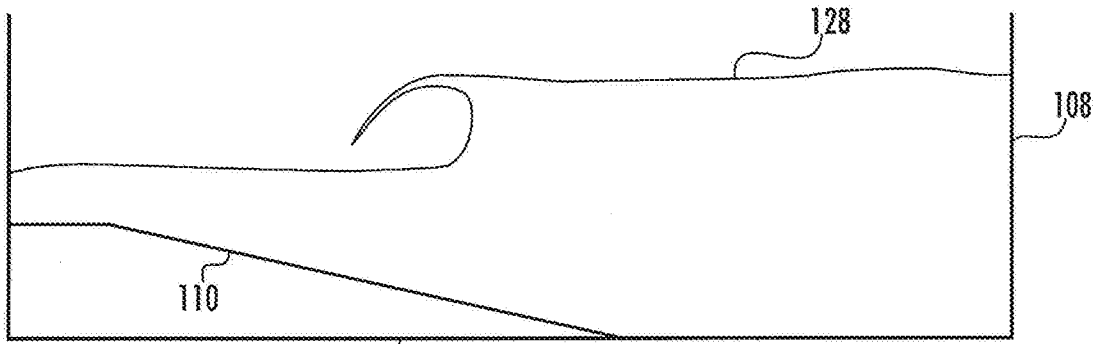

FIG. 6

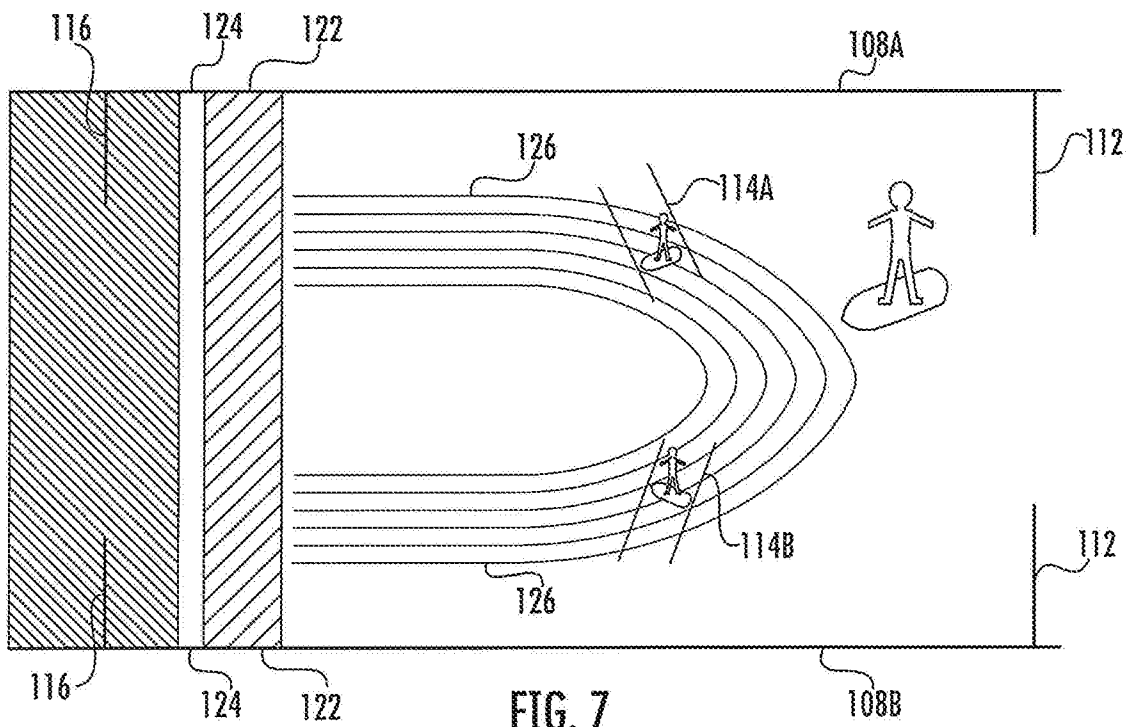

FIG. 7

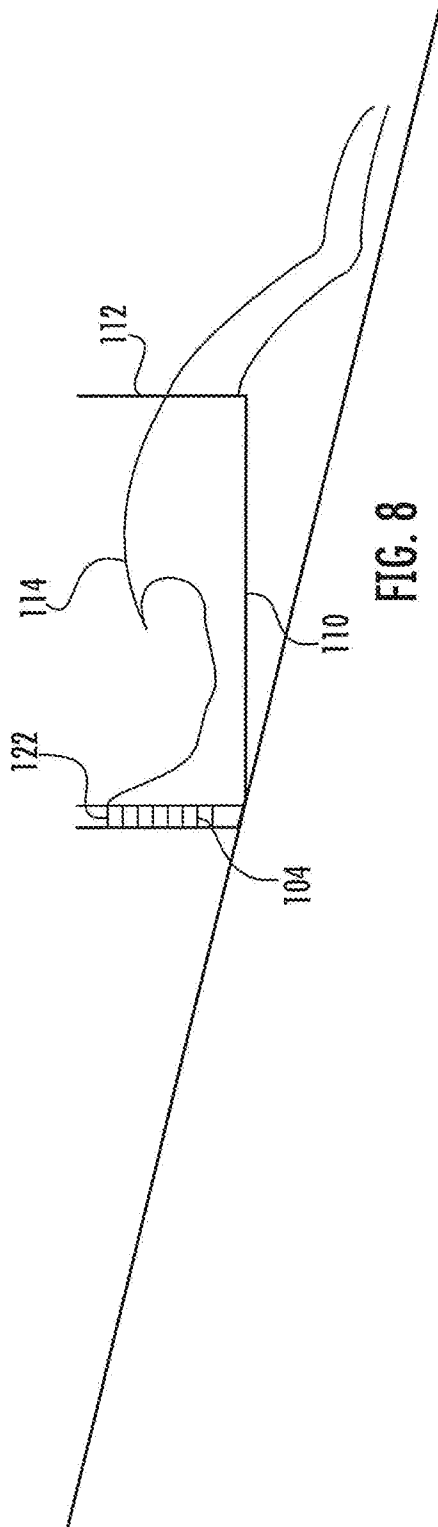

FIG. 8

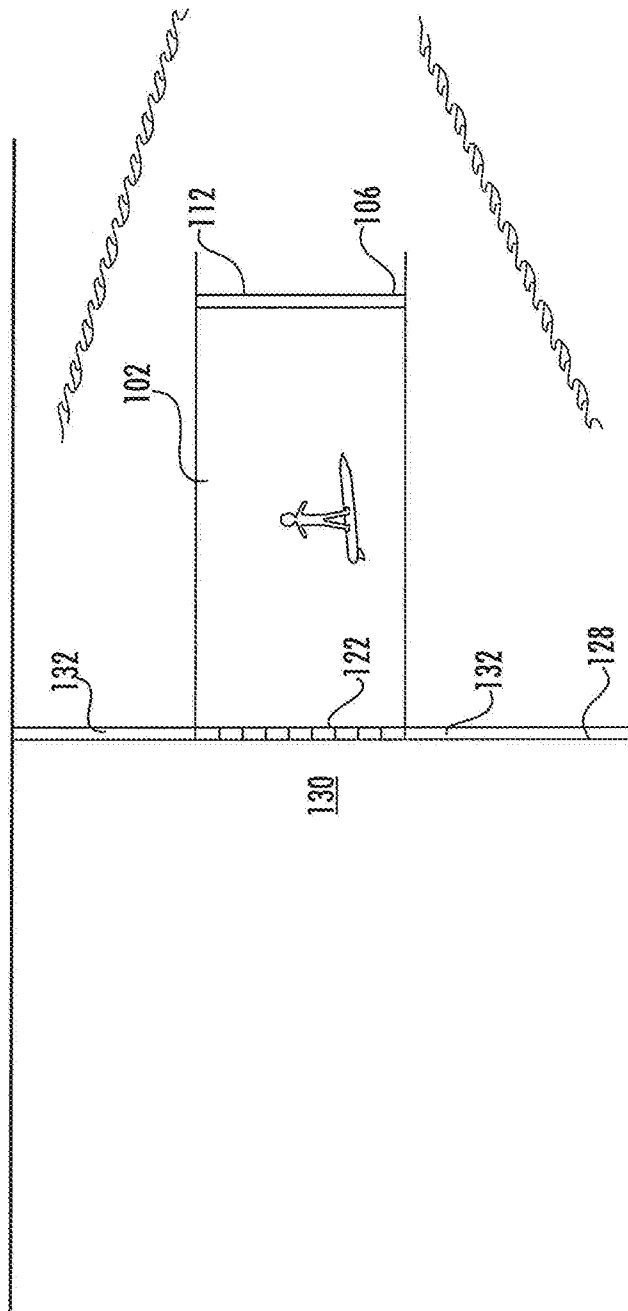

FIG. 9

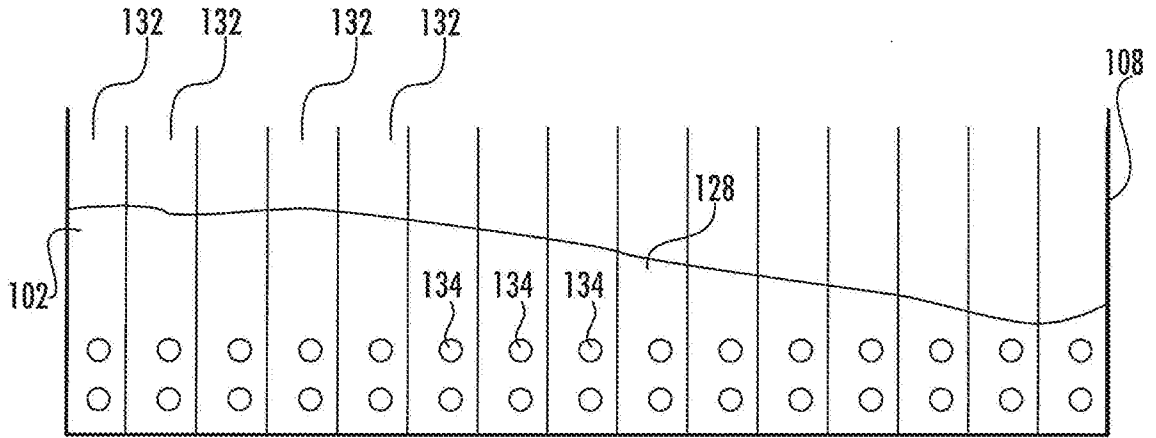

FIG. 10

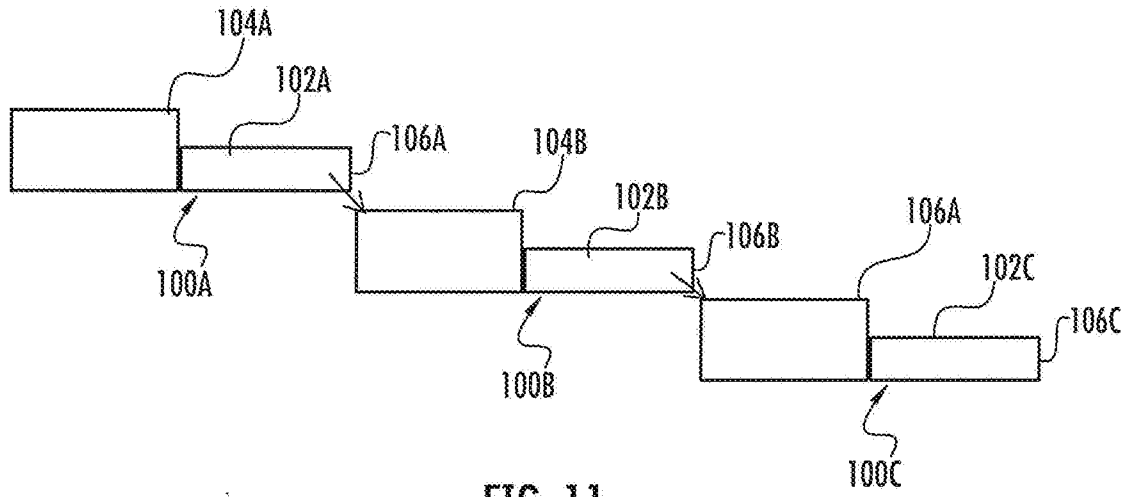

FIG. 11

10/10

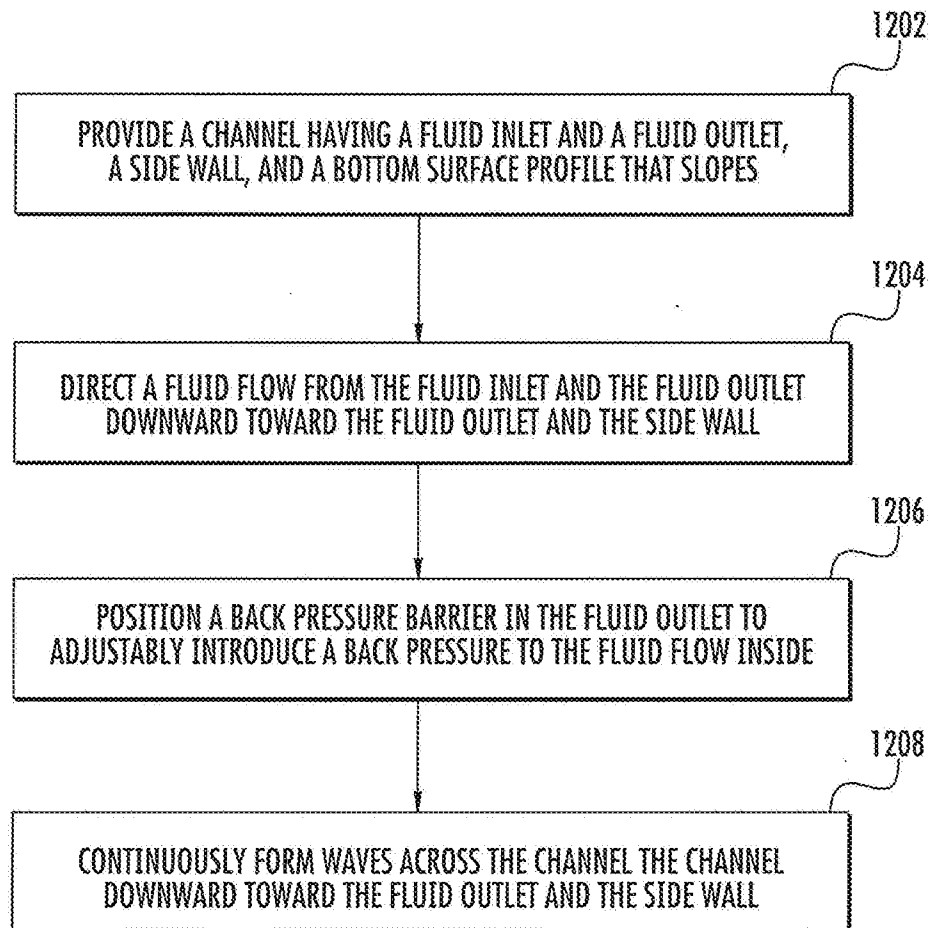

FIG. 12

INTERNATIONAL SEARCH REPORT

International application No.

PCT/US 17/37889

A. CLASSIFICATION OF SUBJECT MATTER
 IPC(8) - E04H 4/00; A63B 69/00, 69/06, 69/08 (2017.01)
 CPC - E04H 4/0006; A63B 69/0093, 69/00, 69/06, 69/08; A63C 19/00; A63G 3/00, 31/007; E04H 4/00

According to International Patent Classification (IPC) or to both national classification and IPC

B. FIELDS SEARCHED

Minimum documentation searched (classification system followed by classification symbols)

See Search History Document

Documentation searched other than minimum documentation to the extent that such documents are included in the fields searched

See Search History Document

Electronic data base consulted during the international search (name of data base and, where practicable, search terms used)

See Search History Document

C. DOCUMENTS CONSIDERED TO BE RELEVANT

Category*	Citation of document, with indication, where appropriate, of the relevant passages	Relevant to claim No.
X --- Y	US 2008/0089744 A1 (McFarland) 17 April 2008 (17.04.2008), Figs. 1-6, para [0021]-[0022], [0034]-[0035]	1-4, 7-10, 12-15, 17-19 and 21-23 ----- 5-6, 11, 16, 20 and 24
Y	US 2012/0201605 A1 (Hill) 09 August 2012 (09.08.2012), Fig. 3a, para [0126]	5-6 and 20
Y	US 4,905,987 A (Frenzi) 06 March 1990 (06.03.1990), Fig. 8; col. 7, ln. 24-59	11, 16 and 24
A	US 2011/0099707 A1 (Klimaschewski) 05 May 2011 (05.05.2011), Figs. 1-3, para [0027]-[0035]	1-24
A	WO 2013/083259 A2 (Meyer-Berhorn) 13 June 2013 (13.06.2013), Figs. 2-4, pg. 10, ln. 1 - pg. 12, ln. 6	1-24

Further documents are listed in the continuation of Box C.

See patent family annex.

* Special categories of cited documents:

"A" document defining the general state of the art which is not considered to be of particular relevance

"E" earlier application or patent but published on or after the international filing date

"L" document which may throw doubts on priority claim(s) or which is cited to establish the publication date of another citation or other special reason (as specified)

"O" document referring to an oral disclosure, use, exhibition or other means

"P" document published prior to the international filing date but later than the priority date claimed

"T" later document published after the international filing date or priority date and not in conflict with the application but cited to understand the principle or theory underlying the invention

"X" document of particular relevance; the claimed invention cannot be considered novel or cannot be considered to involve an inventive step when the document is taken alone

"Y" document of particular relevance; the claimed invention cannot be considered to involve an inventive step when the document is combined with one or more other such documents, such combination being obvious to a person skilled in the art

"&" document member of the same patent family

Date of the actual completion of the international search

17 August 2017

Date of mailing of the international search report

12 SEP 2017

Name and mailing address of the ISA/US

Mail Stop PCT, Attn: ISA/US, Commissioner for Patents
 P.O. Box 1450, Alexandria, Virginia 22313-1450
 Facsimile No. 571-273-8300

Authorized officer:

Lee W. Young

PCT Helpdesk: 571-272-4300
 PCT OSP: 571-272-7774