



US 20140014611A1

(19) **United States**

(12) **Patent Application Publication**
Buehler et al.

(10) **Pub. No.: US 2014/0014611 A1**

(43) **Pub. Date: Jan. 16, 2014**

(54) **CHILD-RESISTANT CAP FOR LIQUID
MEDICAMENTS**

Publication Classification

(71) Applicant: **COMAR, INC.**, Buena, NJ (US)

(51) **Int. Cl.**
B65D 50/02 (2006.01)

(72) Inventors: **John D. Buehler**, Bridgeton, NJ (US);
John B. Daly, Ocean City (IE); **Kevin A.
DiPlacido**, Williamstown, NJ (US);
Redd J. Harold, Ocean View, NJ (US);
David T. Kershner, Egg Harbor
Township, NJ (US); **David A. Manera**,
Buena, NJ (US); **Timothy K. Stangle**,
Linwood, NJ (US); **Russ Granato**,
Vineland, NJ (US)

(52) **U.S. Cl.**
CPC **B65D 50/02** (2013.01)
USPC **215/217; 53/492**

(57) **ABSTRACT**

An improved child-resistant closure for dispensers of liquid medicaments, the closure being of a two-part construction. The closure has an outer cap with a quantity of shoulder lugs and skirt lugs and an inner cap with a quantity of shoulder lugs and flexible beams. The closure has equal quantities of shoulder lugs on the inner and outer caps, equal quantities of skirt lugs and flexible beams, flexible beams having an arcuate underside, shoulder lugs having a depth to prevent hyperflexion of the flexible beams, and an ideal overlap when the faces of the shoulder lugs are aligned. Additionally, provided are methods for attaching and removing the cap from a pre-existing bottle.

(21) Appl. No.: **13/940,666**

(22) Filed: **Jul. 12, 2013**

Related U.S. Application Data

(60) Provisional application No. 61/671,194, filed on Jul. 13, 2012.

100

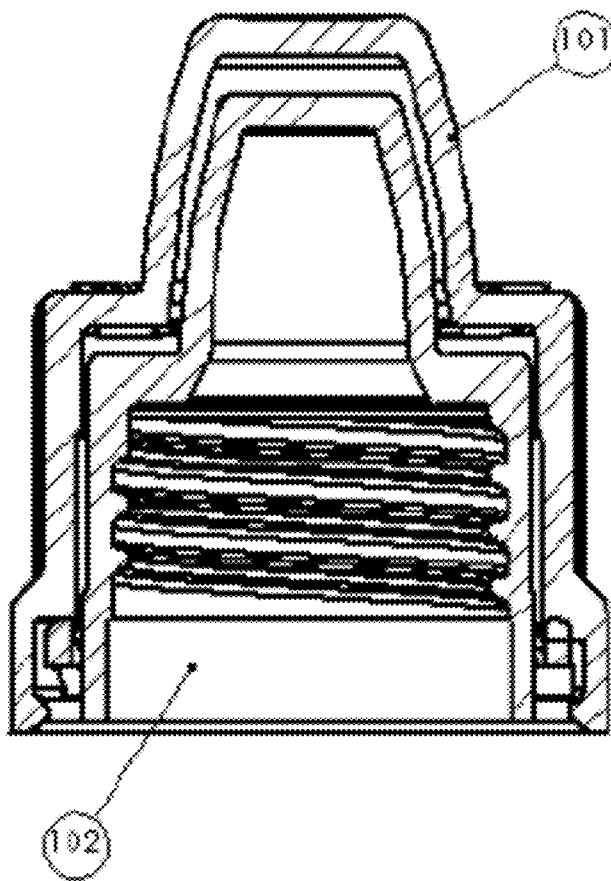

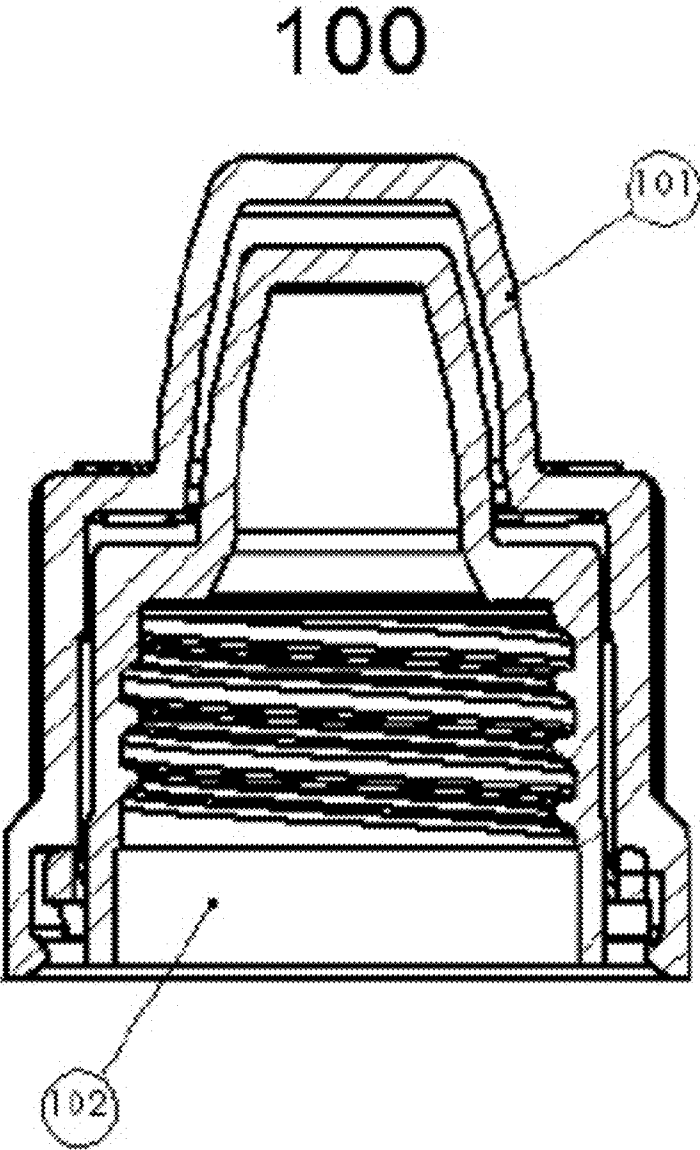
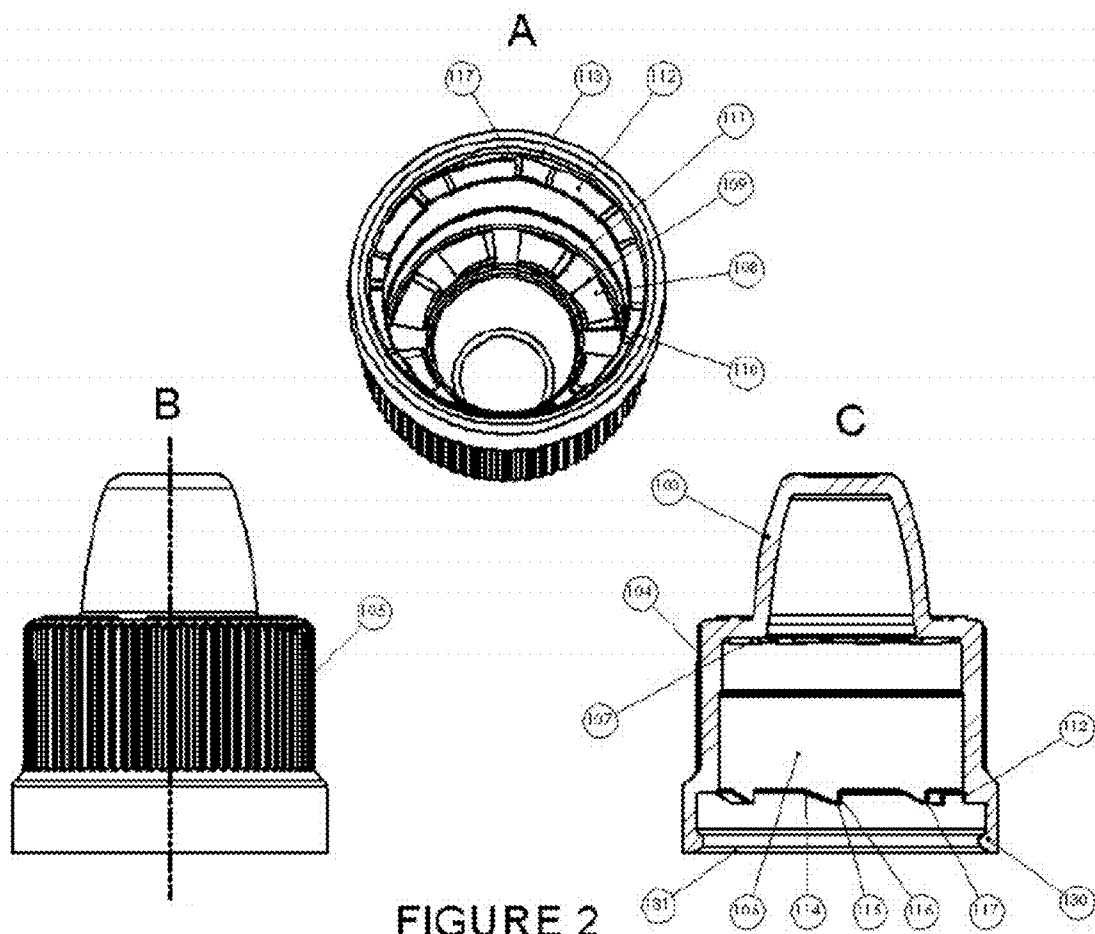

FIGURE 1



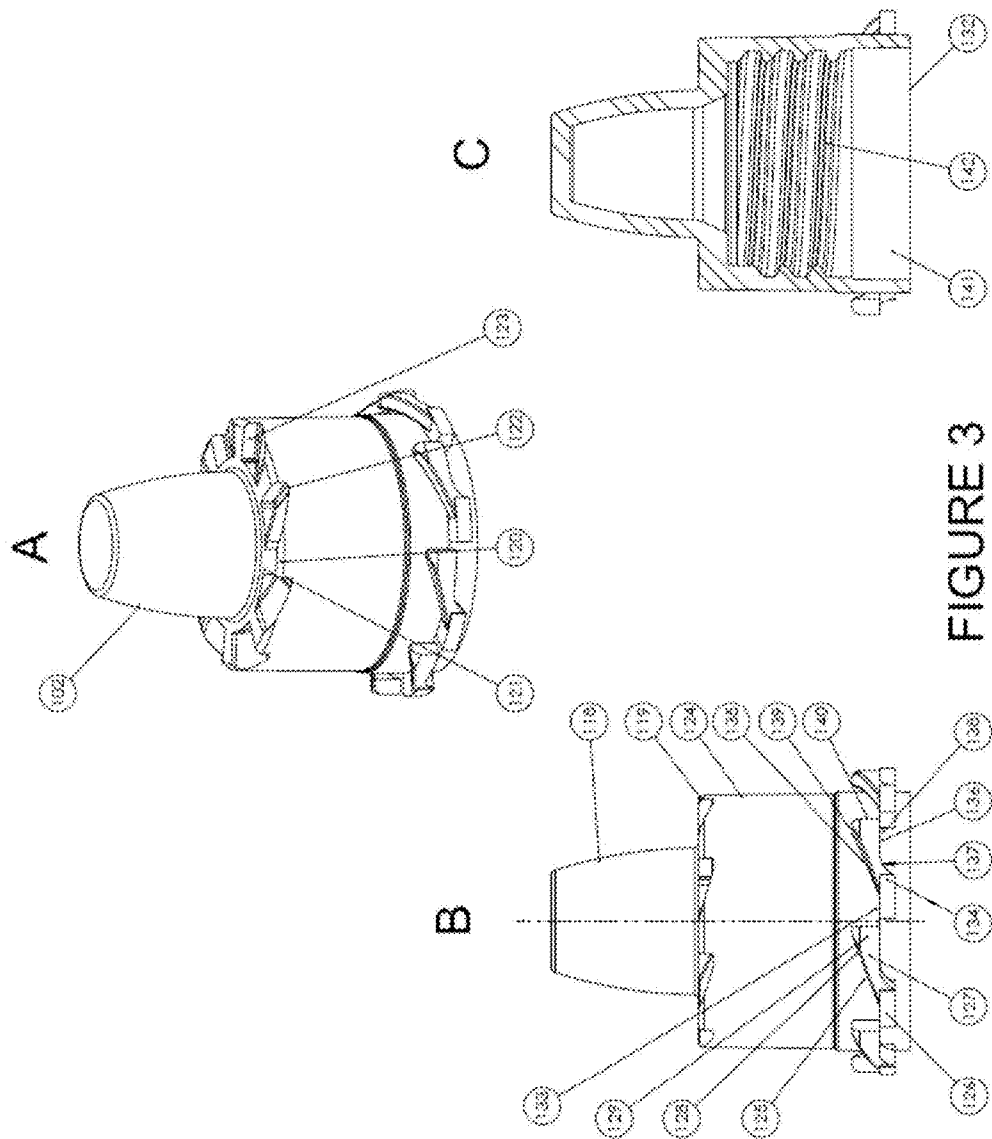

FIGURE 3

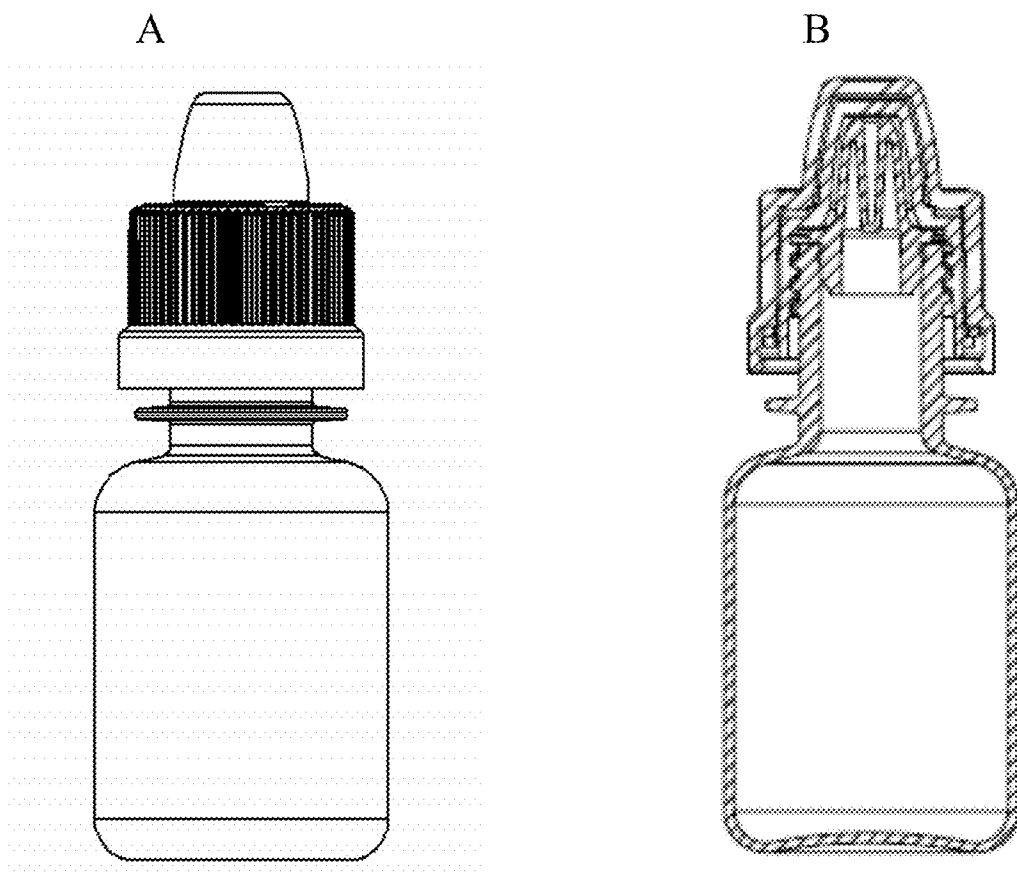

FIGURE 4

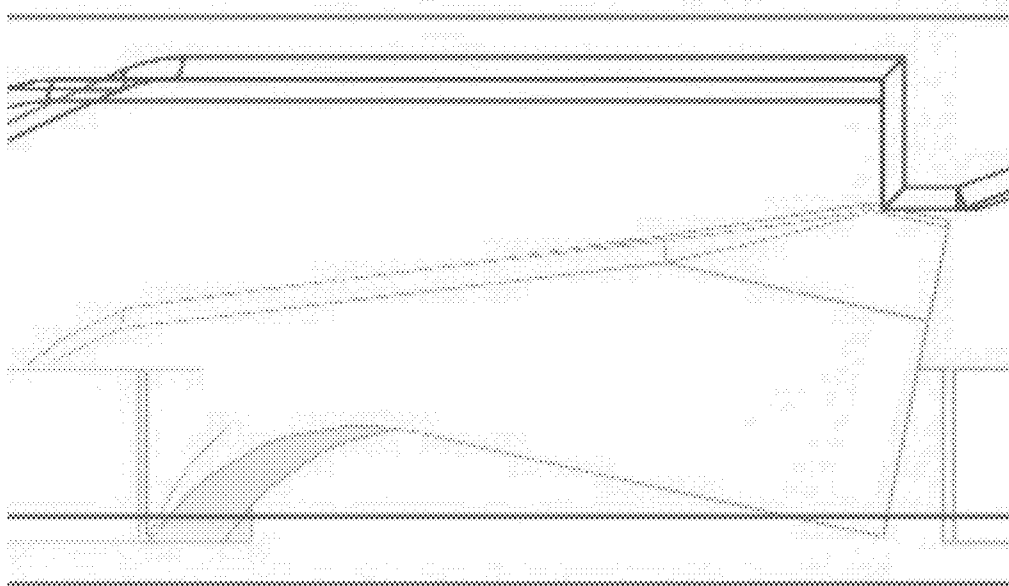
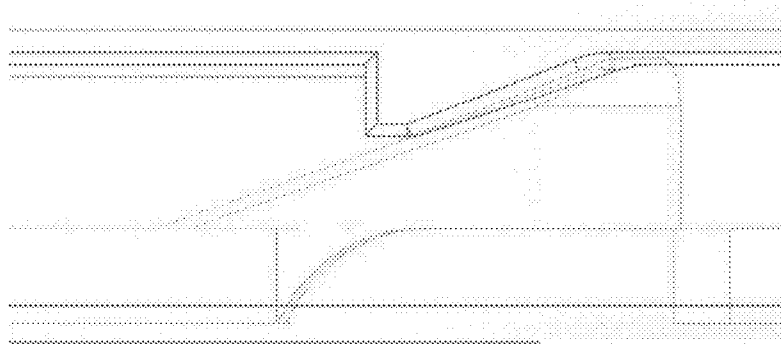
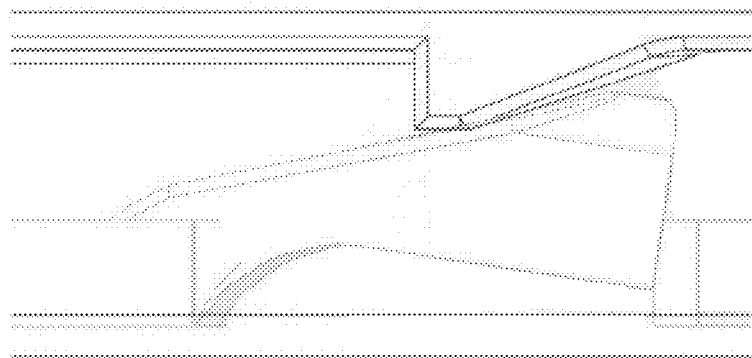

FIGURE 5

A



B



C

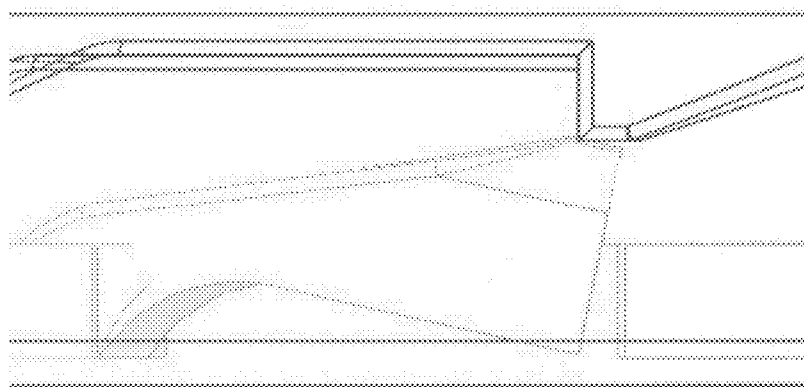

FIGURE 6

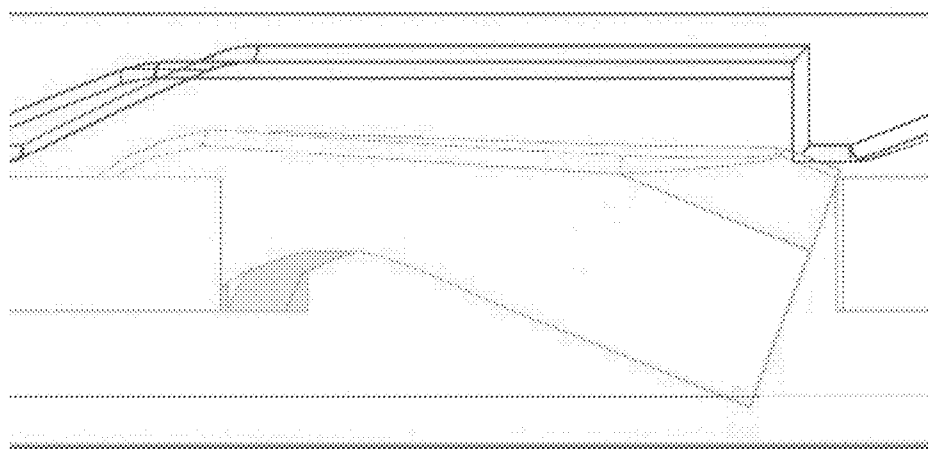

FIGURE 7

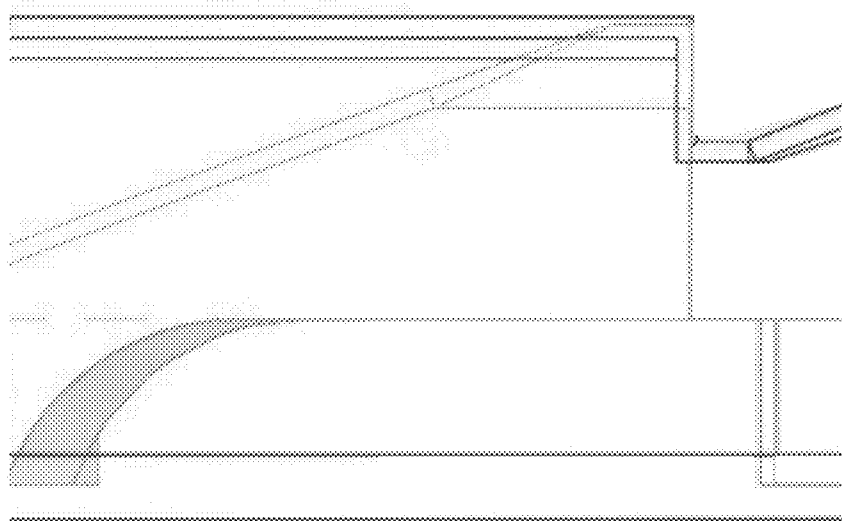

FIGURE 8

CHILD-RESISTANT CAP FOR LIQUID MEDICAMENTS

CROSS-REFERENCE TO RELATED APPLICATIONS

[0001] This application claims priority to U.S. Provisional Application 61/671,194 filed on Jul. 13, 2012, which is incorporated herein in its entirety.

FIELD OF THE INVENTION

[0002] The invention relates to improvements to child-resistant closures for dispensers of liquid medicaments, in particular dispensers of liquid ophthalmic and nasal medicaments, and thereby provides enhanced safety of the dispensers by making the contents of the containers less susceptible to access by children.

BACKGROUND OF THE INVENTION

[0003] Child-resistant caps for medicaments have been known in the art for nearly fifty years. These caps generally require two opposed movements acting at the same time to overcome the locking mechanism. For example, one type of cap requires a user to squeeze the cap at specific points, causing a deformation, and then to rotate the cap. If either the squeezing or rotating step is not performed, the cap cannot be opened. Another common method for imparting child-resistance on a cap is to require that the cap be pushed in a downward direction and then turned in order to be removed. Again, it can be seen that the two movements are opposed to one another; it is only through application of this unnatural combination of movements that the cap can be removed. Such a cap is disclosed in U.S. Pat. No. 5,316,161.

[0004] However, several issues arose with implementation of prior art caps. Such caps utilized unequal numbers of lugs and their mates; that is to say, in a two-piece closure, the prior art taught a greater number of lugs, beams, or fingers on an inner shell than the corresponding number of lugs, beams, or fingers on an outer shell or vice-versa. This meant that not all of the lugs, beams, or fingers of one shell were being engaged. This lack of engagement allowed for slippage during the rotational process, which can lead to damage to the lugs, beams, and fingers of both the outer and inner caps. Such damage often manifested itself in the form of stripping of the lugs, beams, and fingers. When these parts become stripped, the user is required to apply greater downward force to engage the appropriate mechanisms. However, the application of this downward force would often result in additional damage to the lugs, beams, or fingers. Additionally, prior art caps utilized flexible lugs, beams, or fingers with an angled underside. This angled underside presented problems in that it would concentrate flexion at a very specific point which would often weaken the lug, beam, or finger.

[0005] When excess force is applied to flexible lugs, beams, or fingers, they are often forced to flex beyond their capabilities. This hyper-flexion can result in a permanent deformation and even complete breakage of the lugs, beams, or fingers. In lugs, beams, or fingers having an angled underside, breakage often occurred immediately above the angle. Once breakage has occurred, whether above the angle or elsewhere, the deformed or broken lugs, beams, or fingers may no longer exert a contrary or biasing force on other component parts of the cap. In such situations, no downward force is necessary

for removal, leaving only a rotational force required to remove the cap. Therefore, the cap is no longer child-resistant.

[0006] Additionally, prior art caps often permitted an outer cap to float above and rotate unhindered about an inner cap until the application of a downward force. However, a major complaint of child-resistant caps has been that they are difficult for the elderly and infirm to remove. With free-floating caps, the elderly often have a difficult time applying the appropriate amount of downward force necessary to get the appropriate lugs, beams, or fingers to engage. Similarly, the elderly often have a difficult time maintaining the appropriate downward force throughout the rotational movement. When applied to prior art caps, this lack of coordination and partial engagement would result in frustration on the part of the user. Redoubled efforts often resulted in damage to the elements of the cap, through the combination of improper alignment and application of excess force, albeit briefly applied. This was manifested in the crushing of certain portions or the stripping of others. Additionally, when excess force is applied to a misaligned cap, portions of the cap may jam, requiring additional unconventional movements to clear the jam. These unconventional movements may damage the cap, again leading to decreased, if not eliminated, child-resistance.

[0007] Similarly, an additional problem of prior art caps is that they require a downward force to apply them to a pre-existing bottle. This is especially important to manufacturers, as machines capable of applying a downward force are more expensive than those which only apply a rotational force. Work-arounds have been designed, however they are expensive and can often involve re-tooling of a machine, at a cost which eats into the profit margin of the manufacturer. Additionally, on machines imparting a downward force (whether through original design or through later modifications), the amount and timing of downward force must be carefully calculated and must remain within specific tolerances. If the machine ventures too far beyond these tolerances, excess downward force may be applied to the cap as it is being affixed to the pre-existing bottle, and damage to the lugs, beams, and fingers may result. As mentioned above, such damage includes, but is not limited to, deformation or breakage of the lugs, beams, or fingers, as well as crushing of other various critical components of the cap.

[0008] Finally, when prior art child-resistant closure mechanisms were applied to dispensers of liquid medicaments, their design did not significantly differ from bottles for pill-form medicaments. That is to say, the shape of the cap was cylindrical, which created a large interior cavity where medicament could pool when the bottle was inverted while the cap was affixed thereto. In such prior art caps, a large quantity of residual medicament would then remain in the cap upon removal. Should a young child obtain access to this medicament-laden cap, it would be possible for the child to ingest significant quantities of the liquid medicament simply by removing the residual amount stored in the inner chamber of the cap.

[0009] As a result, in light of the foregoing, it is clear that there is an unmet need in the art. The prior art caps are prone to damage resulting in loss of child-resistant qualities, and further, may unintentionally provide access to significant amounts of residual liquid medicament stored in the removed cap. Specifically, there has been a need for a cap: (1) which reduces potential for damage to component parts through full engagement of lugs, beams, or fingers, (2) prevents over-

flexion of lugs, beams, or fingers, (3) modifies the shape of lugs, beams, or fingers, (4) allows the elderly to more easily remove the cap, (5) provides for easier application of the cap by manufacturing processes while at the same time reducing the likelihood of damage to the cap, and (6) minimizes the amount of residual medicament accessible to a child in possession of the removed cap.

BRIEF SUMMARY OF THE INVENTION

[0010] The present invention provides an improved child-resistant closure for liquid ophthalmic and nasal medicaments, as well as a system for providing child-resistant closure of an existing bottle, and a method of application and removal, providing ease of application during the bottling phase and enhanced child-resistant properties once the apparatus and system have been distributed to an end user.

[0011] One embodiment of the closure provides for a cap with matching numbers of complementary lugs and beams, with the flexible beams having an angled ridge with an arcuate underside. Additional embodiments of the closure include the requirement that an underside of an upper lug overlap a lower flexible beam by a predetermined distance or range of distances when the lug faces of upper lugs are properly aligned. These embodiments improve upon the reliability of a child-resistant closure by ensuring that it is only engaged when properly aligned, providing ideal frictional contact, and preventing undue stress upon the flexible beams when a downward force has been applied to them. Additional embodiments include modifications to a top portion of the cap, wherein one embodiment provides for a flat top and an alternative embodiment provides for a shaped top, complementary to the shape of a dispenser of liquid medicaments, to minimize the internal volume available for unintentional pooling of excess medicament.

[0012] An additional embodiment of the invention is a system in which flexion of the flexible beams is limited such that the beam head does not extend below the beam base of an adjacent flexible beam. By limiting such flexion, the beams are not damaged by hyper-flexion. The prior art does not address this issue, and by permitting beams to be unnecessarily hyper-flexed, the resiliency of the beam is decreased, often to the point where no downward force is necessary to engage the lugs of the cap, and the child-resistant nature of the cap has been eliminated.

[0013] The final embodiments of the invention relate to methods for attaching and removing the closure from a bottle containing liquid medicaments. In one embodiment, the steps of applying a downward force and rotating the outer cap are sequential. In another embodiment, the steps are simultaneous. However, the present invention advantageously eliminates the requirement of a constant downward force, such elimination being beneficial for elderly populations or those with arthritis. The final embodiment of the invention relates to the manner in which the invention is affixed to a bottle containing liquid medicaments. In this embodiment, no downward force is necessary. As a result, the present method is advantageous in that it does not require a re-tooling of present cap-applying machinery which lack the ability to exert a downward force. By providing for a method in which no downward force is needed, not only are more machines capable of affixing the cap to the bottle, but there is also a reduction in the likelihood of damage to the flexible beams due to miscalibrations in the amount of downward force required.

[0014] Additional objects, advantages and novel features of the invention will be set forth in part in the description, examples and figures which follow, all of which are intended to be for illustrative purposes only, and not intended in any way to limit the invention, and in part will become apparent to those skilled in the art on examination of the following, or may be learned by practice of the invention.

BRIEF DESCRIPTION OF THE FIGURES

[0015] The foregoing summary, as well as the following detailed description of the invention, will be better understood when read in conjunction with the appended drawings. It should be understood, however, that the invention is not limited to the precise arrangements and instrumentalities shown.

[0016] FIG. 1 shows the improved child-resistant cap.

[0017] FIGS. 2A-2C show multiple views of the outer cap.

[0018] FIGS. 3A-3C show multiple views of the inner cap.

[0019] FIGS. 4A-4B show a cap with top sections complementary to the shape of a dispenser nozzle for liquid medicaments affixed to a pre-existing bottle.

[0020] FIG. 5 shows the overlap of the skirt lug with the flexible beams when lug faces of the shoulder lugs are aligned.

[0021] FIGS. 6A-6C shows the movements of the skirt lugs of the outer cap and the flexible beam of the inner cap as the outer cap is rotated counter-clockwise relative to the inner cap.

[0022] FIG. 7 shows the flexible beam when the lug faces of the shoulder lugs of the inner and outer caps have been aligned and a downward force has been applied to the outer cap.

[0023] FIG. 8 shows engagement of the flexible beam and the skirt lugs required to thread the cap onto a bottle.

DETAILED DESCRIPTION OF EXEMPLARY EMBODIMENTS OF THE INVENTION

[0024] For the purposes of the present disclosure, the term “overlap” shall be understood to mean the horizontal distance measured from the vertical plane of a lug face of a skirt lug to the vertical plane of the nearest beam face of a flexible beam, when the lug faces of shoulder lugs on inner and outer caps are aligned.

[0025] For the purposes of the present disclosure, the term “lug” shall be understood to include both male lugs and female lugs. Thus, discussion of “lugs” engaging one another shall be understood to include complementary male and female lugs engaging one another, two or more male lugs engaging one another, as well as two or more female lugs engaging one another. Similarly, discussions of flexible beams engaging lugs shall be understood to include engagement of male or female lugs by a flexible beam.

[0026] For the purposes of the present disclosure, the term “depth,” when referring to lugs, shall be understood to be a measure of the change in vertical length between a first end and a second of a lug. As such, with regard to a female lug, the term “depth” shall be understood to be a measure of the trough created by second end of the lug. Similarly, with regard to a male lug, the term “depth” shall be understood to be a measure of the peak created by the second end of the lug. The term “depth” has been selected because in the embodiments shown, shoulder lugs of the outer cap are male and extend in a downward direction, where they mate with female

shoulder lugs of the inner cap. However, the term “depth” is not limited to such male-to-female engagements nor to the relative directions depicted in the figures.

[0027] The present invention may be constructed of any one of a number of polyolefins, including but not limited to polypropylene, as well as high-, medium-, and low-density polyethylene. These materials are known for their critical mechanical properties including, but not limited to, their flexural modulus, tensile strength, and elongation, and with the benefit of the present disclosure, one of ordinary skill in the art would understand that other materials exhibiting the same properties could be used in the construction of the cap, and therefore the invention is not limited to embodiments constructed of the materials listed above, but is intended to include all materials, whether presently known or developed in the future, which may exhibit similar structural properties.

[0028] Turning now to FIG. 1, it can be seen that the child-resistant cap 100 is of a two-part construction, with an outer cap 101 and an inner cap 102. As can be seen in FIG. 2C, outer cap 101 has a top portion 103 which is adjacent to depending skirt 104. As shown in FIG. 2B, in one embodiment, depending skirt 104 contains a gripping surface 105, which may be defined by ridges, dimples, cross-hatching, or any other mechanism or method known to one skilled in the art to increase the friction between the hand of a user and outer cap 104. However, although the embodiment depicted in FIG. 2B includes gripping surface 105 embodied in the form of ridges, the invention is not so limited, and it is contemplated that in alternative embodiments, the materials used in the construction of outer cap 101 will provide adequate friction and gripping capabilities for a user, and thus no independent gripping surface 105 may be present.

[0029] Turning to FIGS. 2A and 2C, outer cap 101 also has an internal chamber 106 defined by the interior surfaces of top portion 103 and depending skirt 104. The shape of internal chamber 106 includes shoulder 107, on which is mounted a quantity of shoulder lugs 108. Shoulder lugs 108 have a first end 109 and a second end 110. The depth of shoulder lugs 108 increases from first end 109 to second end 110. The depth of shoulder lugs 108 may be varied to suit the specific needs of the enclosure, and with the benefit of the present disclosure, one skilled in the art would be enabled to tailor the depth of shoulder lugs appropriately. In one embodiment, the depth of shoulder lugs 108 ranges from between 0.015 to 0.040 inches, although the present invention is not limited to this embodiment. Second end 110 has a lug face 111, oriented perpendicular to the longitude of shoulder lug 108 and distal to first end 109. Further, the orientation of each lug face 111 is common, providing for a common rotational direction. That is to say, when each lug face 111 is acted upon by another object, the direction of action provides for a consistent rotational action around a central axis. In an alternative embodiment, second end 110 also includes a bottom surface extending parallel to the longitude of shoulder lug 108 and providing for a ninety-degree or “right angle” transition from second end 110 to lug face 111.

[0030] Internal chamber 106 is further defined by an annular ridge 112 located at a predetermined distance from shoulder 107. The distance between shoulder 107 and annular ridge 112 is greater than the height of shoulder lugs 108, and with the benefit of the present disclosure, one skilled in the art would be enabled to tailor the distance between shoulder 107 and annular ridge 112 as required for the size and shape of the bottle and closure in question. In one embodiment, this may

range from 0.562 to 0.576 inches, although the present invention is not limited to this embodiment.

[0031] Annular ridge 112 contains a quantity of skirt lugs 113. As with shoulder lugs 108, skirt lugs 113 have a first end 114 and a second end 115, with second end 115 having a lug face 116. Lug faces 116 are oriented perpendicular to the longitude of skirt lug 113 and distal to first end 114. Further the orientation of each lug face 116 is common, such that when each lug face 116 is acted upon by another object, a common rotational direction is achieved, providing for rotation about a central axis. However, the orientations of lug faces 116 is opposite that of the orientations of lug faces 111. That is to say, if a clockwise application of force is required to act upon and engage lug faces 111, the opposite, counter-clockwise application of force is required to act upon and engage lug faces 116, and vice versa. Second end 115 also has bottom surface 117, oriented distal to top portion 103.

[0032] Outer cap 101 also includes an assembly retaining bead 130 located within internal chamber 106 at a location distal to both shoulder 107 and annular ridge 112. In one embodiment, assembly retaining bead 130 is located a distance inward from open end 131 of outer cap 101. In an alternative embodiment, assembly retaining bead 130 is located at open end 131.

[0033] Outer cap 101 is capable of vertical movement relative to inner cap 102. In one embodiment depicted by the figures, the vertical downward travel distance of outer cap 101 relative to inner cap 102 is 0.067 inches, although the present invention is not so limited. Indeed, with the benefit of this disclosure, one skilled in the art would be enabled to determine the appropriate downward travel for bottles of varying sizes, as may be required by product specifications set forth by the manufacturer.

[0034] As shown in FIGS. 3A-3C, inner cap 102 has a top portion 118, a shoulder 119, a depending skirt 124, and an open end 132. As can be seen in FIG. 3B, Shoulder 119 is located at the transition point between top portion 118 and depending skirt 124. FIG. 3A depicts a quantity of shoulder lugs 120 mounted on shoulder 119. Shoulder lugs 120 have a first end 121 and a second end 122. Second end 122 has a lug face 123 located distal to first end 121 and oriented perpendicular to the longitude of shoulder lugs 120. The orientation of lug faces 123 is common, such that when each lug is acted upon by another object, common rotational direction is achieved, providing for rotation about a central axis. The orientation of lug faces 111 is complementary to the orientation of lug faces 123 to provide for engagement of one lug face by the opposing lug face. In one embodiment, the depth of shoulder lugs 120 ranges from between 0.015 to 0.040 inches, although the present invention is not limited to this embodiment.

[0035] Turning to FIG. 3B, depending skirt 124 has a quantity of flexible beams 125 mounted thereon. Flexible beams 125 extend around portions of the perimeter of depending skirt 124. Each flexible beam 125 consists of a beam base 126 and a beam arm 127. Beam arm 127 has an angled ridge 128 which terminates in a beam head 129. Beam base 126 has an upper face 133 and a leading face 134. Angled ridge 128 has a top side 135 and an underside 136. Angled ridge 128 is connected to beam base 126 such that top side 135 extends from upper face 133 and underside 136 extends from leading face 134. Underside 136 extends from leading face 134 in an arcuate or radiused manner. When downward force is exerted upon flexible beam 125, flexion or deformation takes place

along angled ridge **128**. The construction of flexible beam **125** is such that it has a resiliency which permits for it to return to its original shape and location when the downward force is no longer applied. In one embodiment, as pictured in FIGS. 3A-3C, underside **136** consists of an arcuate or radiused portion **137** adjacent to a straight portion **138**. In an alternative embodiment not shown, underside **136** consists entirely of an arcuate or radiused portion **137**. Beam head **129** has an upper surface **139** and a beam face **140**. In one embodiment, the radius of arcuate or radiused portion **137** is 0.065 inches, although the invention is not so limited. With the benefit of the present specification, one skilled in the art would understand that any radius up to and including a radius of 0.095 inches could be utilized. Indeed, as the materials used in the construction of flexible beam **125** vary, different radii may be necessary to provide for maximum resiliency of flexible beam **125** while at the same time ensuring that downward forces exerted upon flexible beam **125** do not result in the deformation of flexible beam **125** in a vector oriented radially to a central axis.

[0036] Beam faces **140** are located distal to beam base **126** and have an orientation permitting for a common rotational direction about a central axis, such that force imparted on any beam face **140** will result in inner cap **102** rotating in the same direction about a central axis. The orientation of beam faces **140** is complementary to the orientation of lug face **116**, and correspondingly the common rotational direction of beam faces **140** is complementary to the common rotational direction of lug faces **116**.

[0037] The quantity of shoulder lugs **108** must be equivalent to the quantity of shoulder lugs **120**. Additionally, the quantity of skirt lugs **113** must be equivalent to the quantity of flexible beams **125**. Equivalent quantities provide for maximum engagement of lugs and complementary lugs and/or beams. Additionally, equivalent quantities of shoulder lugs **108**, shoulder lugs **120**, skirt lugs **113**, and flexible beams **125** provide for maximal engagement of outer cap **101** with inner cap **102**. As such, in one embodiment, the quantity of shoulder lugs **108** is equal to the quantity of shoulder lugs **120** and the quantity of skirt lugs **113** is equal to the quantity of flexible beams **125**. In an alternative embodiment, the quantities of shoulder lugs **108**, shoulder lugs **120**, skirt lugs **113**, and flexible beams **125** are all equal. Traditional closure mechanisms have permitted unequal numbers of complementary lugs and or beams; such as six lugs designed to be complementary mates to eight fingers. These unequal quantities result in an increased chance of slippage between beams and lugs, and such slippage can result in damage to the flexible beams themselves, including permanent upward or downward deformation of the beams or crushing of the lugs, leading to a decrease in, or even full elimination of, the child-resistant nature of the two-part closure.

[0038] As can be seen in FIG. 3C, inner cap also has an internal cavity **141** defined by the internal surfaces of top portion **118**, shoulder **119**, and depending skirt **124**. The internal surface of depending skirt **124** is configured with threads **142** to permit attachment of the cap to a pre-existing bottle with complementary, mated threads on its neck face.

[0039] In one embodiment, top portions **103** and **118**, are flat and do not extend above shoulder **107** and **119** respectively.

[0040] FIGS. 4A-4B depict cap **100** when it is attached to a pre-existing bottle. FIG. 4A shows the outer view of cap **100** when it is attached to a pre-existing bottle. FIG. 4B shows a

cross-sectional view of cap **100** attached to a bottle, with top portions **103** and **118** extending above and away from shoulder **107** and shoulder **119** respectively. In the depicted embodiment, top portions **103** and **118** have a shape which is complementary to the shape of a dispenser nozzle for liquid medicaments. This complementary shape provides for an extra level of safety with regard to access of the medicament by a child. In embodiments with flat top portions **103** and **118**, when cap **100** is affixed to a bottle of liquid medicaments and the bottle is inverted, there is the potential for liquid to flow out of the bottle and pool within the area created by the internal cavity of inner cap **102**. Embodiments containing such an extruded shape complementary to the shape of a nozzle of a dispenser of liquid medicaments significantly reduce the overall volume of the cap cavity by more closely approximating the size and shape of the dispenser nozzle. By providing for a smaller cavity where medicaments may inadvertently pool, the embodiment depicted in the Figures reduces the likelihood of accidental overdose by children who ingest residual medicament from a cap which has been removed from the dispenser.

[0041] Another feature of the present invention involves the spatial relationship of shoulder lugs **108** and **120** as they relate to skirt lugs **113** and flexible beams **125**. FIG. 5 demonstrates the overlap exhibited by skirt lugs **113** and flexible beam **125** when lug faces **111** and **123** are aligned. In one embodiment, the overlap is a predetermined horizontal distance of 0.019 inches, although the present invention is not so limited, and alternative embodiments include overlaps in a variety of ranges. For example, in an alternative embodiment, the range for predetermined horizontal distances of overlap is between 0.016 and 0.022 inches. In yet another alternative embodiment, the range for overlap distance as between 0.013 and 0.025 inches. With the benefit of the present disclosure, one skilled in the art would be enabled to create a closure with an overlap appropriate to any size of cap as may be required by production specifications.

[0042] An additional benefit of the present invention relates to the interaction between shoulder lugs **108**, flexible beams **125**, and assembly retaining bead **130**. As discussed above, flexible beams **125** have a resiliency which allow them to be deformed when a downward force is applied and then return to their original shape and location when the downward force is removed. This resiliency provides an upwards biasing force on shoulder lugs **108**. This upward biasing force is counteracted by assembly retaining bead **130**, in that assembly retaining bead **130** prevents the upward biasing force exerted on shoulder lugs **108** by flexible beams **125** from detaching outer cap **101** from inner cap **102** entirely. As seen in FIGS. 6A-6C, when outer cap **101** is rotated relative to inner cap **103** in the direction required for removal of cap **100** from a bottle, most commonly in the counter-clockwise direction, skirt lugs **113** will come in contact with flexible beam **125**. FIG. 6A shows skirt lug **113** first coming into contact with flexible beam **125**. FIG. 6B demonstrates the result when the rotational direction of outer cap **101** continues with skirt lugs **113** riding along angled ridge **128**. If no downward force is applied to outer cap **101**, the incline of angled ridge **128** will cause outer cap **101** to rise vertically with respect to inner cap **102** until assembly retaining bead **130** engages inner cap **102**, thus preventing any further vertical movement of outer cap **101** relative to inner cap **102**. When assembly retaining bead **130** has engaged inner cap **102**, despite the vertical movement of outer cap **101** relative to inner cap **102**, bottom surface **117** of skirt

lug 113 remains in contact with beam head 129 of flexible beam 125. As such, at not time does bottom surface 117 extend above beam head 129 in such a manner as to provide unencumbered rotation of outer cap 101. Instead, even when the vertical distance between outer cap 101 and inner cap 102 is at its greatest, there is still a frictional force between bottom surface 117 and beam head 129. As a result, outer cap 101 rises and falls vertically with respect to inner cap 102, in a ratcheting motion when it is rotated in this manner.

[0043] As has been described above, if no downward force is exerted upon outer cap 101, it will rise vertically with respect to inner cap 102 when rotated in the direction of removal. This is shown in FIG. 6C. Additionally, if no downward force has been exerted upon outer cap 101, when it has been rotated to align lug face 111 with lug face 123 of inner cap, outer cap 101 will be at its furthest possible vertical distance from inner cap 101, although, as has been described, the two caps remain in contact with one another due to the effects of assembly retaining bead 130 engage inner cap 102. However, when in this aligned position, lug face 111 has not yet engaged lug face 123, due to the vertical differential between the two caps. When a downward force is applied to outer cap 101 as shown in FIG. 7, this vertical differential is decreased, and lug face 111 may finally engage lug face 123. This downward force deforms or flexes each flexible beam 125, however this downward force is halted when shoulder lug 108 is fully nested in and engaged with shoulder lug 120. Further, this downward force acts upon beam head 129 and causes it to change position. However, the relationship of the depth of the shoulder lugs and the displacement of the beam head is such that when shoulder lugs 108 have fully engaged and nested in shoulder lug 120, that is to say, when it is no longer possible for outer cap 101 to move any further downward relative to inner cap 101, beam head 129 is at its lowest position. This position is the optimal deformation of flexible beam 125, does not travel below the bottom of the adjacent beam base 126. Further, this downward force deforms or flexes angled ridge 128 such that angled ridge becomes approximately parallel with the adjacent beam base 126 when beam head 129 is at its lowest position. By limiting the distance which beam head 129 travels, hyper-flexion of flexible beam 125 can be prevented. This is advantageous, because hyper-flexion can result in a loss of resilience of flexible beam 125. When resilience is lost, an active downward force is no longer required to engage lug face 111 of shoulder lug 108 with lug face 123 of shoulder lug 120. When the downward force is no longer required, the cap has lost its child-resistant nature. Therefore, the design of the present invention represents an improvement upon prior art, in that it eliminates hyper-flexion, and thus preserves the child-resistant nature of the cap; while the prior art, lacking such a defined spatial limitation on flexion, permits hyper-flexion and its resultant damage to flexible beam 125 and loss of child-resistant functionality.

Method of Use

[0044] The closure described above is designed to be applied to pre-existing bottles for liquid medicaments. It is understood that these bottles will already have threads provided on their neck finishes.

[0045] Application of the cap to the pre-existing bottle is effected thusly: a rotational movement is applied to outer cap 101 in an attaching direction about a central axis and relative to inner cap 102, the direction most commonly being clock-

wise, until lug face 116 engages beam face 129, as shown in FIG. 8. Once lug face 116 has engaged beam face 140, the rotational movement is maintained on outer cap 101. This force is then transferred to inner cap 102, permitting the two caps to rotate in concert about a central shared axis. This rotation of inner cap 102 allows threads 142 to engage the threads of the pre-existing bottle. Rotation is maintained until threads 142 have fully engaged the threads of the pre-existing bottle. At this point, rotation ceases, and cap 100 has been affixed to the pre-existing bottle. As a result, no additional downward force is required to apply cap 100 to the pre-existing bottle. The engagement of threads 142 with the threads of the pre-existing bottle will impart a downward force on the cap 100 and cause it to travel downwards relative to the pre-existing bottle. However, this downward force is the mechanical result of the engagement of threads 142 and is not imparted directly by the user. This represents a benefit over the prior art in that present machinery which is only capable of imparting a rotational direction may be used to affix cap 100 to a bottle—there is no re-tooling of the machine necessary. Additionally, machines imparting a downward force require careful calibration which can often be thrown out of alignment over the course of time. In such cases, caps may be insufficiently applied to a bottle, or more importantly, may be over tightened, causing damage to flexible beam 125, more specifically beam head 129. Prior art methods of affixing a child-resistant to a cap containing flexible beams 125 have often required a downward force, which could potentially crush beam head 129 or result in an increase in the depth of shoulder lugs 108 and 120. Crushed beam heads 129 prevent the proper upward biasing of outer cap 101.

[0046] Removal of the cap is effected thusly: a downward force is applied upon outer cap 101, moving it in a downward direction relative to inner cap 102. A rotational movement is then applied to outer cap 101 in a removal direction about a central axis relative to inner cap 102, the direction most commonly being counter-clockwise. Rotation of outer cap 101 is continued until shoulder lugs 108 engage shoulder lugs 120. Rotation of outer cap 101 continues, and the rotational force is transferred to inner cap 101 due to the engagement of shoulder lugs 108 with shoulder lugs 120. This continued rotation permits outer cap 101 and inner cap 102 to rotate in concert about a central axis. This rotation of inner cap 102 begins to disengage threads 142 from the threads of the pre-existing bottle. Once the initial torque needed to overcome the static frictional forces between threads 142 and the threads of the pre-existing bottle has been achieved, the user may optionally cease applying a downward force on outer cap 101. This option is available to the user because the flexible beam 125 will impart an upward biasing force on outer cap 101; at the same time, the placement of assembly retaining bead 130 will maintain contact between bottom surface 117 of skirt lugs 113 and the angled ridge 128 and beam head 129 of flexible beam 125. This contact results in friction which continues to transfer the rotational force imparted on outer cap 101 to inner cap 102. Thus, maintained rotation of outer cap 101 will result in concerted rotation of inner cap 102 despite the fact that shoulder lugs 108 may no longer be engaging shoulder lugs 120. The rotational force continues to be applied to outer cap 101 and transferred to inner cap 101 until threads 142 are fully disengaged from the threads of the pre-existing bottle. At this point the cap may be lifted from the pre-existing bottle. The method described above is particularly advantageous for the elderly, as it only requires the

downward force to be applied until the torque needed to overcome the static frictional forces between threads 142 and the threads of the bottle has been overcome; it requires the two-directional movement necessary to ensure child-resistance, but by permitting only single-directional movement at later stages of removal, ease of use is increased for those who have decreased coordination or strength due to advanced age and infirmity.

[0047] In an alternate embodiment, the first step of applying a downward force and the second step of applying a rotational force may be reversed, such that the rotational force is applied first and the downward force is applied second. In yet another alternative embodiment, the first two steps of applying a downward force and applying a rotational force are combined into a single step wherein the downward and rotational forces are applied simultaneously.

[0048] The disclosure of each patent, patent application and publication cited or described in this document is hereby incorporated herein by reference, in its entirety.

[0049] While the foregoing specification has been described with regard to certain preferred embodiments, and many details have been set forth for the purpose of illustration, it will be apparent to those skilled in the art without departing from the spirit and scope of the invention, that the invention may be subject to various modifications and additional embodiments, and that certain of the details described herein can be varied considerably without departing from the basic principles of the invention. Such modifications and additional embodiments are also intended to fall within the scope of the appended claims.

We claim:

1. A two-piece, child-resistant closure device for dispensers of liquid medicaments, the closure device comprising:

- an outer cap having
 - a top portion,
 - a depending skirt,
 - an internal chamber with
 - a shoulder having a quantity of shoulder lugs mounted thereon, each shoulder lug having
 - a first end, and
 - a second end, the second end comprising a lug face, wherein the lug faces are oriented in a common rotational direction, and
 - an annular ridge having a quantity of skirt lugs mounted thereon, each skirt lug having
 - a first end and
 - a second end, the second end comprising
 - a lug face and
 - a bottom surface
 - wherein the lug faces are oriented in a common rotational direction, and
 - wherein the rotational direction of the shoulder lug faces is opposite the rotational direction of the skirt lug faces, and
- an assembly retaining bead; and
- an inner cap having
 - a top portion,
 - a shoulder having a quantity of shoulder lugs mounted thereon,

- each shoulder lug having
 - a first end, and
 - a second end, the second end comprising a lug face, wherein the lug faces are oriented in a rotational direction complementary to the rotational direction of the lug faces of the shoulder lugs of the outer cap,
- a depending skirt having a quantity of flexible beams mounted thereon,
 - each flexible beam having
 - a beam base,
 - a beam arm comprising an angled ridge terminating in a beam head distal to the beam base, the angled ridge having an underside comprising a radius,
 - the beam head having an upper surface and a beam face,
 - wherein the beam faces are oriented in a common rotational direction complementary to the rotational direction of the lug faces of the skirt lugs of the outer cap
 - an inner threaded cavity;
 - wherein the quantity of shoulder lugs of the outer cap is equivalent to the quantity of shoulder lugs of the inner cap, and
 - wherein the quantity of skirt lugs of the outer cap is equivalent to the quantity of flexible beams of the inner cap.
- 2. The child-resistant closure device of claim 1, wherein when the lug faces of the shoulder lugs of the outer cap are aligned with the lug faces of the shoulder lugs of the inner cap, the skirt lug of the outer cap overlaps the flexible beam of the inner cap by a predetermined horizontal distance.
- 3. The child-resistant closure device of claim 2, wherein the predetermined horizontal distance is between 0.013 and 0.125 inches.
- 4. The child-resistant closure device of claim 3, wherein the predetermined horizontal distance is between 0.016 and 0.122 inches.
- 5. The child-resistant closure device of claim 4, wherein the predetermined distance is 0.019 inches.
- 6. The child-resistant closure device of claim 2, wherein the top portions of the inner and outer caps are flat and do not extend above the shoulders of the inner and outer caps respectively.
- 7. The child-resistant closure device of claim 2, wherein the top portions of the inner and outer caps have a shape which extends above the shoulders of the inner and outer caps respectively.
- 8. The child-resistant closure device of claim 7, wherein the shape of the top portions of the inner and outer cap is complementary to a shape of a dispenser nozzle for liquid medicaments.
- 9. A system for providing child-resistant closure of a bottle of liquid medicaments using the device of claim 1, wherein the flexible beam is capable of deformation.
- 10. The system of claim 9, wherein the flexible beam has an optimal deformation.
- 11. The system of claim 10, wherein upon optimal deformation of the flexible beam, the beam head is not oriented below the beam base of an adjacent flexible beam.
- 12. The system of claim 9, wherein the flexible beams exert an upward biasing force on the outer cap.
- 13. The system of claim 12, wherein the assembly retaining bead prevents the upward biasing force of the flexible beams from detaching the outer cap from the inner cap.

14. The system of claim **13**, wherein the assembly retaining bead is located on the outer cap at a distance from the bottom surface of the skirt lugs of the outer cap such that when the lug faces of the shoulder lugs of the upper cap are aligned with the lug faces of the shoulder lugs of the inner cap, the bottom surface of the skirt lugs of the outer cap remain in contact with the flexible beams of the inner cap.

15. A method for removing the child-resistant closure of claim **1** from an outwardly-threaded bottle of liquid medicaments, the method comprising:

applying a downward force on the outer cap,
applying a rotational movement upon the outer cap,
continuing to apply the downward force and rotational movement upon the outer cap until the shoulder lugs of the outer cap engage the shoulder lugs of the inner cap,
ceasing to apply a downward force to the outer cap,
maintaining the rotational movement applied to the upper cap such that the outer cap and inner cap rotate in concert about a central axis,

disengaging the closure from the outwardly threaded bottle of liquid medicaments.

16. The method of claim **15**, wherein the steps of applying a downward force on the upper cap and applying a rotational movement upon the upper cap are performed simultaneously.

17. A method for affixing the child-resistant closure of claim **1** to an outwardly-threaded bottle of liquid medicaments, the method comprising:

applying a rotational movement upon the outer cap until the skirt lugs of the outer cap engage the flexible beams of the inner cap,
maintaining the rotational movement applied to the outer cap such that the outer cap and inner cap rotation in concert about a central axis, and
allowing the concerted rotation of the outer and inner caps to engage a thread of an outwardly-threaded bottle, and
ceasing to apply rotation movement upon the outer cap once the inner cap has fully engaged the thread of the outwardly-threaded bottle.

* * * * *