

(No Model.)

2 Sheets—Sheet 1.

H. A. W. WOOD.  
PRINTING PRESS.

No. 569,310.

Patented Oct. 13, 1896.

Fig. 1.

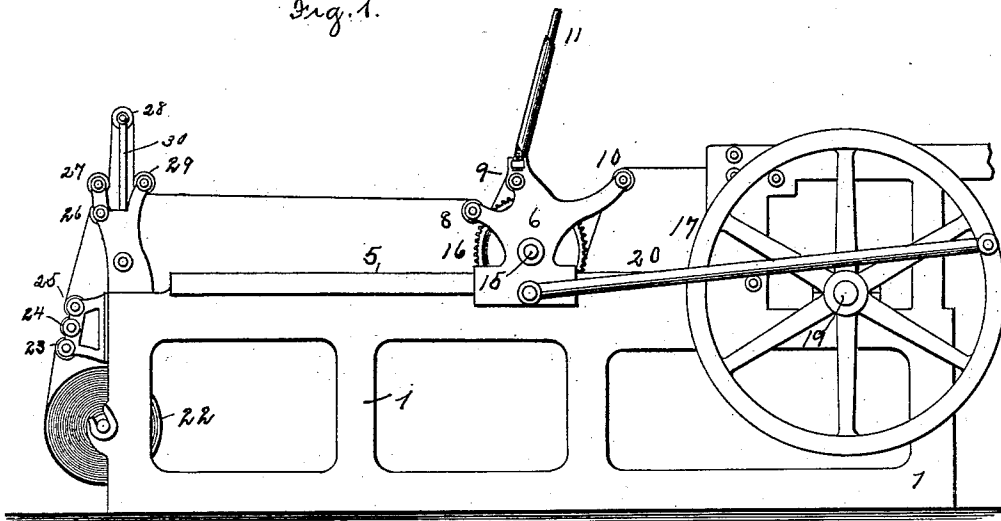
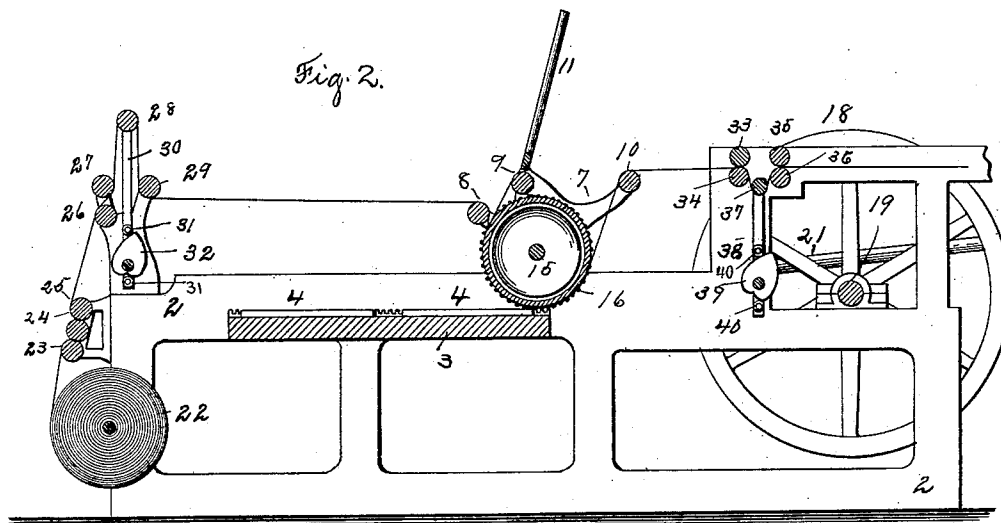

Fig. 2.



Witnesses  
*Chas. F. Johnson*  
*E. M. Healy*

Inventor  
 H. A. Wise Wood,  
 By his Attorney  
*Louis W. Southgate*

(No Model.)

2 Sheets—Sheet 2.

H. A. W. WOOD.  
PRINTING PRESS.

No. 569,310.

Patented Oct. 13, 1896.

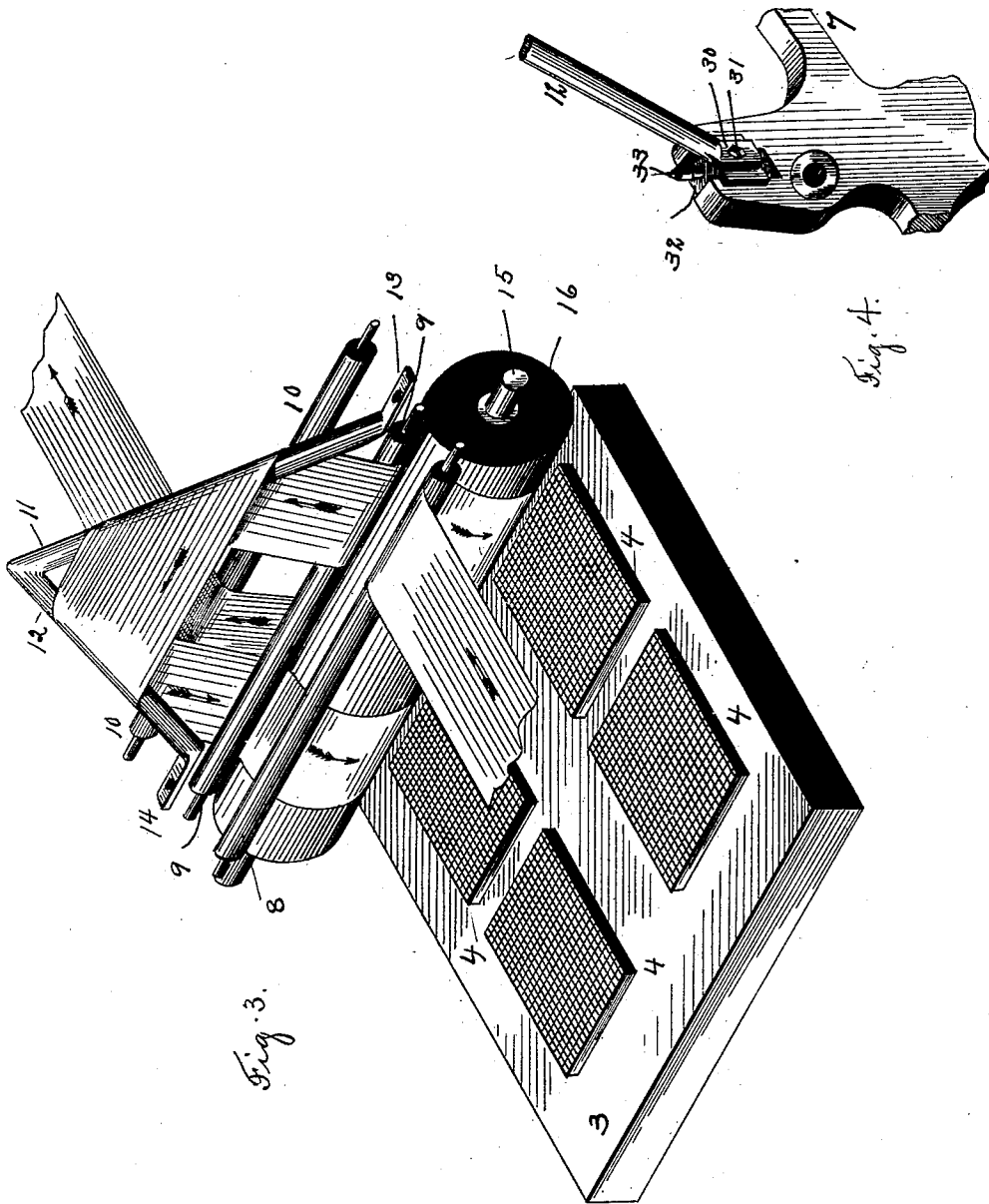

Fig. 3.

Fig. 4.

Witnesses  
*Chas. F. Schaefer*  
*E. M. Healy*

Inventor  
H. A. Wise Wood,  
By his Attorney  
*Louis W. Southgate*

# UNITED STATES PATENT OFFICE.

HENRY A. WISE WOOD, OF NEW YORK, N. Y., ASSIGNOR TO THE CAMPBELL PRINTING PRESS AND MANUFACTURING COMPANY, OF NEW YORK.

## PRINTING-PRESS.

SPECIFICATION forming part of Letters Patent No. 569,310, dated October 13, 1896.

Application filed July 14, 1892. Serial No. 439,964. (No model.)

*To all whom it may concern:*

Be it known that I, HENRY A. WISE WOOD, a citizen of the United States, residing at New York, in the county of New York and State of New York, have invented a new and useful Improvement in Printing-Presses, of which the following is a specification.

The aim of this invention is to produce a new and improved printing-machine especially adapted for printing upon a web; and the invention consists of the parts and combinations of parts described and claimed in this specification, and illustrated in the accompanying drawings, in which—

Figure 1 is a side elevation of a printing-machine embodying my improvements. Fig. 2 is a sectional elevation. Fig. 3 is a perspective view of the impression-cylinder and turner device, and Fig. 4 is a detailed view of the preferred way of mounting the turner device.

My invention relates to an improvement or modification of the machine described and claimed in patent to John H. Stonemetz, No. 376,053, dated January 3, 1888. In said Stonemetz patent are shown two stationary type or form beds arranged in the same plane with two cylinders, means for reciprocating said cylinders over the stationary form-beds, and feeding and guiding devices for leading a web around said impression-cylinders, so that as the same reciprocate they will perfect the web.

The aim of my invention is to accomplish the same result and dispense with one impression-cylinder and to shorten the path of the web. To this end I use an impression-cylinder substantially double the width of the web and arrange the forms on the bed side by side, and use in connection with the impression-cylinder a turner device that will direct the web twice around the impression-cylinder.

My invention is especially adapted in the particular device shown for perfecting the web, although by a slight change in the turner device the web could be twice printed on the same side.

Referring now to the drawings and in detail, 1 and 2 designate side frames, and between these side frames is arranged a suit-

able table or bed 3, upon which the forms 4 are placed.

I have shown in the drawings four forms, or two pairs arranged side by side, but it is evident that I may use only two forms arranged side by side and place the forms with either dimension parallel with the movement of the cylinder, or that I can use any other number of forms.

Arranged on the side frames are suitable guideways, as 5, and running on these guideways are the carriage-frames 6 and 7, and in these carriage-frames are mounted or arranged the guiding-rolls 8, 9, and 10 and the turner device 11, 12, 13, and 14.

The particular turner device illustrated consists of a bar of steel or wrought-iron which is bent to the shape shown, that is, to form two arms 11 and 12 substantially at right angles to each other, and to form two feet 13 and 14, whereby the device may be attached or secured in the carriage-frames. Also mounted in the carriage-frames 6 and 7 is a shaft 15, on which is arranged the impression-cylinder 16, and attached to the sides of the impression-cylinder 16 are gears which mesh in racks on the sides of the bed, as shown, and as described at length in the Stonemetz patent referred to, whereby the cylinder will be always kept in register with the bed.

In the particular device under consideration all the inking apparatus and gearing is omitted, as the same is well understood in this particular art and forms no especial part of my invention.

The carriage-frames are reciprocated back and forth by means of two fly-wheels or gears 17 and 18, mounted on shaft 19, journaled in the side frames, which fly-wheels are connected to the carriage-frames 6 and 7 by connecting-rods 20 and 21. The shaft 19 is driven in any of the usual manners whereby the impression-cylinder will be reciprocated back and forth over the forms. A roll of paper 22 is mounted at the end of the press, as shown, and the web from the same is led between rollers 23, 24, and 25 to guiding-rollers 26 and 27, and from roller 27 over loop-roller 28, and thence to guiding-roller 29.

The looping-roller 28 is mounted in frames 30, and is raised and lowered vertically by means of cams 32 and rollers 31. From the roller 29 the web passes around guide-roll 8, under the impression-cylinder, then around guide-roll 9, up over turner-bar 11, across to turner-bar 12, over the same, down under roll 9, then under the impression-cylinder again, and up over roll 10. This will, as shown, transfer the web laterally and will properly present the unprinted side of the web, whereby the web will be perfected; also, it will be seen that the clean or unprinted side of the web runs on the turner-bars 11 and 12, whereby the same will not smut. From the roll 10 the web passes between guiding-rollers 33 and 34, around looping-roller 37, and then between rollers 35 and 36. The looping-roller 37 is mounted in suitable frames 38, which are raised and lowered vertically by means of cams 39, bearing on rollers 40, mounted in the frames 38.

The preferred way of mounting the turner-bars 11 and 12 is shown in Fig. 4. In this case the feet of the turner-bars, instead of being horizontal, are made vertical, as at 30, and are secured to blocks 32 by screws 31, and these blocks 32 are mounted so as to be capable of vertical adjustment in the carriage-frames 6 and 7 by means of screws 33.

It is evident, of course, that the feet of the turner-bars may be either vertical and secured to the sides of the block, as shown in Fig. 4, or they may be horizontal, as shown in Fig. 3, and secured to the top of the blocks.

By adjusting the screws 33 the turner-bars may be moved up and down, whereby register may be obtained between the two parts of the web which are presented by the cylinder; and, again, it will be evident that by adjusting the screws 33 independently the turner device may be adjusted so that the deflected web will properly and nicely turn on the same.

The operation of my device is apparent and is as follows: The rollers 23, 24, and 25 may, if desired, be continuously driven at a slow speed, whereby the web will be slowly unwound at an even speed from the roll. As the looping-roller 28 rises it will take up the web thus unwound from the roller 22. The web between roller 29 and rollers 33 and 34 is held stationary while the impression-cylinder is bearing on the forms, but when the impression-cylinder is reversing the looping-rollers 37 and 28 will be lowered by the cams and the slack web from roller 28 will be transferred over to roller 37. This will draw the web rapidly forward around the impression-cylinder, its guiding-rollers, and turner device, and will thereby feed the web forward, so that at the next movement of the cylinder a fresh surface of the web will be presented to the forms. This action takes place, of course, at the end of each stroke in either direction of the impression-cylinder, whereby the cylinder will print both ways, and as this particular mechanism forms no part of this

invention it is not thought necessary to describe the same further at length, except it may be noted that, if desired, the rollers 35 and 36 may be continuously driven in the same direction at the same peripheral speed as rollers 23, 24, and 25. It will be seen, therefore, that at each stroke in either direction, or half-turn of the crank-wheels, a portion of the web will be perfected, and that at the end of each half-revolution of the crank-wheels 17 and 18 the feeding device will operate to draw a new portion of the web under the impression-cylinder. As the impression-cylinder reciprocates over the forms, as before stated, the web between roller 29 and rollers 33 and 34 remains stationary, and as the cylinder 15 moves the web simply runs around the cylinder, its guiding-rollers, and turner device.

Among the advantages of my invention it may be noted that I have secured a web-perfecting press with a single traveling impression-cylinder, whereby the path of the web through the press will be very short and direct, and a press in which the operation will be rapid.

The various details herein shown and described may be greatly varied by a skilled mechanic, and the turner device may be of any form that will transfer the web laterally of the impression-cylinder, whether the same turns the web so that the same will be perfected or simply transfers the web laterally, whereby the web may be twice printed on the same side.

Having thus fully described my invention, what I claim, and desire to secure by Letters Patent, is—

1. The combination in a printing-press adapted to print on a web from forms, of a form-bed, an impression-cylinder, means for moving the impression-cylinder relatively to the bed, and means moving with the cylinder, adapted to transfer the web laterally of the cylinder, substantially as described.

2. The combination in a printing-press adapted to print on a web from forms, of a form-bed, an impression-cylinder, means for moving the impression-cylinder relatively to the form-bed, and a turner moving with the cylinder, adapted to transfer the web laterally of the cylinder, and to turn the same, whereby the web may be perfected, substantially as described.

3. The combination in a printing-press adapted to print on a web from forms, of a form-bed, an impression-cylinder, means for moving the impression-cylinder relatively to the form-bed, and a turner moving with the cylinder consisting of the right-angled bars 11 and 12 around which the web may be led and transferred laterally of the impression-cylinder, substantially as described.

4. The combination in a printing-press adapted to print on a web from forms, of a form-bed having forms arranged side by side, an impression-cylinder, means for moving the

impression-cylinder relatively to the form-bed, a carriage in which said impression-cylinder is mounted, and a turner also mounted on said carriage, adapted to transfer the web laterally of the impression-cylinder, substantially as described.

5 5. The combination in a printing-press of the class described, of the stationary form-bed, the carriage, means for reciprocating the carriage, an impression-cylinder mounted in the carriage, suitable guiding-rollers also mounted in said carriage, and a turner device mounted on said carriage around which the web is led, and thereby transferred laterally, substantially as described.

10 6. In a printing-press of the class described, the combination of the stationary form-bed, the reciprocating carriage, means for reciprocating the same, the impression-cylinder, guiding-rollers 8, 9 and 10, and turner-bars 11 and 12 carried by said carriage around which the web may be led, and thereby transferred laterally of the impression-cylinder, substantially as described.

15 7. The combination of a stationary form-bed, an impression-cylinder, means for reciprocating the same relatively to the form-bed, a turner moving with the cylinder, web-guides and web feeding or manipulating devices, substantially as described.

20 8. The combination in a printing-press adapted to print on a web from forms, of a form-bed, an impression-cylinder, means for moving the impression-cylinder relatively to the bed, and means for transferring the web laterally of the cylinder, and directing the

same twice around the cylinder, of an adjusting mechanism, whereby register may be obtained between the two portions of the web that pass around the cylinder, substantially as described.

9. The combination in a printing-press adapted to print on a web from forms, of a form-bed, an impression-cylinder, means for moving the impression-cylinder relatively to the form-bed, and a turner moving with the cylinder adapted to transfer the web laterally of the impression-cylinder, and to direct the web a second time around the cylinder, and means for adjusting the turner, whereby register may be obtained between the two portions of the web that pass around the cylinder, and proper action of the deflected web may be obtained upon the turner, substantially as described.

10. The combination in a printing-press adapted to print on a web from forms, of a form-bed, an impression-cylinder, means for moving the impression-cylinder relatively to the form-bed, and a turner moving with the cylinder consisting of the right-angled bars 11 and 12, the ends of said turner-bars being mounted on blocks, which blocks are adapted to be adjusted vertically, substantially as described.

In testimony whereof I have hereunto set my hand in the presence of two subscribing witnesses.

H. A. WISE WOOD.

Witnesses:

LOUIS W. SOUTHGATE,  
ELIZABETH M. HEALY.