

June 13, 1961

C. B. FORRESTER

2,987,835

SHOE FASTENING DEVICE

Original Filed July 26, 1954

2 Sheets-Sheet 1

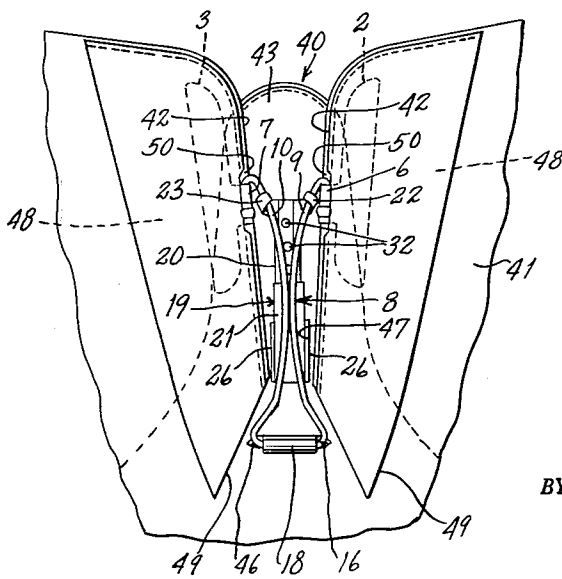
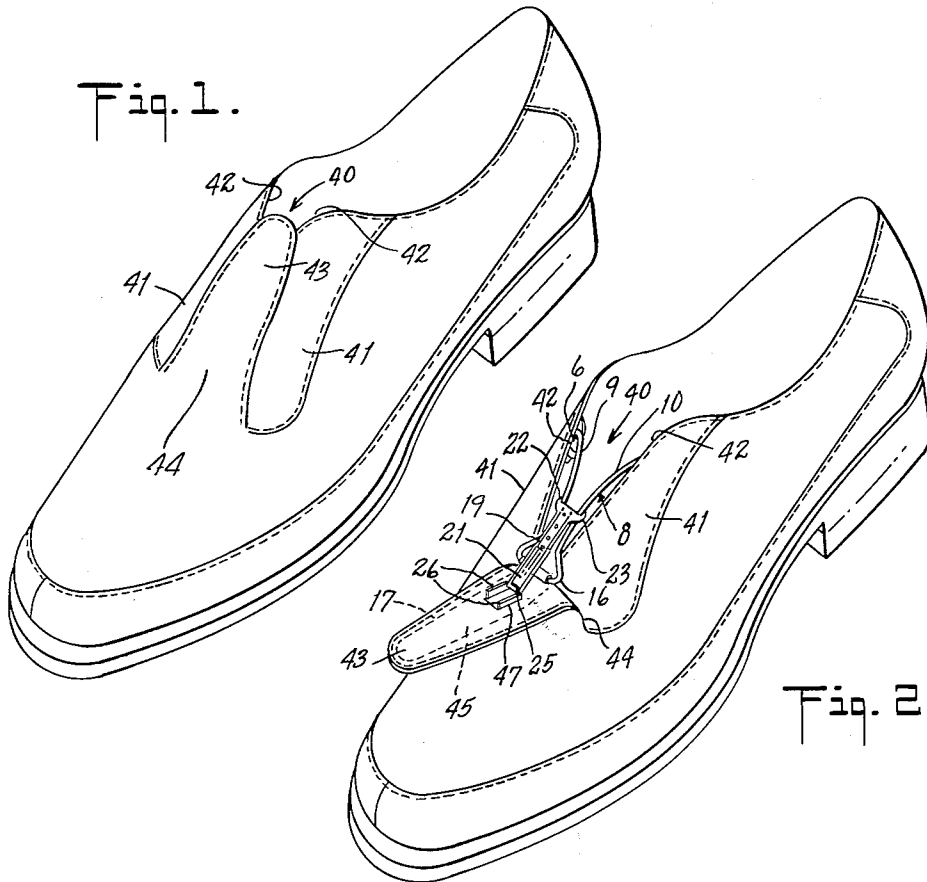

INVENTOR.  
CLIVE B. FORRESTER  
BY *R. E. Meach*  
ATTORNEY

June 13, 1961

C. B. FORRESTER  
SHOE FASTENING DEVICE

2,987,835

Original Filed July 26, 1954

2 Sheets-Sheet 2

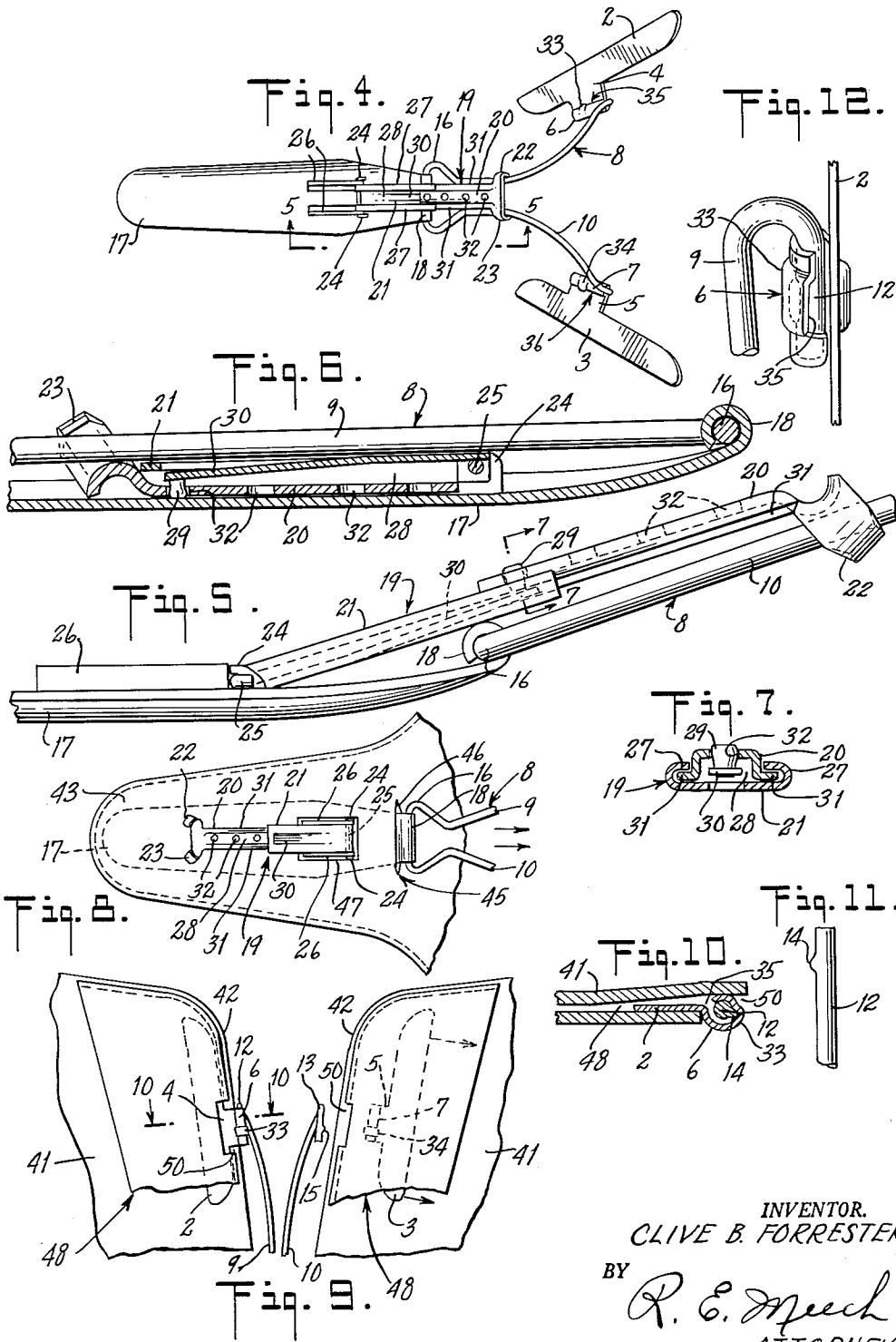

INVENTOR.  
CLIVE B. FORRESTER  
BY  
*R. E. Meach*  
ATTORNEY

1

2,987,835

**SHOE FASTENING DEVICE**

Clive B. Forrester, Miami, Fla., assignor to Talon, Inc.,  
a corporation of Pennsylvania

Original application July 26, 1954, Ser. No. 445,779, now  
Patent No. 2,969,573, dated Jan. 31, 1961. Divided  
and this application Feb. 11, 1960, Ser. No. 8,137

5 Claims. (Cl. 36-59)

This invention relates to fastening devices for shoes and more particularly to an improved fastening device for opening and closing the flaps of shoes.

This application is a division of my co-pending application Serial No. 445,779, filed July 26, 1954, now Patent No. 2,969,573.

It is the general object of the present invention to provide a new and improved fastening device for shoes which is an improvement over that shown in my above identified patent.

It is another object of the invention to provide an improved fastening device for shoes which not only can be conveniently incorporated with the shoe by the manufacturer, but can be easily and quickly replaced by the wearer in case of damage to the fastener.

It is a further object of this invention to provide an improved shoe fastening device which is strong and rugged in its construction and consists of a minimum number of parts which can be easily and inexpensively fabricated and assembled.

It is still another object of the present invention to provide an improved shoe fastening device having means incorporated therewith whereby the fastener can be easily and quickly adjusted to the instep of the wearer.

It is still a further object of this invention to provide a shoe fastening device which is so constructed and arranged with the shoe that it is completely hidden when closed so as not to detract from the appearance of the shoe but in fact, enhances the appearance of the shoe in that the opening therein is completely covered.

Various other objects and advantages of this invention will be more apparent in the course of the following specification, and will be particularly pointed out in the appended claims.

In the accompanying drawings there is shown for the purpose of illustration, an embodiment which my invention may assume in practice.

In these drawings:

FIG. 1 is a perspective view of a shoe having the improved shoe fastening device of my invention incorporated therewith showing the fastening device in its closed position,

FIG. 2 is a perspective view of a shoe similar to FIG. 1 showing the fastening device in its open position,

FIG. 3 is a fragmentary view of the inner side of the upper portion of the shoe as shown in FIG. 1,

FIG. 4 is a plan view of my improved shoe fastening device showing it in its open position,

FIG. 5 is an enlarged side view taken on line 5-5 of FIG. 4,

FIG. 6 is a longitudinal cross sectional view similar to FIG. 5 showing the fastening device in its closed position,

FIG. 7 is a sectional view taken on line 7-7 of FIG. 5,

FIG. 8 is a fragmentary view of the inner side of the tongue portion of the shoe as shown in FIG. 2, showing the rigid member disengaged from the arms of the resilient member.

FIG. 9 is an enlarged fragmentary view of the upper portion of the shoe as shown in FIG. 2, showing how the arms of the resilient wire member may be removed from the shoe,

FIG. 10 is a sectional view taken on line 10-10 of FIG. 9,

2

FIG. 11 is a fragmentary view of the upper portion of the end of one of the arms of the resilient wire member, and

FIG. 12 is an enlarged perspective view of the upper end of one of the arms of the resilient member showing how it is assembled in one of the wing members.

Referring more particularly to the drawings, and as more clearly shown in FIGS. 4 through 7, the improved shoe fastening device of the present invention comprises a pair of elongated substantially flat plate-like wing members 2 and 3 made preferably of relatively flat, thin metallic stock having projections 4 and 5, respectively, arranged along the inner marginal edges thereof. These projections 4 and 5 terminate in cylindrical bearing-like portions or bosses 6 and 7, respectively, for a purpose hereinafter to be described.

Between these wing members 2 and 3 there is arranged a relatively stiff resilient wire member 8 made of spring steel or some other suitable material which is bent to substantially V-shape so as to provide elongated arms 9 and 10 which terminate preferably in reversely bent positions 12 and 13, respectively, having knob-like portions or teats 14 and 15, respectively arranged on the outer ends thereof. These reversely bent end portions 12 and 13 are removably disposed in the respective bearing-like portions or bosses 6 and 7 of respective wing members 2 and 3. There is formed at the apex or neck of this V-shaped resilient wire member 8, a substantially oval-shaped portion so as to provide a transverse trunnion-like portion 16.

There is provided an elongated manipulating or actuating member 17 which is preferably relatively thin and substantially flat but may be arcuate shape in cross section. The trunnion-like portion 16 of the resilient member 8 is hingedly connected to the inner end of this manipulating member, as at 18.

A rigid member 19 is provided which extends between the manipulating member 17 and the arms 9 and 10 of the resilient wire member 8. This rigid member 19 consists preferably of two elongated channel-like parts or members 20 and 21 telescopically arranged for adjusting the length thereof. On the outer end of the upper part 20 there is arranged a yoke-shaped portion having a pair of hook-shaped ear portions 22 and 23 which slidably engage with and are disposed around the respective arms 9 and 10 of the resilient member 8. These hook-shaped ear portions 22 and 23 are spaced apart so as to permit the insertion and removal of the arms 9 and 10 therebetween. The outer end of the lower part 21 is pivotally connected to a pair of spaced-apart bearing portions 24 struck up from the body of the manipulating member 17 intermediate its length by means of a transversely extending pin 25 at a spaced distance from the hinged connection 18. Adjacent these bearing portions 24, there is also struck up from the body of the manipulating member 17, a pair of elongated parallel resilient portions or projections 26 which are spaced apart from one another a distance slightly less than the width of the part 21 of the rigid member 19 with which they are adapted to co-operate to lock the fastener in closed position in a manner to be described.

The lower part 21 of the rigid member 19 has upwardly and inwardly extending marginal flanges 27 so as to provide a channel 28 therebetween for slidably receiving the inner end of the part 20. Adjacent the inner end of this part 21, there is arranged a pin-like projecting portion 29 which is disposed on the end of a leaf-like spring portion 30 struck up from the central body portion of this part 21. There is arranged on the upper part 20 of the rigid member 19, laterally extending marginal flange portions 31 which are disposed in under the marginal flanges 27 and in the channel 28 of the lower part 21. Centrality of

the upper part 20, there is arranged a series of spaced apart apertures 32 with which the pin-like projection 29 of the lower part 21 engages to adjust selectively the two parts 20 and 21 relative to one another so as to adjust the length of the rigid member 19.

As hereinbefore stated, the reversely bent end portions 12 and 13 of the respective arms 9 and 10 are disposed in the respective bearing-like portions or bosses 6 and 7 of the respective wing members 2 and 3. There is provided in these bosses 6 and 7, enlarged cylindrical portions 33 and 34, respectively, for receiving and housing the respective knot-like portions or teats 14 and 15 carried by the respective reversely bent portions 12 and 13. On the inner side of these bosses 6 and 7, there is arranged slotted openings 35 and 36, respectively, for receiving the respective knob-like portions or teats 14 and 15. That is to say, the ends of the reversely bent end portions 12 and 13 are inserted in the respective bosses 6 and 7 with the respective knob-like portions or teats 14 and 15 positioned opposite the respective slotted openings 35 and 36 in the bosses with these teats passing down through the respective slotted openings and into the respective enlarged portions 33 and 34 thereby locking the wing portions 2 and 3 on the respective reversely bent end portions 12 and 13 of the respective arms 9 and 10 as more clearly shown in FIG. 12.

It will be understood that the hook-shaped ear portions 22 and 23 grasp the arms 9 and 10 of the resilient member 8 and draw them together as the yoke-shaped portion of the upper part 20 of the rigid member 19 slides therealong thereby drawing the wing members 2 and 3 toward one another. The rigid member 19 and in turn the arms 9 and 10 are moved by the manipulating member 17 and it will be seen that the manipulating member makes the largest angle with both the resilient member 8 and rigid member 19 when the manipulating member is in its open position, as shown in FIGS. 4 and 5, thereby permitting the arms 9 and 10 shown in FIG. 6, it will be seen that the manipulating to be spread apart. In the closed or locked position, as member 17 makes the smallest angle with both the resilient member 8 and the rigid member 19 and is disposed substantially parallel thereto, thereby holding the arms 9 and 10 inwardly against the inherent resilient force of these arms tending to spread them apart. In such closed position, it will be understood that the rigid member 19 is forced between and is positioned between the pair of elongated parallel inwardly extending projecting portions 26 of the manipulating member 17 which parallel portions are sprung and in engagement with the marginal flange portions 27 of the rigid member 19 so as to lock the manipulating member in locked position and to prevent unintentional movement thereof.

Having described the construction of my improved fastening device it is assembled in a shoe in the following manner. Attention is directed now more particularly to FIGS. 1 through 3 and 8 through 10 of the drawings wherein there is shown a shoe having the usual instep opening 40 and side instep or flap portions 41 and edges 42 bordering the opening 40. There is provided a flexible tongue-like member or covering flap 43 which is hingedly connected to the saddle portion of the shoe at the lower end of the opening 40, as at 44, which is adapted to cover the opening 40. The tongue-like member 43 is preferably made of two pieces of leather which are sewn together around their marginal edges so as to provide a pocket 45 therein having a transverse slotted opening 46 adjacent the bottom thereof on the inner side. There is also provided on the inner side of this tongue-like member 43, another substantially rectangular-shaped opening 47 which is positioned at a spaced distance above the slotted opening 46 and which also opens into the pocket 45.

It will be assumed that the hook-shaped ear portions 22 and 23 are disconnected from their sliding engage-

ment with the arms 9 and 10. The manipulating member 17 of the fastening device is first removably positioned in this pocket 45 in the tongue-like member 43 by inserting it through the slotted opening 46, and at the same time the upper end of the rigid member 19 is inserted through the rectangular-shaped opening 47. It will then be seen that the manipulating member 17 is positioned in the pocket 45 with the rigid member 19 extending out through the opening 47, as shown in FIG. 8 of the drawings. Also, in such position, it will be seen that the lower end of the manipulating member and hinge portion 18 carried thereby extends out through the slotted opening 46 to which the lower end of the resilient member 8 is hingedly attached.

It will be assumed that the wing members 2 and 3 of the fastening device are disconnected from the respective reversely bent portions 12 and 13 of the respective arms 9 and 10 of the resilient wire member 8. There is provided in each of the side instep portions 41 of the shoe, a pocket 48 having an opening 49 thereinto preferably at the bottom thereof, as shown in FIGS. 3 and 9. The wing members 2 and 3 are then inserted through these respective openings 49 so as to be positioned in these respective pockets 48 with the boss portions 6 and 7 extending out through slotted openings 50 arranged along the edges 42 and into the instep opening 40, as shown in FIGS. 3, 9 and 10. In such position, it will be seen that the resilient member 8 is positioned in the instep opening 40 between the opposed edges 42 of the instep.

The reversely bent end portions 12 and 13 of the respective arms 9 and 10 are then inserted in the respective bosses 6 and 7 in a manner that has been previously described. It will be seen that the arms 9 and 10 tend to maintain the wing members 2 and 3 in position in their respective pockets 48. The hook-shaped ear portions 22 and 23 of the rigid member 19 are then positioned around their respective arms 9 and 10 by inserting the arms in the space between the ear portions. This completes the assembly of the fastener in the shoe and it is now in readiness for use.

In operating the device the upper end of the tongue-like member 43 together with the manipulating member 19 housed therein, is grasped and moved inwardly toward the instep opening 40 until it is substantially flush with the instep side portions 41. In so doing it will be understood as previously described that the hook-shaped ear portions 22 and 23 will gradually draw the arms 9 and 10 together as they slide therealong which in turn draws the edges 42 of the instep opening 40 toward one another against the resilient action of the arms 9 and 10. When the tongue-like member 43 together with the manipulating member 17 has been moved to its fully closed position so as to cover the instep opening 40, the marginal flanges 27 of the rigid member 19 will force the projecting portions 26 apart by a snapping action and be held resiliently therebetween so as to lock the manipulating member 17 in its closed position thereby preventing accidental opening of the fastener, as shown in FIGS. 3 and 6.

The reverse procedure is followed to open the fastener and shoe. That is, the shoe is opened merely by grasping the tongue-like member 43 and pulling it outwardly whereby the rigid member 19 is moved from between the locking projecting portions 26 and causes the yoke-shaped portion together with the hook-shaped ear portion on the end of the rigid member to slide down along the arms 9 and 10 of the resilient member 8 to permit the instep opening to open widely, as shown in FIGS. 2 and 5 of the drawings.

As a result of my invention it will be seen that there is provided an improved shoe fastening device consisting of a minimum number of parts which can be easily and inexpensively fabricated and assembled. It will also be seen that this fastening device is so constructed and ar-

ranged that it can be conveniently assembled in and removed from the shoe in case of damage.

While I have shown and described an embodiment which my invention may assume in practice, it will be understood that this embodiment is merely for the purpose of illustration and description, and that other forms may be devised within the scope of my invention as defined in the appended claims.

What I claim as my invention is:

1. In combination with a shoe comprising an upper having a pair of side flaps bordering an opening therein and a tongue-like member which constitutes an extension of said upper for covering said opening, said extension being hinged relative to said upper at the lower end of said opening, a fastening device arranged in said opening comprising a pair of elongated wire members with one disposed along the marginal edge of each of said flaps and attached thereto, a manipulating member having one end thereof pivotally attached to the lower end of said elongated members adjacent the lower end of said opening, said elongated members and said flaps, said manipulating member being attached to said tongue-like member on the inner side thereof, a rigid member having one end thereof pivotally attached to said manipulating member at a spaced distance from its pivotal connection with the shoe, means arranged on the opposite end of said rigid member slidably engaging both of said elongated members, and means for holding the manipulating member together with said tongue in closed position so as to cover and conceal the fastener and the shoe opening.

2. In combination with a shoe having a pair of side flaps bordering an opening and a tongue-like member for covering said opening, said flaps having oppositely disposed slotted openings in the marginal edges thereof, a fastening device arranged in said shoe opening comprising a pair of wing members disposed in the slotted opening in said flaps, a resilient wire member bent to substantially V-shape so as to provide a pair of spaced-apart elongated arm-like portions disposed in said shoe opening having the outer ends of said arm-like portions connected to the respective wing members, said tongue-like member having a pocket therein, a manipulating member disposed in said pocket and having one end thereof pivotally attached to said wire member at the lower end thereof, a rigid member having one end thereof pivotally attached to said manipulating member at a spaced distance from its pivotal connection with said wire member, means arranged on the opposite end of said rigid member slidably engaging both of the arm-like portions of said wire member, means for adjusting the length of said rigid member, and means carried by said manipulating member which co-operates with means carried by said rigid member for locking the manipulating member in its closed position substantially parallel to the arms of said wire member whereby the tongue covers and conceals said wire member and said shoe opening.

3. In combination with a shoe having a pair of side flap portions bordering an opening and a tongue-like member hingedly connected to the shoe at the lower end of said opening, each of said flaps having a pocket ing device arranged in said opening comprising a pair of arranged therein to either side of said opening, a fasten-substantially flat plate-like wing members with one disposed in each of the pockets in said flap portions to either side of said opening, a resilient wire member bent to substantially V-shape so as to provide a pair of spaced-apart elongated arm-like portions disposed in said opening having the outer ends of the arm-like portions thereof detachably connected to the respective wing members, said tongue-like member having a pocket arranged therein, a plate-like manipulating member removably disposed in said pocket in said tongue and having its lower

end extending out through an opening therein, the lower end of said manipulating member being hingedly connected to said wire member at the lower end thereof, a rigid member extending between said manipulating member and said wire member, one end of said rigid member being pivotally connected to said manipulating member at a spaced distance from its pivotal connection with said wire member, the other end of said rigid member slidably engaging both of the arm-like portions of said wire member, and means for holding the assembly in closed position whereby the tongue-like member covers said wire member and said opening and the manipulating member is held in locked position so as to prevent unintentional opening of the fastening device.

4. In combination with a shoe comprising an upper having a pair of side flaps bordering an opening therein and a tongue-like member which constitutes an extension of said upper for covering said opening, said extension being hinged relative to said upper at the lower end of said opening, a fastening device arranged in said opening comprising a pair of elongated wire members with one disposed along the marginal edge of each of said flaps and being removably attached thereto, a manipulating member having one end thereof pivotally attached to the lower end of said elongated members adjacent the lower end of said opening and said flaps, said manipulating member being removably attached to said tongue-like member on the inner side thereof, a rigid member having one end thereof pivotally attached to said manipulating member at a spaced distance from its pivotal connection with the shoe, means arranged on the opposite end of said rigid member slidably engaging both of said wire members whereby the marginal edges of said flaps are moved toward or away from one another upon actuation of said manipulating member, and means for holding the manipulating member together with said tongue in closed position so as to cover and conceal the fastener and the shoe opening.

5. In combination with a shoe comprising an upper having a pair of side flaps bordering an opening and a tongue-like member which constitutes an extension of said upper for covering said opening, said extension being hinged relative to said upper at the lower end of said opening, a fastening device arranged in said shoe comprising a resilient wire member bent to substantially V-shape so as to provide a pair of spaced-apart elongated arm-like portions disposed along the marginal edges of said flaps, means carried by each of said arm-like portions for attaching them to the marginal edges of the respective flaps, a manipulating member having one end thereof pivotally attached to said wire member at the lower end thereof, means for attaching said manipulating member to said tongue-like member on the inner side thereof, a rigid member having one end thereof pivotally attached to said manipulating member at a spaced distance from its pivotal connection with said wire member, means arranged on the opposite end of said rigid member slidably engaging both of the arms of said wire member whereby the marginal edges of said flaps are moved toward or away from one another upon actuation of said manipulating member, and means carried by said manipulating member which co-operates with means carried by said rigid member for locking the manipulating member in its closed position substantially parallel to the arms of said wire member whereby the tongue covers and conceals said wire member and said shoe opening.

#### References Cited in the file of this patent

##### UNITED STATES PATENTS

2,637,087 Forrester ..... May 5, 1953

##### FOREIGN PATENTS

579,941 France ..... Oct. 27, 1924