

(19) World Intellectual Property Organization  
International Bureau



(43) International Publication Date  
15 March 2007 (15.03.2007)

PCT

(10) International Publication Number  
WO 2007/030414 A2

(51) International Patent Classification:  
A61F 2/06 (2006.01)

(21) International Application Number:  
PCT/US2006/034411

(22) International Filing Date:  
5 September 2006 (05.09.2006)

(25) Filing Language: English

(26) Publication Language: English

(30) Priority Data:  
11/221,242 7 September 2005 (07.09.2005) US

(71) Applicant and

(72) Inventor: PARK, Richard, B. [US/US]; 1155 Crabapple Lane, St. Charles, Illinois 60174 (US).

(74) Agents: SHELDON, Stephen, L. et al.; BANNER & WITCOFF, LTD., 10 S. Wacker Drive, Suite 3000, Chicago, Illinois 60606-7407 (US).

(81) Designated States (unless otherwise indicated, for every kind of national protection available): AE, AG, AL, AM,

AT, AU, AZ, BA, BB, BG, BR, BW, BY, BZ, CA, CH, CN, CO, CR, CU, CZ, DE, DK, DM, DZ, EC, EE, EG, ES, FI, GB, GD, GE, GH, GM, HN, HR, HU, ID, IL, IN, IS, JP, KE, KG, KM, KN, KP, KR, KZ, LA, LC, LK, LR, LS, LT, LU, LV, LY, MA, MD, MG, MK, MN, MW, MX, MY, MZ, NA, NG, NI, NO, NZ, OM, PG, PH, PL, PT, RO, RS, RU, SC, SD, SE, SG, SK, SL, SM, SV, SY, TJ, TM, TN, TR, TT, TZ, UA, UG, US, UZ, VC, VN, ZA, ZM, ZW.

(84) Designated States (unless otherwise indicated, for every kind of regional protection available): ARIPO (BW, GH, GM, KE, LS, MW, MZ, NA, SD, SL, SZ, TZ, UG, ZM, ZW), Eurasian (AM, AZ, BY, KG, KZ, MD, RU, TJ, TM), European (AT, BE, BG, CH, CY, CZ, DE, DK, EE, ES, FI, FR, GB, GR, HU, IE, IS, IT, LT, LU, LV, MC, NL, PL, PT, RO, SE, SI, SK, TR), OAPI (BF, BJ, CF, CG, CI, CM, GA, GN, GQ, GW, ML, MR, NE, SN, TD, TG).

Published:

— without international search report and to be republished upon receipt of that report

For two-letter codes and other abbreviations, refer to the "Guidance Notes on Codes and Abbreviations" appearing at the beginning of each regular issue of the PCT Gazette.

(54) Title: CORONARY STENT

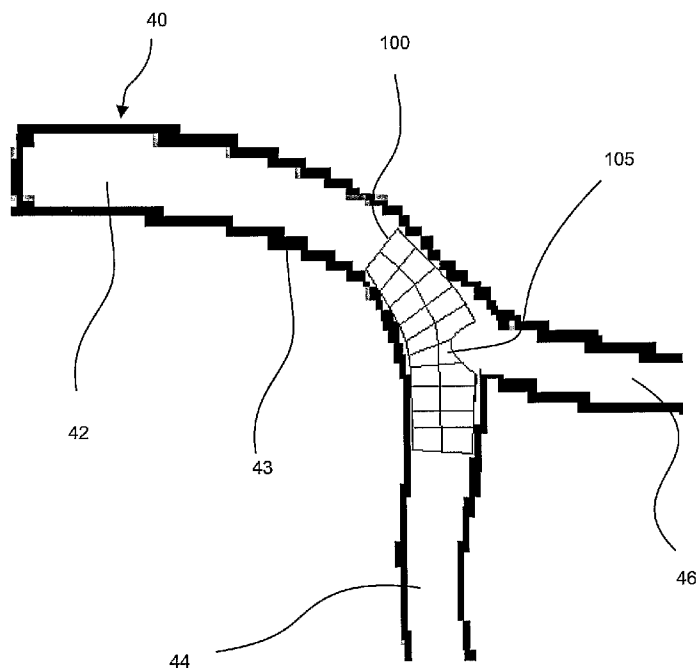

(57) Abstract: In an embodiment, a stent is provided for use in blood vessels with blockage near or in a bifurcation. The stent includes a side aperture. The stent is inserted into one of the daughter branches of the bifurcation and positioned with the use of markers. The stent is then expanded so as to support the wall of the blood vessel while allowing the blood to continue to flow to both daughter branches.



WO 2007/030414 A2

## CORONARY STENT

### BACKGROUND OF THE INVENTION

### FIELD OF THE INVENTION

[01] The present invention relates to the field of medical devices, more specifically to the field of implantable coronary stents.

### DESCRIPTION OF RELATED ART

[02] As is known, the human heart circulates blood throughout the body. Depending on the individual, the heart beats between 80,000 and 140,000 times per day. During normal function of the heart, the left and right atria and the left and right ventricles contract, causing blood to flow. The blood flows from the heart, passes through a set of blood vessels known as arteries that feed the organs and tissue in the body and then returns to the heart through a set of blood vessels known as veins. This circulation provides nutrients and oxygen to the body so that it can continue to function.

[03] As the heart is basically a continuously functioning muscle, it also needs a steady supply of nutrients in order to function. For example, a coronary artery supplies blood (and the associated oxygen and nutrients) to the cardiac muscle. In order for the heart to continue to function, it is crucial that this artery continue to function properly.

[04] Unfortunately, the coronary artery can become partially or completely blocked. One cause is left main coronary artery disease ("LMCD"). LMCD may be caused, for example, by the accumulation of fatty tissue on the wall of the left main artery. LMCD is generally defined as a greater than 50% reduction in the left main, which results in insufficient blood flow to the heart tissue and eventually causes damage to the heart tissue.

[05] While partial blockage can result in permanent damage to the heart muscle, sudden complete blockage of the left main will result in the death of the individual. Therefore, maintaining blood flow through the left main is crucial to an individual's ability to exist. Any symptomatic blockage must be immediately treated.

- [06] Two methods of treatment of a partially or completely blocked left main are 1) percutaneous transluminal coronary angioplasty (“PTCA”), also referred to as percutaneous coronary intervention (“PCI”), and commonly referred to as balloon angioplasty or angioplasty, and 2) coronary artery bypass graft (“CABG”), commonly referred to as bypass surgery. Due to a number of factors, the most common procedure to treat LMCD has been bypass surgery.
- [07] In essence, bypass surgery uses section of veins or arteries sections from other parts of the body to connect the aorta to a point downstream of the blockage. This allows blood to flow around the blockage point through a separate passageway. Depending on the severity and location of the blockage, as many as four to five grafts are necessary.
- [08] One downside to bypass surgery is that it takes a substantial time to perform. For a patient with a totally occlusion or a severely blocked left main, the time it takes to perform bypass surgery may be too long. Therefore, in emergencies, balloon angioplasty has been performed on patients suffering from sudden LMCD.
- [09] Another problem is that bypass surgery is only effective for about 8-10 years, at which point a patient generally requires additional treatment that is generally less effective. Given the potential long-term health problems, it is desirable to delay bypass surgery if possible.
- [10] Furthermore, certain patients’ medical conditions are incompatible with the rigors of bypass surgery. For example, some patients have severe co-morbid conditions precluding open-heart surgery, such as malignancy with limited life-expectancy, no longer are a candidate for bypass surgery. Thus, while bypass surgery is a useful medical procedure that has saved many lives, it is best saved for situations where less complex procedures cannot be used effectively.
- [11] In addition, some interventional cardiac catheterization labs are not backed up by surgical programs. This is problematic in situations where the LMCD must be treated immediately (e.g. iatrogenic dissection of the left main).
- [12] Compared to bypass surgery, angioplasty can be done relatively quickly and is generally less traumatic to the patient. Basically, during angioplasty a wire is inserted

into the artery. A flexible catheter is then guided along the wire. A balloon attached to the catheter is positioned in the left main at the point of blockage and the balloon is inflated to open the artery. To keep the artery open, a stent may be placed in the left main. One common method of delivering the stent is to wrap it around the balloon. Thus, the inflation of the balloon causes the stent to expand into position. The stent acts as a scaffolding to support the wall of the artery and, when coated with anti-restenotic agents, can be an alternative means of treating certain types of LMCD.

- [13] While the expansion of blocked portions of arteries with angioplasty can be effective, certain areas of the left main have proven difficult to treat with balloon angioplasty. Sometimes the blockage occurs at a point of junction between the left main and the left anterior descending artery and the left circumflex artery. In such a situation, expansion and insertion of a stent into one of the secondary branches has the tendency to jeopardize the other branch.
- [14] Attempts have been made to provide a customized stent that can be used in a junction to support the main branch and the two secondary branches but such an approach has limitations. For one thing, the secondary branches and angles between the different branches are varied from person to person as well as from junction to junction, making it difficult to design a single stent that can work with all the potential variations. Furthermore, such a design is difficult to install, thus making it less attractive to locations such as the junction in the left main. Another major limitation is that much higher operator skill is required to position such a stent quickly, thus making it more likely that such a stent will be improperly installed.
- [15] Therefore, often the only choice is to attempt bypass surgery. However, in the face of complete blockage it is possible that a patient will not survive the procedure. Clearly, something more is needed to address such a life-threatening emergency. In addition, it would be beneficial to provide a stent that could be used in and near the left main junction during more routine medical situations as an alternative to bypass surgery.

#### BRIEF SUMMARY OF THE INVENTION

- [16] A method and apparatus for treating coronary disease is disclosed. In an embodiment, a stent with a side aperture is inserted into a junction of a left main coronary artery that

includes a main branch and two secondary branches so that the side aperture aligns with one of the secondary branches while the stent extends into the other secondary branch. The stent is expanded so as to support a wall of the left main coronary artery while allowing blood to flow through the side aperture into one of the secondary branches. In an embodiment, the stent may be coated with a pharmaceutical agent.

#### BRIEF DESCRIPTION OF THE DRAWINGS

- [17] The present invention is illustrated by way of example and not limited in the accompanying figures in which like reference numerals indicate similar elements and in which:
- [18] Figure 1 illustrates an embodiment of a human heart.
- [19] Figure 2 illustrates an enlarged view of the human heart in Figure 1, illustrating the left main coronary artery.
- [20] Figure 3 illustrates a further enlarged view of the left main coronary artery of the human heart depicted in Figure 2.
- [21] Figure 4 illustrates an embodiment of blockage in an artery of a human heart in accordance with an aspect of the present invention.
- [22] Figure 5 illustrates an alternative embodiment of blockage in an artery of a human heart in accordance with an aspect of the present invention.
- [23] Figure 6a illustrates an alternative embodiment of blockage in an artery of a human heart in accordance with an aspect of the present invention.
- [24] Figure 6b illustrates an alternative embodiment of blockage in an artery of a human heart in accordance with an aspect of the present invention.
- [25] Figure 7 illustrates an embodiment of a guide wire being inserted into coronary in accordance with an aspect of the present invention.
- [26] Figure 8 illustrates an embodiment of an angioplasty balloon being inserted into coronary in accordance with an aspect of the present invention.

- [27] Figure 9 illustrates a top view an embodiment of a stent in accordance with an aspect of the present invention.
- [28] Figure 10 illustrates a side view of the stent in Figure 9 in accordance with an aspect of the present invention.
- [29] Figure 11 illustrates a side aperture of a stent in accordance with an aspect of the present invention.
- [30] Figure 12 illustrates a sectional view of an embodiment of a stent implanted in accordance with an aspect of the present invention.
- [31] Figure 13 illustrates a sectional view of an embodiment of a guide wire being inserted in accordance with an aspect of the present invention.
- [32] Figure 14 illustrates a sectional view of an embodiment of a stent being implanted in accordance with an aspect of the present invention.
- [33] Figure 15 illustrates a sectional view of an embodiment of a stent being implanted in accordance with an aspect of the present invention.
- [34] Figure 16 illustrates an elevated view of an embodiment of a support structure created by two stents in accordance with an aspect of the present invention.
- [35] Figure 17 illustrates an elevated view of an embodiment of a support structure created by two stents in accordance with an aspect of the present invention.
- [36] Figure 18 illustrates an elevated view of an embodiment of a stent in accordance with an aspect of the present invention.
- [37] Figure 19 illustrates an elevated view of an embodiment of two markers in accordance with an aspect of the present invention.
- [38] Figure 20 illustrates an alternative elevated view of an embodiment of the two markers in Figure 19 in accordance with an aspect of the present invention.
- [39] Figure 21 illustrates an alternative elevated view of an embodiment of the two markers in Figure 19 in accordance with an aspect of the present invention.

- [40] Figure 22 illustrates a top view of an alternative embodiment of a stent in accordance with an aspect of the present invention.
- [41] Figure 23 illustrates a side view of the stent depicted in Figure 22 in accordance with an aspect of the present invention.
- [42] Figure 24 depicts a stent in a compressed state in accordance with an aspect of the present invention.

#### DETAILED DESCRIPTION OF THE INVENTION

- [43] The description below will discuss various medical conditions and how a stent may be used to aid in the treatment these medical conditions. It is noted that the methods and apparatus disclosed are not limited to the treatment of the medical conditions disclosed but may be used to treat other medical conditions where appropriate.
- [44] Looking first at Figure 1, an embodiment of a heart 10 is depicted. The heart 10 is fed by a right coronary artery 20 that branches out and provides blood to a portion of the heart. A left coronary artery 40 is also shown and also branches out and provides blood to a portion of the heart. As can be appreciated, a blockage at the beginning or proximal end 41 of the left coronary artery 40 would affect the flow of blood to all points downstream while a blockage at the distal end 49 of the left coronary artery 40 might have little or no discernable effect on the viability of the heart 10.
- [45] Turning to Figure 2, the left coronary artery 40 is shown in an enlarged view that includes the left main artery or main branch 42 that feeds a first branch 44 (which as depicted is the left anterior descending artery) and a second branch 46 (which as depicted is the left circumflex artery).
- [46] As depicted, the first branch Figure 3 shows a further enlarged view of the left coronary artery 40. The main branch 42 forms a junction 50 where it bifurcates into the first branch 44 and the second branch 46. As can be further appreciated, the main branch 42 includes a wall 43. In order for blood to flow through the left coronary artery 40, the wall 43 forms a tube-like shape that preferably is free from blockage.

- [47] Unfortunately, as shown in Figure 4, a blockage 62 may be formed by, for example, deposits of fatty tissue on the wall 43 in the junction 50. In Figure 4, the blockage 62 partially occludes the flow of blood into the second branch 46. Figure 5 depicts a similar situation except that the blockage 64 partially occludes the first branch 44.
- [48] Figure 6a illustrates a blockage 66 in the junction 50 that occludes blood flow to both the branch 44 and the branch 46. Figure 6b illustrates a blockage 68 that is not within the junction 50 but affects blood flow to the first branch 44 and the second branch 46. As can be appreciated by Figures 4-6b, blockage in or near the junction 50 tends to require a solution that allows blood to flow to both branches 44, 46. It is noted that numerous other configurations of blockage near or in the junction 50 are possible. In an embodiment the blockage will occlude the main branch; in alternative embodiments the first branch or the second branch or a combination of two or more branches will be occluded by the blockage.
- [49] Turning to Figure 7, an illustration of the left coronary artery 40 without any blockage depicted is provided, the blockage being omitted for the sake of clarity. In an embodiment a guide wire 70 may be inserted into the left coronary artery 40 in a known manner. As depicted, the guide wire 70 is inserted into the junction 50 and extends into the first branch 44. As can be appreciated, the distance the guide wire 70 extends into the junction 50 may be adjusted depending on the location of the blockage.
- [50] Turning to Figure 8, after the guide wire is inserted, the next step is to guide a catheter 80 connected to an angioplasty balloon ("balloon") 90 along the guide wire into the desired position. Once the balloon 90 is correctly positioned, the balloon 90 is inflated so as to open up the portion of the left coronary artery 40 that was stenosed by the blockage. To help keep the left main open, the balloon 90 includes a stent 100 mounted on the exterior of the balloon 90. When the balloon 90 is expanded to open up the passageway, the stent 100 is also expanded. Once the passageway is opened, the pressure inflating the balloon 90 is removed and the balloon 90 contracts. However, the stent 100 remains in position so as to provide support for the wall 43 of the left coronary artery 40.
- [51] It should be noted that the balloon 90 may be compliant or non-compliant, depending on the intended use. Generally speaking, balloons that are non-complaint have a fixed

amount of expansion and do not effectively increase in diameter in response to increases in internal pressure. In contrast, balloons that are compliant do effectively increase in diameter in response to increases in internal pressure. The balloon 90 may also be semi-compliant and thus provide some minimal amount of expansion in response to greater pressure. While different levels of compliance may be suitable for different situations, a non-compliant balloon may be useful to prevent the balloon 90 from expanding in the area where the side aperture is provided.

- [52] One concern regarding the use of angioplasty is restenosis. Restenosis, or the re-narrowing of the arteries, affects a percentage of patients receiving angioplasty. While the use of a stent in combination with the angioplasty has significantly reduced the occurrence, restenosis is still an issue. To address this potential problem it may be desirable to coat the stent with a pharmaceutical agent. While different pharmaceutical agents work differently, in an embodiment, the drug coating may be configured to provide an anti-restenotic or anti-neointimal proliferation effect. In an embodiment, the coating may be RAPAMYCIN or SIROLIMUS.
- [53] As can be appreciated from Figure 8, using a standard stent in the junction 50 would be problematic. For example, in Figure 8 if a standard stent was used, when the stent was expanded the passageway to the second branch 46 would be at least partially blocked.
- [54] Looking at Figure 9, an alternative to the normal stent is depicted as stent 100. The stent 100 has a proximal end 101, a distal end 102 and includes a side aperture 105, a first marker 112 and a second marker 110. The use of the markers will be discussed below. Figure 10 illustrates a side view of the stent 100. As can be appreciated from Figures 9 and 10, the side aperture 105 is circular.
- [55] In an embodiment it may be desirable to provide a side aperture that is elongated on one side. Figure 11 illustrates an embodiment of a side aperture 105 that includes a center line 106 and is elongated on one side of the centerline 106.
- [56] Looking ahead to Figures 22 and 23, an alternative embodiment of a stent 100 is depicted. The stent 100 includes a proximal end 101 and a distal end 102. A cylinder wall 104 that opens at the proximal end 101 and the distal end 102 includes a side aperture 105. It should be noted that the cylinder wall 104 of the stent 100 is configured

to allow the stent 100 to expand. Thus, the cylinder wall 104 may comprise any of the known wall designs used for expanding stents. As can be appreciated, the side aperture 105 is shown with a center line 106. It is noted that in practice the center line 106 would not be visible and is thus being provided as a reference for purpose of discussion. As depicted, the side aperture 105 is elongated on one side of the center line 106, thus making it more difficult to define the true center. For purpose of discussion, however, the center line 106 as used herein refers to an imaginary reference line on the side aperture 105 that the operator should attempt to align with the center of the second branch 46 (Figure 3). As can be appreciated, as the center line 106 is an imaginary reference line that is not visible to the operator, the markers that may be provided on the stent 100 can aid the operator in performing the alignment process. Thus, the markers may aid the operator in effectively aligning the center line 106 with the side branch 46. It is noted that in an embodiment the first marker 112 may be aligned with the center line 106.

- [57] It should be noted that as depicted the side aperture 105 provides a relatively smooth edge 109 in the cylinder wall 104. While not required, this allows a second stent to be inserted through the side aperture 105 with less likelihood of snagging the stent 100 and moving it out of location or breaking off a piece of the stent 100. As can be appreciated, the occurrence of such events is difficult to detect but generally requires emergency surgery if detected in time, and therefore is undesirable. It should be noted that in an embodiment the size of the side aperture 105 may be substantially the same as the openings in the stent 100 at the proximal and distal ends 101, 102 so as to provide substantially the same effective lumen for each branch.
- [58] Referring to Figure 22, a first marker 112, partially provided in dotted line, extends around a portion of the circumference of the stent 100. As can be appreciated, this configuration, while not required, is helpful in positioning the stent. As can be further appreciated, the stent includes a second marker 110 that has a first half on one side of top of the stent and a second half on the bottom of the stent 100. This allows the second marker 110 to effectively extend the length of the stent 100 while providing additional information to the operator during implantation of the stent. For example, if the viewing angle is properly aligned, the second marker 110 will appear to be a continuous

line. Of course, in an alternative embodiment the second marker 110 may be a continuous line.

- [59] In an embodiment, the second marker 110 may be aligned with the longitudinal axis of the stent 100. In an alternative embodiment, the second marker 110 may be aligned parallel to the longitudinal axis of the stent 100. As can be appreciated, a parallel configuration may provide more precise feedback to the operator during implantation but requires additional manufacturing precision.
- [60] It should be noted that the first marker 112 may be positioned so as to be perpendicular to the second marker 110. While such a position is not required, if the second marker 110 is parallel to the longitudinal axis and the first marker 112 is perpendicular to the second marker 110, the position of the stent 100 can be more accurately determined prior to expansion of the stent 100.
- [61] In this regard, it should be noted that when the stent 100 is in the non-expanded state it is difficult to discern the location of the side aperture 105. Thus, the use of one or more markers that are visible while the stent 100 is still in the compressed state will tend to prevent the stent 100 from being expanded in an incorrect position. For example, as depicted in Figure 24, a non-expanded stent 100 is shown in two views and at least one of the first marker 112 and the second marker 110 is/are visible on the compressed stent 100 in either view.
- [62] Returning to Figure 12, a left coronary artery 40 is depicted with the stent 100 supporting the wall 43 from the main branch 42 to the first branch 44. However, to avoid blocking the second branch 46, the side aperture 105 is aligned so as to allow blood to flow through the stent 100 into the second branch 46. As can be appreciated, when installed the wall 43 will be in contact with most of the stent 100; thus, the stent 100 will act as a support structure to help ensure that blood flow to the branches 44, 46 remains non-obstructed.
- [63] While in many situations it may be sufficient to implant the stent 100, in other circumstances, such as depicted in Figure 6a, it may be beneficial to provide additional support for the wall 43. One way of doing so is to install a second stent. For example, a second stent extending from the side aperture 105 would provide a “Y” shaped

support structure (Figure 16) that could help ensure the blood continues to flow from the main branch 42 to the branches 44, 46.

- [64] To provide the “Y” shaped structure, first, as depicted in Figure 13, a guide wire 72 is inserted into the left coronary artery 40 and guided through the side aperture 105. This may be a different guide wire than the guide wire 70 or it may be the same guide wire. One potential issue with inserting a guide wire into the left coronary artery 40 after the stent 100 is implanted is that the guide wire 72 has a limited ability to bend and go around tight curves and could possibly catch on the stent 100. As previously discussed, in an embodiment the side aperture 105 may be elongated on one side. While not required, the elongated side aperture allows the guide wire 72 to be inserted into the second branch 46 while reducing the possibility that the guide wire might catch on the stent 100. In an alternative embodiment the side aperture 105 could simply be made larger.
- [65] Once the guide wire 72 is inserted, a catheter 82 is inserted along the guide wire 72 until the balloon 92 is positioned as desired. In an embodiment, as depicted in Figure 14, the balloon 92 extends out of the side aperture 105 and includes a stent 115 mounted to the outside of the balloon 92. In an embodiment the side aperture is elongated so that the balloon 92 and stent 115 pass through the side aperture 105 without catching on the stent 100. In an embodiment, when the stent 115 is expanded the stent 115 and stent 100 will have some overlap. In an alternative embodiment, the stent 115 will not overlap with the stent 100 but will be positioned via the side aperture 105. In another alternative embodiment, the stent 115 may be positioned first and then the stent 100 may be positioned so that the side aperture 105 aligns with the stent 115. To provide maximum support, however, it may be beneficial to have some overlap between the stent 100 and the stent 115.
- [66] In an alternative embodiment, as depicted in Figure 15, a guide wire 74 will be inserted past the proximal end 101 of the stent 100 and a catheter 84 with a balloon 94 will be inserted so that a portion of a stent 116 overlaps with the stent 100. The balloon 94 may then be inflated so that the stent 116 and stent 100 provide a more complex support structure. It should be noted that it may be useful to use a balloon 94 with a lesser degree of compliance so that the stent 116 is expanded in a uniform manner.

- [67] As illustrated in Figures 16 and 17, the stents 115, 116 are positioned and expanded to form a "Y" shaped support structure or an expanded tubular shaped support structure, respectively. In an embodiment, both the stent 115 and the stent 116 may be added to the stent 100 to maximize support of the left coronary artery 40. As can be appreciated, combinations of one or more stents 100, 115 and 116 may be used in an overlapping fashion; thus, a complex support structure is possible. It is expected, however, that one or two stents will typically be sufficient.
- [68] It should be noted that in an alternative embodiment the stent 115 may be a self-expanding stent. In such an embodiment, the stent 115 would be positioned and then allowed to expand. In an embodiment the self-expanding stent 115 would include one or more markers to allow the operator to more accurately determine where the proximal and/or distal ends are located.
- [69] As can be appreciated, the size of stent 100 may be adjusted as desired and used in other junction locations in different blood vessels. For example, the distance between the distal end 102 and the side aperture 105 may vary as desired. In addition, different locations may require an outer diameter 103 of the stent 100 (Figure 10) to be adjusted so as to provide proper support for the wall of the blood vessel.
- [70] It should be noted that in an embodiment a stent 100 may be inserted after the balloon is expanded a first time. In such an embodiment, a first balloon would be expanded and then contracted. The first balloon would then be removed. Next the stent 100 would be installed. In such a scenario the stent 100 could be a self-expanding stent or a balloon expanded stent as discussed above. Thus, expanding a stent includes using a balloon to expand the stent or allowing the stent to self-expand. As the general procedure for inserting and expanding a stent in an artery is known to persons of skill in the art, additional details are not provided herein.
- [71] As can be appreciated, care must be used when positioning the stent 100 and the side aperture 105 and the optional stents 115, 116 or the support structure will not work as intended. For example, it is beneficial to align the side aperture 105 with the second branch 46 so as to avoid occlusion of the second branch 46.

- [72] In an embodiment, the stent may be made of a stainless steel alloy, although other materials may be used. It is noted that the type of stent is not crucial; thus, for example but without limitation, a coiled spring design, a slotted tube design or mesh design may be used. However, one potential issue with the insertion of stents is that under certain known viewing methodologies the stent will not be visible (e.g. the stent will be radiolucent). Even if the stent is not radiolucent, seeing the stent without being able to determine its orientation can make aligning the side aperture more difficult.
- [73] To allow for improved orientation of the stent, radio-opaque markers may be included on the stent. In an embodiment the markers may include a gold coating; however, other coatings may also be used. Looking at Figure 18, a stent 100 includes a first marker 112, a second marker 110, a third marker 113 and a fourth marker 114. In an embodiment, as depicted, the first marker 112 and the second marker 110 may be perpendicular in orientation. The third and fourth markers 113, 114 may be positioned on proximal end 101 and distal end 102 of the stent 100. In an embodiment, a stent may have one or more of the markers as is appropriate. As can be appreciated, other shapes of markers other than lines may also be used.
- [74] It should also be noted the first marker 112 may include several distinct symbols that together form the first marker 112. Thus, the term marker refers to a set of one or more symbols, and may be, for example and without limitation, a set of dots, a geometric shape or some other configurations that allows the operator to determine aspects of the orientation of the stent 100. An advantage of using a line, however, is the ease of viewing such a marker during implantation of the stent.
- [75] In an embodiment, the first marker 112 may extend around a radial portion of the stent 100 as depicted in Figure 18. In an embodiment, the first marker 112 may extend around about half of the stent 100. While not required, the advantage of having the first marker 112 extend around about half of the stent 100 can be appreciated in light of Figures 19 and 20. If the orientation of the stent is aligned with the angle of viewing, the first marker 112 will look like a straight line, as illustrated in Figure 19. If the orientation of the stent 100 is not aligned with the viewing angle, the first marker 112 will resemble the appearance of the first marker 112 in Figure 20. As can be

appreciated, this allows the operator positioning the stent 100 in the blood vessel to determine and/or verify the angular orientation of the stent 100.

- [76] In addition to allowing the determination of angular orientation, configuring the stent 100 to include the first marker 112 with the first marker 112 being "C" shaped can also allow the operator to determine whether the rotational orientation of the stent is correct as illustrated by Figure 21. Thus, the angular and rotational orientation may be determined with the first marker 112 so that the stent 100 is properly positioned before being expanded.
- [77] In an embodiment, the first marker 112 may be directly aligned with the centerline 106 (Figure 23) of the side aperture 105. Thus, the operator positioning the stent 100 can line up the first marker 112 with the middle of the second branch 46 (Figure 3) so as to maximize blood flow to the second branch 46. As can be appreciated, however, the first marker 112 may also be aligned with some other part of the side aperture 105.
- [78] In an embodiment, the first marker 112 may extend the length of the stent 100. While not required, such a configuration aids in the implantation of additional stents. For example, in an embodiment a support structure as depicted in Figure 16 may be desired. To provide the depicted support, first the stent 100 with the side aperture 105 may be installed. The first and second markers 110, 112 allow the stent 100 to be properly orientated with respect to the second branch 46 before the stent 100 is expanded (Figures 8 and 9). In an embodiment the stent 115 may include the third and fourth markers 113, 114, which may be aligned with the proximal and distal ends of the stent 115, thus allowing the stent 115 to be aligned with respect to first and second markers 110, 112. Therefore, a stent 115 with the third and fourth markers 113, 114 may be positioned so as to partially extend from the side aperture 105 (Figure 14).
- [79] If the support structure as depicted in Figure 17 is desired, in an embodiment where the first marker 112 extended the length of the stent 100, the fourth marker 114 on the stent 115 could be positioned with respect to the first marker 112 on the stent 100. Thus, in an embodiment it could be determined when there was an overlap because the two markers 110, 114 would cross in a two-dimensional view. It should be noted that the same stent 115 may be used in either configurations shown in Figures 16 and 17. In an alternative embodiment, however, a different stent may be used. The advantage of

using the same stent to obtain either the structure in Figure 16 or Figure 17 is a reduced number of parts, thus reducing the chance that the wrong stent will be used. However, having a variety of different sized stents may allow for a more precise fit if such a fit is found to be useful for a particular patient. For example, the secondary branch might be much smaller than the main branch and thus would benefit from a stent with a smaller outer diameter.

[80] The present invention has been described in terms of preferred and exemplary embodiments thereof. Numerous other embodiments, modifications and variations within the scope and spirit of the appended claims will occur to persons of ordinary skill in the art from a review of this disclosure.

We claim:

1. A stent for supporting a wall of a blood vessel comprising:  
a cylinder wall, the cylinder wall having a circumference;  
a side aperture in the cylinder wall, the side aperture having a centerline; and  
a marker provided on the cylinder wall, the marker aligned with the side aperture.
2. The stent of claim 1, wherein the marker is a line extending a portion of distance around the circumference of the cylinder wall and the marker is directly aligned with the centerline of the side aperture.
3. The stent of claim 1, wherein the marker is a first marker, the stent further comprising a second marker aligned with the longitudinal axis of the cylinder wall.
4. The stent of claim 3, wherein the first marker and the second marker are substantially perpendicular to each other.
5. The stent of claim 1, wherein cylinder wall includes a wall structure, the wall structure selected from the group consisting of a mesh design, a coil spring design and a slotted tube design.
6. The stent of claim 1, wherein the cylinder wall is self-expanding.
7. A method for supporting a wall in a junction of a blood vessel, the junction comprising a main branch, a first branch and a second branch, the method comprising:
  - (a) inserting a stent with a side aperture into the junction, the stent extending into the main branch and the first branch, the stent including a marker aligned with the side aperture;
  - (b) aligning the marker with the second branch of the junction; and
  - (c) expanding the stent so as to support the wall of the blood vessel.
8. The method of claim 7, wherein the main branch is the left main, wherein the first branch is one of either the left anterior descending artery or the left circumflex artery and the second branch is the other of the left anterior descending artery or the left circumflex artery.

9. The method of claim 7, wherein the marker is aligned with a centerline of the side aperture.

10. The method of claim 7, wherein the marker extends along a circumferential portion of the stent such that an angular orientation and a rotational orientation of the stent may be determined.

11. The method of claim 10, wherein the marker is a first marker and the stent includes a second marker, wherein the inserting of (a) comprises:

- (i) aligning the second marker with the first branch; and
- (ii) positioning the stent so that it extends into the first branch.

12. The method of claim 11, wherein the aligning of (b) comprises:

- (i) determining the position of the stent based on the orientation of the first marker and the second marker so as to effectively align the side aperture with the second branch.

13. A method of supporting a wall of a left coronary artery near a junction, the junction comprising a main branch joining a first branch and a second branch, the main branch feeding the first and second branch, the method comprising:

- (a) positioning a stent with a side aperture in the junction of the left coronary artery; and
- (b) expanding the stent so as to support the wall of the main branch and the first branch, whereby the side aperture allows the main branch to continue to feed both the first and the second branch.

14. The method of claim 13, wherein the positioning in (a) comprises:

- (i) inserting a guide wire into the coronary; and
- (ii) inserting a balloon over the guide wire into the bifurcation of the coronary, the stent positioned on the outside of the balloon.

15. The method of claim 14, wherein the expanding in (b) comprises:

- (i) expanding the balloon.

16. The method of claim 13, wherein the expanding in (b) comprises:
  - (i) allowing the stent to self-expand.
  
17. The method of claim 13, wherein the stent includes a marker, the marker being aligned with the side aperture, wherein the positioning in (a) comprises:
  - (i) inserting a portion of the stent in the first branch; and
  - (ii) aligning the marker with the second branch.
  
18. The method of claim 17, wherein the marker extends along a radial portion of the stent and the aligning in (ii) comprises:
  - (1) determining the angular orientation of the stent with the marker; and
  - (2) adjusting the angular orientation of the stent so as to effectively align the side aperture with the second branch.
  
19. The method of claim 17, wherein the second marker extends along a radial portion of the stent and the aligning in (ii) comprises:
  - (1) determining the rotational orientation of the stent with the second marker; and
  - (2) adjusting the rotational orientation of the stent so as to align the side aperture with the second branch.
  
20. The method of claim 13, wherein the stent is a first stent, the method further comprising:
  - (c) positioning a second stent in the side aperture of the first stent; and
  - (d) expanding the second stent, whereby the first and second stent form a Y shaped support structure.
  
21. The method of claim 13, wherein the stent is a first stent and includes a proximal end and a distal end, the method further comprising:
  - (c) positioning a second stent in the coronary so that a portion of the second stent overlaps with the proximal end of the first stent; and
  - (d) expanding the second stent, whereby the first and second stent form an elongated support structure.

22. A system for use in supporting a blood vessel wall, comprising:  
an angioplasty balloon;  
an expandable stent mounted on the balloon, the stent including a longitudinal axis, a circumference, a distal end and a proximal end;  
a side aperture in the stent; and  
a marker aligned with the side aperture.
23. The system of claim 22, wherein the marker is aligned with a center of the side aperture.
24. The system of 22, wherein the stent is a mesh type design and the stent is coated with an anti-neointimal proliferation agent.
25. The system of 22, wherein the balloon is non-compliant.
26. The system of claim 22, wherein the marker is positioned along a portion of the circumference of the stent.

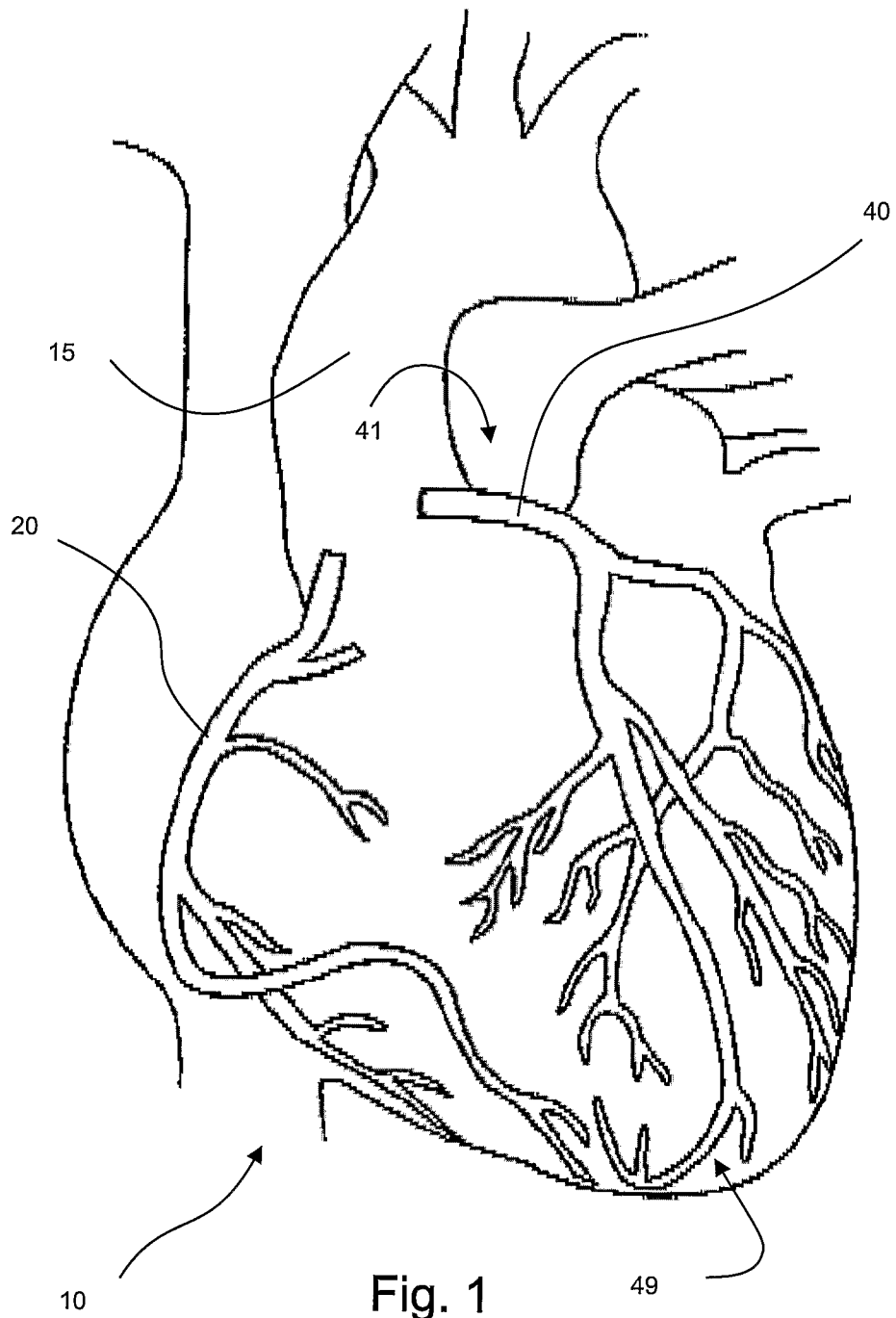

Fig. 1

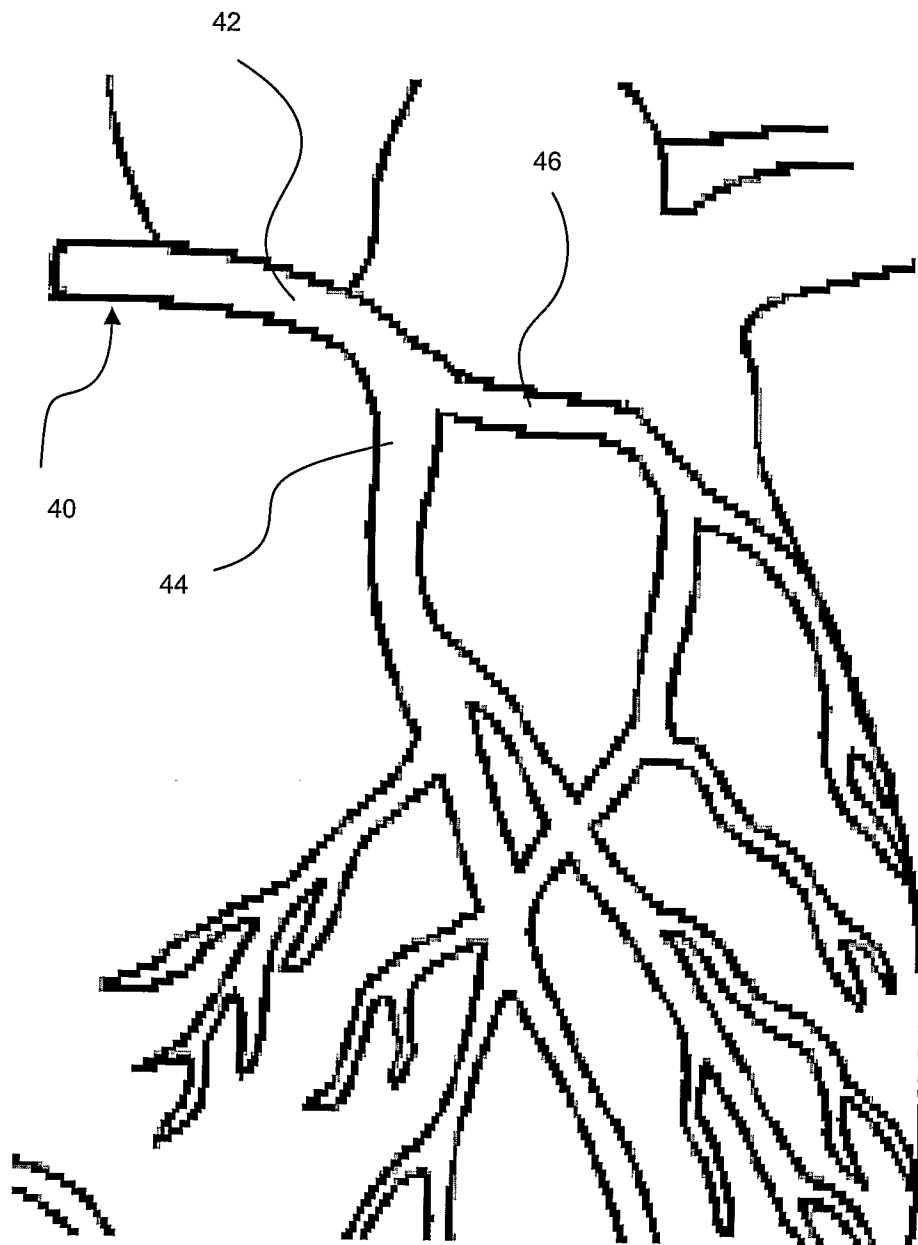

Fig. 2

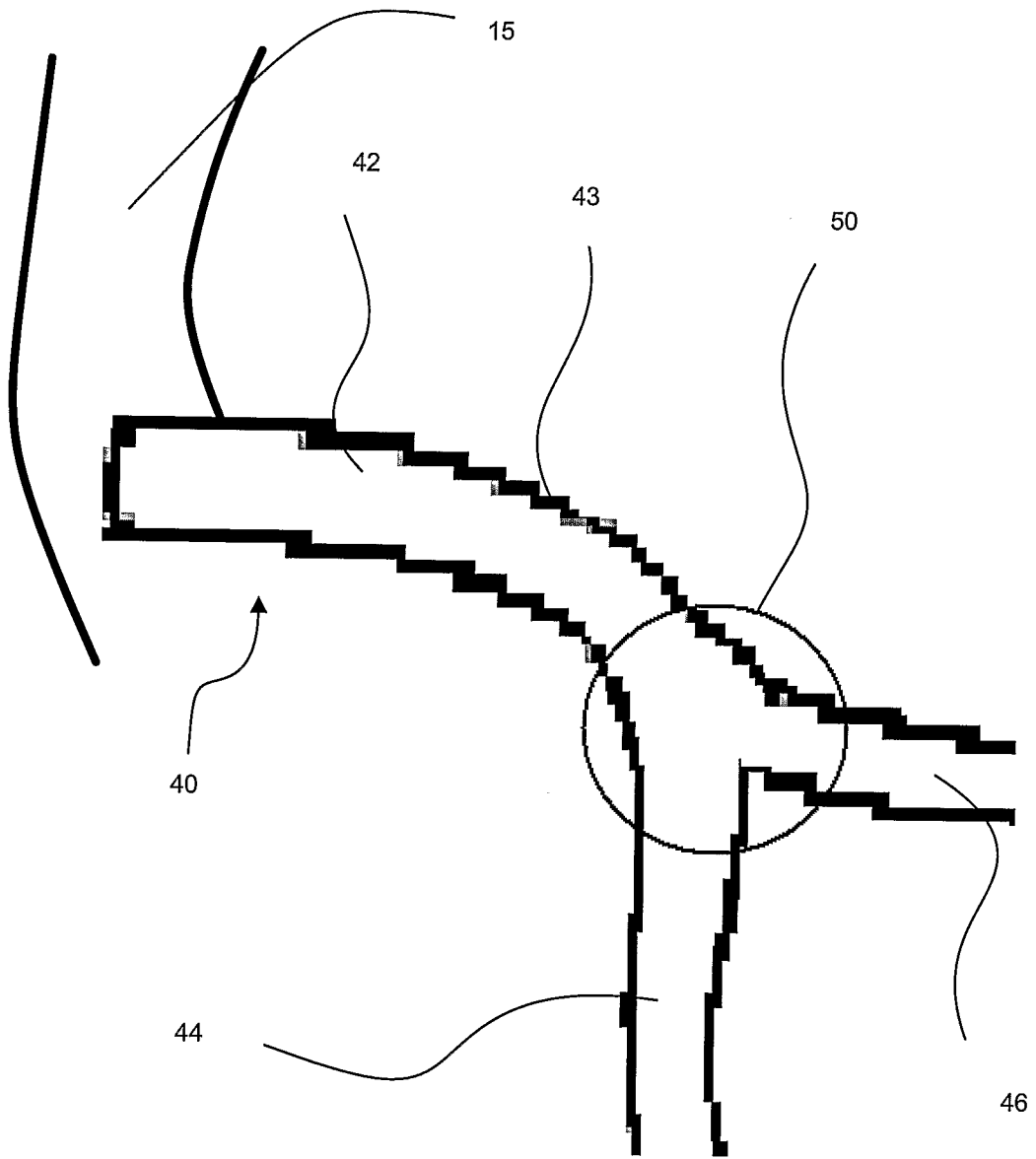

Fig. 3

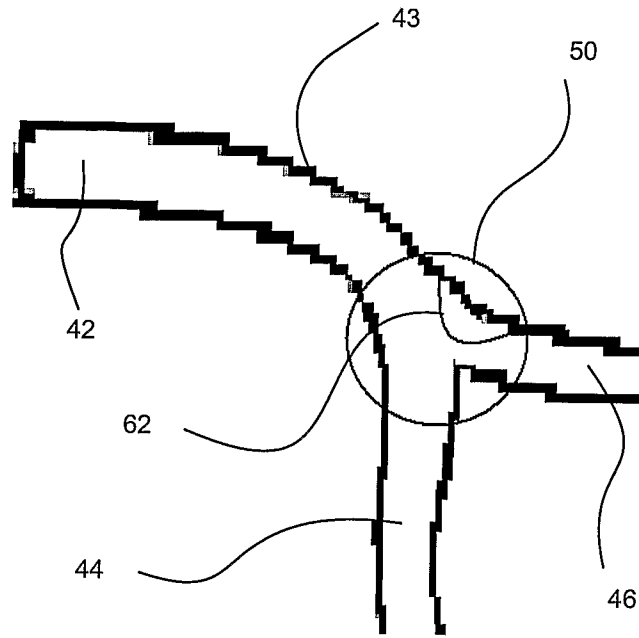

Fig. 4

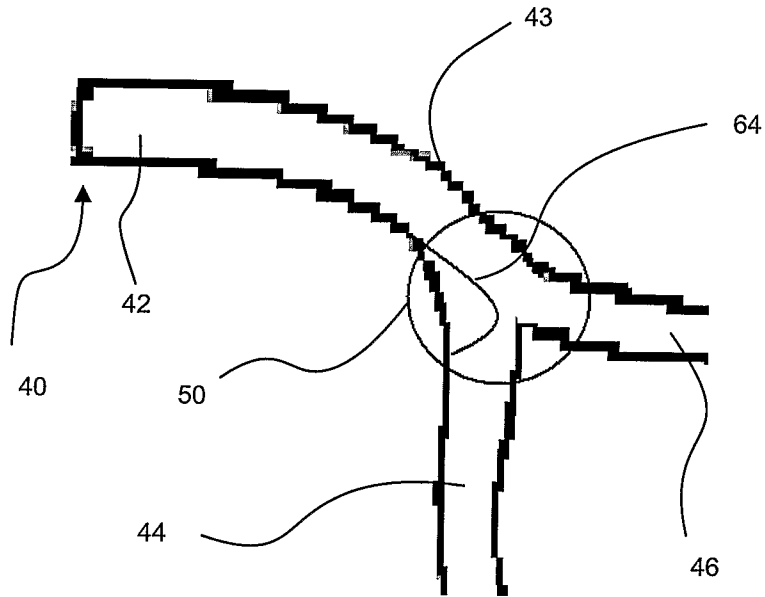

Fig. 5

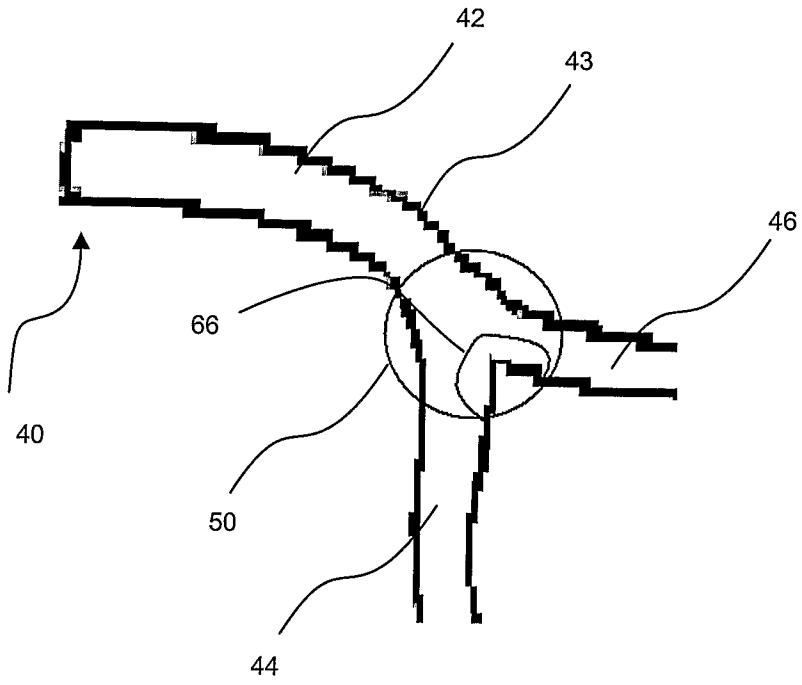

Fig. 6a

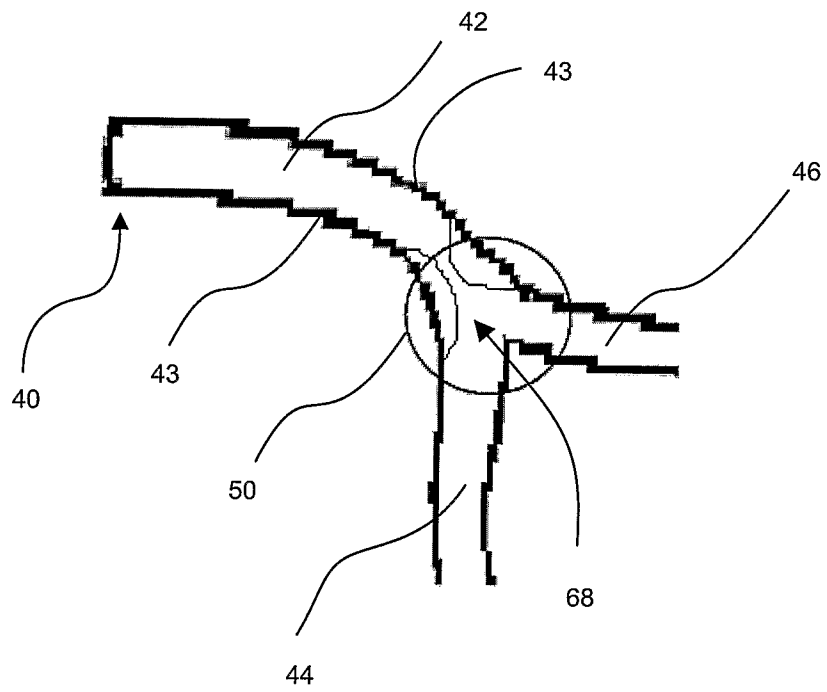

Fig. 6b

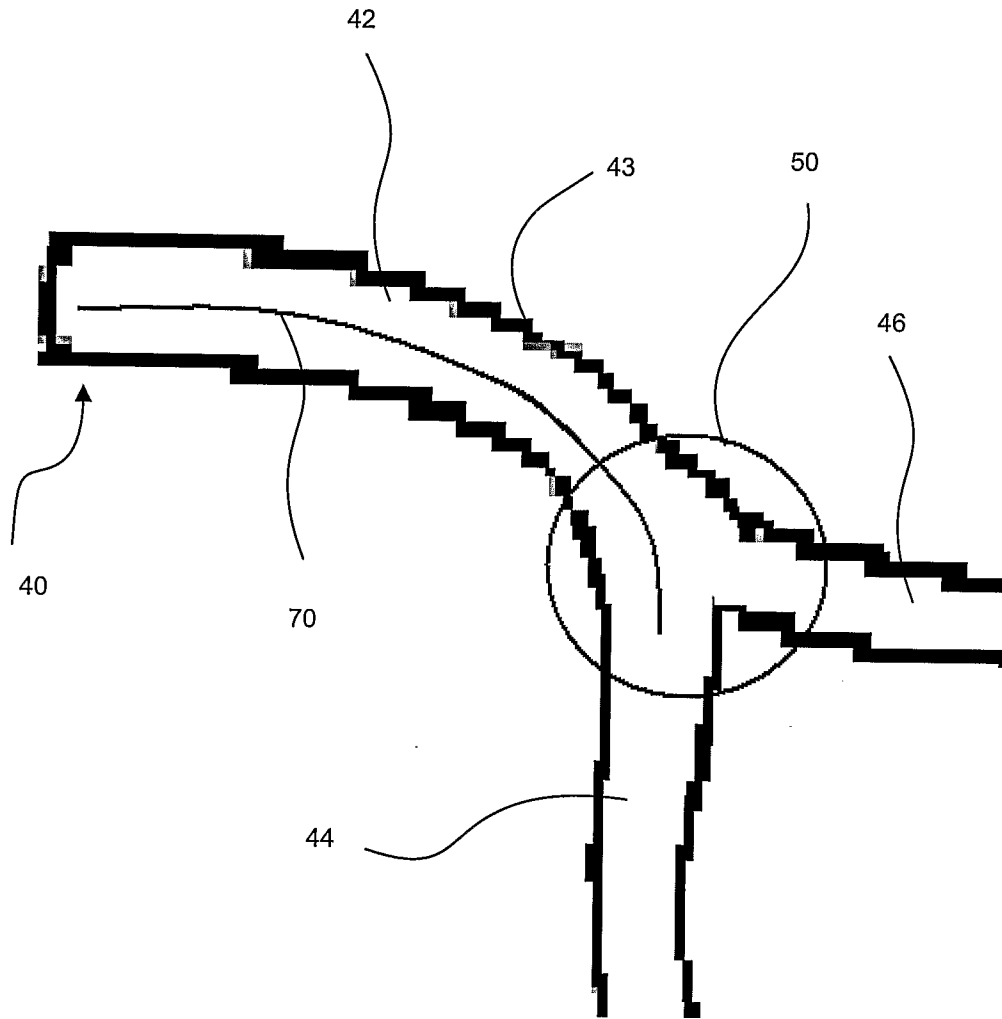

Fig. 7

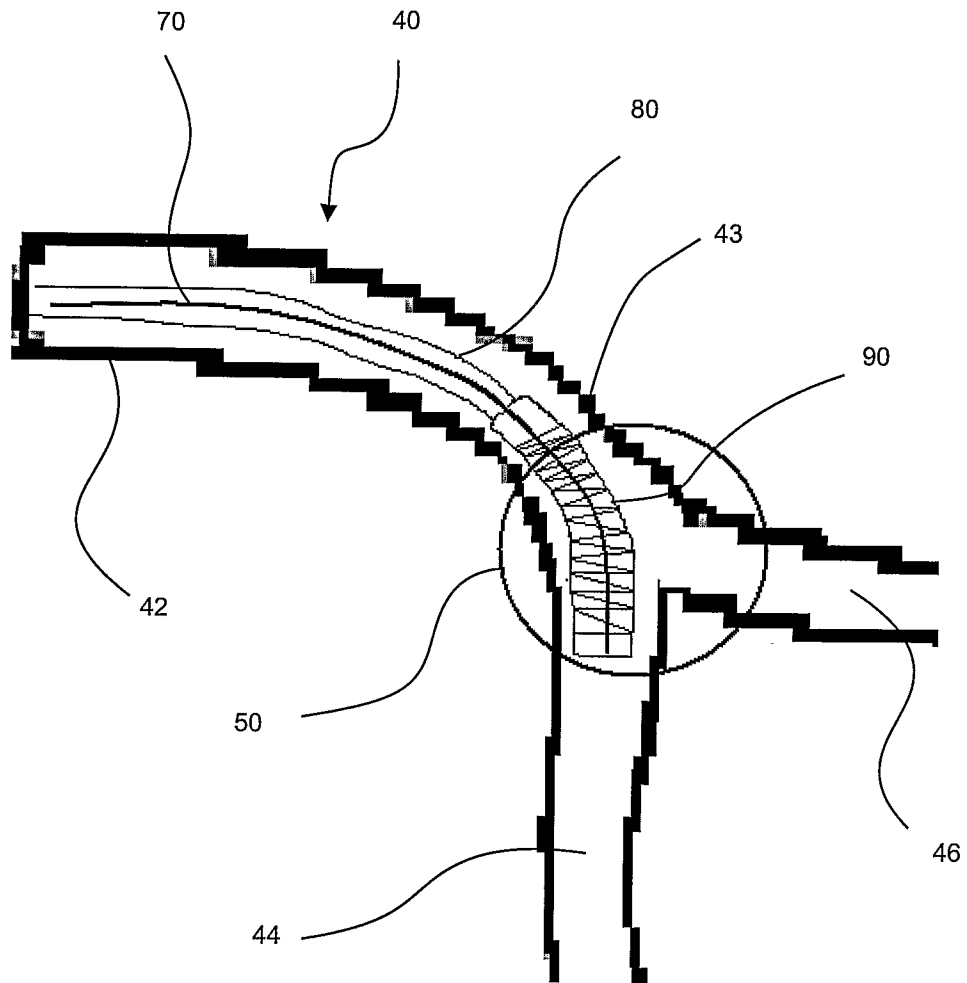
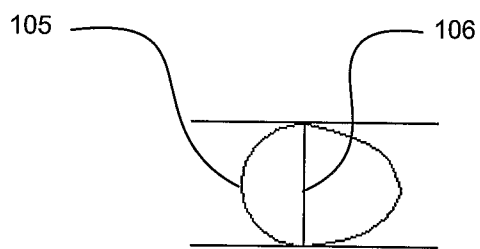
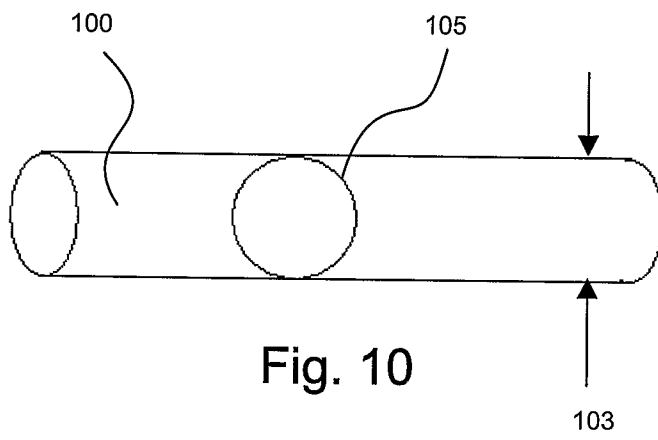
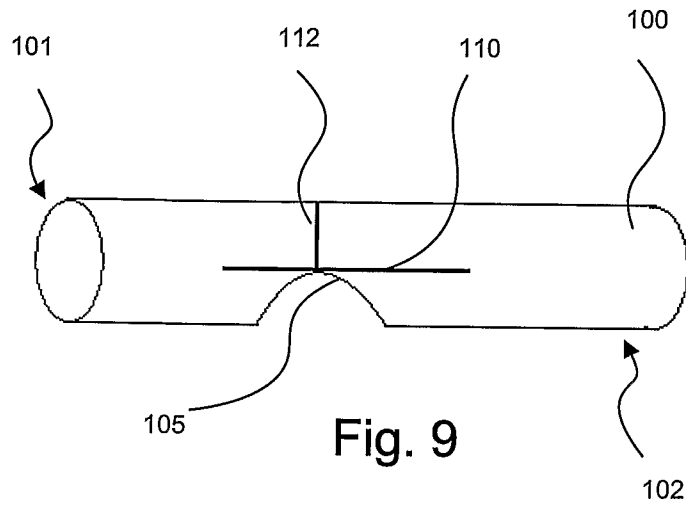

Fig. 8



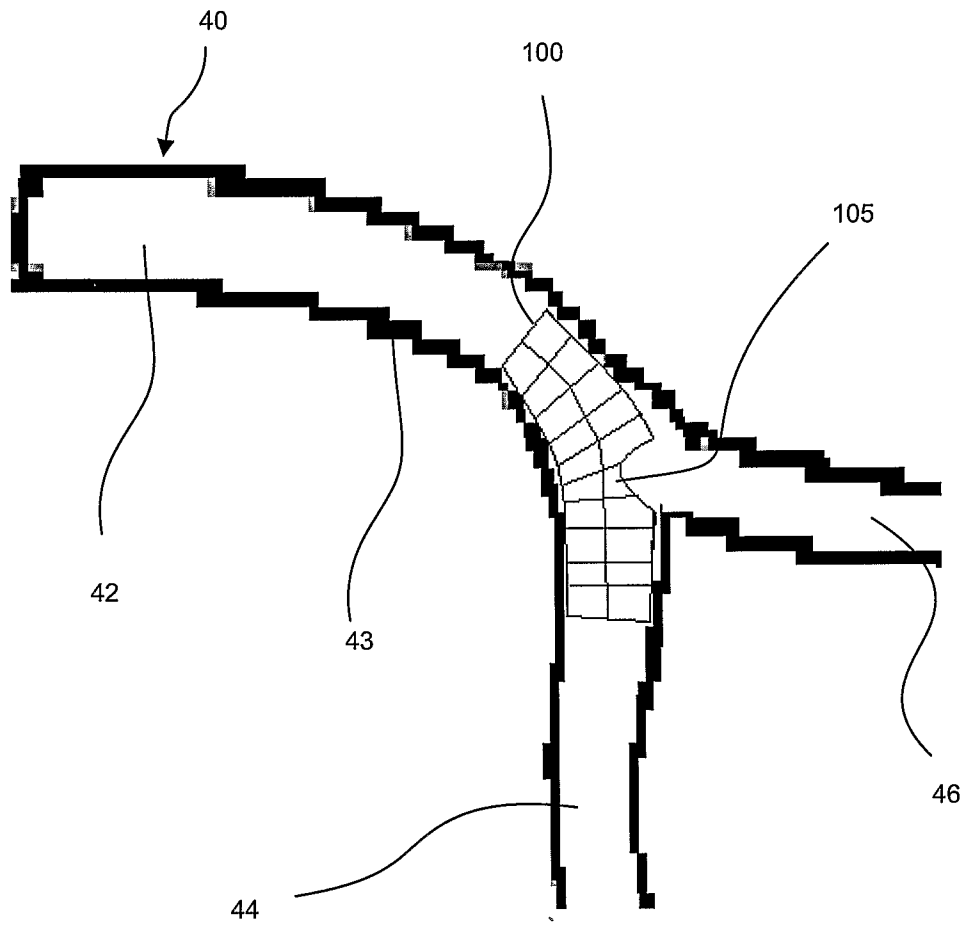

Fig. 12

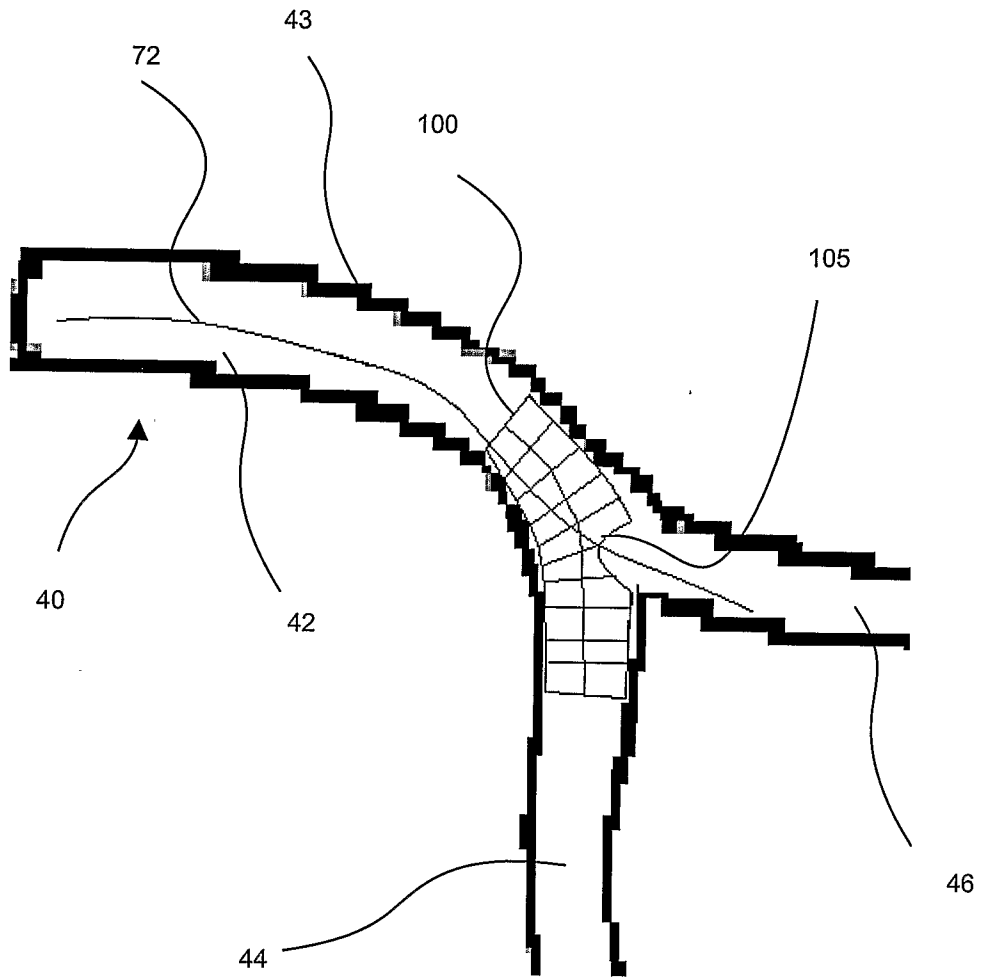

Fig. 13

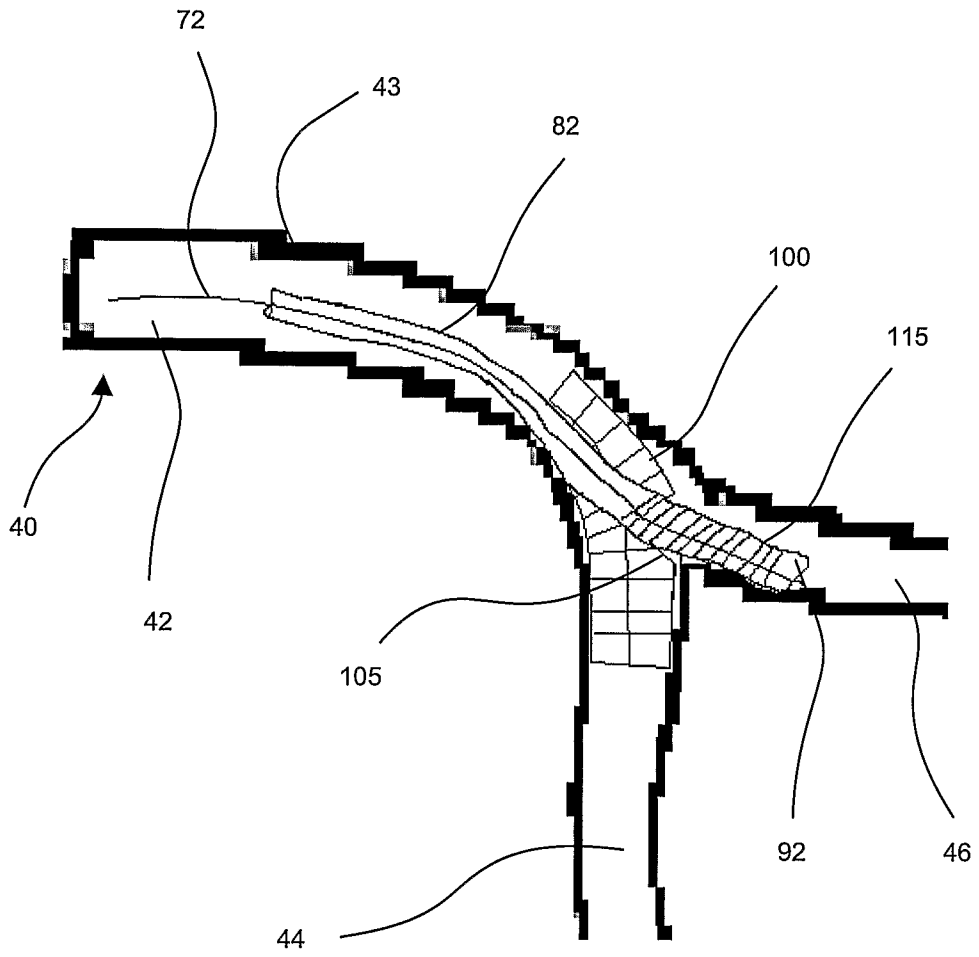

Fig. 14

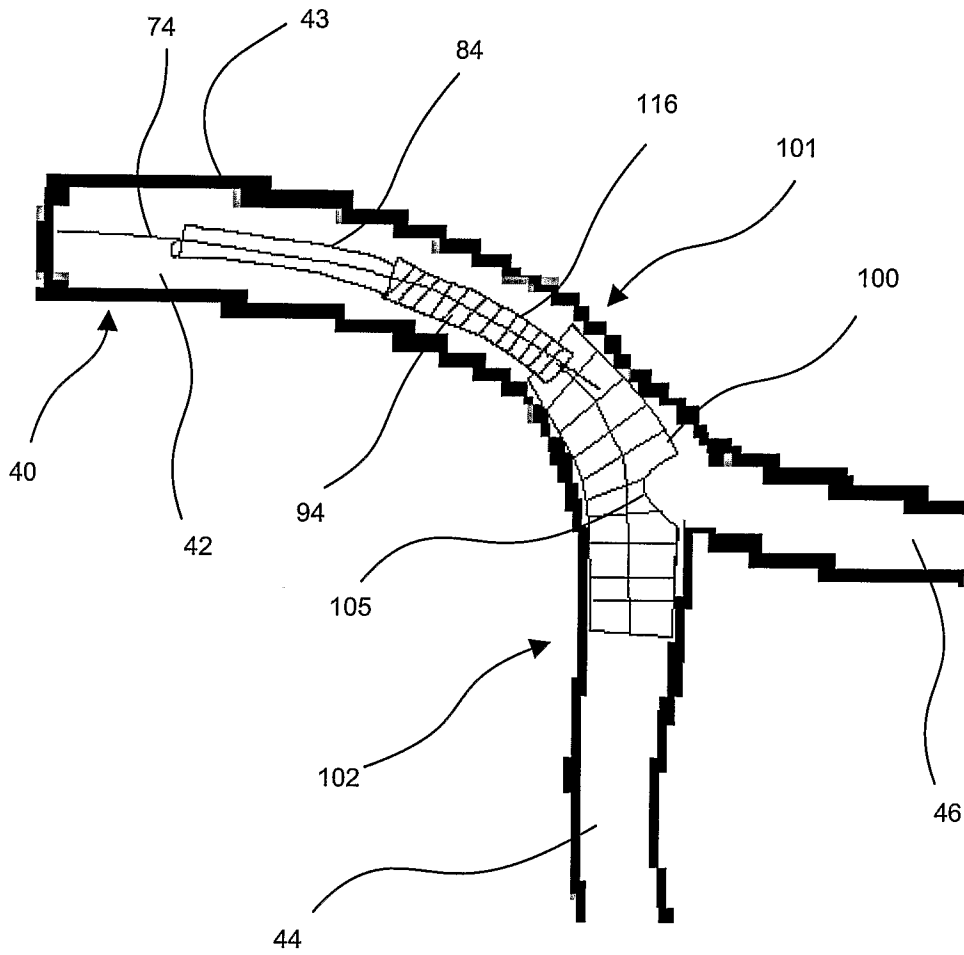

Fig. 15

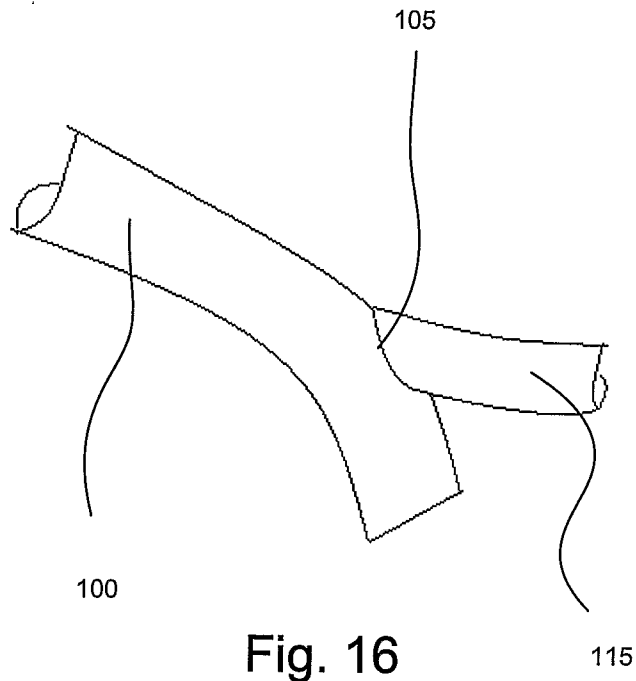

Fig. 16

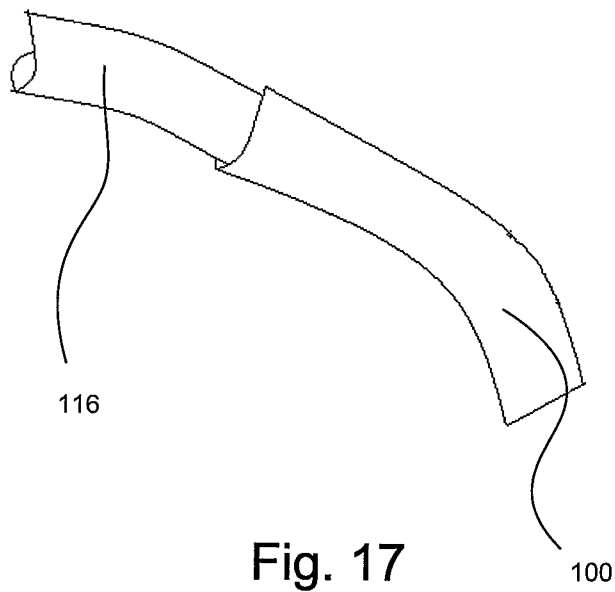

Fig. 17

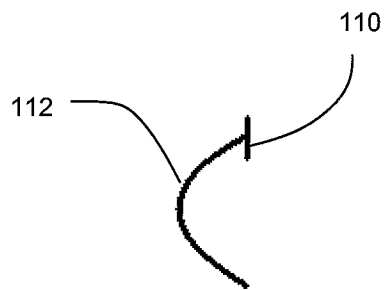
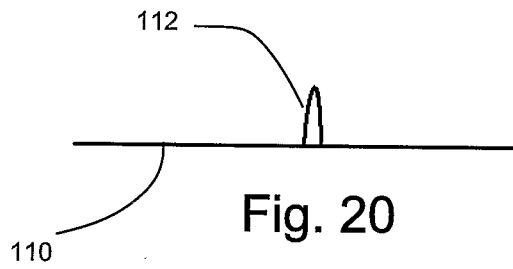
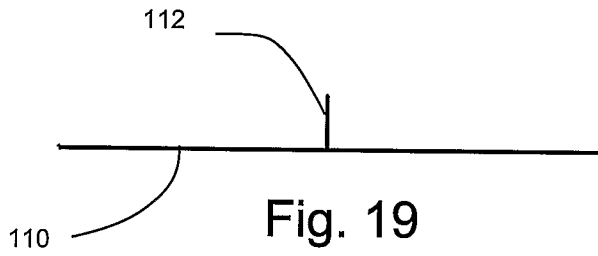
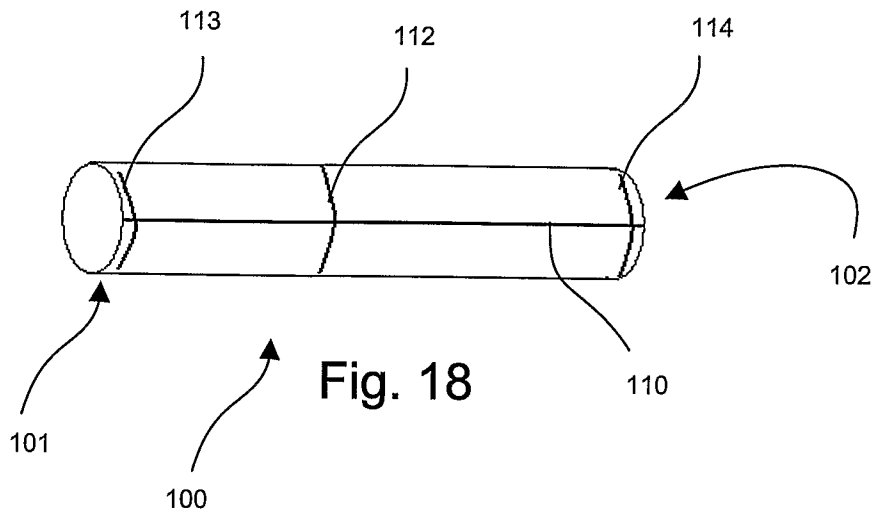

Fig. 21

