

(19) World Intellectual Property Organization  
International Bureau



(43) International Publication Date  
20 May 2010 (20.05.2010)

(10) International Publication Number  
**WO 2010/057208 A1**

(51) International Patent Classification:  
A61M 1/00 (2006.01)

(21) International Application Number:  
PCT/US2009/064846

(22) International Filing Date:  
17 November 2009 (17.11.2009)

(25) Filing Language: English

(26) Publication Language: English

(30) Priority Data:  
61/115,126 17 November 2008 (17.11.2008) US

(71) Applicant (for all designated States except US): **C. R. BARD, INC.** [US/US]; 730 Central Avenue, Murray Hill, NJ 07974 (US).

(72) Inventor; and

(75) Inventor/Applicant (for US only): **NISHTALA, Vasu** [US/US]; 2269 Bright Water Drive, Snellville, GA 30078 (US).

(74) Agent: **WIGHT, Todd, W.**; Rutan & Tucker LLP, 611 Anton Boulevard, Suite 1400, Costa Mesa, CA 92626 (US).

(81) Designated States (unless otherwise indicated, for every kind of national protection available): AE, AG, AL, AM,

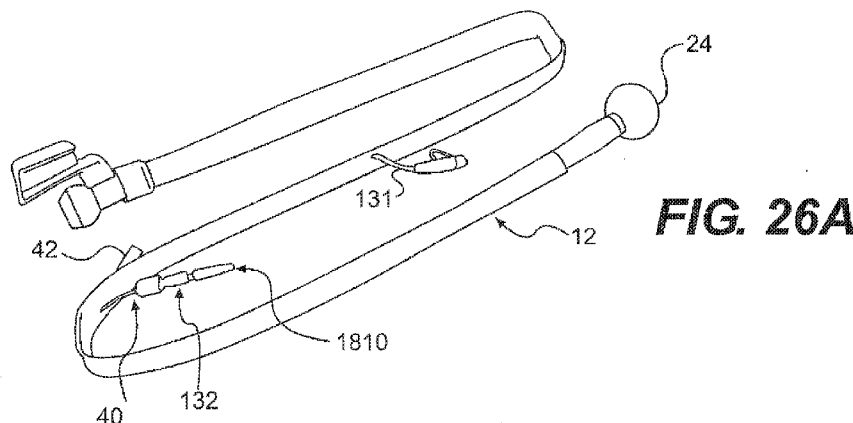
AO, AT, AU, AZ, BA, BB, BG, BH, BR, BW, BY, BZ, CA, CH, CL, CN, CO, CR, CU, CZ, DE, DK, DM, DO, DZ, EC, EE, EG, ES, FI, GB, GD, GE, GH, GM, GT, HN, HR, HU, ID, IL, IN, IS, JP, KE, KG, KM, KN, KP, KR, KZ, LA, LC, LK, LR, LS, LT, LU, LY, MA, MD, ME, MG, MK, MN, MW, MX, MY, MZ, NA, NG, NI, NO, NZ, OM, PE, PG, PH, PL, PT, RO, RS, RU, SC, SD, SE, SG, SK, SL, SM, ST, SV, SY, TJ, TM, TN, TR, TT, TZ, UA, UG, US, UZ, VC, VN, ZA, ZM, ZW.

(84) Designated States (unless otherwise indicated, for every kind of regional protection available): ARIPO (BW, GH, GM, KE, LS, MW, MZ, NA, SD, SL, SZ, TZ, UG, ZM, ZW), Eurasian (AM, AZ, BY, KG, KZ, MD, RU, TJ, TM), European (AT, BE, BG, CH, CY, CZ, DE, DK, EE, ES, FI, FR, GB, GR, HR, HU, IE, IS, IT, LT, LU, LV, MC, MK, MT, NL, NO, PL, PT, RO, SE, SI, SK, SM, TR), OAPI (BF, BJ, CF, CG, CI, CM, GA, GN, GQ, GW, ML, MR, NE, SN, TD, TG).

Published:

- with international search report (Art. 21(3))
- with information concerning one or more priority claims considered void (Rule 26bis.2(d))

(54) Title: WASTE MANAGEMENT SYSTEM



(57) Abstract: A waste management system includes a waste transport device and a waste collection device. The waste management system may include a securement device for maintaining the position of the waste transport device following insertion. The waste transport device may include a modular medication delivery apparatus with a disposable delivery device for delivering medication to the patient following insertion of the waste transport device.

WO 2010/057208 A1

## WASTE MANAGEMENT SYSTEM

### PRIORITY

[0001] This application is a continuation-in-part of International Application No. PCT/US2008/070781, filed July 22, 2008, and claims the benefit of priority to U.S. Provisional Patent Application No. 61/115,126, filed November 17, 2008, each of which is incorporated by reference into this application as if fully set forth herein.

### BACKGROUND

[0002] Waste management systems are important in the healthcare field, particularly for patients that are unable to care for themselves. Such patients may suffer from incontinent diarrhea or like maladies and, due to their condition (e.g., severe burns, surgical incisions, etc.), may be susceptible to infections should the fecal matter come in contact with an open wound, burn, surgical site, etc. Moreover, healthcare professionals that come in contact with the fecal matter while attending to the patient may be susceptible to disease and/or the spreading thereof. Thus, a suitable waste management system, at minimum, substantially contains fecal matter within a closed system so as to avoid, for example, substantial skin breakdown, infection risk, cross-contamination of pathogens, problematic patient clean-up, patient discomfort, etc. While fecal management systems are described in the art, many known issues remain unsolved or unaddressed.

[0003] The following references relate to fecal management systems or components thereof: U.S. Patent No. 5,569,216 to Kim; U.S. Patent No. 6,527,755 to Salama; U.S. Patent No. 7,147,627 to Kim et al.; U.S. Patent Application Publication No. 2005/0054996 to Gregory; U.S. Patent Application Publication No. 2005/0137526 to Machado et al.; U.S. Patent Application Publication No. 2006/0189951 to Kim et al.; U.S. Patent Application Publication No. 2006/0271087 to Von Dyck et al.; U.S. Patent Application Publication No. 2007/0049878 to Kim et al.; and U.S. Patent Application Publication No. 2007/0149922 to Schneider et al., each of which is incorporated by reference in its entirety into this application.

[0004] Applicants have recognized that it would be desirable to provide a waste management system that is robust, comfortable for the patient, eliminates known issues and has features that facilitate its use, embodiments of which are described herein.

## BRIEF SUMMARY

[0005] Accordingly, a waste management system is described herein, the system including a waste transport device and a waste collection device. The waste transport device may include a first connector member configured for releasable connection to a second connector member on the waste collection device. The system may also include an insertion device to facilitate insertion of the waste transport device into the rectum of a patient.

[0006] In one embodiment, a waste management system includes a waste transport device, including a collection member with a distal end opening having a first cross-sectional area and a proximal end opening having a second cross-sectional area less than the first cross-sectional area, a retention cuff disposed about an outer surface of the collection member, and a waste collection device.

[0007] In another embodiment, a waste transport device includes a distal section defining a distal end opening having a first cross-sectional area and a proximal end opening having a second cross-sectional area less than the first cross-sectional area, the distal section including an inflatable retention cuff, a proximal section including a flush lumen, a connector coupled to a proximal end of the proximal section, and an intermediate section connecting the proximal section to the distal section, the intermediate section including a transitioning cross-sectional shape from a proximal end to a distal end. In another embodiment, a waste transport device includes a collection member including a lumen connecting a distal end opening to a proximal end opening and a retention cuff disposed about an outer surface of the collection member, the retention cuff including a pain relief drug.

[0008] In one embodiment, a method of managing the fecal material of a patient, includes inserting a distal section of a waste transport system in a collapsed configuration into a patient's rectum, the distal section in an expanded configuration defining a distal end opening having a first cross-sectional area and a proximal end opening having a second cross-sectional area less than the first cross-sectional area, the distal section including an inflatable retention cuff, removing the insertion device from the waste transport system, and inflating the retention cuff to a first inflated configuration.

[0009] In another embodiment, a method of connecting a waste transport device to a waste collection device includes associating a first connector coupled to the waste transport device with a second connector coupled to the waste collection device by aligning an aperture

of the first connector with an aperture of the second connector and pressing an end of one or more locking arms of the first connector into slots of the second connector, and sliding the first and second connectors to align the apertures with a central lumen of the waste transport device and an opening of the waste collection device.

**[0010]** In another embodiment, a waste management system includes a waste transport device, including a collection member with a distal end opening having a first cross-sectional area and a proximal end opening having a second cross-sectional area less than the first cross-sectional area, a lumen fluidly connecting the distal end opening to the proximal end opening, a retention cuff disposed about an outer surface of the collection member, and a securement device, including means for attaching the securement device to the waste transport device.

**[0011]** In another embodiment, a waste management system includes a waste transport device, including a collection member with a distal end opening and a proximal end opening, a lumen fluidly connecting the distal end opening to the proximal end opening, a retention cuff disposed about an outer surface of the collection member, and a medication delivery apparatus configured to deliver a therapeutic agent through the waste transport device, including an interface port having an opening sealed by a septum.

**[0012]** These and other embodiments, features and advantages will become more apparent to those skilled in the art when taken with reference to the following more detailed description in conjunction with the accompanying drawings that are first briefly described.

#### BRIEF DESCRIPTION OF THE DRAWINGS

**[0013]** FIG. 1A is a perspective view of a waste management system.

**[0014]** FIG. 1B is a perspective view of the proximal end of the system of FIG. 1 with the waste transport device separated from the waste collection device.

**[0015]** FIG. 2A is a longitudinal cross-sectional perspective view of a distal section of a waste transport device.

**[0016]** FIG. 2B is a longitudinal cross-sectional side view of a distal end of FIG. 2A.

**[0017]** FIG. 2C is a perspective view of one embodiment of a retention cuff for a waste transport device.

[0018] FIG. 2D is a perspective view of another embodiment of a retention cuff for a waste transport device.

[0019] FIG. 2E is a perspective view of yet another embodiment of a retention cuff for a waste transport device.

[0020] FIG. 2F is a perspective view of FIG. 2B.

[0021] FIG. 2G is a top view of FIG. 2B.

[0022] FIG. 2H is a side view of FIG. 2B.

[0023] FIG. 2I is an axial cross-sectional view of a section of a waste transport device.

[0024] FIGS. 3A-D illustrate stages of deflation and folding of a retention cuff of a waste transport device.

[0025] FIG. 4A-B are perspective views of a waste transport device with a proximal cuff.

[0026] FIG. 4C is one embodiment of an inflatable retention cuff.

[0027] FIGS. 5A-D are perspective views of different embodiments of a collection member.

[0028] FIG. 6 is a cross-sectional view of one embodiment of a single piece collection member and sphincter section.

[0029] FIGS. 7A-B are perspective views of another embodiment of a single piece collection member and sphincter section.

[0030] FIG. 7C is a perspective view of one embodiment of a retention cuff.

[0031] FIG. 7D is a perspective view of one embodiment of a waste management system.

[0032] FIGS. 7E-G are cross-sectional views of different regions of the waste management system of FIG. 7D.

[0033] FIG. 8A is a perspective view of another embodiment of a waste management system.

[0034] FIG. 8B is a partial view of a single piece collection member and sphincter section of the waste management system of FIG. 8A.

[0035] FIG. 8C is a cross-sectional view of the extracorporeal section of the waste management system of FIG. 8A.

[0036] FIG. 8D is a cross-sectional view of the waste transport device of the waste management system of FIG. 8A.

[0037] FIG. 9A is a perspective view of one embodiment of a waste management system with a valved connection system.

[0038] FIGS. 9B-D are enlarged views of the connection system of FIG. 9A at different stages of connection between the waste transport device and waste collection device.

[0039] FIGS. 10A-B are perspective views of another embodiment of a connection system for a waste management system.

[0040] FIGS. 11A-D are perspective views of another embodiment of a connection system for a waste management system.

[0041] FIG. 12 is a perspective view of yet another embodiment of a connection system for a waste management system.

[0042] FIGS. 13A-C are perspective view of another embodiment of a connection system for a waste management system.

[0043] FIGS. 14A-D are perspective views of still another embodiment of a connection system for a waste management system.

[0044] FIGS. 15A-D are perspective views of one embodiment of an insertion device for a waste management system.

[0045] FIGS. 16A-C are perspective views of another embodiment of an insertion device for a waste management system.

[0046] FIGS. 17A-D are perspective views of another embodiment of an insertion device for a waste management system.

[0047] FIGS. 18A-C are perspective views of yet another embodiment of an insertion device for a waste management system.

[0048] FIGS. 19A-B are perspective views of still another embodiment of an insertion device for a waste management system.

[0049] FIGS. 20A-C are perspective views of another embodiment of an insertion device for a waste management system.

[0050] FIG. 21 is a perspective view of another embodiment of an insertion device for a waste management system.

[0051] FIG. 22 is a perspective view of a securement device for a waste management system.

[0052] FIGS. 23A-D are perspective views of the securement device of FIG. 22 positioned onto a waste transport device.

[0053] FIGS. 24A-D are perspective views of a medication delivery apparatus with an independent disposable delivery device.

[0054] FIG. 25 is a cross-sectional view of another embodiment of a medication delivery apparatus with a dedicated drug delivery lumen.

[0055] FIGS. 26A-B are perspective views of a pressure gauge for a waste management system.

[0056] FIG. 27 is another embodiment of a pressure gauge for a waste management system.

[0057] FIGS. 28A-28C illustrate one embodiment of a sheathing apparatus to facilitate insertion of a waste management system.

[0058] FIG. 29 illustrates one embodiment of a bacterial testing apparatus for a waste management system.

## DESCRIPTION

**[0059]** The following description should be read with reference to the drawings, in which like elements in different drawings are identically numbered. The drawings, which are not necessarily to scale, depict selected embodiments and are not intended to limit the scope of the invention. The description illustrates by way of example, not by way of limitation, the principles of the invention. This description will clearly enable one skilled in the art to make and use the invention, and describes several embodiments, adaptations, variations, alternatives and uses of the invention, including what is presently believed to be the best mode of carrying out the invention.

**[0060]** As used herein, the terms “about” or “approximately” for any numerical values or ranges indicate a suitable dimensional tolerance that allows the part or collection of components to function for its intended purpose as described herein. Also, as used herein, the terms “patient”, “host” and “subject” refer to any human or animal subject and are not intended to limit the systems or methods to human use, although use of the subject invention in a human patient represents a preferred embodiment.

**[0061]** The waste management system described herein generally includes a waste transport device and a waste collection device. The waste transport device includes a distal end section, referred to herein as “the rectal section,” configured for disposition in a patient’s rectum to begin transport of fecal material from a patient to a waste collection device; a section proximal of the rectal section, referred to herein as “the sphincter section,” configured for disposition in a patient’s anal canal; and a section proximal of the sphincter section, referred to herein as “the extracorporeal section,” having a majority of its length outside of the patient. The proximal end of the waste transport device is configured to connect to a waste collection device, including a collection container. In certain embodiments, the waste management system includes a connection system for selective coupling of the waste transport device to the waste collection device and/or an insertion device to facilitate insertion of the waste transport device into a patient. Embodiments of these and other features of a waste management system are described herein.

**[0062]** With reference to FIG. 1A, a waste management system 10 includes a waste transport device, including a generally tubular body (e.g., catheter) 12, having a distal end 14 and a proximal end 16, and a waste collection device, including a collection container 30. Positioned at the distal end 14 of the body 12 is a rectal section 18, including a collection



member 32 and a retention cuff 24 disposed about an outer surface of the collection member 32 (FIG. 2). Proximal of the rectal section is a sphincter section 20, particularly adapted for disposition in the anal region of a patient, and an extracorporeal section 22 generally positioned outside of the patient's body when the system is in use (although a portion thereof may be inside). In one embodiment, the collection member 32, sphincter section 20 and extracorporeal section 22 are made of a material (e.g., silicone) with the same durometer (e.g., about 50 Shore A), while the retention cuff 24 is made of a material (e.g., silicone) with a different durometer (e.g., about 35 Shore A). In another embodiment, each of the aforementioned components are made of a material (e.g., silicone) with the same durometer (e.g., about 50 Shore A). A body connector 26 is coupled to a proximal end of the extracorporeal section 22 and is configured for quick, secure coupling to a collection container connector 28 to place the body 12 in fluid communication with a collection container 30. Various examples of connector embodiments are described in detail below. The body 12 generally has a plurality of lumens extending along at least a portion of its length, including, for example, a central lumen 34 for passage of fecal material from the patient to the collection container 30, an inflation lumen 36, a sampling lumen 38, and a flush lumen 44, each of which is discussed in detail below.

**[0063]** With reference to the rectal section 18 of the body 12, shown in FIGS. 2A-2B, the collection member 32 has a distal opening 31 that, when positioned for normal use, opens into the rectum of a patient, and a proximal opening 33 that connects to the sphincter section 20. In one embodiment, the proximal opening 33 has a cross-sectional area that is less than a cross-sectional area of the distal opening. For example, the proximal opening 33 may have an inner diameter less than the inner diameter of the distal opening 31. Such a configuration imparts to the collection member 32 a tapered shape (e.g., a funnel), which is believed to aid in the flow of waste material from the patient into the body 12. It is noted that the tapered shape according to one embodiment is a frusto-conical shape. In one embodiment, the collection member 32 is formed from one or more materials having a durometer sufficiently hard to prevent premature closure of the distal opening 31, thereby permitting safe passage of fecal material from the patient regardless of forces acting on the collection member 32. For example, the collection member may be made from a material selected from polyurethane, silicone rubber, natural rubber latex, synthetic rubber, guayule rubber, 80 SH polydimethylsiloxane, fumed silica, polyvinyl chloride (PVC), and combinations thereof. In one embodiment, the collection member 32 includes an annular ring disposed on the distal

end thereof, the annular ring including a plurality of openings about its perimeter, which are connected to lumens through a wall of the collection member that may connect to one or more lumens disposed in the sphincter section and/or extracorporeal section. For example, the lumens through the wall of the collection member could extend through the sphincter section, all of which could connect to the sampling lumen 38.

**[0064]** In one embodiment, the rectal section 18 includes a split valve/baffle configured to control the type of fluid permitted to pass therethrough. For example, the baffle in one embodiment is configured such that an infusion of medication into the rectum will not open (e.g., flow through) the baffle, but a greater volume of fecal material will open (e.g., flow through) the baffle. In one embodiment, the baffle includes a plurality of discs extending alternately from different sides of a passage of the rectal section 18 (e.g., the collection member 32) such that the area open for fluid flow is spaced apart therealong. Thus, the medication intended for the patient will remain for a longer period within the rectum. In another embodiment, a duckbill valve is included in the rectal section 18 to control fluid flow therethrough.

**[0065]** In the embodiment shown in FIGS. 2A-2B, the retention cuff 24 is disposed about and attached to an outer surface of the collection member 32 and includes an inflatable balloon (e.g., conventional or non-conventional). In some embodiments, the balloon 24 includes a drug, such as a pain relief drug (e.g., lidocaine). The drug may be coated on a surface of the balloon 24 and/or may be incorporated in an inflation liquid (e.g., lidocaine mixture) such that the drug gradually diffuses through a wall of the balloon 24. In one embodiment, the retention cuff 24 includes a balloon, an outer surface of which is coated with lidocaine, and which is inflated following insertion into the patient with a lidocaine or a mixture including lidocaine. Surfactants and anti-microbial lubricant coatings may also be disposed on the retention cuff. Also, a retention cuff balloon may be encased or otherwise associated with a foam to maintain the rectal section in its deployed position within the patient's rectum and to prevent leakage. The foam may include an absorbant material and/or a coating to reduce odor. In one embodiment, a relatively high viscosity foam is used to inflate the retention cuff, following introduction into the rectum.

**[0066]** FIGS. 2C-2E illustrate embodiments of the rectal section 18 with a retention cuff 24 and a collection member 32. FIG. 2C is similar to FIG. 2A, including a collection member 32 with a frusto-conical shape having a smooth continuous wall (e.g., no pleats or

divisions between the proximal and distal openings) and a retention cuff 24 that when inflated creates a shoulder 11 at the junction between the cuff 24 and the body (e.g., sphincter section 20). FIG. 2D shows a cuff 24d with a geometry that more gradually transitions to the body, the collection member 32d having a bell-shaped configuration (i.e., frusto-conical shape with a flared distal opening) with a smooth continuous wall. FIG. 2E shows cuff 24d surrounding a collection member 32e that has a trumpet-shaped configuration (i.e., a frusto-conical shape with curved sides and a flared distal opening) with a smooth continuous wall. The retention cuff in some embodiments, may also include one or more structural features as described more completely below in connection with FIGS. 5A-5D. Also, the retention cuff may have a tapered shape when inflated such that the diameter or perimeter increases from a proximal end to a distal end.

**[0067]** FIGS. 3A-3D illustrates one embodiment of a rectal section 18 with a retention cuff balloon 24, configured to provide an advantageously small profile for insertion. FIG. 3A illustrates the cuff 24 in its inflated state. FIG. 3B illustrates the beginning of deflation, showing the configuration of the cuff 24, which includes pockets 24' disposed between spaced apart raised sections 24'' about the circumference of the cuff 24. FIG. 3C illustrates further deflation of the cuff 24 as the raised areas 24'' collapse into the lumen of the rectal section 18, the cuff easily folded by bringing together the raised sections 24'', as illustrated in FIG. 3D. It is noted that any of the retention cuffs 24 described herein may have a similar configuration to provide a small profile for insertion.

**[0068]** FIGS. 4A-4B illustrate embodiments including a proximal cuff 25, shown generally in FIG. 4A. The proximal cuff 25, which can include an inflatable balloon, is mounted to the body 12 proximally from the retention cuff 24, for example, along the extracorporeal section 22. Thus, when the body 12 is properly inserted, the proximal cuff 25 may be located between the patient's buttocks. The proximal cuff 25 is adapted to prevent upward migration of the retention cuff 24 when inserted and deployed in a patient's rectum and may optionally include anti-odor, moisturizer and/or lubricant coatings. In one embodiment, the proximal cuff has the form of an umbrella, cone, basin, etc. with the wide part facing the retention cuff in order to capture material that may leak from around the body. The cuff in such an embodiment may be made of a soft, absorbent material and is configured to be removable from the body in order to replace when necessary, or alternatively may be made of a material that is easily cleaned, such as, for example, a soft plastic material.

[0069] FIG. 4B illustrates a variation of a distal section of a body 12, which includes a retention cuff 24 and a proximal cuff 25 with a tension member 27 disposed in the wall of the body (e.g., along a portion of the sphincter section 20) between the cuffs 24, 25. The tension member 27 may include one or more elongated members embedded in the wall of the sphincter section and/or coupled to an inner or outer wall thereof. The tension member may include spaced apart longitudinally oriented members, circumferentially oriented members, helically arranged members, combinations thereof, etc. According to one embodiment, however, the tension member 27 is a helical coil made of shape memory material (e.g., Nitinol). Adjacent the proximal cuff 25, a sphincter section 29 free of the tension member is provided to prevent loss of sphincter tone as discussed above.

[0070] The tension member 27 has a collapsed configuration with a collapsed perimeter and an expanded configuration with an expanded perimeter greater than the collapsed perimeter. In one embodiment, at least a portion of the tension member 27 is disposed adjacent the retention cuff 24 such that when the retention cuff 24 is inflated, the tension member expands from the collapsed perimeter to the expanded perimeter. Following inflation of the retention cuff 24 and expansion of the tension member 27, the proximal cuff 25 is inflated. Due to the shape memory material, the tension member 27 will attempt to return to its collapsed configuration, which due to the connection to the retention cuff 24 will be resisted. This resistance provides tension between the cuffs 24, 25, which is believed to aid in the prevention of leakage and migration of the distal end of the body 12.

[0071] FIG. 4C illustrates one embodiment of an inflatable retention cuff that is adapted to occlude the distal opening 31 when activated. Occluding the lumen 34 of the body 12 may be desirable, for example, to temporarily block reflux and to retain medicants or drugs in the rectal vault. Known systems accomplish the occlusion function by including an internal balloon in the distal end of a catheter. The presence of an internal balloon may partially block the lumen of the catheter even when not inflated and/or may provide a surface for which fecal material adheres to, resulting in build-up and eventual blockage of the lumen. In the embodiment of FIG. 4C, instead of an internal balloon, retention cuff 80 includes a plurality of lobes 82 that may be expanded from a first inflated configuration, similar to the retention cuff 24 described above, to a second inflated configuration (as shown), converging to cover the distal opening 31 or otherwise block fluid from reaching the distal opening 31. The expansion from the first inflated configuration to the second inflated configuration can

be accomplished by an infusion system 84 that indicates to the user the state of the retention cuff 80 (i.e., deflated, first inflated configuration, second inflated configuration) based on a pressure reading of the cuff 80. For example, the infusion system 84 could provide a readout of a first volume (e.g., 50 mL) when the lobes 82 are in the first inflated configuration and a second volume (e.g., 150 mL) when the lobes 82 are in the second inflated configuration. In another embodiment, a sliding cuff or sleeve may be positioned proximal of the retention cuff 80, the sliding cuff including arms or surfaces configured to force the cuff 80 inward upon contact therewith such that the distal opening 31 is occluded when the sliding cuff impinges on the retention cuff. Thus, for example, after the retention cuff 80 has been inflated to the first inflated configuration, the sliding cuff is moved distally at least partially over the retention cuff 80 to occlude the opening 31. Thereafter, when it is desired to remove fecal matter from the rectum, the sliding cuff is moved proximally out of contact with the retention cuff 80 so that the distal opening 31 is no longer occluded.

**[0072]** FIGS. 5A-5D illustrate different embodiments of the collection member. FIG. 5A illustrates a collection member 60 with a plurality of spaced apart struts 62 attached at their distal end to a ring 64, which defines the distal opening 31. The three struts 62 in the embodiment shown are twisted to facilitate collapse of the retention cuff 24 for insertion and removal of the body from the patient. The proximal end of the struts 62 may be coupled to the body just proximal of the rectal section 18 (e.g., sphincter section 20) or may extend further along a length of the body (e.g., through at least a portion of the extracorporeal section 22) to provide structural support thereto. The struts 62 may be embedded in the wall of the body section(s) or may be coupled to a surface thereof. In the rectal section 18, the twisted struts 62 may, together with the retention cuff 24, define the collection member lumen. Alternatively, the collection member lumen may be defined by another member (e.g., a tapered extrusion) to which the struts 62 are attached. The struts 62 and ring 64 may be formed from a metal, polymer, or other suitable material that provides structural support to the rectal section 18, and may have a circular cross-sectional shape, rectangular cross-sectional shape, or any other geometric cross-sectional shape.

**[0073]** FIG. 5B is another embodiment of a collection member with a plurality of spaced apart struts (e.g., four), the struts 66 remaining untwisted (e.g., substantially aligned along a longitudinal axis) and attaching distally to the cuff 24 rather than a ring. Of course, a ring could also be included and/or a further member as described above in connection with

FIG. 5A. The struts 66 have an increasing cross-sectional area from the proximal end to the distal end and in the embodiment shown transition from a circular cross-sectional shape at the proximal end to an oval cross-sectional shape at the distal end. Other cross-sectional shapes are also possible, such as those described above in connection with FIG. 5A, and are within the scope of the invention. FIG. 5C is an embodiment of a collection member including a helically arranged elongate member in the form of a coil 68. The coil 68 defines a lumen along a longitudinal axis thereof and may be attached directly to the cuff 64 or an additional tapered member. In one embodiment, the elongate member forming the coil 68 is hollow and is attached directly to the sampling lumen 38 to provide access to the patient's rectum for infusion of drugs/fluids and/or extracting samples for testing. FIG. 5D is yet another embodiment of a collection member. Collection member 70 has distal sections removed to facilitate collapse of the rectal section for insertion and removal. In the embodiment illustrated, the removal of sections results in a plurality of petals 72 evenly spaced apart about the circumference of the collection member 70. It should be noted, however, that many other types of patterns, including non-uniform patterns, are also contemplated herein and within the scope of the invention.

**[0074]** With further reference to the embodiment shown in FIGS. 2A-2B, the sphincter section 20 is disposed between the collection member 32 and the extracorporeal section 22. The sphincter section 20 in one embodiment is distinct from the extracorporeal section 22 and/or the collection member 32 in that the sphincter section is configured to collapse under lower pressures to preserve the tone/strength of the sphincter when positioned in the patient for extended periods. For example, in one embodiment, the material for the collection member 32 and sphincter section 20 are the same, but the thickness of the wall of the sphincter section 20 is less than the wall of the collection member 32. In other embodiments, the material for the sphincter section 20 is different from the material for the collection member 32 (e.g., more compliant, softer durometer, etc.) In one embodiment, the sphincter section 20 is made from a material selected from polyurethane, silicone rubber, natural rubber latex, synthetic rubber, 80 SH polydimethylsiloxane, fumed silica, polyvinyl chloride (PVC), and combinations thereof.

**[0075]** The shape of the sphincter section 20 may have a cross-sectional shape that transitions from a distal end 21 to a proximal end 23, such as shown in FIGS. 2A-2B and 2F-2H. For example, the sphincter section 20 in the embodiment shown has a substantially

circular cross-sectional shape at its distal end 21 and an oval cross-sectional shape at its proximal end 23 that attaches to the extracorporeal section 22. In other words, at its proximal end 23, the sphincter section 20 has a larger diameter along a first axis (i.e. the z-axis shown in FIG. 2B), than along a second axis orthogonal to the first axis (i.e. the y-axis shown in FIG. 2B). The oval proximal end 23 of the sphincter section matches the oval distal end of the extracorporeal section 22 (FIG. 2I), which in one embodiment maintains this oval cross-sectional shape from the distal end to the proximal end. The transitional shape for the sphincter section 20 is advantageous for resisting rotational motion. That is, the sections of the system that have oval cross-sections (e.g., the sphincter section proximal end 23 and the extracorporeal distal end) are more resistant to rotation than sections with circular cross-sections (e.g., the sphincter section distal end 21 and the collection member proximal end 33). In one embodiment, the sphincter section 20 has an hourglass shape. As with the embodiment of FIGS. 2A-2B and 2F-2H, the proximal end of the sphincter section 20 may have an oval cross-sectional shape, while the distal end may have a circular cross-sectional shape. Alternatively, each of the proximal and distal ends of the sphincter section may have a circular cross-sectional shape to match circular cross-sectional shapes of the distal end of the extracorporeal section and the proximal end of the rectal section, respectively.

**[0076]** In one embodiment, the sphincter section 20 includes a sealing feature, such as a plurality of ribs arranged about the perimeter thereof. The ribs may be spaced apart and inflatable such that the ribs are deflated for insertion and inflated upon deployment. When inflated, the ribs may provide a seal and/or prevent rotational movement of the sphincter section 20. The ribs may be arranged substantially parallel to a longitudinal axis of the sphincter section 20, circumferentially about the perimeter of the sphincter section 20, diagonally, helically, combinations thereof, etc. In one embodiment, anti-twist rings are disposed about sections of the distal end of the system, such as the sphincter section and the distal end of the extracorporeal section 22. The rings may be longitudinally spaced from one another and may be inflatable similar to the ribs. The rings and/or ribs may be incorporated along the distal end of the system to provide an anti-rotating function. Further, the rings and/or ribs may include a reinforcing feature, such as a hard material (e.g., wire), to prevent collapse of the system lumen transporting fecal material from the patient. In one embodiment, a stiff tube or coiled, flexible spring is disposed in a wall of a section of the waste transport device or along an internal surface thereof.

[0077] With reference to FIGS. 2B and 2I, inflation lumen 36 and irrigation/sampling lumen 38 can be located adjacent and parallel to lumen 34 and on opposite sides thereof. The inflation lumen 36 and the irrigation/sampling lumen 38 can each be a flexible cylindrical tube extending along and integrally molded with, embedded into, or otherwise attached to an inner surface of at least a portion of the rectal section 18, sphincter section 20 and extracorporeal section 22. The distal end of the inflation lumen 36 is in fluid communication with the interior of the retention cuff balloon 24, while the proximal end of the inflation lumen 36 diverges from the extracorporeal section 22 outside of the body when the system is properly inserted. An inflation port 40 is attached to the proximal end of the inflation lumen and may include a luer-style connector for connection to a syringe or other device for selectively inflating and deflating retention cuff balloon 24. The distal end of the irrigation/sampling lumen 38 extends through the rectal section 18 and has a distal opening positioned adjacent the distal opening 31 of the collection member 32 so that fluids may be drawn from the patient therethrough. The proximal end of the irrigation/sampling lumen 38, similar to that of the inflation lumen, diverges from the extracorporeal section 22 and terminates at an irrigation/sampling port 42. The port 42 may similarly include a luer-style connector for connection to a syringe or other device so that, for example, a medication or irrigant may be infused into the patient's rectum, or a fecal matter sample may be extracted from the patient's rectum. In one embodiment, both the inflation lumen 36 and sampling lumen 38 are polyurethane or silicone tubes, having sizes in the range of about 5 Fr to about 10 Fr, for example, a 6 Fr inflation lumen and an 8 Fr sampling lumen.

[0078] According to certain embodiments, a pressure or volume indicator may be used with the waste management systems disclosed herein. It can be important to ensure that the retention cuff is inflated with a proper volume of liquid to provide optimum retention. Excessive volume in the cuff can lead to excessive pressure exerted by the external surface of the cuff on the rectal mucosa. This excessive pressure can damage the mucosa, and should be avoided. FIG. 26A illustrates pressure gauge 1810 in fluid communication with inflation port 40. Once the cuff is infused with, e.g., 40 ml of a liquid and the syringe is removed from the luer-style connector, the pressure gauge 1810 is locked onto the connector. As shown in FIG. 26 B, the gauge 1810 may include indicia 1812, a sealing member 1814, and a calibrated spring 1816. Any gauge capable of measuring at least one of volume and pressure may be used in accordance with the present disclosure. FIG. 27 illustrates gauge 1850 having pressure or volume actuated needle 1856, and visible range markings 1852 and 1854. The



range marking 1852 can designate an acceptable pressure or volume range, and range marking 1854 can designate an unacceptable pressure or volume range.

**[0079]** With reference to FIGS. 26A-B, pilot balloon 132 is in fluid communication with retention cuff 24. The pilot balloon 132 is configured to indicate the inflation status of the retention cuff 24, and the status is commonly detected by observing the size of the pilot balloon or detecting the pressure sensed between two fingers on the surfaces of the pilot balloon. Pilot balloons are discussed in U.S. 4,016,885; 4,134,407; and 6,732,734, the disclosures of which are incorporated by reference herein. According to one embodiment (not shown), the pilot balloon has at least one valve, for example a duckbill valve, within the chamber thereof. The valve can be calibrated to release fluid from the retention cuff when the pressure exerted by the retention cuff on the rectal mucosa exceeds a pre-defined pressure. According to certain embodiments, a preferred pressure is 15-40ml Hg. Thus, the at least one valve could be configured to release fluid when the pressure exceeds, e.g., 50, 60, 70, or 80ml Hg, or any other clinically significant pressure. According to another embodiment, waste management system could comprise a plurality of valves in fluid communication with the retention cuff 24, each of which is configured to release a specified volume of fluid when a specified pressure is reached. Such a system would provide a compensatory system that would help minimize the likelihood of tissue damage from, e.g., over-inflation of the retention cuff 24.

**[0080]** Also, as seen best in FIGS. 2A and 2F, the extracorporeal section 22 can include a flush lumen 44 disposed along a length of the extracorporeal section 22 in parallel with the central lumen 34. The flush lumen 44 is configured to flush and clean the central lumen 34 as necessary. For example, it may be desired to periodically flush the lumen 34 of the body 12 in order to prevent bacterial contamination and to also aid in reduction of odor due to fecal build up. In one embodiment, the flush lumen 44 is closed at a distal end (e.g., the distal end of the extracorporeal section 22) and connects at a proximal end to a flush port 46 coupled to, and extending through, a wall of the extracorporeal section 22 (FIG. 1) that provides access for a syringe or other device for inputting a desired cleansing fluid into the flush lumen 44. A port cover 48 (FIG. 1) of any suitable variety may be used that is configured to sealably close and open the flush port 46. Referring to FIG. 2A, to facilitate flushing of the central lumen 34, the flush lumen 44 can be perforated with a plurality of apertures 50 positioned along the length of the flush lumen 44. In one embodiment, the

apertures 50 are grouped into aperture groups 52, such as groups of four, spaced from one another along the length of the flush lumen. The apertures may be arranged substantially linearly, as shown, or may be otherwise disposed, for instance, in circular patterns, along separate or continuous curves, etc.

**[0081]** The collection member 32 and sphincter section 20 may be formed together into a single piece, such as member 120, shown in FIG. 6. Member 120 includes a collection member 32 that is unattached to the sphincter section 20 at its proximal end, the attachment occurring only at a distal end where the member 120 forms a rolling portion 122. Thus, the wall 121 defining the lumen through member 120 extends from a proximal end 118 to the distal end of the collection member 32, turning back at the rolling portion 122 toward the sphincter section 20, and terminating at a distal end 119 where it attaches to a proximal end of a retention cuff 24 (the retention cuff 24 having a distal end attached adjacent to the rolling portion 122). This configuration permits free motion and movement of the sphincter section 20 with respect to the retention cuff 24 such that the cuff is not significantly displaced (if at all) when the sphincter section 20 is twisted (as represented by arrow 8 and the dotted lines) or pulled axially, thereby isolating potential loads from the retention cuff 24, rather than transferring loads thereto. Applicants believe that by generally preventing the transfer of loads from proximal sections of the waste transfer member to the retention cuff, several benefits may be realized, such as, for example, minimization of leakage around the retention cuff and minimization of pressure exerted on the rectal vault (thereby reducing the incidence of pressure necrosis).

**[0082]** Further, a distal-only attachment configuration enables movement of a tool 112 over the length of the member 120 to facilitate insertion and removal of the waste transport device, as well as “milking” of the collection member 32. In particular, a tool 112 may include an end piece 116 coupled to an elongate member 114, the end piece 116 having a cross-section similar to the cross-section of the member 120, a size less than that of the collection member 32 in its expanded configuration, and a rigidity greater than that of the collection member 32. For example, if the member 120 has a generally hourglass shape as shown in FIG. 7, the end piece 116 of the tool 112 can be circular with a diameter generally equal to the desired insertion diameter for the collection member 32. Thus, insertion is facilitated by merely pushing on the proximal end of the elongate member 114 such that a force is exerted on the rolling portion 122 from an inner surface thereof by the end piece 116,

while the distal end of the collection member 32 is maintained in a collapsed configuration with a lower profile than that of the collection member in its expanded configuration. Following insertion, the tool 112 may be slid in a proximal direction while the member 120 is maintained in position in the patient to permit expansion of the collection member 32 to its expanded configuration. During use, the member 120 may be “milked” by sliding the tool 112 over the member 120 and performing successive axial movements, distal to proximal, to move the waste through the lumen of the member 120. To remove the waste transport device, the tool 112 is slid over the member 120 to the distal end rolling portion 122 in order to collapse the collection member 32 to the collapsed configuration having a suitable insertion/removal diameter.

**[0083]** In another embodiment, collection member 32 and sphincter section 20 are formed into a continuous member 90, shown in FIGS. 7A-7B. In the embodiment shown, member 90 includes a stiffening ring 92 around a circumference of the collection member 32 and relief sections 93 disposed approximately equidistantly between the inflation lumen 36 and the sampling lumen 38 to facilitate collapse of the collection member 32 for delivery and withdrawal from the patient’s rectum. The relief sections 93 may be raised portions of the collection member inner surface, for example, having a semi-circular cross-section along its length. The distal end of the collection member includes a lip 96 about the circumference of the distal opening 31. Openings 94 in a wall of the collection member are configured to pass air or fluid from the inflation lumen 36 to a surrounding retention cuff (it is noted that the distal end of the inflation lumen shown open in these figures will be closed in a final assembly so that air or fluid will be forced out of the openings 94). The collection member 32 has a generally frusto-conical shape, while the sphincter section 20 has a generally cylindrical shape. FIG. 7C is one embodiment of a retention cuff 123, having a bulb-like geometry along a body 124 and a tapered distal end 125. The retention cuff 123 is configured to fit over the collection member 32 and is attached at distal end 125 to the distal end of the collection member 32 and at proximal end 129 to a proximal end of the collection member 32.

**[0084]** FIG. 7D illustrates one embodiment of a waste management system 100, including a waste transport device 101 and a waste collection device 102. Waste transport device 101 includes member 90 and retention cuff 25 of FIGS. 7A-C, an extracorporeal section 22, a connector housing 126, connector collar 127 and connector ball valve 160

(described in more detail below), and devices for fluid movement, including arm flush lumen 131, arm pilot balloon 132 and arm irrigation sleeve 133. Waste collection device 102 includes a collection container 30, a hub socket 35 configured to receive connector housing 126, and hub plug 6 tethered to the hub socket 35, the hub plug 6 including threads for mating with an interior threaded surface of hub socket 35 in order to seal the opening of the collection container 30. FIG. 7E is a cross-sectional view of the collection container interface, showing connector housing 126 and hub socket 35 in more detail. FIG. 7F is a cut-away view of arm flush lumen 131 and its connection to flush lumen 44 of extracorporeal section 22. FIG. 7G is a cross-sectional view of both the arm pilot balloon 132, connected to inflation lumen 36, and arm irrigation sleeve 133, connected to sampling lumen 38. It is noted that the hexagonal section of the arm pilot balloon is configured to bulge outward when there is line pressure to indicate such to the user.

**[0085]** Another embodiment of a waste management system is illustrated in FIGS. 8A-8D. Waste management system 110 includes waste transport device 111 with a relatively shorter length than waste transport device 101 and a waste collection device 109 with a different configuration than waste collection device 102. In particular, waste collection device 109 has a tubular shape with a proximal opening covered by a sealed septum 105. An odor control filter, made of a material such as carbon, may be embedded in the wall of the waste collection device 109 or may be a vent disposed therein. The waste collection device 109 may have a collapsed configuration which expands upon receipt of waste material therein, or may have a more rigid configuration (as shown) such that a vent in a wall thereof may enhance drainage efficiency.

**[0086]** The waste transport device 111 includes an extracorporeal section 22 with a drain tube irrigation port 95, an inflation port 107 and a sampling port 108. The inflation port 107 is connected to an inflation lumen 36 extending from the inflation port 107 to the retention cuff 24, while the sampling port 108 is connected to a sampling lumen 38 extending from the sampling port 108 to the distal end of the waste transport device 111. The irrigation port 95, as shown in FIG. 8D, is connected to a flush lumen with patterned holes along its length to flush the lumen of the extracorporeal section 22. As fluid is introduced through the port 95, the fluid extends along the length of the flush lumen entering into the lumen of the extracorporeal section 22 through the patterned holes. The irrigation port 95 in one embodiment is an EZ-LOK® Sampling Port. In another embodiment, an EZ-LOK®

Sampling Port is also positioned on the extracorporeal section 22 with access to the lumen thereof for periodic sampling of fecal matter therefrom.

[0087] As best seen in FIG. 8B, a continuous member 91 includes both the sphincter section 20 and collection member 32. The collection member 32 has a wavy perimeter with undulations including peaks and valleys. The valleys 97 form crease lines to facilitate collapse of the collection member 32 to a collapsed configuration. A retention cuff 24 surrounds the collection member 32. Collapsible struts 98 are positioned at the peaks of the perimeter, forming a stiffening area to resist collapse of the collection member during use. The struts 98, as shown, extend circumferentially away from the perimeter along an outer surface of the peak section and form a recessed region along an inner surface of the peak section of the collection member. Such a shape is designed to fit in an insertion tool such that collapse of the collection member is facilitated. In other embodiments, the struts 98 may take a different geometric shape or form, depending on the shape/size of the insertion tool and/or desired levels of stiffness for the collection member. The waste transport device 111 includes at its proximal end a connection member 103 configured for coupling to connection member 104 of the waste collection device 109, embodiments of which are described in more detail below.

[0088] In the embodiments described herein, the extracorporeal section 22 may have a uniform cross-section along its length (e.g., circular, oval, etc.) or a transitional cross-section similar to the sphincter section 20 shown in FIGS. 2A-2B. The extracorporeal section 22 can be formed of a non-collapsible tube constructed of a material that is sufficiently stiff in order to maintain its shape during use (e.g., to prevent or minimize kinking, to facilitate drainage, etc.), but soft enough to be “milked” by a care professional to force through fecal material when necessary. For example, in one embodiment, the extracorporeal section is made from a rubber or plastic material that does not collapse under its own weight. In one embodiment, the extracorporeal section 22 includes one or more stiffening structures, such as inflatable ribs, metal wires or ribbons, axially positioned rings, etc., to assist in preventing collapse of the lumen 34. As with the ribs discussed above, the stiffening structures may be disposed longitudinally, circumferentially, helically, etc.

[0089] The “milked” in one embodiment is performed by a clamp tool including opposing first and second arms attached to a handle, the first and second arms arranged approximately perpendicular to the handle with a gap therebetween. A portion of the

sphincter section 20 or extracorporeal section 22 is placed between the arms and the handle is pulled in a proximal direction to move fecal matter through the section milked. The tool may include a locking feature such that the first arm locks or is coupled to the second arm to clamp a section of the waste transport device.

**[0090]** The body 12 can be secured to the collection container 30 via respective connectors 26 and 28. With reference to FIG. 1B, the collection container 30 is in the form of a bag, having an opening 54 located on a front side, which provides access to the interior thereof. In other embodiments, the collection container 30 may be in other suitable forms with one or more openings therein. Because it is desirable to secure the body 12 to the collection container 30 so that the central lumen 34 is in fluid communication with the interior of the collection container 30, the connection system positions the lumen 34 substantially in axial alignment with the opening 54 when the body 12 is coupled to the collection container 30. In one embodiment, the collection container 30 is configured to absorb and reduce odor, for example, by providing a ventable section including activated charcoal. The activated charcoal can be changed when desired via interchangeable charcoal cartridges that are inserted into the collection container 30. The collection container 30 can also have a parylene coating, anti-odor coating and/or antimicrobial coating. In addition, the collection container 30 can include material in a wall thereof that absorbs/binds odor. Suitable examples of coatings/materials include those disclosed in U.S. Patent No. 6,579,539, U.S. Patent No. 6,596,401, U.S. Patent No. 6,716,895, U.S. Patent No. 6,949,598, and U.S. Patent No. 7,179,849, each of which is incorporated by reference in its entirety into this application.

**[0091]** In the embodiment of FIG. 1B, the collection container connector 28 includes a slide mechanism adapted to receive and retain an annular flange extending from the body connector 26. Accordingly, the body 12 can be secured to the collection container 30 by sliding the annular flange section of the catheter connector 26 into a slot or grooved section of the container connector 28. When it is desired to separate the body 12 from the collection container 30, the body connector 26 can be slid upwards, out of the container connector 28, thereby disengaging the body 12 from the collection container 30. Because it is often desirable to prevent leakage from the body 12 and the collection container 30 upon separation of the body 12 from the collection container 30, closures valves 56 and 58 can be provided in the proximal opening of each. In one embodiment, the closure valves 56 and 58 are split

polymeric coverings, such as septums, that open when fluid pressure acts thereon from the fecal matter and/or flush lumen fluid in central lumen 34. In other embodiments, the valves open upon connection between the body 12 and collection container 30. For example, a mechanism on connector 26 and/or 28 will open one or both of the valves 56, 58 when the annular flange of the connector 26 is slid into the slot of the connector 28.

**[0092]** Another embodiment of a connection system for the waste management system is shown in FIGS. 9A-9D. A catheter connector 126 includes a ball valve 160 that is rotationally held in the catheter connector 126 and has an internal channel 162 extending between openings 164 and 166 located on opposite ends of the ball valve 160. A nub 168 extends from a portion of the ball valve 160. FIG. 9B shows the configuration of the ball valve 160 when the connector 126 is in a sealed position and separated from a collection container. Here, the openings 164 and 166 and the interior channel 162 do not align with the central lumen 34 of the catheter, thereby sealing the proximal opening of the body 12. However, in the open position, as illustrated FIGS. 9C and 9D, the ball valve 160 is rotated so that the channel 162 and openings 164 and 166 are aligned with the central lumen 34 when the connector 126 is connected to the collection container connector 128. A divot 170 located in the container connector 128 is configured to trap and move the nub 168 when the catheter connector 126 is secured to the container connector 128. As shown in FIG. 9C and 9D, when the container connector 128 and the catheter connector 126 are brought together, the nub 168 is moved rearward, causing the ball valve 160 to rotate to its open position. In one embodiment, the connection between the body 12 and the collection container 130 is securely held together by a bayonet type mechanism or other types of known securing mechanisms.

**[0093]** As shown in FIG. 9A, the collection container 130 may include a Velcro strap 172 adapted to be an effective handle and to securely hang the collection container 130 from a patient's bed. The Velcro strap 172 can be fastened at one end to the container connector 128 with a free end including a Velcro strip affixed to one side for engagement to a corresponding receiving strip affixed to a part of the strap adjacent the end fastened to the container connector 128. Thus, attachment to a patient's bed or other structure is easily accomplished by separating the free end of the strap 170 from the receiving strip, looping it through an opening in the structure, and reattaching the free end to the receiving strip. Alternatively, the collection container 130 may include a hook or other like member to hang

the collection container 130 from the patient's bed. The collection container 130 may be substantially opaque with a transparent strip 174 extending from a lower portion of the container to an upper portion thereof. The transparent strip 174 can be located on multiple sides of the container (e.g. front, first side, second side and back), or only a single side as shown. The opaque portion of the container 130 substantially conceals the contents of the container, while the transparent strip 174 provides a means to visually monitor the volume of waste in the container so that it can be emptied before reaching a maximum level.

**[0094]** In another embodiment of a connection system for the waste management system, a guillotine connection assembly shown in FIGS. 10A-10E includes a body connector 226 and a container connector 228. The container connector 228 includes a first slide 276 held between two sidewalls 278a and 278b and moveable therealong. An upper end of the first slide 276 has a tab 280 for gripping and a lower portion of the slide 276 includes an aperture 282. When the first slide 276 is in a closed position, as shown in FIG. 10A, a collection container opening is covered by the slide 276. The first slide 276 is moved upward to place in an open position, in which the slide aperture 282 is aligned with the collection container opening. The body connector 226 includes a pair of locking arms 284a and 284b extending from the sides of the connector 226. A second slide 286 is held between the locking arms 284a and 284b and includes an aperture 288 located on a lower portion thereof having approximately the same size and shape as the aperture 282 on the first slide 276.

**[0095]** To form a connection between the body 12 and the collection container 230, the second slide 286 is positioned such that the ends of the locking arms 284a and 284b are positioned adjacent corresponding slots 290a and 290b of the container connector 228 and the apertures 282 and 288 are aligned. The locking arms, which may include a feature that indicates a positive connection (e.g., tactile, audible, etc.), are then pressed into the slots 290a and 290b such that the body 12 is coupled to the collection container 230. The tab 280 is then pulled in an upward direction, causing both the first slide 276 and the second slide 286 to move into an open position, in which the lumen 34 of the body 12 is aligned with the collection container opening to place the collection container 230 in fluid communication with the body 12. In one embodiment, movement of the tab 280 in an upward direction locks the connectors 226, 228 together to prevent inadvertent separation during use. When it is desired to remove the collection container 230 from the body 12, the tab 280 is pushed in a downward direction, sealing both the opening of the collection container 230 and the opening



in the body 12 and unlocking the connectors 226, 228 for separation. In one embodiment, the locking arms 284a and 284b include a clamping mechanism that can be opened by pressing a proximal end toward the connector 226 and closed by releasing the end. Thus, to release connector 226 from connector 228, the clamping mechanism on arms 284a, 284b is opened.

[0096] A variation of a guillotine connection assembly is shown in FIGS. 11A-11D. As seen in FIG. 11A, an ostomy bag flap seal 310 seals the opening of the collection container 330. A body connector 326 coupled to the body 12 includes a disk 312 positioned on a side of the connector 326 opposite the face that can be moved between a sealed position (shown in FIG. 11B) and an unsealed position (shown in FIG. 11C). Nubs 314a and 314b extending from opposing sides of the disk 312 are held in respective tracks 316a and 316b of the catheter connector 326, permitting the disk 312 to slide in upward and downward direction, as shown in various stages in FIG. 11D. When the catheter connector 326 is separated from a container connector 328, the disk 312 is in the sealed position. The connector 326 is attached to the container connector 328 by sliding the track of connector 326 over the rail of connector 328, by pressing the connector 326 onto the connector 328, or other manner of connection known to one skilled in the art. Following connection, the disk is pushed up the tracks 316a and 316b to unseal the body proximal opening and place the body 12 in fluid communication with the collection container 330. FIG 11C illustrates an embodiment of a hook/handle 316 attached to the collection container 330, which may be integral with the collection container connector 328 and can serve to hold the collection container 330 on a patient's bed, as well as providing a handle for the collection container 330.

[0097] Yet another manner of connecting a catheter to a collection container is shown in FIG. 12. A container connector 428 attached to a collection container 430 includes a housing 410 having an opening 412 to the interior of the collection container and a cap member 414. The cap member 414 can be securely snapped onto the housing 410 over the opening 412 to seal the opening 412. A body connector 426 coupled to the body 12 includes a reduced diameter section 416 at its proximal end that is configured for insertion into the opening 412 of the container connector housing 410. Locking tabs 420a and 420b are located on opposite sides of the reduced diameter section 416 and are configured to slide into corresponding slots 422a and 422b extending along the interior of the container connector housing 410. When fully inserted, the locking tabs 420a and 420b engage notches (not

shown) in slots 422a and 422b to secure the catheter to the collection container 430. In addition, the locking tabs 420a and 420b may produce an audible indication to the user that the tabs have been fully inserted into the slots 422a and 422b and that the connection is secure. In one embodiment, a ball valve 424 is positioned in the connector housing 416 that rotates between a sealed position when the body 12 is separated from the collection container 430 and an unsealed position when the body 12 is secured to the collection container 430. The catheter connector 426 and the collection container housing 410 may also include one or more grips 440 to facilitate use. In addition, the connector housing 416 may include one or more integrated ports, as shown in FIG. 12. Thus, for example, a first port 442 may be in fluid communication with the irrigation/sampling lumen 38, a second port 444 may be in fluid communication with inflation lumen 36, and a third port 446 may be in fluid communication with the flush lumen 44. The collection container 430 includes a rigid, curved handle 450 affixed to and extending from a top thereof, which may aid a user in carrying the collection container 430 for disposal and/or serving as a hook to quickly and easily hang the collection container 430 from a patient's bed.

**[0098]** FIGS. 13A-13C illustrate an embodiment of a connection system similar to that of FIG. 12. In this embodiment, a body connector 526, coupled to the body 12, includes a duckbill valve 510 and a container connector 528 includes a concentric tube 512 with an angled face that is configured to force the valve 510 open upon contact therewith. The duckbill valve 510 is sealed when the body 12 is separated from the collection container 530 and opens as the end of the body connector 526 is inserted into the container connector 528. In one embodiment, a visual indicator is provided with the connection system to indicate a proper and secure attachment of the body connector 526 to the container connector 528. In the example of FIG. 13, best seen in FIG. 13B, an indicator 514 (e.g., a raised surface, a symbol or geometric figure with a different color than the surface on which it is placed, etc.) is located on a surface of the reduced diameter section 510 of the body connector 526. A complementary feature on the container connector 528, such as an aperture 516 with the same shape as the indicator 514, provides confirmation to the user of a secure connection when the indicator 514 is fully visible through the aperture 516.

**[0099]** Another example of a connection system is shown in FIGS. 14A-D. A cylindrically shaped body connector 626 includes a flexible tube 610 positioned inside a channel. A first annular ring 612 is affixed to a distal end of the flexible tube 610 and to the

interior wall of the body connector 626. A second annular ring 614 is affixed to a proximal end of the flexible tube 610 and is rotatably held in body connector 626. As shown in FIG. 14A, the flexible tube 610 is biased in a twisted position to seal the proximal opening of the body 12. In order to open the proximal opening, the tube 610 is untwisted as shown in FIG. 14C. Untwisting the tube 610 is accomplished by first inserting the end of the body connector 626 into the container connector 628 of a collection container (FIG. 14D) such that a tab 616 of the container connector 628 is positioned inside a corresponding slot 618 on the body connector 626, located on the second annular ring 614 (FIG. 14A). Next, the end of the body connector 626 is rotated, causing the second annular ring 614 and the proximal end of the flexible tube 610 to also rotate, thereby unsealing the opening of the body 12. Various suitable connection mechanisms can be used to secure the catheter connector 626 to the container connector 628. For example, FIG. 14D shows a bayonet style connection mechanism that gives positive feedback to the user when connection is complete. In addition, the collection container opening can be sealed by various suitable mechanisms, including a standard ostomy bag flap as discussed above.

**[00100]** Turning now to FIGS. 15A-15D, one embodiment of an insertion device for a waste management system is illustrated. The insertion device 700 is configured to facilitate insertion of a waste transport device. Insertion device 700 includes an inner sleeve 702 and an outer sleeve 704, each having a generally tubular configuration and flanges at a proximal end thereof. The outwardly extending flanges of the outer sleeve 704 are configured to prevent over-insertion of the device 700, indicating to a user that maximum safe insertion has been reached when the flanges are adjacent a patient's buttocks. The outwardly extending flanges of the inner sleeve 702 provide an indication to the user that the retention cuff has moved distally through the distal end of the outer sleeve 704 when the outer sleeve flanges are adjacent thereto. The proximal end of both the inner sleeve 702 and the outer sleeve 704 include respective pairs of c-rings 706a, 706b and 708a, 708b positioned on the respective flanges. Each pair of c-rings 706a, 706b and 708a, 708b are separated by a pair of v-cuts 710 and 712 (only one side of v-cuts shown in FIG. 15A). The v-cuts 710 and 712 facilitate disassembly of the sleeves 702 and 704 from the body 12 post insertion, as the v-cuts feed into a split section (e.g., an elongate score from the v-cut to the distal end of the sleeve) that separates the sleeve into two pieces. The insertion device 700 is shown on the body 12 in an insertion configuration in FIG. 15B, a distal end of the outer sleeve 704 covering the rectal section 18, the retention cuff 24 held by the outer sleeve 704 in its collapsed configuration.

In one embodiment, the outer sleeve 704 is configured to compress the retention cuff 24 in order to provide a lower profile for the device 700.

**[00101]** FIG. 15C shows the insertion device 700 as it is retracted from the rectal section 18, the end of the outer sleeve having a perforated section to permit passage of the rectal section 18 therethrough. Retraction of the outer sleeve 704 may occur during insertion due to forces acting on the insertion device 700 or may be manually performed by a user following insertion. FIG. 15D shows retraction of the outer sleeve 704 and initial removal of the insertion device 700 from the body 12. It should be noted that the retention cuff may self-expand following retraction of the outer sleeve 704 in some embodiments, and in others will require inflation. Following proper positioning of the body 12 in the patient, the insertion device 700 can be disassembled by grasping the pair of c-rings 708a and 708b and pulling the outer sleeve 704 apart along its v-cuts 712, and then grasping inner sleeve 702 in a similar manner and pulling apart and off of the body 12. Removal of the device 700 may occur after only a portion of the outer sleeve 704 is retracted from the rectal section 18 or after the device 700 is slid proximally further along the body 12.

**[00102]** Another embodiment of an insertion device is illustrated in FIGS. 16A-C. The insertion device 800 includes a disposable sleeve with an outer portion 804 folded over an inner portion 802 in a rolling diaphragm arrangement. The inner portion 802 may have a suitable adhesive disposed on an inner surface thereof to prevent migration of the device 800 during insertion. A first end of the sleeve, initially inner portion 802, includes a pair of inner cuff rings 806a and 806b, while a second end of the sleeve, initially outer portion 804, includes a pair of outer cuff c-rings 808a and 808b. FIG. 16A shows the device 800 in an insertion position with the retention cuff 24 folded and held in a folded state by sleeve outer portion 804. To deploy the waste transport device in the patient, the outer portion 804 is pulled in a proximal direction, as shown in FIG. 16B, until fully pulled from over the inner portion 802, as shown in FIG. 16C. In this position, the retention cuff 24 is released from its folded position and allowed to expand and/or inflated. The insertion device 800 is removed by pulling the c-rings 808a and 808b apart so that the v-cuts 810 expand, separating the sleeve into two pieces, and pulling away from the body 12. FIGS. 17A-17D illustrate a variation of device 800 with inner cuffs 906a and 906b that have a longer length than cuffs 806a and 806b. The length of the cuffs (e.g., in the range of about 1 inch to about 2 inches) provides clamping to prevent migration, thereby potentially eliminating the need for an

adhesive on the inner surface of the inner portion 804. In one embodiment, the insertion device 800 includes dimpled c-rings to help a user load the catheter correctly. In another embodiment, a reduced diameter section 912 is included where the inner portion 802 and outer portion 804 of the sleeve meet when in the insertion position. As shown in FIG. 17D, when the outer portion is pulled in the proximal direction, the reduced diameter section 912 may indicate to a user when the insertion device 800 is fully unrolled to the correct point of insertion. The reduced section 912 also provides a narrower entry for the device 800 at the insertion point.

**[00103]** Another embodiment of an insertion device is illustrated in FIGS. 18A-18C. Insertion device 1000 includes a separate inner sleeve 1002 and outer sleeve 1004, similar to the embodiments of FIG. 15. In this embodiment, a distal end of the outer sleeve 1004 includes a tapered head 1010 to facilitate insertion by providing a smaller profile. The tapered head 1010 can also provide a smooth transition from the sphincter section 20 of the catheter and can be constructed of a flexible material with rounded edges to minimize discomfort. In addition, the insertion device 1000 can include an increased diameter limiter flange 1012 extending from a proximal end of the outer sleeve 1004. The limiter flange 1012 can be configured to assist a user to locate a proper insertion depth. For example, the limiter flange 1012 can be set at a predetermined distance along the insertion device 1000 so that a person administering the body 12 can use the limiter flange 1012 as a reference as to how far the body 12 is inserted into the patient. The limiter flange 1012 can also limit the depth that the insertion device 1000 can be inserted into the patient. FIG. 18B shows the insertion device 1000 in a retracted configuration with the rectal section 18 with retention cuff 24 released and expanded. As the outer sleeve 1004 is retracted, the head 1010 of the insertion device 1000 splits apart at a plurality of tear away seams 1024 to permit relative distal movement of the body 12.

**[00104]** The insertion device 1000 is removed from the body 12 by pulling the outer sleeve 1002 and inner sleeve 1004 apart at tear zones 1014 and 1016, respectively, that begin with corresponding v-cuts 1018 and 1020. In one embodiment, the insertion device 1000 includes one or more “rip strips” to facilitate disassembly of the insertion device 1000. An exemplary rip strip 1022, shown pulled away from the outer sleeve 1004, is illustrated in FIG. 18C. One or more rip strips may also be included on the inner sleeve 1002.

**[00105]** Yet another embodiment of an insertion device is illustrated in FIGS. 19A-C. In this embodiment, the insertion device utilizes a scissor action similar to that of a disposable vaginal speculum. A catheter, such as body 12, has a plunger 1102 disposed about a distal portion thereof, the plunger 1102 including a pair of grips 1104a and 1104b extending from its proximal end configured for removing the plunger 1102 following insertion of the body 12 in the patient. A scissor device 1106 includes a rigid upper arm 1108 and a rigid lower arm 1110 pivotally connected to one another at pivot point 1112. A soft, flexible sleeve 1114 is positioned around an upper portion of the scissor device 1106, which covers the pinch points of the scissor device 1106 and provides a protective cover for at least a portion of the body 12 and/or plunger 1102 during insertion. As shown in FIG. 19B, squeezing handles 1116 and 1118 together causes the pivotal movement of the upper arm 1108 away from the lower arm 1110, which may be limited by the sleeve 1114. For insertion, the distal portion of the body 12 and plunger 1102 are inserted into a proximal opening of the scissor device 1106, either before or after the scissor device 1106 is inserted into a patient. The handles of the device 1106 are then squeezed together to facilitate insertion of the body into the patient. The plunger grips 1104a, 1104b extend outward from the plunger and may be spaced from a distal end of the body 12 to indicate to the user a proper depth of insertion or to indicate the maximum safe depth of insertion when the grips 1104a, 1104b come into contact with a proximal end of the device 1106. One or more tear-away bands may be included on the plunger 1102 to facilitate removal.

**[00106]** Still another embodiment of an insertion device is illustrated in FIGS. 20A-20C. Insertion device 1200 includes an upper sleeve 1202 attached along one or more tear away seams 1210 to a lower sleeve 1204. A spacer 1212 is provided to indicate proper or safe insertion depth of the device. A handle 1214 is provided at the proximal end of the lower sleeve 1204 to facilitate handling and insertion. The upper sleeve 1202 in one embodiment is made of a material that more flexible than the lower sleeve 1204. In the insertion configuration shown in FIG. 20A, the insertion device 1200 compresses the folded retention cuff 24 to provide a lower profile for easier insertion into the patient. Following insertion, the device 1200 is removed by first shearing back the upper sleeve 1202, as shown in FIG. 20B, which splits a tip 1206 to expose the retention cuff 24 and allow it to expand (e.g., unfold). Then, the upper sleeve 1202 is removed from the patient, as shown in FIG. 20C, followed by removal of the lower sleeve 1204.

**[00107]** FIG. 21 illustrates an insertion device 1300 configured similar to a sheath introducer or tampon applicator. The distal end of the body 12 is inserted into the device 1300, which may have a lubricious coating on an outer surface thereof. The distal end 1302 has a plurality of petals that together maintain the folded profile of the retention cuff 24, but which split apart when the body 12 is pushed in a distal direction to permit passage of the body therethrough. To remove, the device 1300 is slid in a proximal direction along the body. The device 1300 may also include visual depth markers and/or an anchoring mechanism.

**[00108]** FIGS. 28A-28B illustrate a device 1610 for facilitating the insertion of a waste management system into the rectal vault. Ease of insertion, patient comfort, and clinician time can be important in a hospital setting. It could be advantageous to provide a device that simplifies insertion of a waste management system while minimizing discomfort to a patient. One way to accomplish the foregoing is to provide the retention cuff 24 in a folded, low-profile shape with a leading edge to provide rapid deployment and insertion with minimal steps. According to one embodiment, the waste management system is packaged such that the cuff 12 is pre-folded into sheath 1612. A lubricating agent may be provided into the interior of sheath 1612, and thus onto cuff 24, via lubrication port 1614. That is, the sheath may be removed from the waste management system packaging and, once the patient is prepped and ready for insertion, a lubricating agent may be provided through port 1614. This can be done with, for example, a syringe with a luer-type fitting complementary to the luer-type fitting of port 1614 on the sheath 1612. The lubricating agent exits the port 1614 into the interior of the sheath 1612, and coats at least a portion of the outer surface of folded cuff 24. The trans-sphincteric section 20 may then be grasped, as shown in FIG. 28B, and removed from the sheath 1612 as illustrated in FIG. 28C. Upon removal from sheath 1612, cuff 24 is pre-folded, lubricated, and ready for insertion into the rectum of a patient.

**[00109]** FIG. 22 illustrates one embodiment of a securement device for a waste management system. The securement device prevents undesired migration (both inward and outward) of the waste transport device and also protects the perianal area of a patient. In particular, due to a very weak sphincter tone the patient may have a tendency to expel the waste transport device following insertion and during use. Thus, the securement device described herein prevents the waste transport device from axial and rotational movement,

leading to several benefits including, for example, longer indwell times, leak-minimization, proper seating of the waste transport device retention cuff, etc.

**[00110]** The securement device 1400 shown in FIG. 22 includes a securement patch 1402 and securement tab 1410. The securement patch 1402 has a distal surface 1404 onto which an active ingredient material matrix is disposed, including one or more active agents, such as, for example, hydrocolloid, antibiotic, antifungal, antimicrobial, anti-odor, skin-conditioning, as well as a substrate that adheres to the skin of a patient. The adhesive patch may include release profiles for healing skin breakdown. The use of an active agent is believed to address the common incidence of decubitus ulcers and skin breakdown around the perianal and buttocks area of a patient in need of a waste management system as described herein. Examples of devices currently used to address these conditions include Tegaderm™ Dressings from 3M™ and DuoDERM® Dressings from ConvaTec. Thus, employment of an active ingredient material matrix in the securement patch 1402 imparts benefits to the securement device 1400 including, for example, the protection of a patient's skin, prevention of future skin breakdown, healing of patient's skin, prevention of infection, control of odor, etc. It should be appreciated that while the securement patch 1402 is illustrated with an active ingredient material matrix disposed on its distal surface, the adhesive matrix may instead be separate from the securement patch 1402 and applied by a clinician directly to the patient's skin.

**[00111]** The securement patch 1402, illustrated as having a clover shape, is flexible in order to conform to the shape of a patient's buttocks area and to permit patient movement without disconnecting; however other shapes are envisioned and within the scope of the invention. Also, while the securement patch 1402 is illustrated as having a flat profile, curved profiles are also within the scope of the invention. The securement patch 1402 includes a slitted section or discontinuation 1406 on one side thereof that connects to an opening 1408 having a diameter the same as, or slightly larger than, a tubular body of a waste transport device, thereby permitting positioning and attachment of the securement device 1400 to an installed waste transport device, as described in more detail below.

**[00112]** The securement tab 1410 has opposing flaps attached to the securement patch 1402 on opposite sides of the slitted section 1406. In the embodiment shown, the securement tab 1410 has an inner surface onto which an adhesive is disposed for attachment of the securement device 1400 to the waste transport device. In one embodiment, the adhesive used



for the securement tab 1410 is such that the securement device 1400 can be readily detached from the tubular body 12 to permit multiple securement devices to be utilized over the course of treatment for a patient. In other embodiments, mechanical means of attachment instead of, or in addition to, the adhesive means may be employed. For example, the securement device 1400 could include mechanical means such as hooks, loops (e.g., Velcro® securement), or ties that work together with features built into the drain tube and/or securement patch 1402. In this embodiment, the opposing flaps are bowed outward from a longitudinal axis of the securement device to facilitate axial sliding along the waste transport device for precise positioning (i.e., to prevent the inner surface from contacting the surface of the waste transport device prior to desired positioning).

**[00113]** FIGS. 23A-D illustrate the securement patch 1402 being positioned onto the tubular body 12 of a waste transport device. In FIG. 23A, the securement tab 1410 is positioned above the tubular body 12 toward the distal end thereof (i.e., adjacent a patient's buttocks following insertion of the waste transport device as described herein) so that the slitted section 1406 is facing the tubular body 12 and the opposing flaps of the securement tab 1410 are flayed outward such that the distance between them is greater than the diameter of the tubular body 12. In FIG. 23B, the securement patch 1400 is mounted onto the tubular body 12 by pressing the slitted section 1406 thereover so that the tubular body 12 is substantially within the opening 1408. FIG. 23B illustrates the next positioning step of axially moving the securement device along the tubular body 12 as necessary until the adhesive securement patch 1402 is in contact with the patient's buttocks. In FIG. 23C, the opposing flaps of the securement tab 1410 are pressed into contact with the tubular body 12, the adhesive on the inner surface 1412 of each flap bonding to the outer surface of the tubular body 12. In one embodiment, the securement patch 1402 and securement tab 1410 have a non-stick strip of material that is first removed so that the adhesive surface thereof is exposed. Thus, in the embodiment shown, the securement patch 1400 is attached to both the patient, via the securement patch, and the waste transport device, via the securement tab. FIG. 23D shows the waste transport device from an end perspective view with securement device 1400 mounted thereon.

**[00114]** It is noted that the securement patch can be incorporated into any of the embodiments described herein and could be initially separate from the waste transport device to be attached following proper insertion and positioning thereof or could be attached prior to

insertion. Further, the securement patch could be a component sold separately for use with a wide variety of waste management systems or could be included with a kit including a waste management system as described herein.

**[00115]** In another embodiment of a waste management system, a waste transport device includes a medication delivery apparatus. FIG. 24A shows one embodiment of a medication delivery apparatus 1500, including an integrated low profile interface port 1502 and a separate, independent disposable delivery device 1510, which permits dispensing medication or a therapeutic agent to a patient on an as-needed basis. The interface port 1502 includes an access face 1504 with an opening sealed by an embedded septum 1506, the septum 1506 including a slit or passage configured to permit insertion of the delivery device 1510 therethrough while preventing exposure and leakage of fecal matter. The septum 1506 also acts as a “squeegee” to clean the surface of the disposable delivery device 1510 as it is withdrawn from the interface port 1502 following use. In other embodiments, the interface port could incorporate different types of one-way valve elements in addition to, or in place of, the septum. Also, in the embodiment illustrated, the delivery device 1510 includes a nebulizing element 1512 at its distal end and an occlusion balloon 1514 just proximal of the nebulizing element 1512. While the nebulizing element is illustrated, it is noted that other types of nozzle elements known to one skilled in the art are envisioned and within the scope of the invention.

**[00116]** A shaft 1516 having an outer wall enclosing at least two lumens connects the distal end elements to a proximal end syringe port 1520. The syringe port 1520 includes a balloon port 1522, in fluid communication with a first lumen in the shaft 1516 connecting to the occlusion balloon 1514, and a drug delivery port 1524, in fluid communication with a separate second lumen in the shaft 1516 connecting to the nebulizing element 1512. The shaft 1516 is semi-rigid to permit easy insertion through the septum 1506 into the lumen of the waste transport device and travel through the lumen of the collection member without causing damage to the waste transport device during insertion and withdrawal. FIG. 24A illustrates the disposable delivery device 1510 with the occlusion balloon 1514 in a collapsed state, while FIG. 24B illustrates the disposable delivery device 1510 with the occlusion balloon 1514 in an inflated or expanded state.

**[00117]** In the embodiment shown in FIG. 24A, the medication delivery apparatus 1500 provides access to the drainage lumen of the waste transport device. The disposable

delivery device 1510 is shown with a pre-shaped bend in the shaft 1516 so that when fully inserted, the inserted portion is substantially parallel with the drainage lumen, the proximal end of the shaft extending through the interface port 1504. However, in other embodiments, the shaft 1516 could be sufficiently flexible such that no pre-shaped bend is necessary. The fully inserted disposable delivery device 1510 is shown in FIG. 24C with the occlusion balloon inflated or expanded, thereby preventing fecal matter from entering the drainage lumen of the waste transport device during delivery of a medication. By sealing the rectal vault, the medication is suspended therein to maximize efficacy of medication delivery. Typical medications include Lactulose and Kexolate, which are administered in a bolus form. The nebulizing element 1512 improves delivery of medication for optimal uptake by the mucosal tissue in the rectal vault via a distinct nebulizing nozzle, which can alternatively be configured to directionally spray, coat, or otherwise administer drug to the rectal vault in an improved manner. With better delivery and uptake by the mucosal tissue, greater efficacy is possible.

**[00118]** The medication delivery apparatus 1500 with a disposable delivery device 1510 is capable of being implemented at any time following positioning of the waste transport device. This modular aspect provides a distinct advantage over fully integrated systems that require indwelling and non-removable components within the lumen of the waste transport device, as it can be implemented only when necessary based on individual patient requirements. Moreover, the nozzle or nebulizing element 1512 permits enhanced delivery of medication or a therapeutic agent to the patient by providing to the clinician an ability to control both the depth of delivery into the colon and the type of delivery from the nozzle element. Accordingly, uptake of the delivered medication is further optimized due to the fact that blood flow in the rectal vault tissue increases distal of the sphincter.

**[00119]** FIG. 24D is a cross-sectional view of the distal end of the waste transport device of FIG. 24C, showing the nebulizing element 1512 extending beyond the distal opening of the collection member with the occlusion balloon in an inflated state. The medication delivery apparatus 1500 is implemented by inserting the delivery device 1510 through the access face 1504 and passage of the interface port 1502 and into the lumen of the waste transport device. Insertion of the delivery device 1510 continues until the nebulizing element 1512 is preferably at least partially distal of the distal end of the waste transport device. Completion of insertion is indicated when the bend in the shaft of the delivery device

contacts the lumen wall of the waste transport device (in the embodiment with a pre-shaped bend) and/or when a visual indicator on the shaft (e.g., a marking such as a ring or line) reaches the septum 1506 or some other designated point on the interface port. Once properly positioned, inflation fluid is delivered through the balloon port 1522 of the syringe port 1520 to the occlusion balloon 1514 until the balloon is inflated to the desired size to occlude the lumen of the waste transport device (e.g., the lumen of the collection member of the waste transport device). Following expansion of the occlusion balloon, a medication is delivered under pressure through the drug delivery port 1524 of the syringe port 1520 to exit the nebulizing element 1512 into the patient. After completion of medication delivery, the occlusion balloon 1514 is deflated and the delivery device is removed through the septum 1506 of the interface port and disposed in a suitable container.

**[00120]** While FIGS. 24A-D illustrate the combination of an interface port 1502 and a disposable drug delivery device 1510, other combinations are also possible and within the scope of the invention. For example, different types of instruments could be inserted through the interface port 1502 before, after, or instead of, the drug delivery device, including, for example, instruments capable of aerosolizing fluids and/or power injecting fluids, endoscopes, visualization devices, etc. Moreover, enemas can be administered through the interface port 1502. As mentioned, a flexible scope could be inserted through the interface port 1502 to visualize the indwelling components of the waste transport device and investigate any seating, leakage, or pressure necrosis issues. Such visualization inside the rectal vault permits the clinician to diagnose potential problems with the device that may be addressed without discarding the entire waste management system.

**[00121]** One skilled in the art will appreciate that providing modular catheter delivery permits the delivery system to be tuned and utilized for specific drugs and patient conditions, thereby expanding the type of medications administered via the rectal route. For instance, a typical medication delivery method involves delivery of medications via the oral naso-gastric tube route. Because the amount of fluids administered is significant (as it also includes feeding nutrition), patients generally require endotracheal tubes for delivery. However, it is known that these fluids in the stomach have a higher risk of aspiration pneumonia. On the other hand, the rectal medication delivery method and approach described herein permits reduction of the oral medication threshold, thereby reducing aspiration risk.

[00122] FIG. 25 shows another embodiment of a medication delivery apparatus. In this embodiment, rather than providing access to the drainage lumen of a waste transport device, an integrated interface port 1532 provides access through septum 1506 to a dedicated lumen 1530 having a distal end that extends through the collection member. The lumen 1530 permits the infusion of medication without a delivery device (e.g., delivery device 1510) and could potentially be configured to stiffen the sphincter section of the waste transport device.

[00123] It would be desirable to have a method for quickly and conveniently identifying certain bacteria, such as *Clostridium difficile*, in patient stool. Infections from *C. difficile* can spread rapidly and can be difficult to control. *Clostridium difficile*-associated disease can be especially dangerous to elderly and immunocompromised patients, and infection can spread rapidly throughout a hospital. It could be advantageous to provide rapid and simple test for bacteria, where the test apparatus comprises a cassette inserted into a port of a waste management system. As illustrated in FIG. 29, catheter 12 can include at least one self-sealing port 1712. Testing strips 1711 on cassettes 1710 can be inserted into the port 1712 for a defined length of time, withdrawn and, ideally, quickly indicate the presence or absence of a particular bacterium. One suitable non-limiting example of a *C. difficile* test is the *C. difficile* Toxin A test available from Oxoid Limited (Hampshire, U.K.).

[00124] While the invention has been described in terms of particular variations and illustrative figures, those of ordinary skill in the art will recognize that the invention is not limited to the variations or figures described. In addition, where methods and steps described above indicate certain events occurring in certain order, those of ordinary skill in the art will recognize that the ordering of certain steps may be modified and that such modifications are in accordance with the variations of the invention. Additionally, certain of the steps may be performed concurrently in a parallel process when possible, as well as performed sequentially as described above. Therefore, to the extent there are variations of the invention, which are within the spirit of the disclosure or equivalent to the inventions found in the claims, it is the intent that this patent will cover those variations as well. Finally, all publications and patent applications cited in this specification are herein incorporated by reference in their entirety as if each individual publication or patent application were specifically and individually put forth herein.

## CLAIMS

What is claimed is:

1. A waste management system, comprising:  
a waste transport device, including a collection member with a distal end opening having a first cross-sectional area and a proximal end opening having a second cross-sectional area less than the first cross-sectional area, a lumen fluidly connecting the distal end opening to the proximal end opening, a retention cuff disposed about an outer surface of the collection member, and an inflation port in fluid communication with the retention cuff;  
and  
a gauge configured for attachment to the inflation port, wherein the gauge can indicate at least one of volume of fluid within the retention cuff, and pressure exerted by the retention cuff on a tissue.
2. The waste management system according to claim 1, wherein the inflation port contains a luer connector.
3. The waste management system according to claim 1, wherein the gauge measures a volume of fluid within the retention cuff.
4. The waste management system according to claim 1, wherein the gauge measures the pressure exerted by the retention cuff on a tissue.
5. The waste management system according to claim 1, wherein the gauge has indicia indicating a clinically acceptable pressure or volume range.

6. A waste management system, comprising:
  - a waste transport device, including a collection member with a distal end opening and a proximal end opening, a lumen fluidly connecting the distal end opening to the proximal end opening, a retention cuff disposed about an outer surface of the collection member; and
  - a device configured to facilitate insertion of the collection member into a patient, wherein the device comprises a sheath dimensioned to receive and hold the retention cuff in a folded configuration.
7. The waste management system according to claim 6, wherein the sheath is constructed from a rigid material.
8. The waste management system according to claim 6, wherein the sheath comprises a port in communication with the internal volume of the sheath.
9. The waste management system according to claim 8, wherein the port comprises a luer fitting.
10. The waste management system according to claim 8, wherein the port is configured to receive a lubrication fluid for dispersal over a surface of the retention cuff.
11. A waste management system, comprising:
  - a waste transport device, including a collection member with a distal end opening and a proximal end opening, a lumen fluidly connecting the distal end opening to the proximal end opening, a retention cuff disposed about an outer surface of the collection member; and
  - a port in the collection member, wherein said port is configured to receive a bacterial testing apparatus.
12. The device according to claim 11, wherein the bacterial testing apparatus is a cassette.
13. The device according to claim 11, wherein the bacterial testing apparatus is capable of testing for the presence of *Clostridium difficile* toxin in stool.





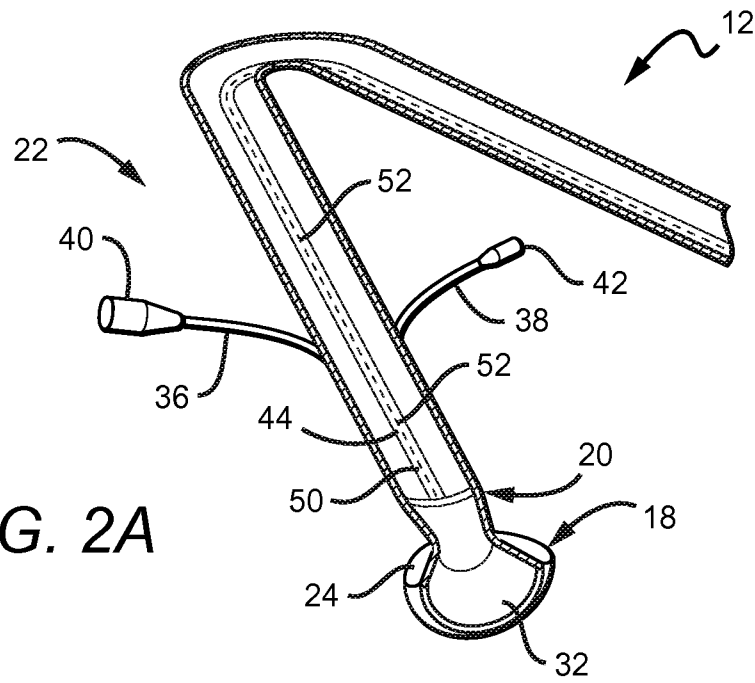


FIG. 2A

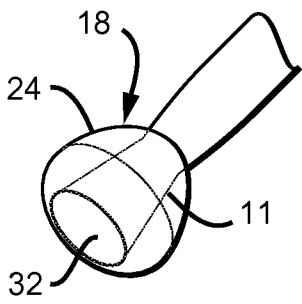


FIG. 2C

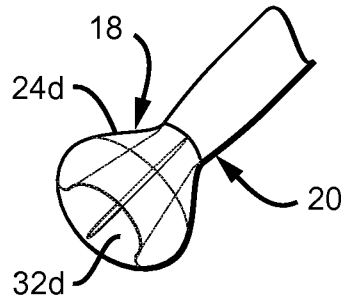


FIG. 2D

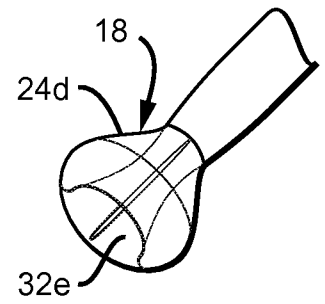


FIG. 2E

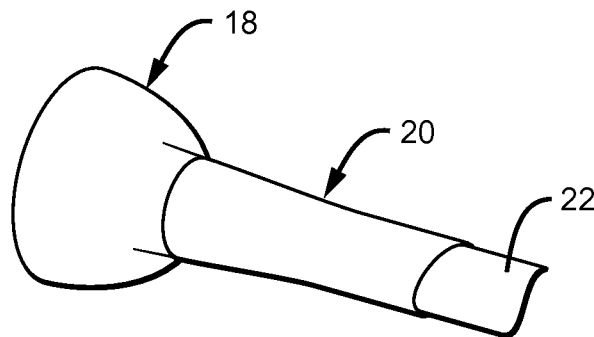


FIG. 2F

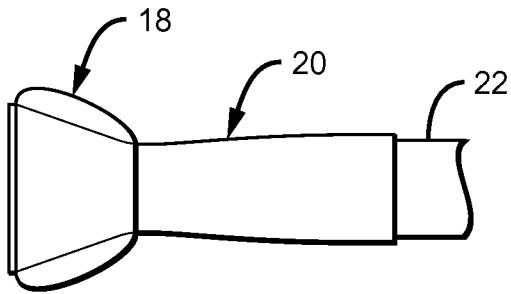


FIG. 2G

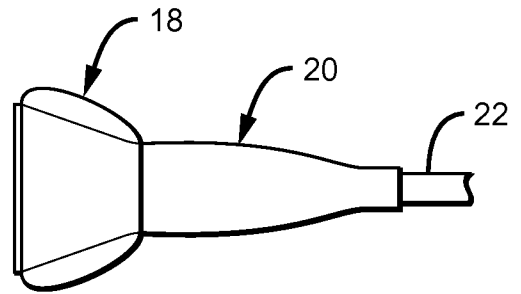


FIG. 2H

FIG. 2I

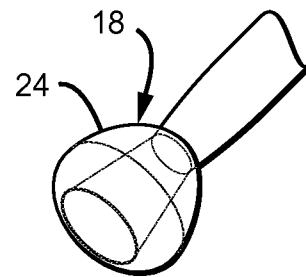
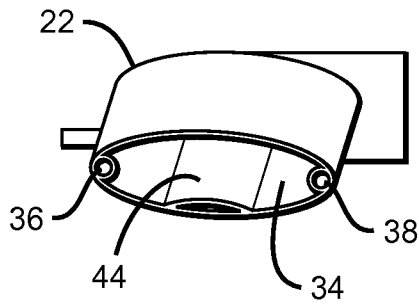


FIG. 3A

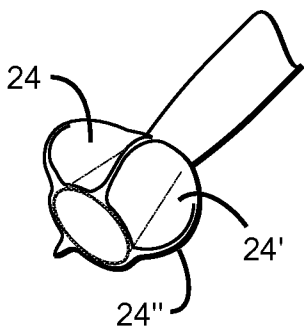


FIG. 3B

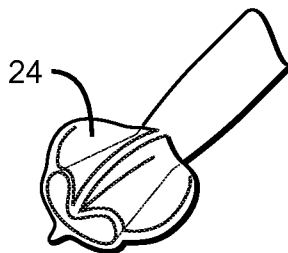


FIG. 3C

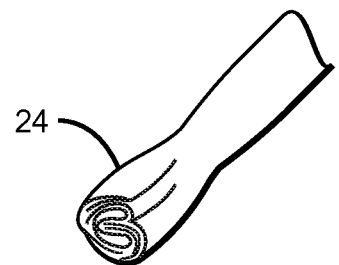


FIG. 3D

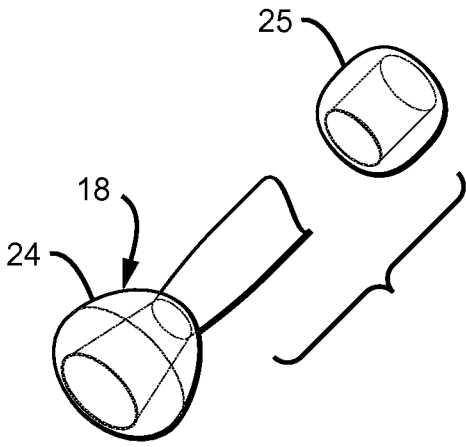


FIG. 4A

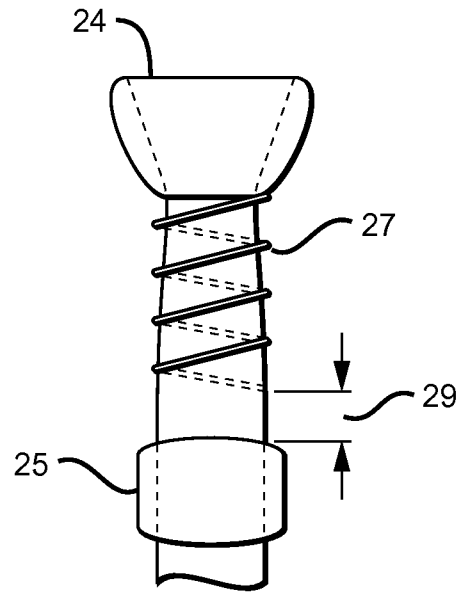


FIG. 4B

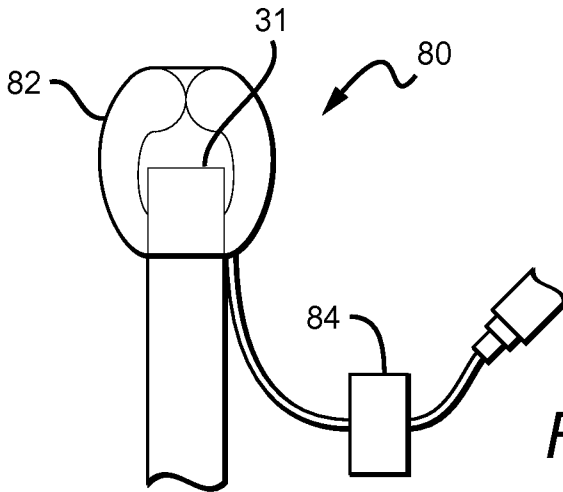


FIG. 4C

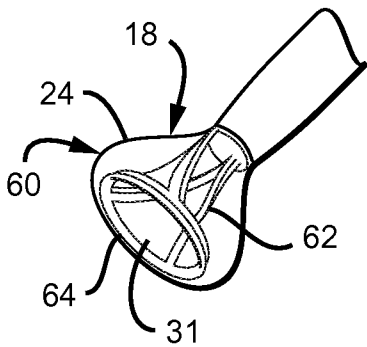


FIG. 5A

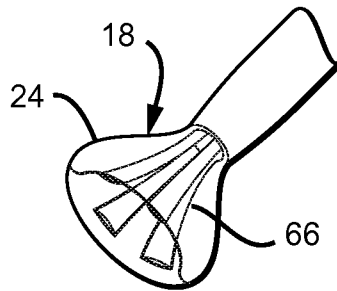


FIG. 5B

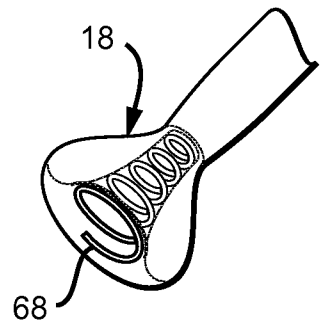
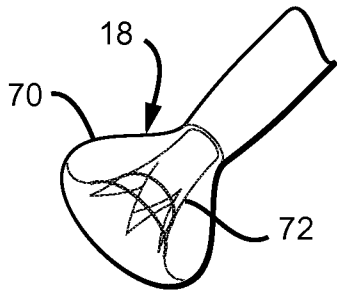
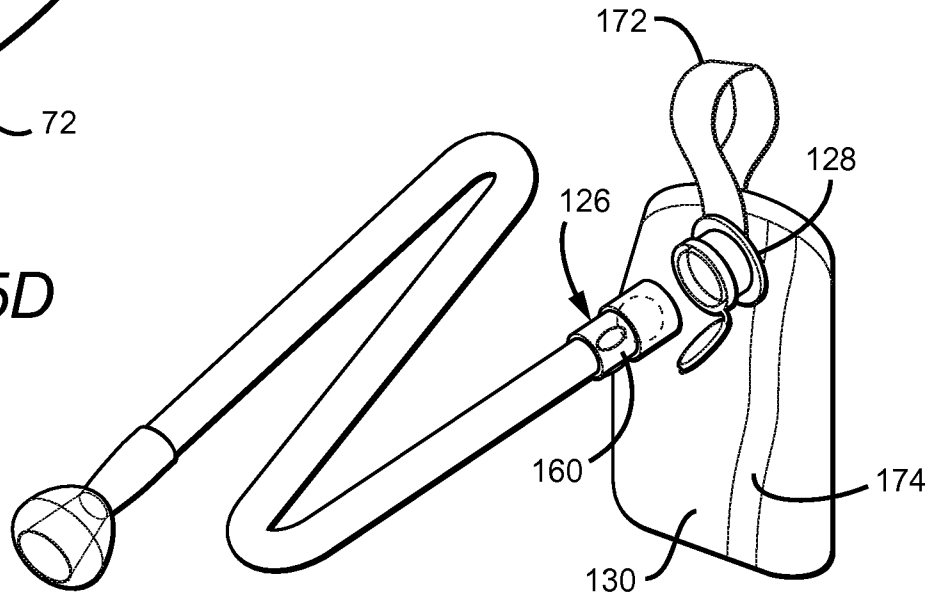


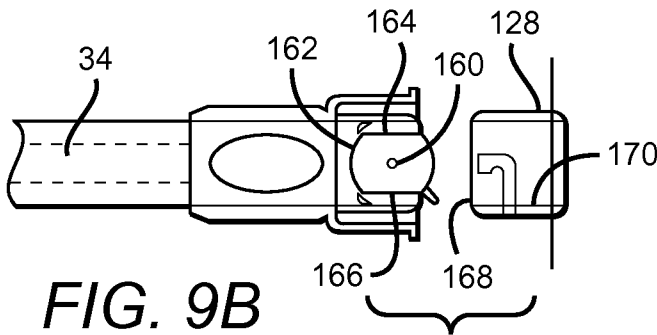
FIG. 5C



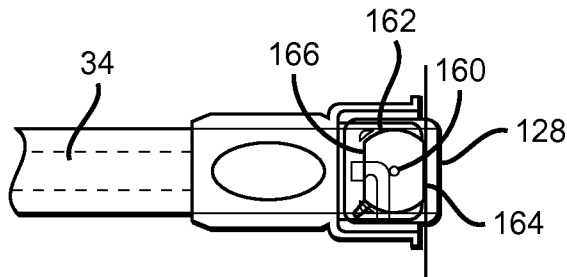
**FIG. 5D**



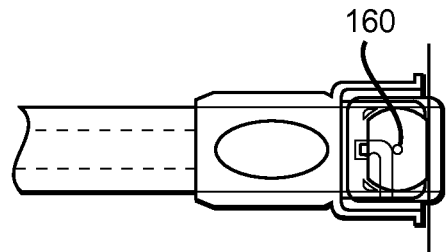
**FIG. 9A**



**FIG. 9B**



**FIG. 9C**



**FIG. 9D**

FIG. 6

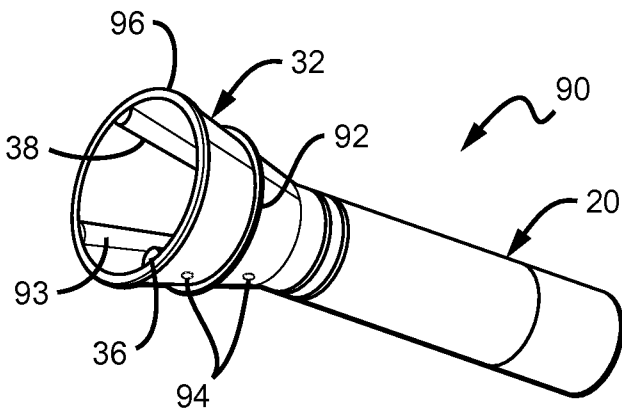
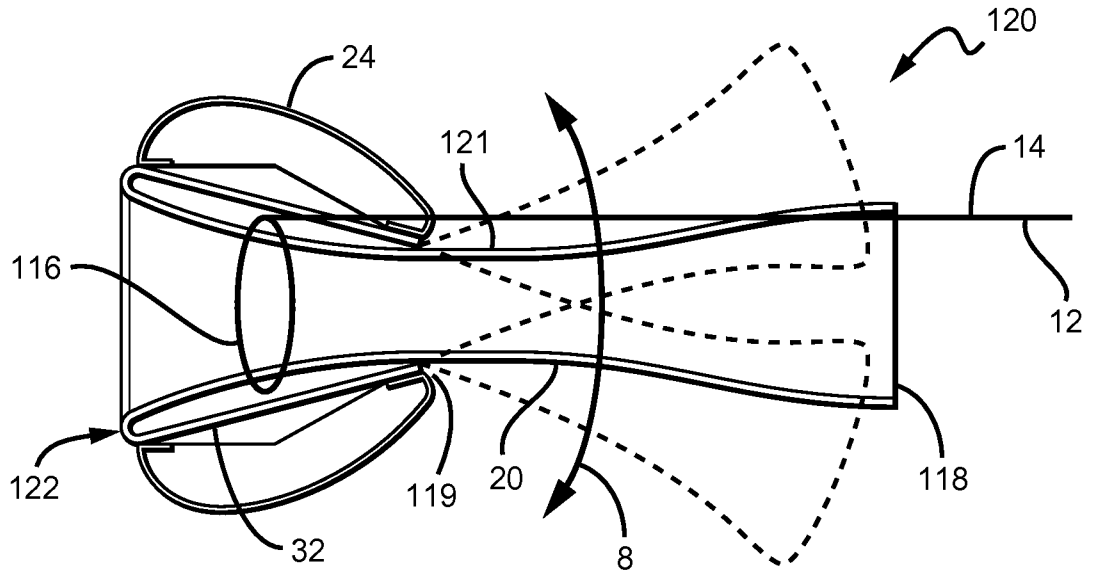


FIG. 7A

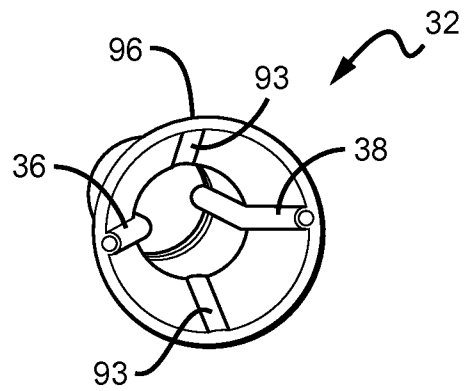


FIG. 7B

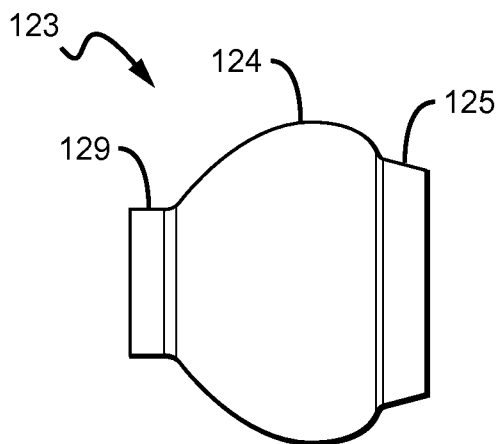


FIG. 7C

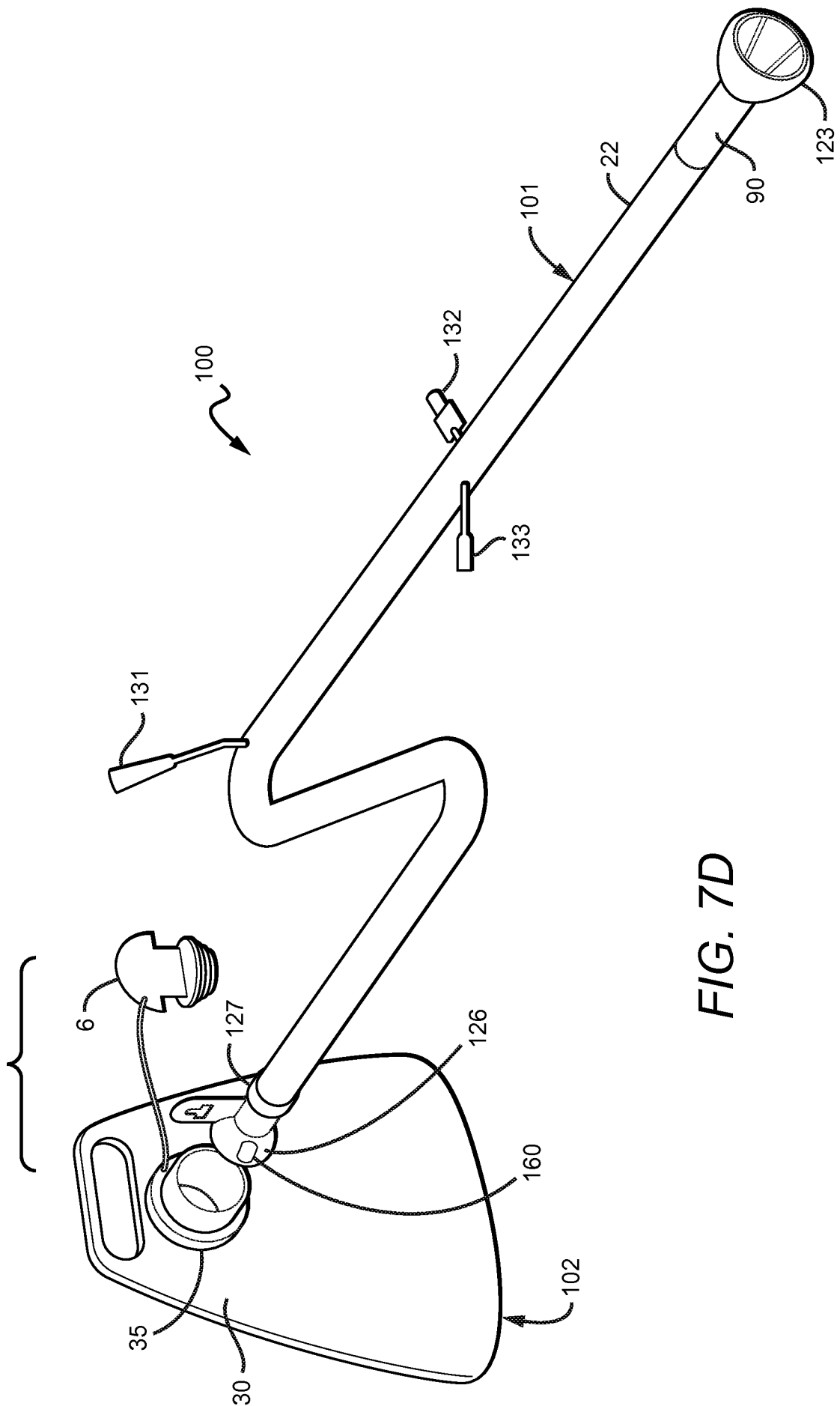


FIG. 7D

8/27

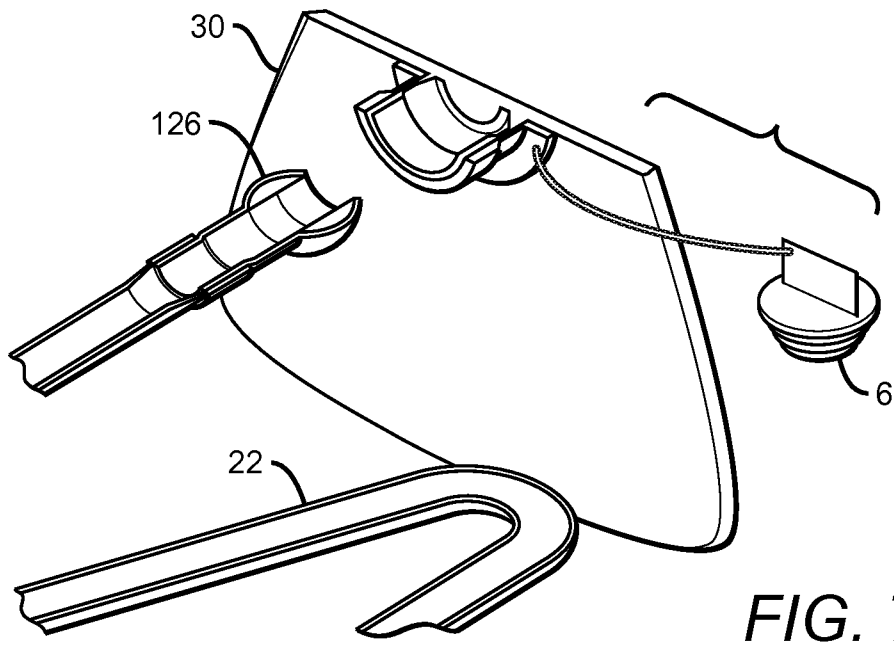


FIG. 7E

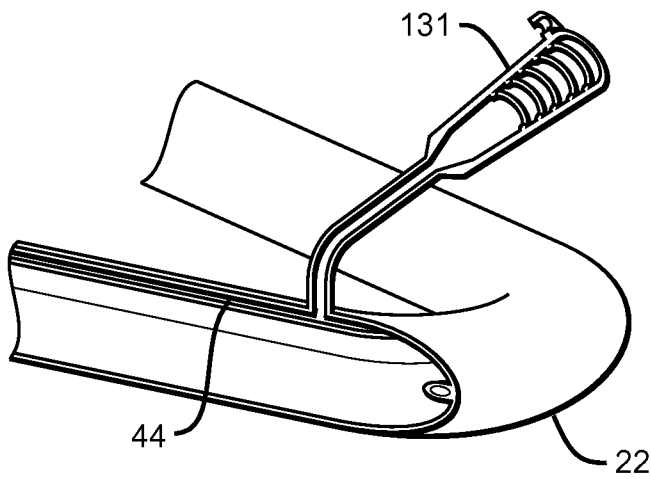


FIG. 7F

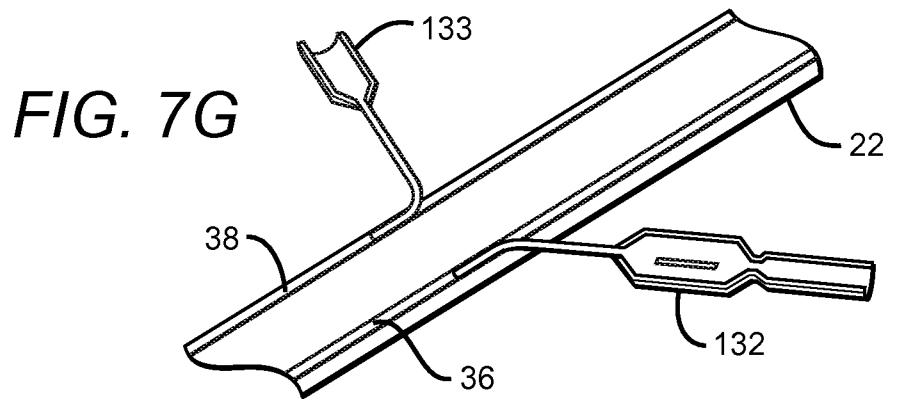


FIG. 7G

9/27

FIG. 8A

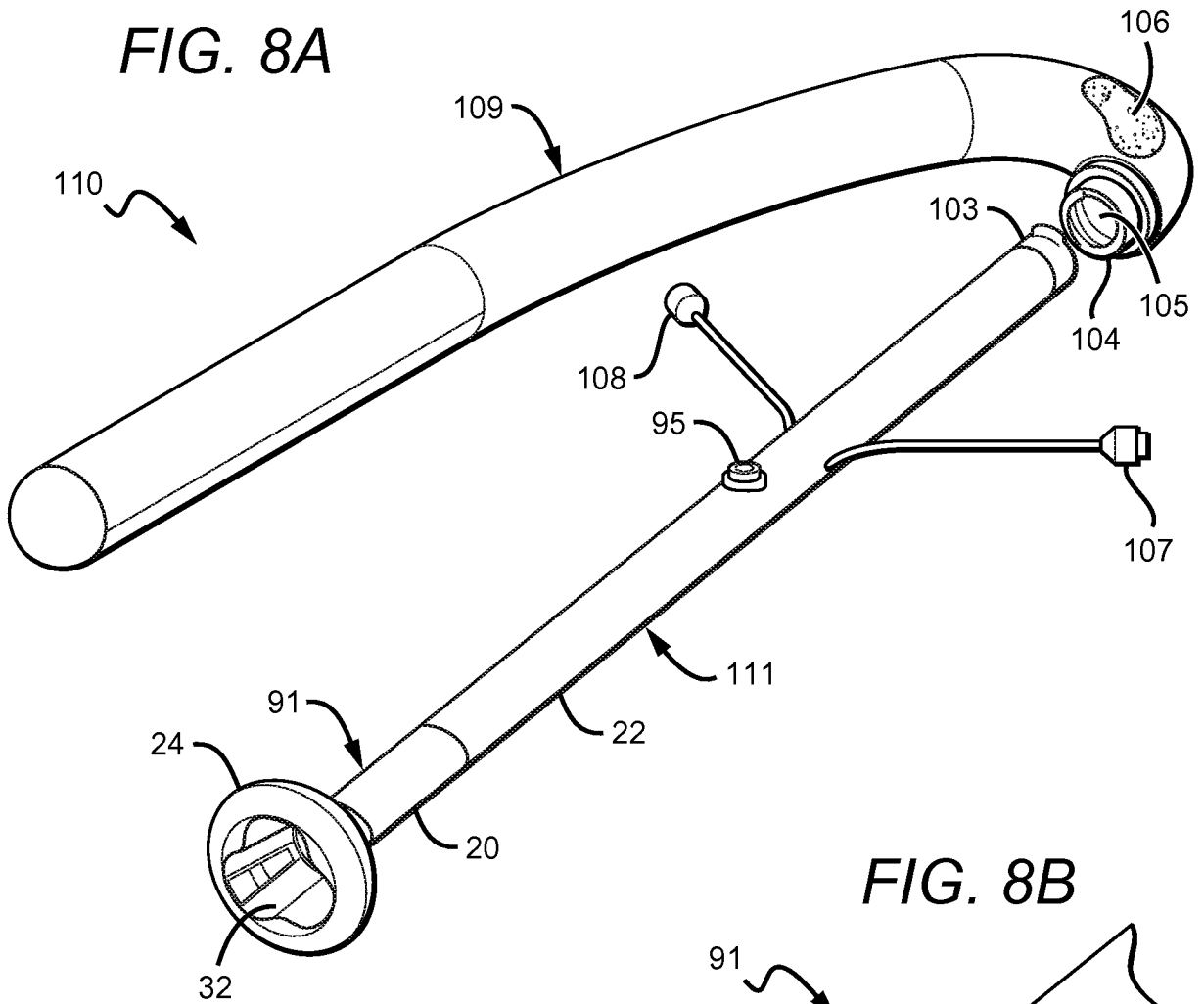


FIG. 8B

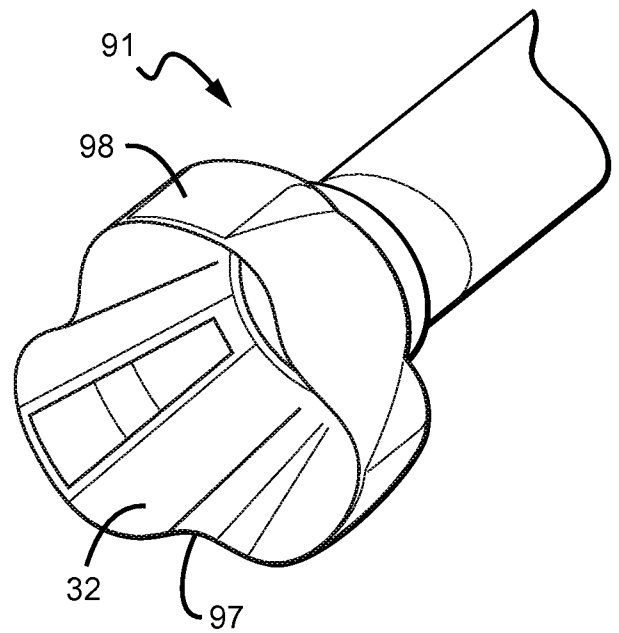


FIG. 8C

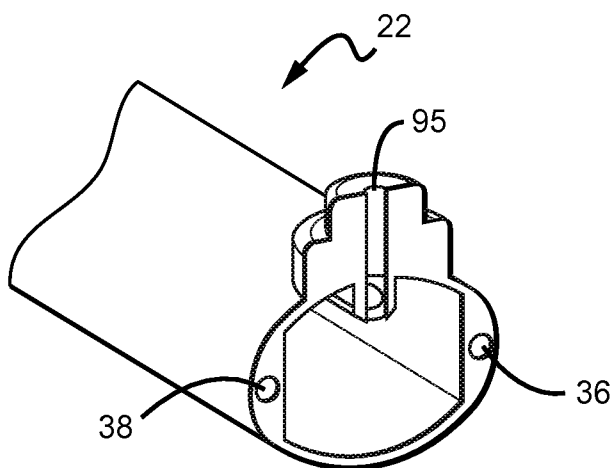




FIG. 8D

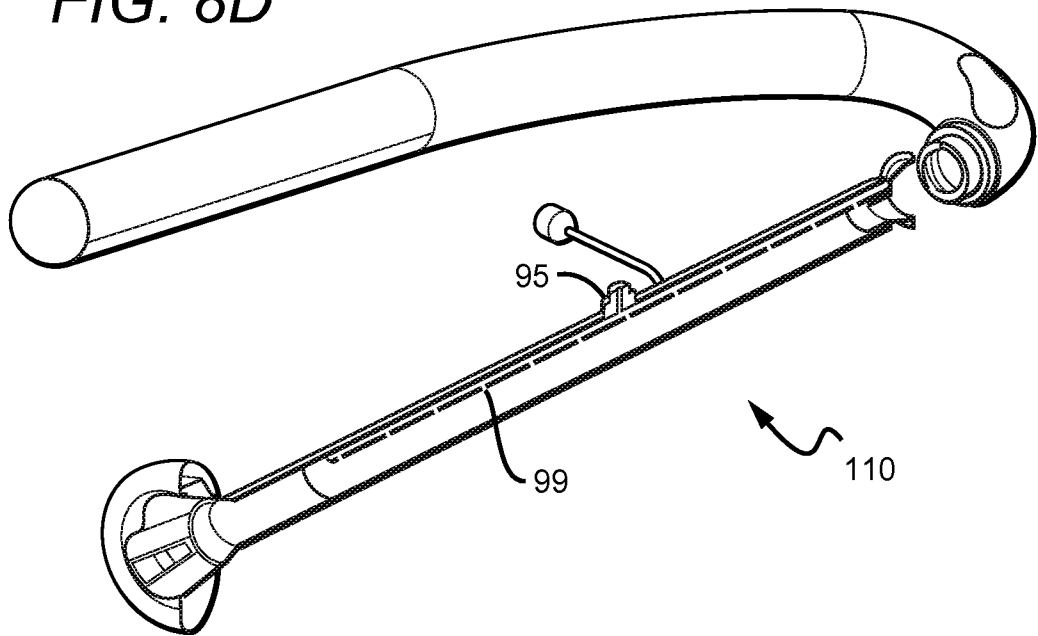
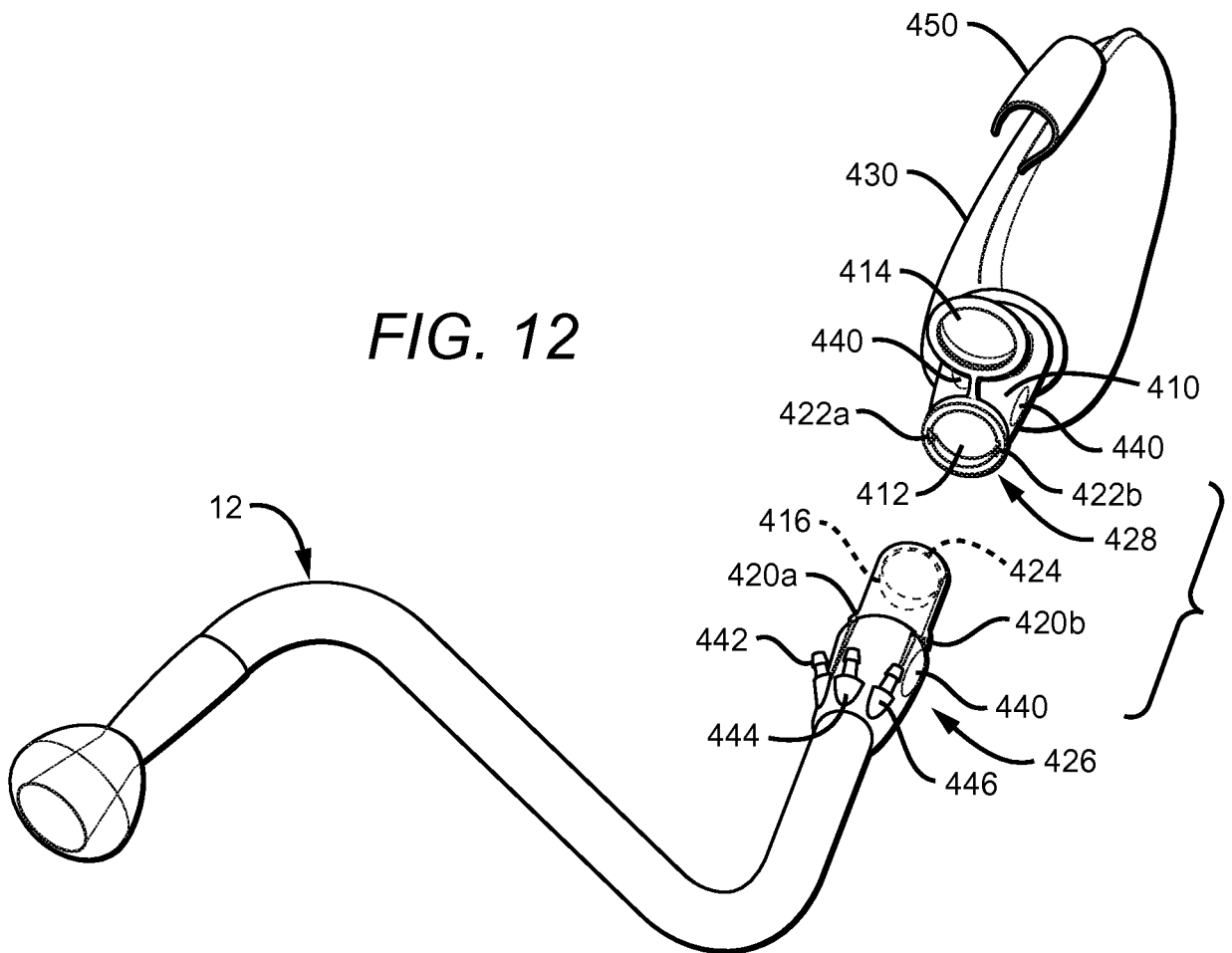
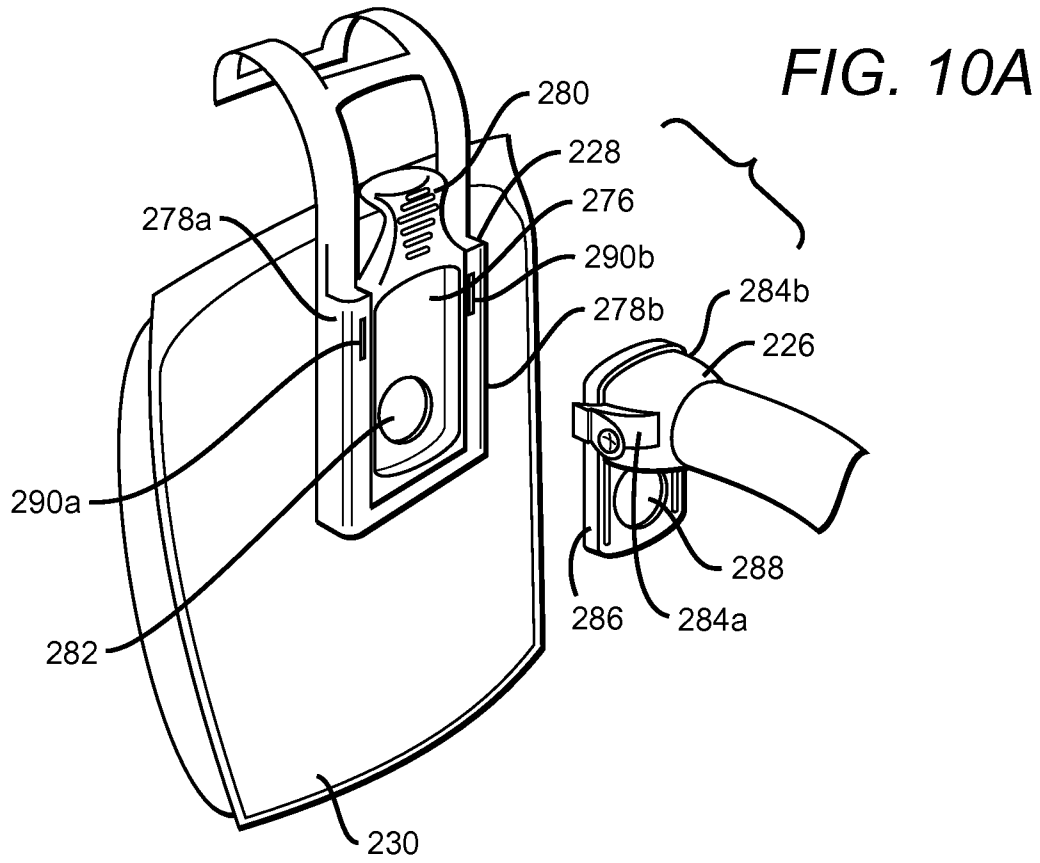
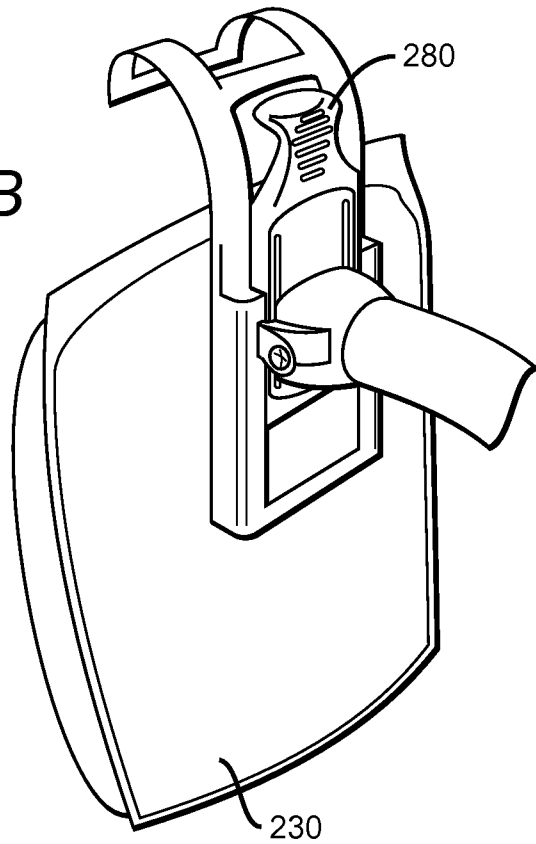


FIG. 12

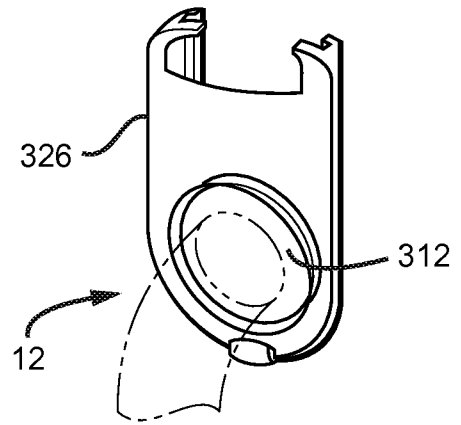
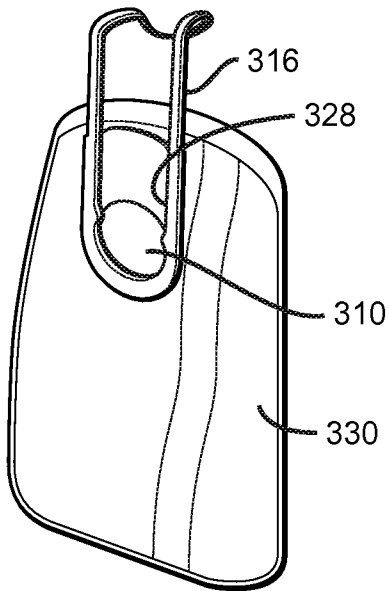




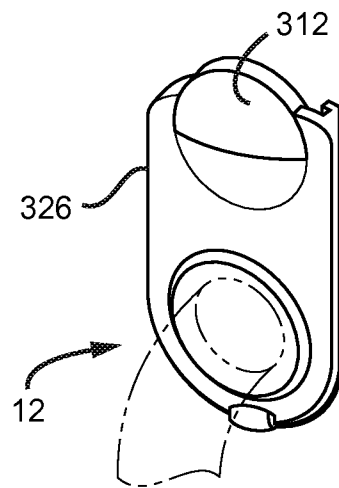
**FIG. 10B**



**FIG. 11A**

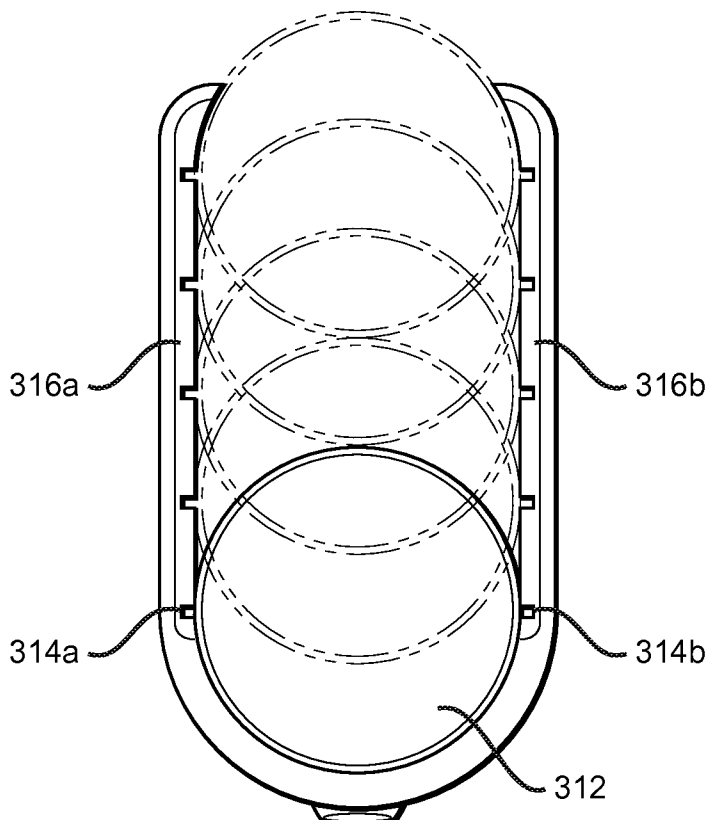


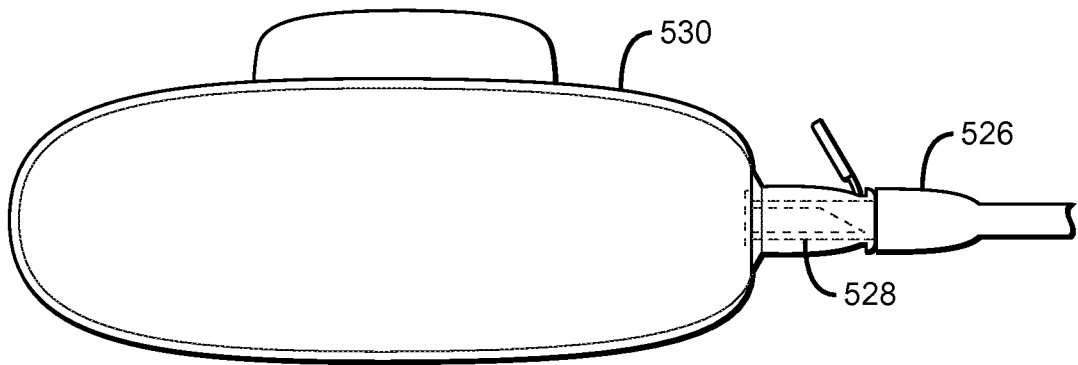
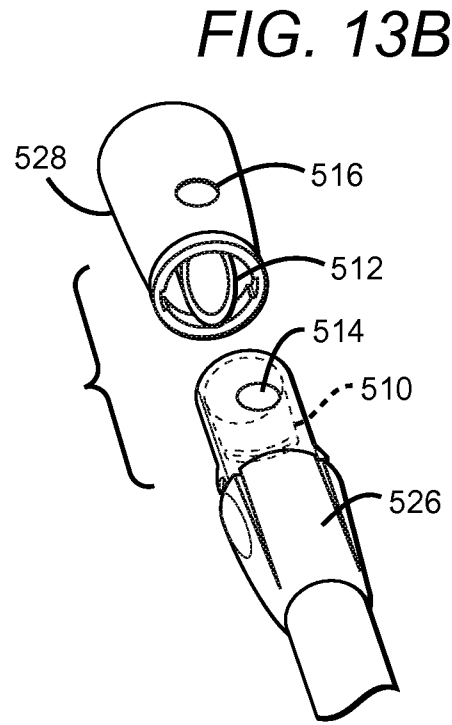
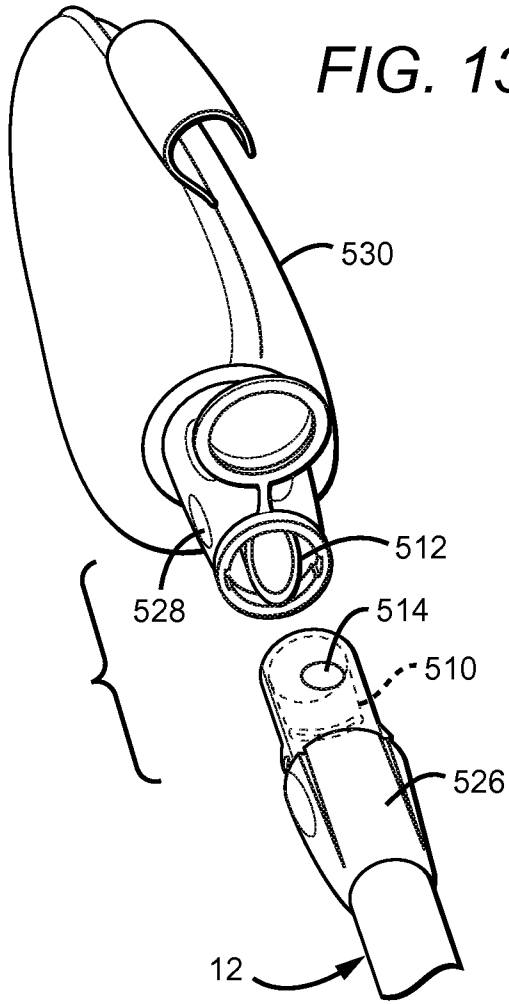
**FIG. 11B**



**FIG. 11C**

**FIG. 11D**





**FIG. 13C**

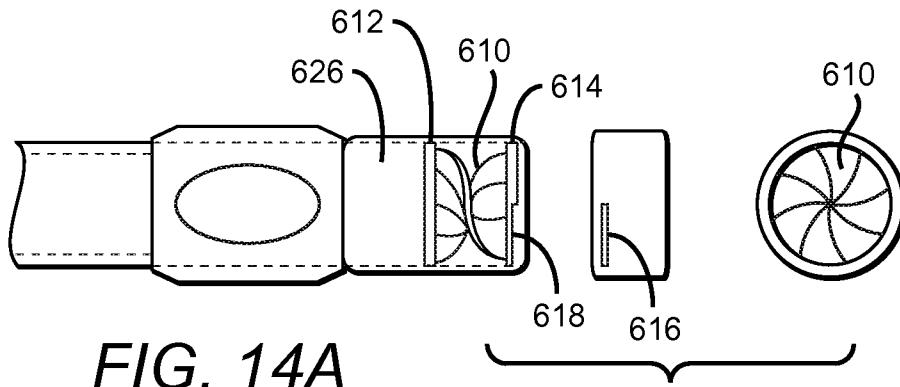


FIG. 14A

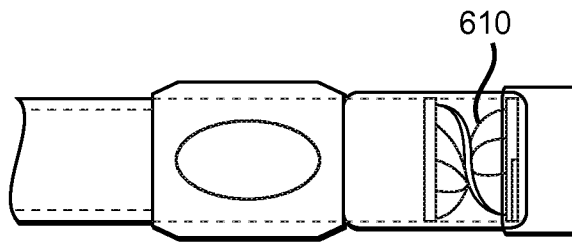


FIG. 14B

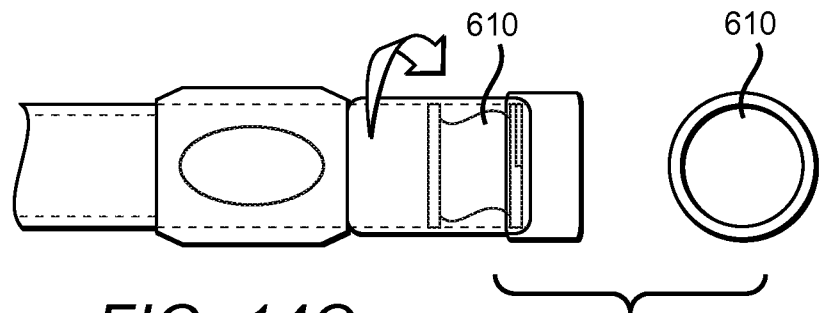


FIG. 14C

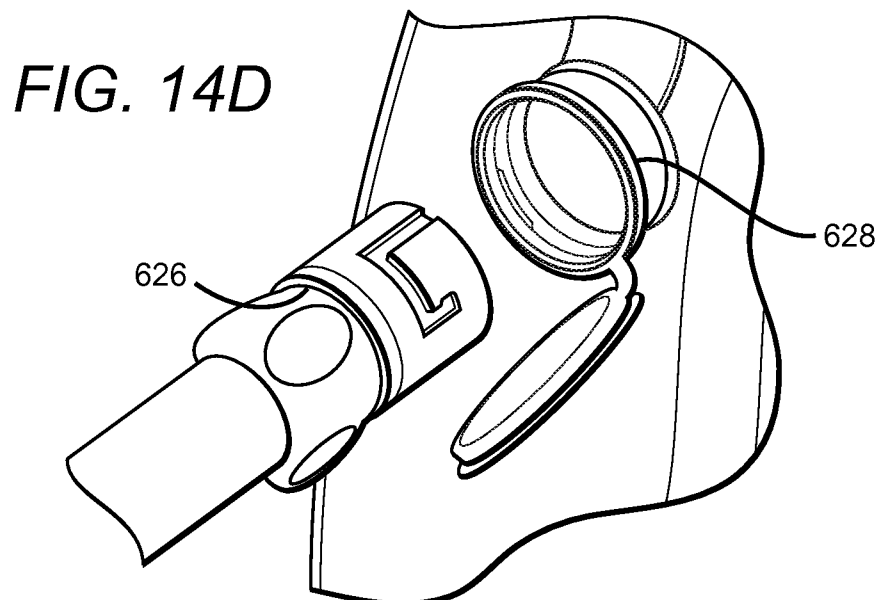
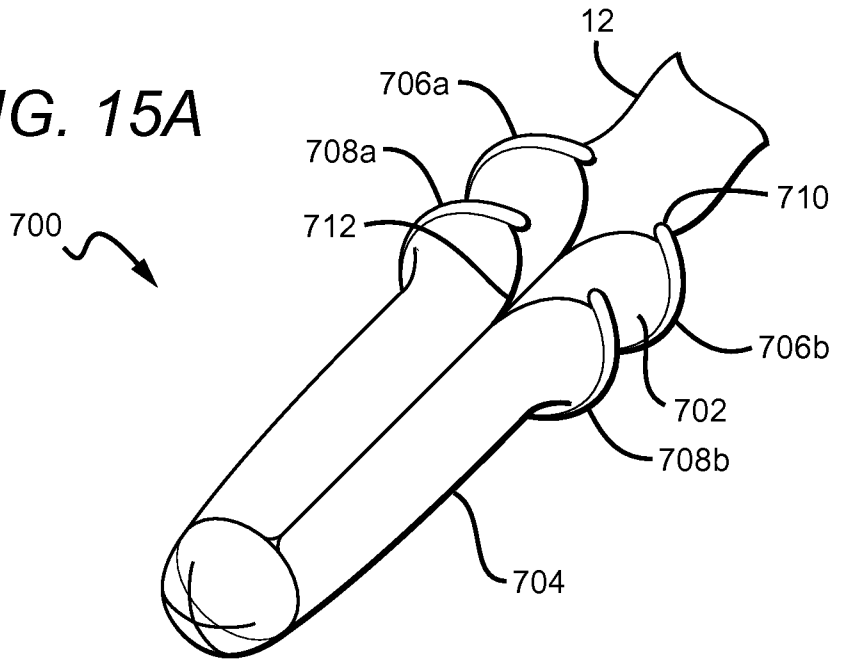
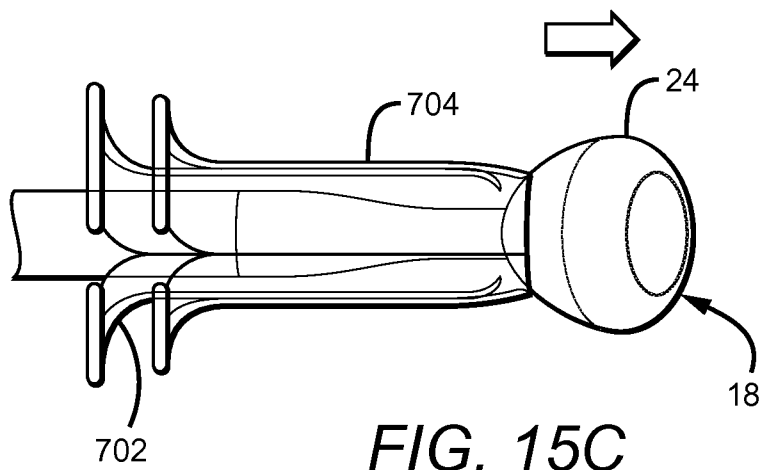
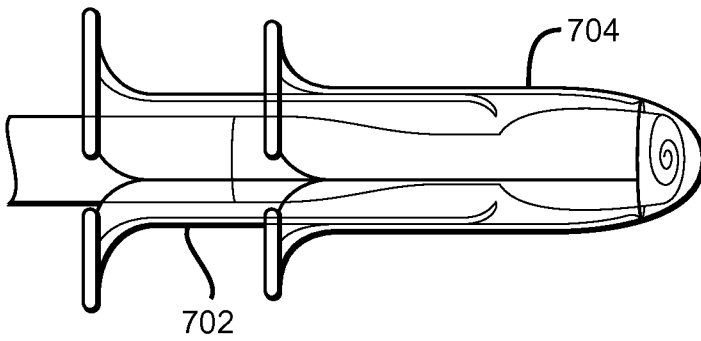


FIG. 14D

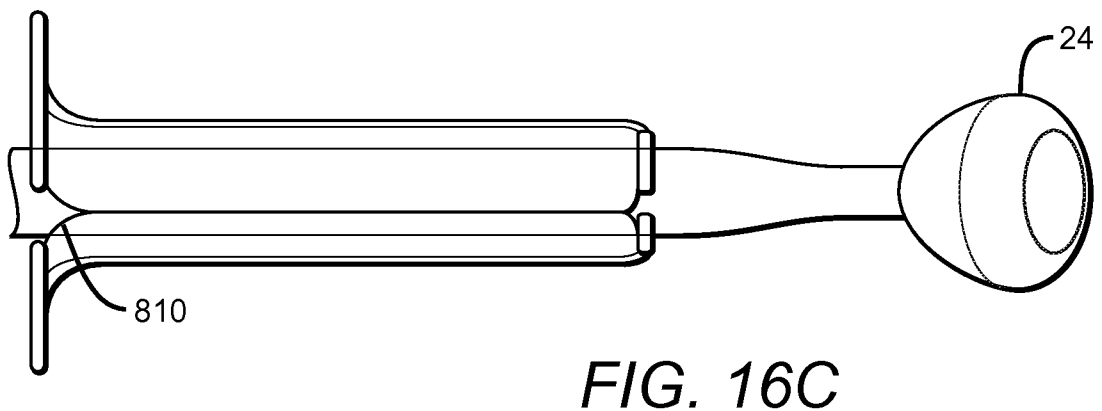
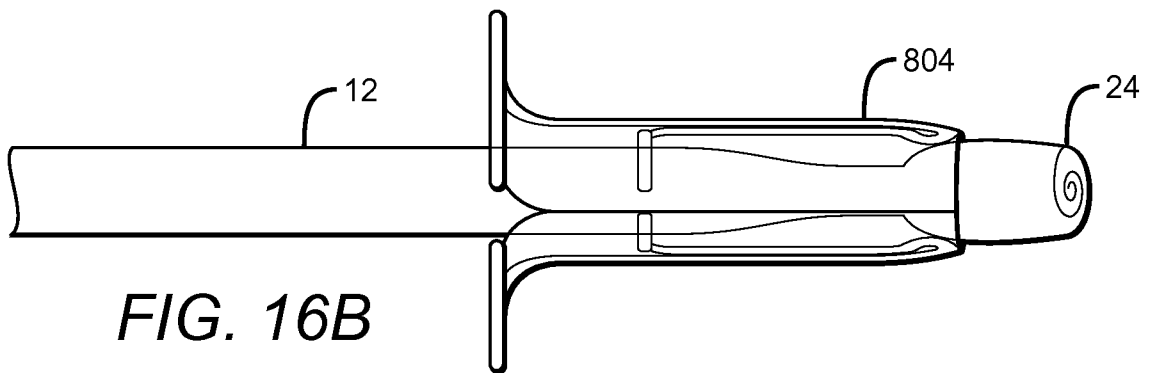
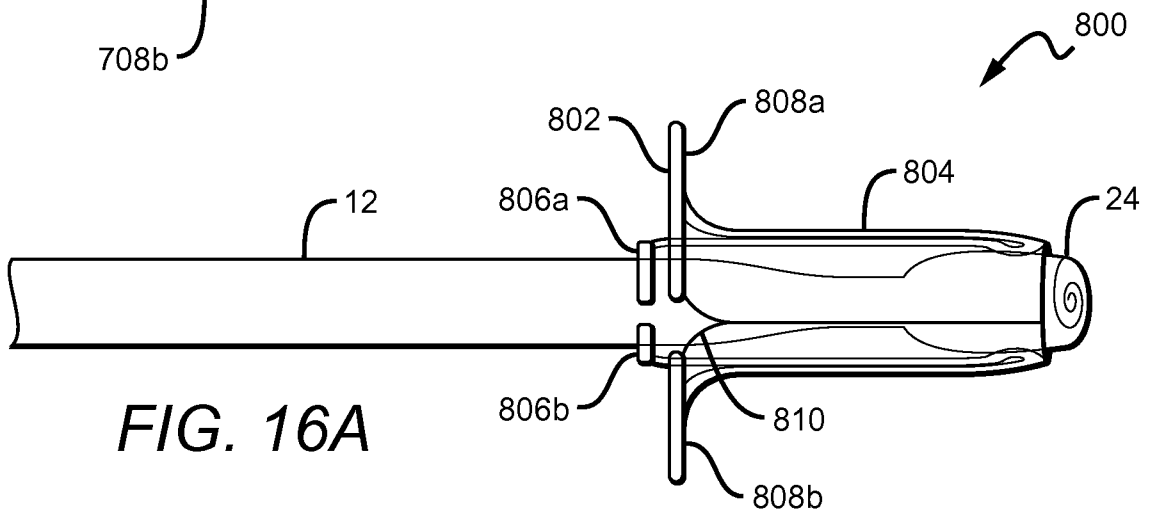
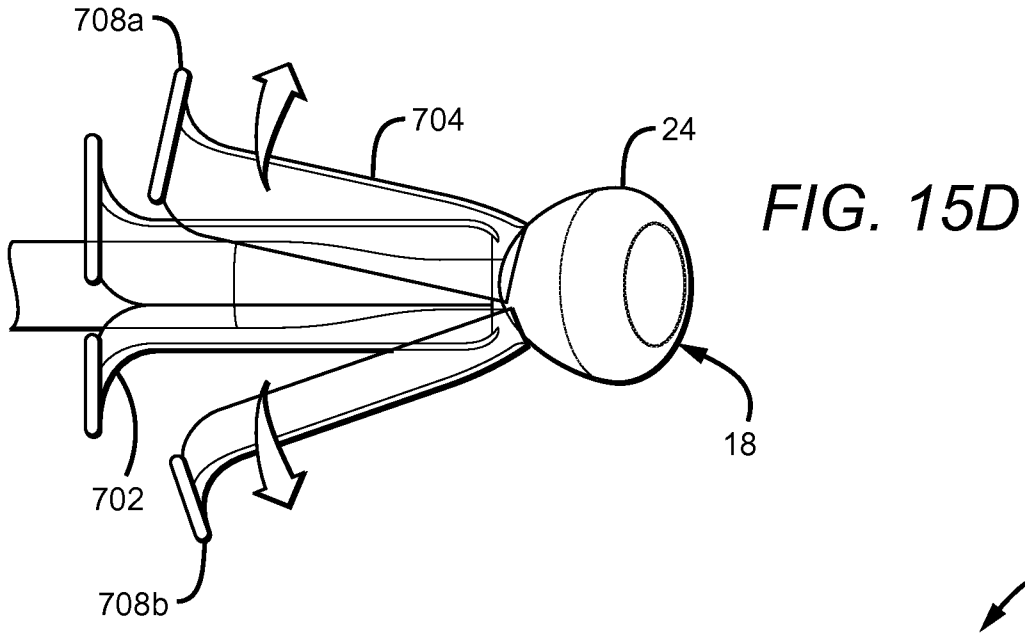
**FIG. 15A**

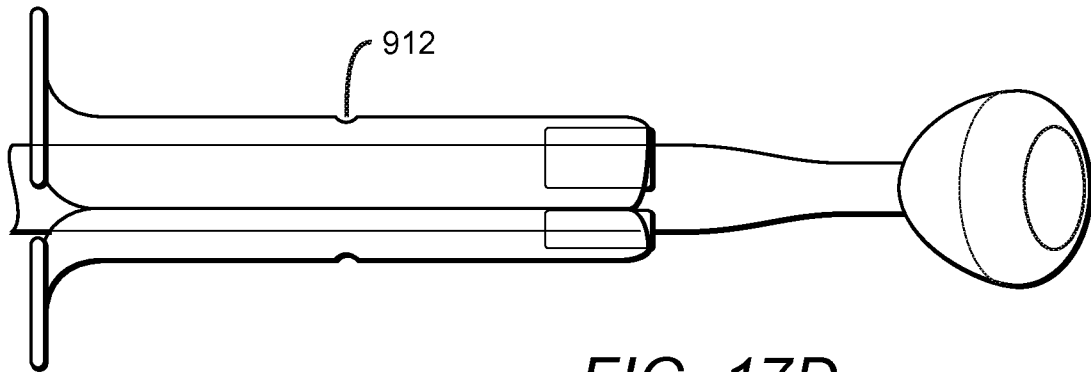
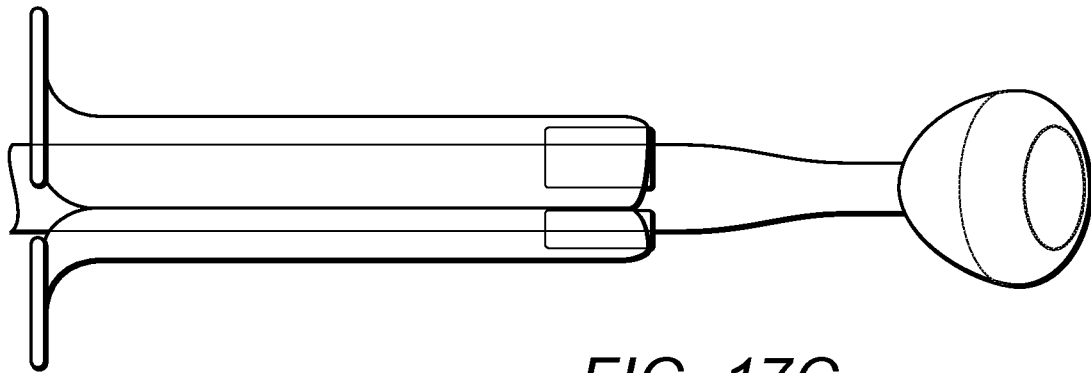
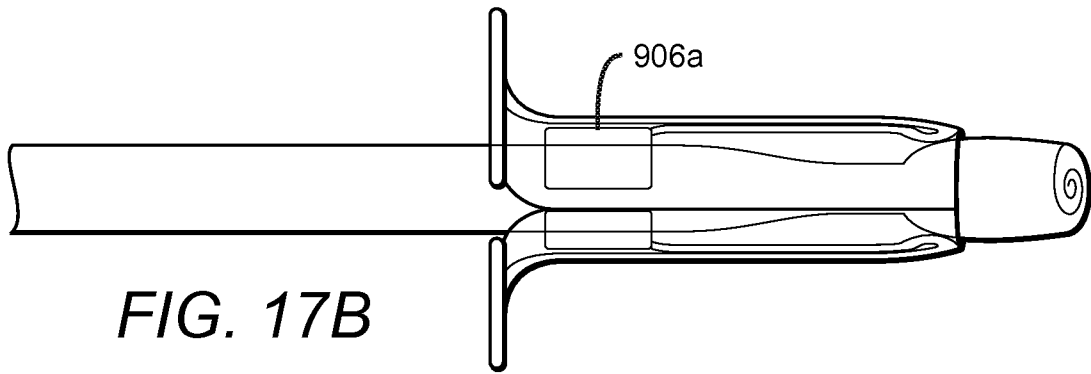
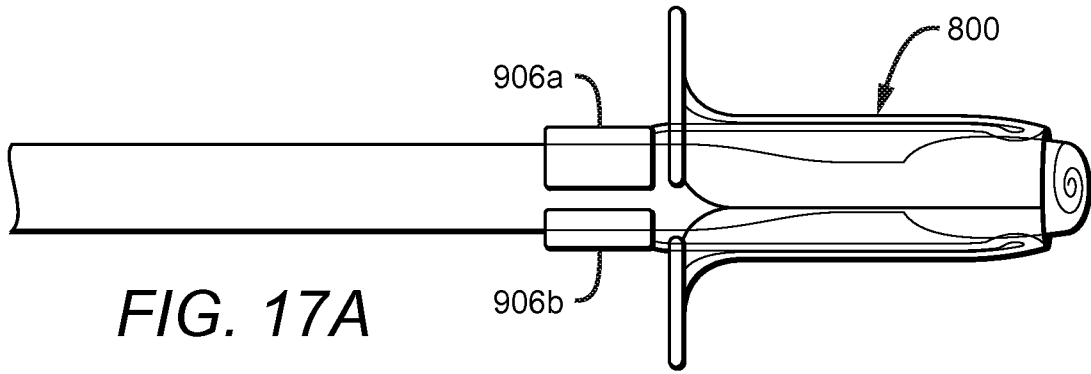


**FIG. 15B**



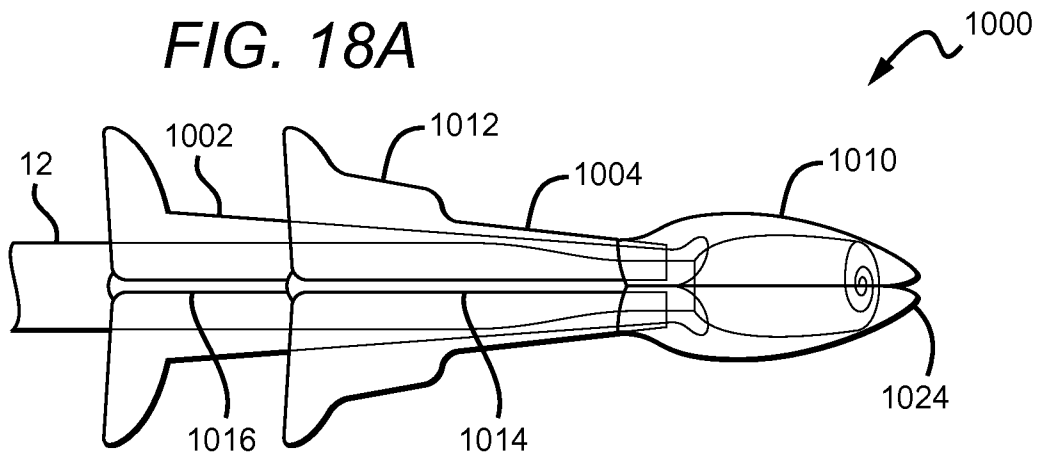
**FIG. 15C**



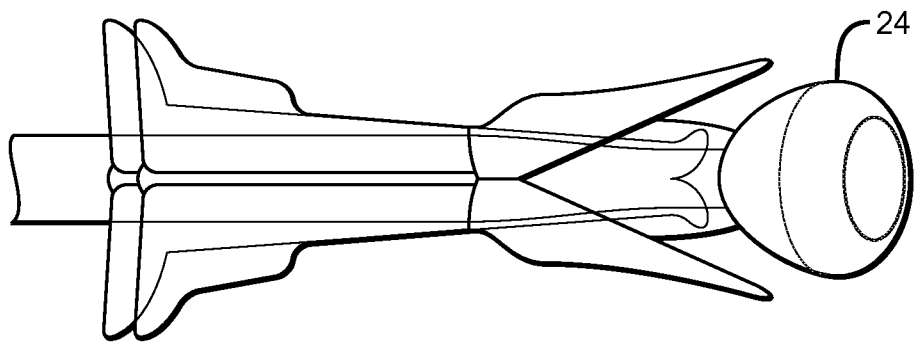




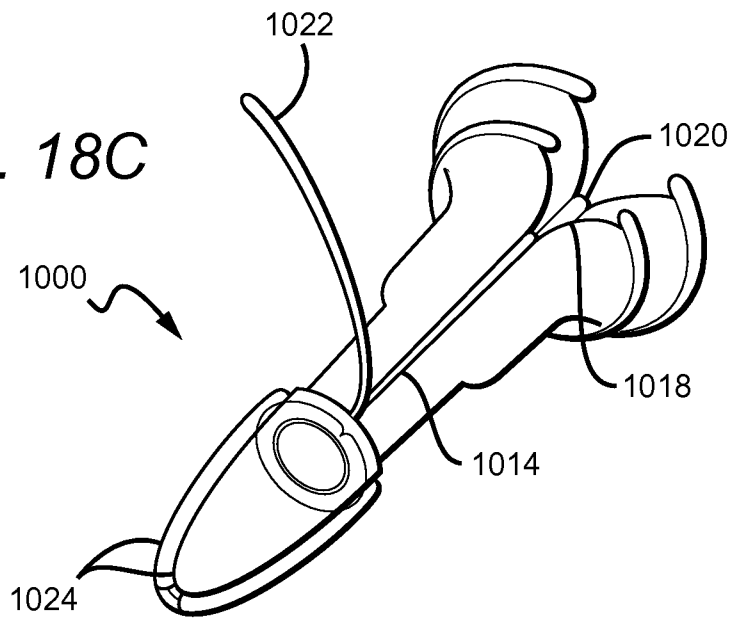
**FIG. 18A**



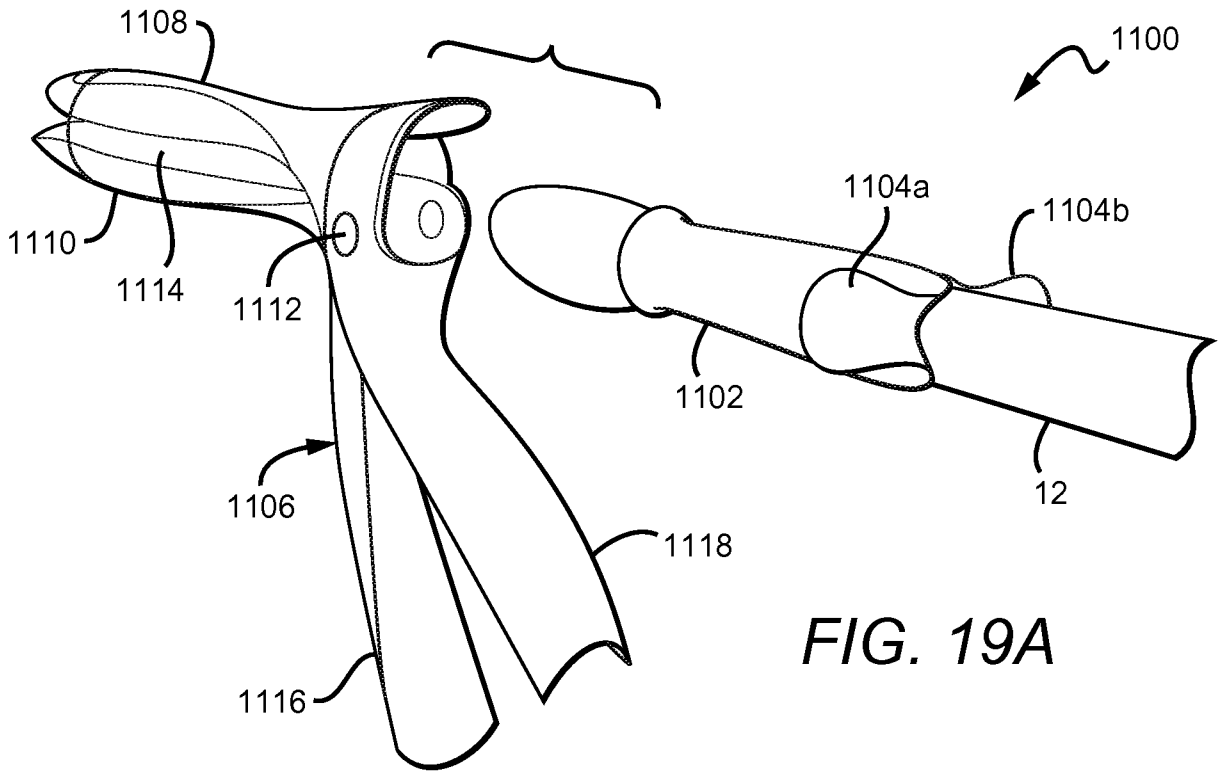
**FIG. 18B**



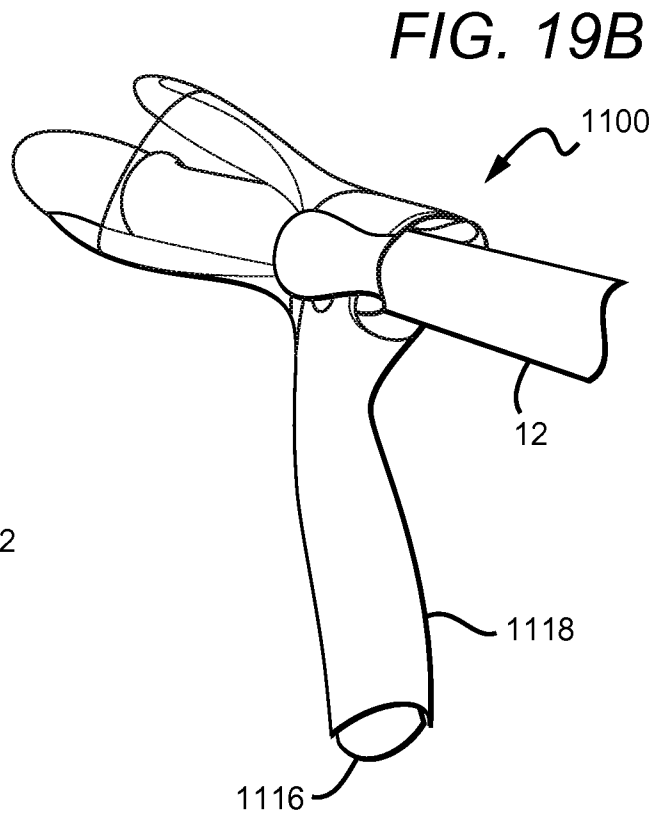
**FIG. 18C**



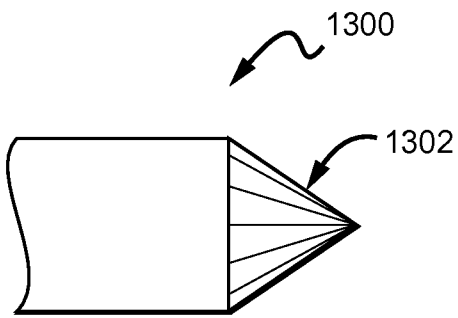
19/27



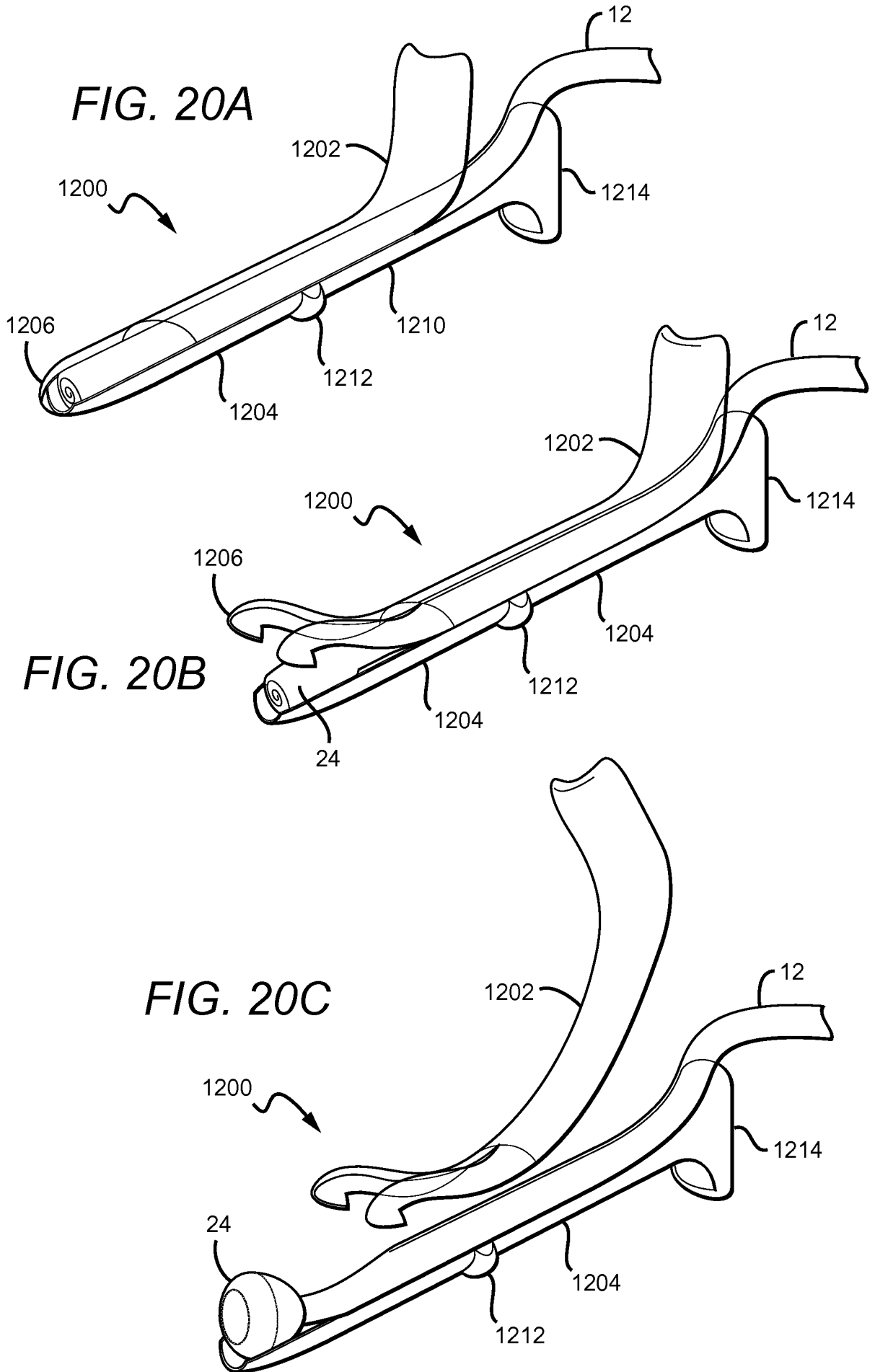
**FIG. 19A**



**FIG. 19B**



**FIG. 21**



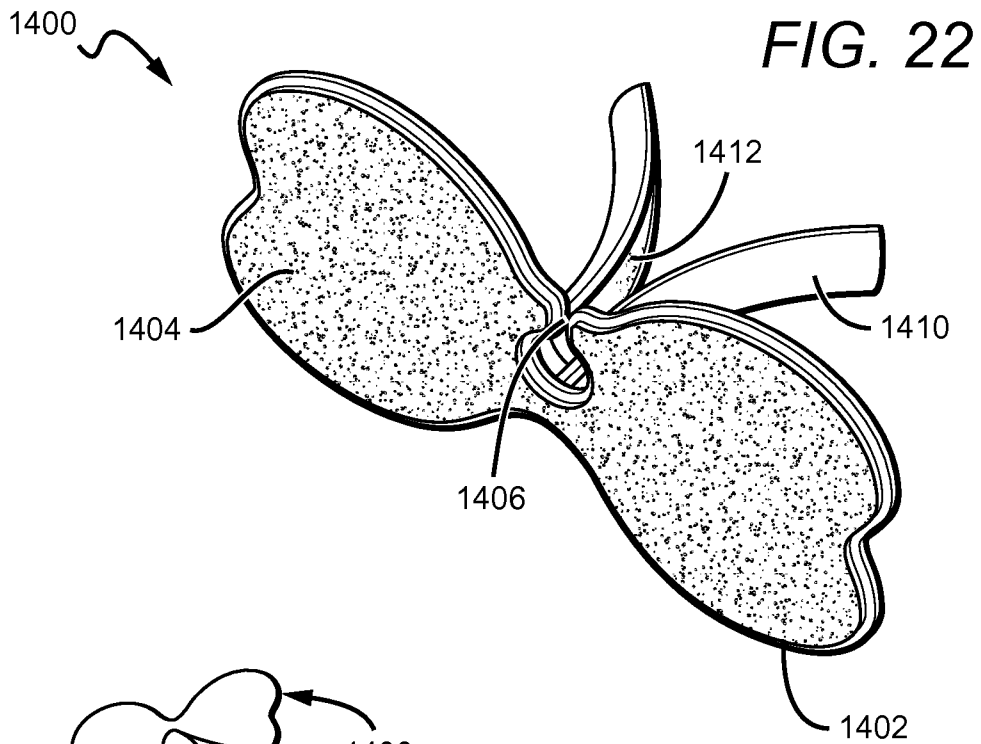


FIG. 22

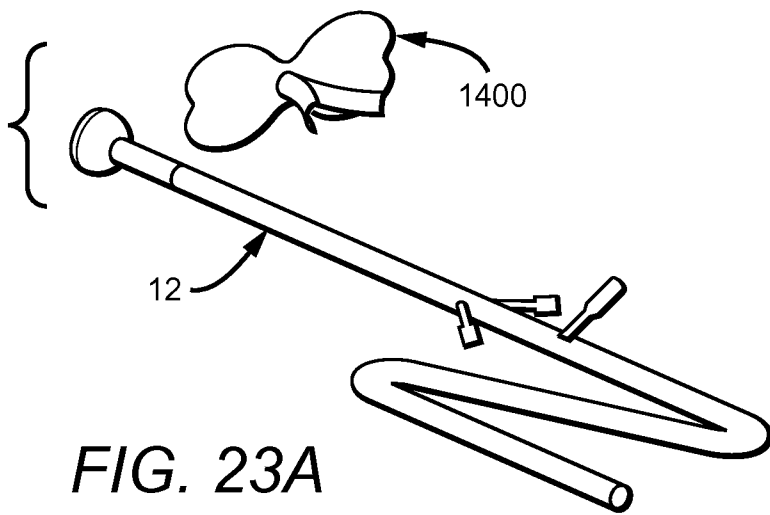


FIG. 23A

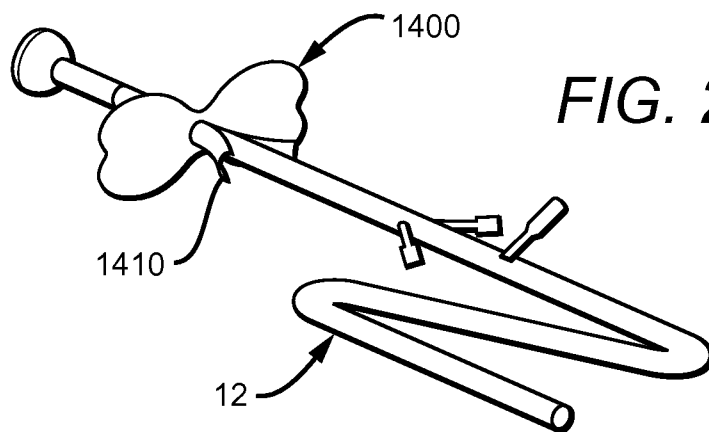


FIG. 23B

FIG. 23C

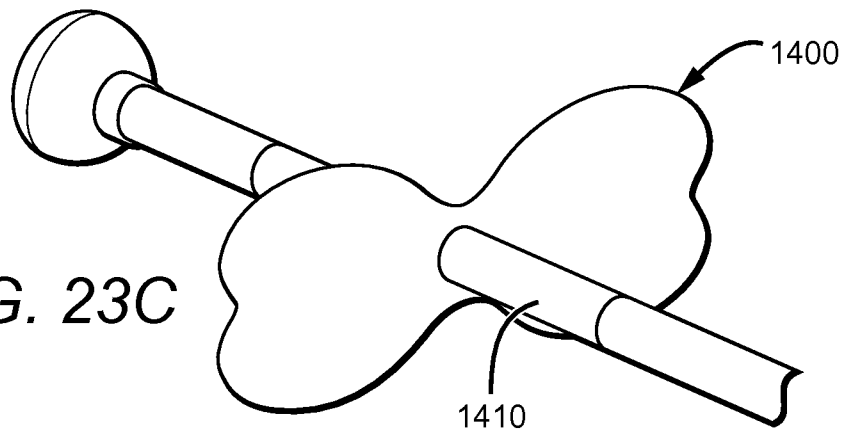


FIG. 23D

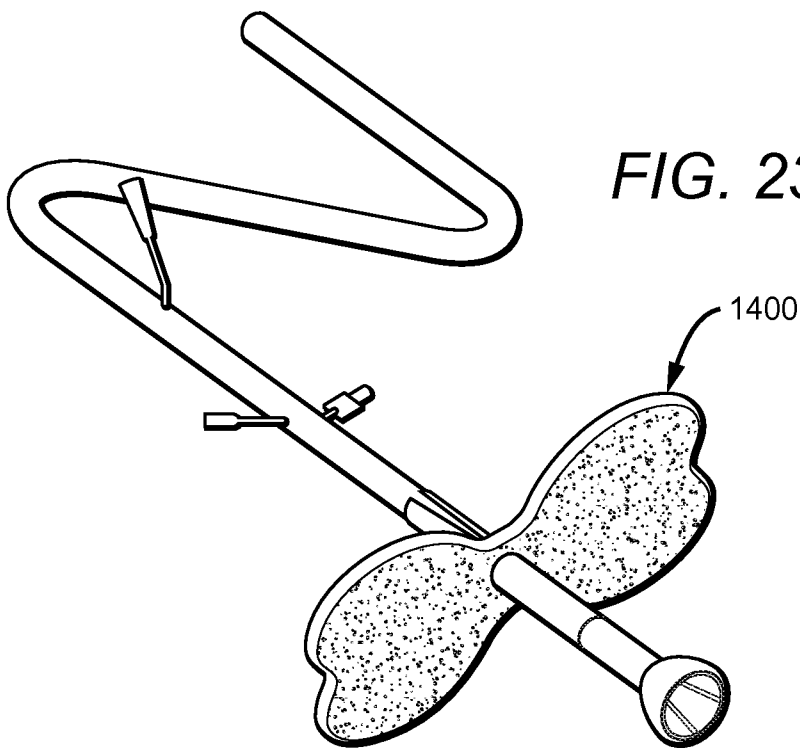
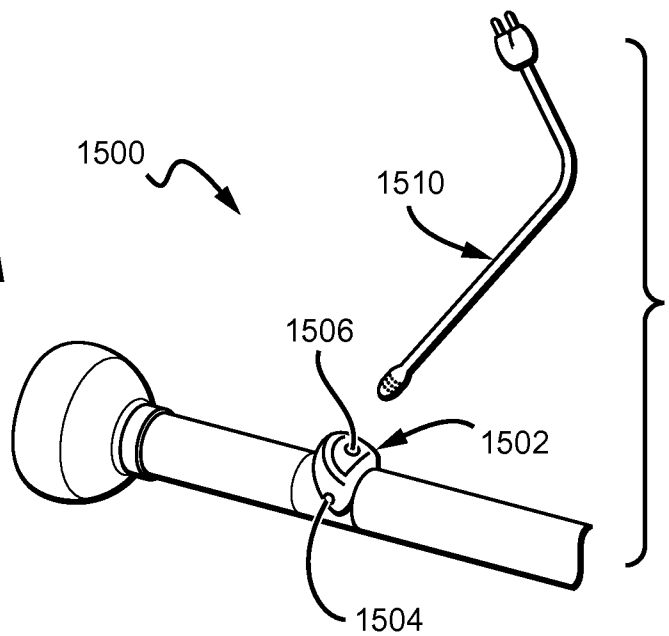


FIG. 24A



23/27

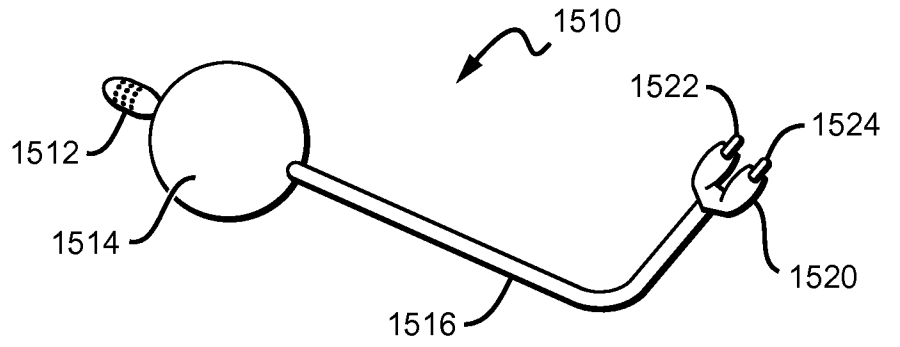


FIG. 24B

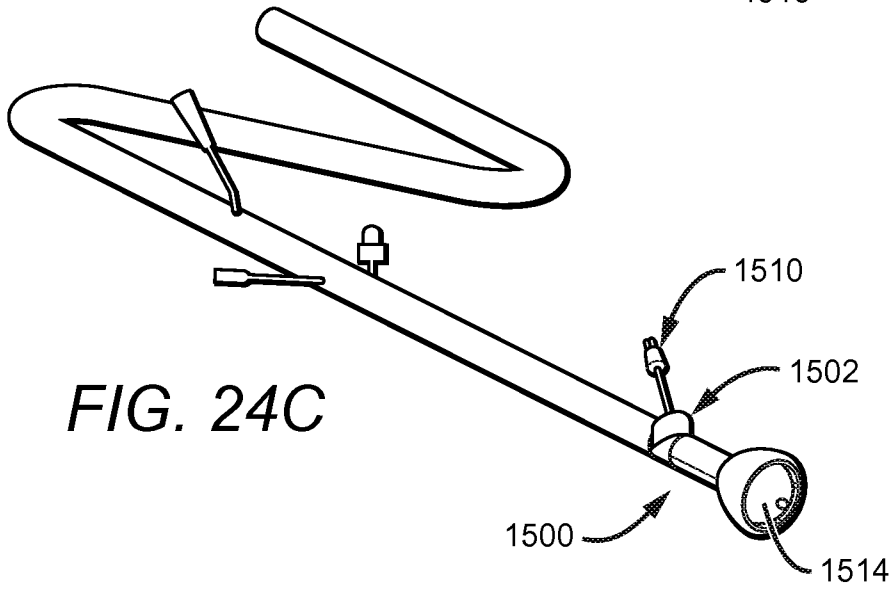


FIG. 24C

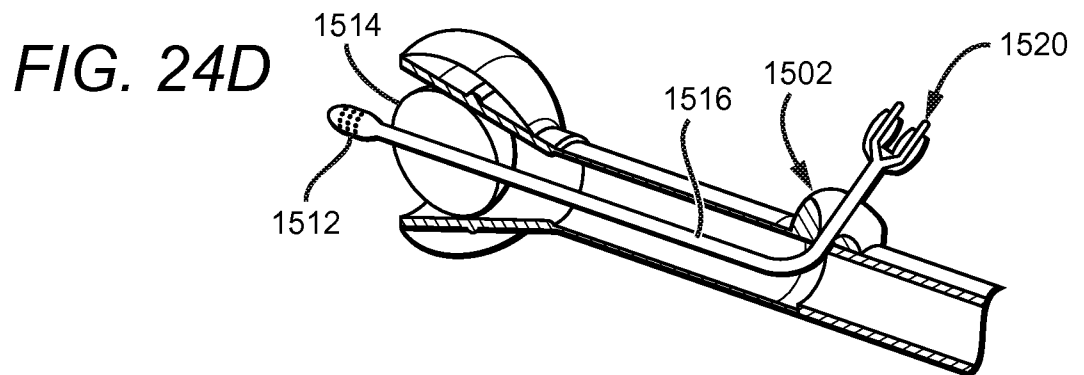


FIG. 24D

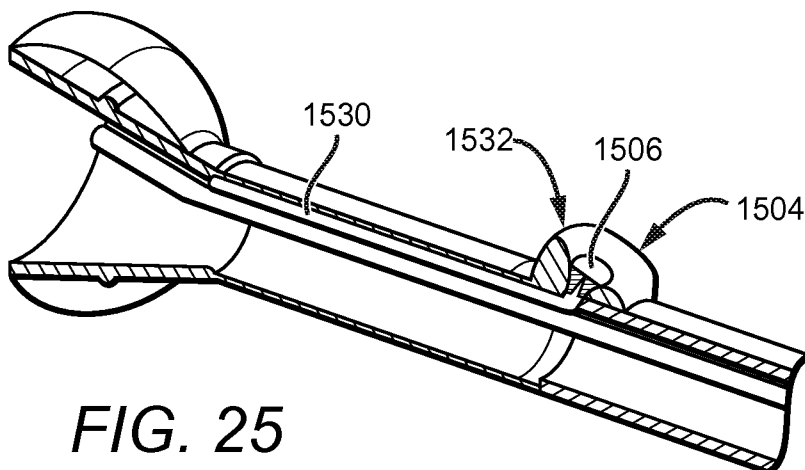


FIG. 25



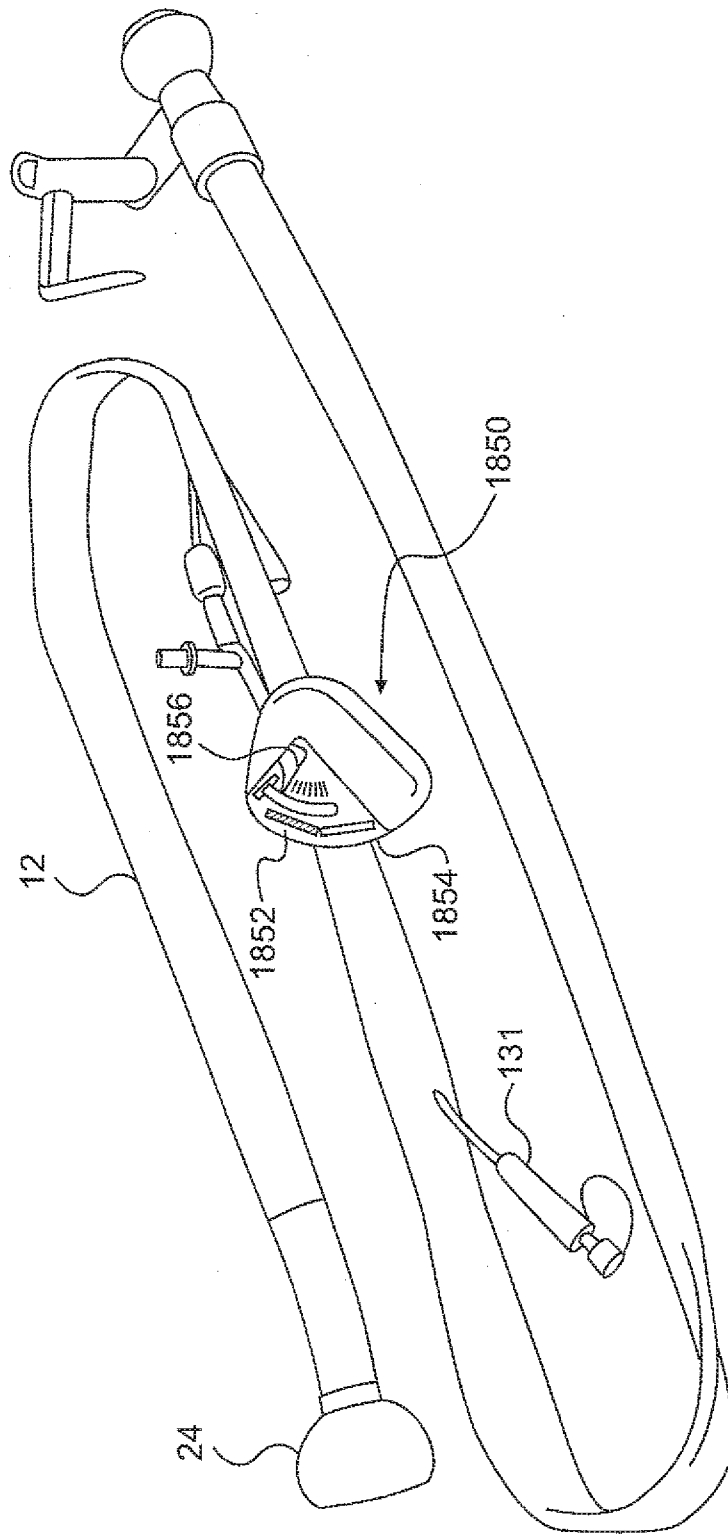
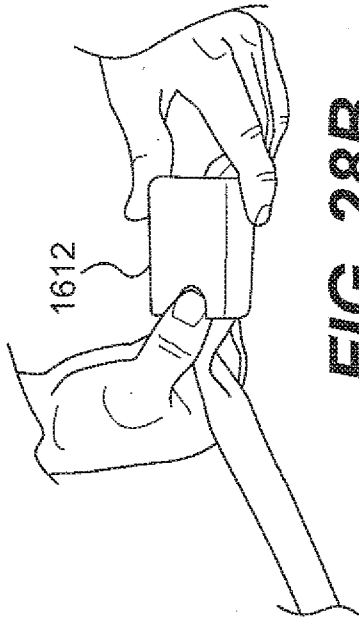
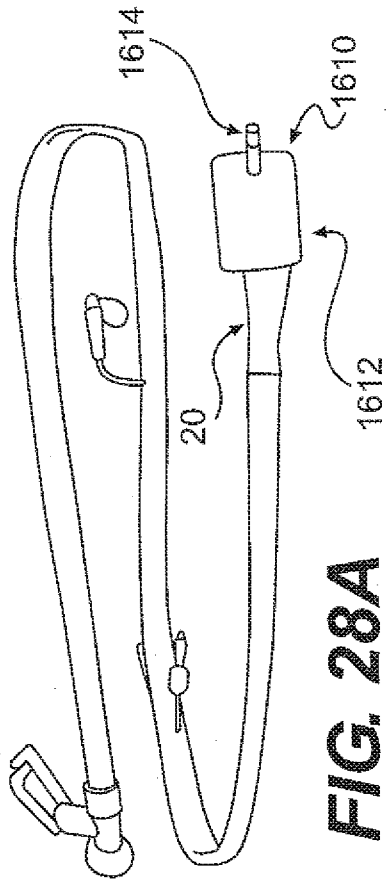


FIG. 27

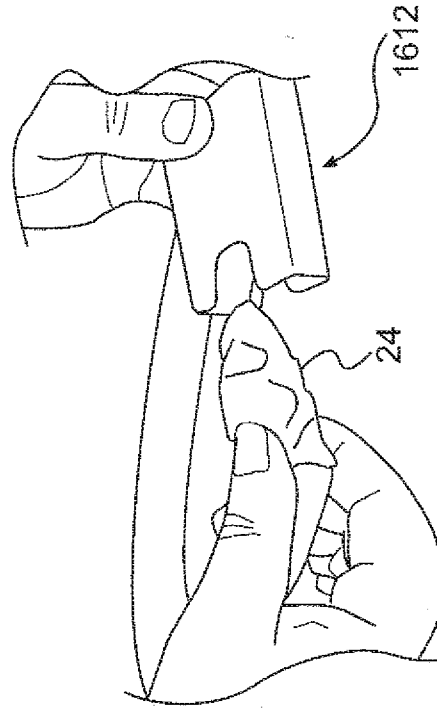




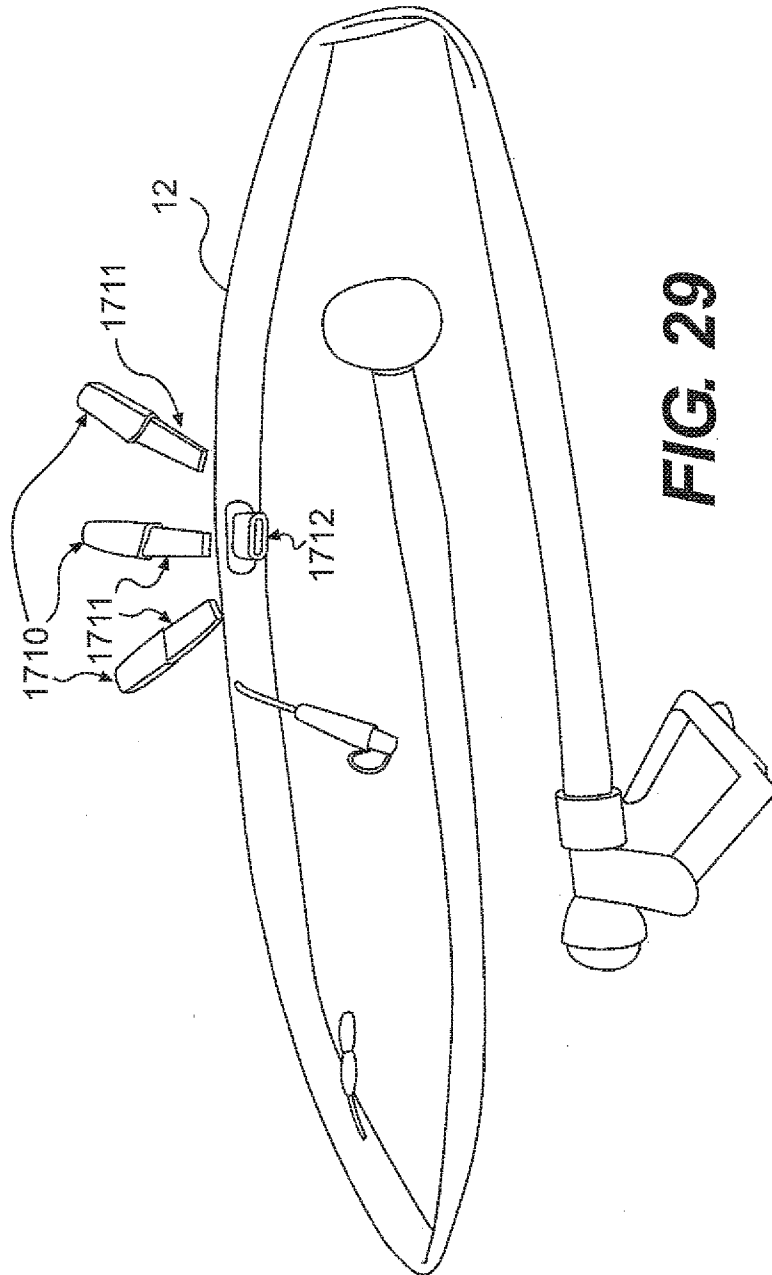
**FIG. 28B**



**FIG. 28A**



**FIG. 28C**



**FIG. 29**

**INTERNATIONAL SEARCH REPORT**

International application No.  
PCT/US2009/064846

<p><b>A. CLASSIFICATION OF SUBJECT MATTER</b>                  IPC(8) - A61M 1/00 (2010.01)                  USPC - 604/317                  According to International Patent Classification (IPC) or to both national classification and IPC</p>																										
<p><b>B. FIELDS SEARCHED</b></p> <p>Minimum documentation searched (classification system followed by classification symbols)                  IPC(8) - A61M 1/00 (2010.01)                  USPC - 604/96.01, 264, 317</p> <p>Documentation searched other than minimum documentation to the extent that such documents are included in the fields searched</p> <p>Electronic data base consulted during the international search (name of data base and, where practicable, search terms used)                  PatBase</p>																										
<p><b>C. DOCUMENTS CONSIDERED TO BE RELEVANT</b></p> <table border="1"> <thead> <tr> <th>Category*</th> <th>Citation of document, with indication, where appropriate, of the relevant passages</th> <th>Relevant to claim No.</th> </tr> </thead> <tbody> <tr> <td>X - Y</td> <td>US 2004/0039348 A1 (KIM et al) 26 February 2004 (26.02.2004) entire document</td> <td>11 ----- 1-10, 12, 13</td> </tr> <tr> <td>Y</td> <td>US 2006/0276746 A1 (BURNSIDE et al) 07 December 2006 (07.12.2006) entire document</td> <td>1-5</td> </tr> <tr> <td>Y</td> <td>US 5,284,480 A (PORTER et al) 08 February 1994 (08.02.1994) entire document</td> <td>1-5</td> </tr> <tr> <td>Y</td> <td>WO 01/97740 A2 (MAES) 27 December 2001 (27.12.2001) entire document</td> <td>6-10</td> </tr> <tr> <td>Y</td> <td>US 5,370,624 A (EDWARDS et al) 06 December 1994 (06.12.1994) entire document</td> <td>8-10</td> </tr> <tr> <td>Y</td> <td>US 2002/0072789 A1 (HACKETT et al) 13 June 2002 (13.06.2002) entire document</td> <td>10</td> </tr> <tr> <td>Y</td> <td>US 5,100,626 A (LEVIN) 31 March 1992 (31.03.1992) entire document</td> <td>12, 13</td> </tr> </tbody> </table>			Category*	Citation of document, with indication, where appropriate, of the relevant passages	Relevant to claim No.	X - Y	US 2004/0039348 A1 (KIM et al) 26 February 2004 (26.02.2004) entire document	11 ----- 1-10, 12, 13	Y	US 2006/0276746 A1 (BURNSIDE et al) 07 December 2006 (07.12.2006) entire document	1-5	Y	US 5,284,480 A (PORTER et al) 08 February 1994 (08.02.1994) entire document	1-5	Y	WO 01/97740 A2 (MAES) 27 December 2001 (27.12.2001) entire document	6-10	Y	US 5,370,624 A (EDWARDS et al) 06 December 1994 (06.12.1994) entire document	8-10	Y	US 2002/0072789 A1 (HACKETT et al) 13 June 2002 (13.06.2002) entire document	10	Y	US 5,100,626 A (LEVIN) 31 March 1992 (31.03.1992) entire document	12, 13
Category*	Citation of document, with indication, where appropriate, of the relevant passages	Relevant to claim No.																								
X - Y	US 2004/0039348 A1 (KIM et al) 26 February 2004 (26.02.2004) entire document	11 ----- 1-10, 12, 13																								
Y	US 2006/0276746 A1 (BURNSIDE et al) 07 December 2006 (07.12.2006) entire document	1-5																								
Y	US 5,284,480 A (PORTER et al) 08 February 1994 (08.02.1994) entire document	1-5																								
Y	WO 01/97740 A2 (MAES) 27 December 2001 (27.12.2001) entire document	6-10																								
Y	US 5,370,624 A (EDWARDS et al) 06 December 1994 (06.12.1994) entire document	8-10																								
Y	US 2002/0072789 A1 (HACKETT et al) 13 June 2002 (13.06.2002) entire document	10																								
Y	US 5,100,626 A (LEVIN) 31 March 1992 (31.03.1992) entire document	12, 13																								
<p><input type="checkbox"/> Further documents are listed in the continuation of Box C. <input type="checkbox"/></p>																										
<p>* Special categories of cited documents:</p> <table border="0"> <tr> <td>“A” document defining the general state of the art which is not considered to be of particular relevance</td> <td>“T” later document published after the international filing date or priority date and not in conflict with the application but cited to understand the principle or theory underlying the invention</td> </tr> <tr> <td>“E” earlier application or patent but published on or after the international filing date</td> <td>“X” document of particular relevance; the claimed invention cannot be considered novel or cannot be considered to involve an inventive step when the document is taken alone</td> </tr> <tr> <td>“L” document which may throw doubts on priority claim(s) or which is cited to establish the publication date of another citation or other special reason (as specified)</td> <td>“Y” document of particular relevance; the claimed invention cannot be considered to involve an inventive step when the document is combined with one or more other such documents, such combination being obvious to a person skilled in the art</td> </tr> <tr> <td>“O” document referring to an oral disclosure, use, exhibition or other means</td> <td>“&amp;” document member of the same patent family</td> </tr> <tr> <td>“P” document published prior to the international filing date but later than the priority date claimed</td> <td></td> </tr> </table>			“A” document defining the general state of the art which is not considered to be of particular relevance	“T” later document published after the international filing date or priority date and not in conflict with the application but cited to understand the principle or theory underlying the invention	“E” earlier application or patent but published on or after the international filing date	“X” document of particular relevance; the claimed invention cannot be considered novel or cannot be considered to involve an inventive step when the document is taken alone	“L” document which may throw doubts on priority claim(s) or which is cited to establish the publication date of another citation or other special reason (as specified)	“Y” document of particular relevance; the claimed invention cannot be considered to involve an inventive step when the document is combined with one or more other such documents, such combination being obvious to a person skilled in the art	“O” document referring to an oral disclosure, use, exhibition or other means	“&” document member of the same patent family	“P” document published prior to the international filing date but later than the priority date claimed															
“A” document defining the general state of the art which is not considered to be of particular relevance	“T” later document published after the international filing date or priority date and not in conflict with the application but cited to understand the principle or theory underlying the invention																									
“E” earlier application or patent but published on or after the international filing date	“X” document of particular relevance; the claimed invention cannot be considered novel or cannot be considered to involve an inventive step when the document is taken alone																									
“L” document which may throw doubts on priority claim(s) or which is cited to establish the publication date of another citation or other special reason (as specified)	“Y” document of particular relevance; the claimed invention cannot be considered to involve an inventive step when the document is combined with one or more other such documents, such combination being obvious to a person skilled in the art																									
“O” document referring to an oral disclosure, use, exhibition or other means	“&” document member of the same patent family																									
“P” document published prior to the international filing date but later than the priority date claimed																										
<p>Date of the actual completion of the international search 04 January 2010</p>		<p>Date of mailing of the international search report <b>20 JAN 2010</b></p>																								
<p>Name and mailing address of the ISA/US                  Mail Stop PCT, Attn: ISA/US, Commissioner for Patents                  P.O. Box 1450, Alexandria, Virginia 22313-1450                  Facsimile No. 571-273-3201</p>		<p>Authorized officer:                  Blaine R. Copenheaver                  PCT Helpdesk: 571-272-4300                  PCT OSP: 571-272-7774</p>																								