

(19) World Intellectual Property Organization
International Bureau



(43) International Publication Date
24 August 2006 (24.08.2006)

PCT

(10) International Publication Number
WO 2006/087032 A1

(51) International Patent Classification:
A61M 16/04 (2006.01)

(21) International Application Number:
PCT/EP2005/050660

(22) International Filing Date:
15 February 2005 (15.02.2005)

(25) Filing Language: English

(26) Publication Language: English

(71) Applicant (for all designated States except US):
PATENTS EXPLOITATION COMPANY BV [NL/NL];
Herengracht 469, NL-1017 BS Amsterdam (NL).

(72) Inventor; and

(75) Inventor/Applicant (for US only): **ALBERTOLLI, Luigi** [CH/IT]; Via Comunale, Taverne, I-66019 Torricella Peligna (IT).

(74) Agents: **JORIO, Paolo** et al.; Studio Torta S.r.l., Via Viotti, 9, I-10121 Torino (IT).

(81) Designated States (unless otherwise indicated, for every kind of national protection available): AE, AG, AL, AM, AT, AU, AZ, BA, BB, BG, BR, BW, BY, BZ, CA, CH, CN, CO, CR, CU, CZ, DE, DK, DM, DZ, EC, EE, EG, ES, FI, GB, GD, GE, GH, GM, HR, HU, ID, IL, IN, IS, JP, KE, KG, KP, KR, KZ, LC, LK, LR, LS, LT, LU, LV, MA, MD, MG, MK, MN, MW, MX, MZ, NA, NI, NO, NZ, OM, PG, PH, PL, PT, RO, RU, SC, SD, SE, SG, SK, SL, SM, SY, TJ, TM, TN, TR, TT, TZ, UA, UG, US, UZ, VC, VN, YU, ZA, ZM, ZW.

(84) Designated States (unless otherwise indicated, for every kind of regional protection available): ARIPO (BW, GH, GM, KE, LS, MW, MZ, NA, SD, SL, SZ, TZ, UG, ZM, ZW), Eurasian (AM, AZ, BY, KG, KZ, MD, RU, TJ, TM), European (AT, BE, BG, CH, CY, CZ, DE, DK, EE, ES, FI, FR, GB, GR, HU, IE, IS, IT, LT, LU, MC, NL, PL, PT, RO, SE, SI, SK, TR), OAPI (BF, BJ, CF, CG, CI, CM, GA, GN, GQ, GW, ML, MR, NE, SN, TD, TG).

Published:

— with international search report

For two-letter codes and other abbreviations, refer to the "Guidance Notes on Codes and Abbreviations" appearing at the beginning of each regular issue of the PCT Gazette.

(54) Title: DILATATIVE PERCUTANEOUS TRACHEOTOMY DEVICE

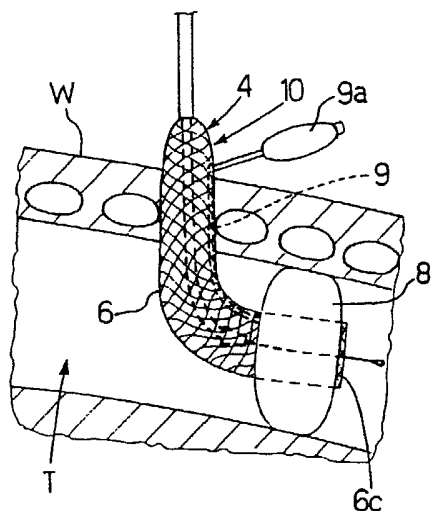

(57) Abstract: A dilatative percutaneous tracheotomy device (10). The device (10) includes a cannula (4), and elements for converting the cannula (4) from a contracted position to an expanded position. The cannula (4) is a shape-memory cannula (4), and is convertible from the contracted position to the expanded position using the intrinsic characteristics of the materials of which it is made.

WO 2006/087032 A1

5

DILATATIVE PERCUTANEOUS TRACHEOTOMY DEVICE

TECHNICAL FIELD

The present invention relates to a dilatative
10 percutaneous tracheotomy device.

BACKGROUND ART

As is known, tracheotomy, i.e. the creation of a
stoma directly connecting the dermis of the neck to the
trachea, is recommended in Intensive Care to reduce
15 damage caused by prolonged tracheal intubation in the
treatment of various pathologies, in which the patient is
unable to breathe unaided or to eliminate bronchial
secretions.

Until a few years ago, tracheotomy was a surgical
20 operation performed by an otorhinolaryngologist, either
in Intensive Care or, at times, preferably in the
operating theatre.

Surgical tracheotomy performed in Intensive Care,
however, has numerous drawbacks (infection of the stoma
25 and adjacent tissues, failure of tracheal sutures,
abnormal dilatation of tracheal tissue preventing
convenient ventilation of the patient, etc.) and was
therefore performed reluctantly.

To eliminate the aforementioned drawbacks, European Patent EP-B1-0 784 989 (Cook Inc.) proposes forming a tracheal stoma using a single increasing-gauge dilator guided by a metal wire positioned beforehand inside the
5 trachea.

More specifically, the technique proposed in EP-B1-0 784 989 (Cook Inc.) comprises first pricking the trachea with a needle; making a small cut at the hole; threading a metal guide wire inside the needle; and withdrawing the
10 needle, leaving only the metal guide wire in place.

A dilator is immediately fitted over the guide wire, and has a small-diameter first tubular portion with a first balloon, into which a pressurized fluid is fed to dilate the hole made by the needle.

15 The first balloon is then deflated, and a second tubular portion of the dilator, larger in diameter than the first portion, is then inserted inside the hole formed in the wall of the trachea.

The second portion is practically equal in diameter
20 to the hole through the epidermis and trachea.

The first portion is then withdrawn from the second portion, and a second balloon, at the end of the second portion inside the trachea, is inflated to lock the second portion of the device inside the trachea.

25 Though a considerable step forward with respect to prior techniques, the technique in EP-B1-0 784 989 (Cook Inc.) nevertheless has various limitations. That is, being rigid, the dilator used exposes the patient to the

risk of rupturing the tracheal rings, which may result in serious bleeding and/or the creation of a foreign body which, if not detected and removed, may result in a pulmonary abscess. Another drawback lies in positioning
5 of the dilator requiring force perpendicular to the trachea, thus possibly damaging the rear wall of the trachea and resulting in pneumothorax and subcutaneous emphysema.

The need for an improved dilatative tracheotomy
10 technique is therefore obvious.

DISCLOSURE OF INVENTION

It is an object of the present invention to provide a tracheotomy device designed to eliminate the
aforementioned drawbacks, and which provides for greatly
15 improving current dilatative tracheotomy techniques.

According to the present invention, there is provided a tracheotomy device as claimed in Claim 1.

The tracheotomy device according to the present invention comprises a straightforward cannula, which is
20 induced to pass from a contracted state to an expanded state to dilate a hole formed in a patient's trachea.

BRIEF DESCRIPTION OF THE DRAWINGS

A non-limiting embodiment of the present invention will be described by way of example with reference to the
25 accompanying drawings, in which:

Figure 1 shows a first step, in which a syringe needle is inserted into the patient's trachea;

Figure 2 shows a second step, in which the body of

the syringe is detached from the needle;

Figure 3 shows a third step, in which a guide wire is threaded through the needle;

Figure 4 shows a fourth step, in which the needle is being removed from the guide wire, which remains partly inside the trachea;

Figure 5 shows a fifth step, in which the needle has been completely removed, leaving the guide wire in position;

Figure 6A shows a sixth step, in which a hooded tracheostomic cannula is fitted over the guide wire;

Figure 6B shows an enlarged detail of the hooded tracheostomic cannula in Figure 6A;

Figure 7 shows a seventh step, in which a tubular portion of the cannula in Figures 6A, 6B is dilated;

Figure 8 shows an eighth step, in which a balloon-like retaining member at the distal end of the Figure 6A, 6B cannula is inflated;

Figure 9 shows a ninth step, in which parts of the Figure 6A, 6B cannula are withdrawn;

Figure 10 shows a tenth step, in which a fastening member is fitted to the tubular portion in Figure 7 projecting from the patient's dermis;

Figure 11 shows an eleventh step, in which a tube of a respirator or bronchial secretion aspirator is connected to the fastening member in Figure 10.

BEST MODE FOR CARRYING OUT THE INVENTION

Figure 1 shows the first step in the use of a device

10 (see below) in accordance with the invention. At this step, after administering a local anaesthetic, a surgical operator (not shown) inserts a needle 1 through the wall W of the trachea T of a patient (shown only partly),
5 between two tracheal rings.

A through hole H is thus formed in tracheal wall W to connect the outside atmosphere to the inside of trachea T.

A syringe body 2 is attached in known manner to
10 needle 1, and the surgical operator ensures needle 1 is positioned correctly by withdrawing the plunger of syringe body 2 to determine withdrawal of air.

As shown in Figure 2, the operator detaches syringe body 2 from needle 1 and trachea T.

15 Needle 1 thus remains inserted through wall W of trachea T, as shown in Figure 3.

As shown in Figure 3, the operator then threads a guide wire 3 through needle 1. Wire 3 must be inserted rearwards towards the end of the bronchial tree, making
20 sure guide wire 3 slides freely, thus showing it is positioned correctly.

An incision (not shown) of about four millimetres is then made at through hole H.

So far, the technique in no way differs from
25 conventional techniques, all of which are based on the Seldinger technique used for many years in various fields of medicine.

At this point, however, in innovative manner and

using guide wire 3 as a guide member, a hooded tracheostomic cannula 4, which may be formed using typical vascular stent technology, is inserted into trachea T (see Figures 6A, 6B onwards).

5 In addition to a stent, the structure of cannula 4 may also be defined by a metal coil (not shown).

As shown in detail in the Figure 6B enlargement, cannula 4 comprises a tubular inner member 5 having a sagittal end 5a, in turn having a shoulder 5b on which
10 rests a shape-memory cylinder 6 (see below).

Tubular inner member 5 is hollow, and has a cavity 5c which slides freely on guide wire 3.

Shape-memory cylinder 6 in turn comprises an elastic metal mesh 6a immersed in a matrix 6b of easily
15 deformable plastic material. More specifically, a first end 6c of cylinder 6 rests on shoulder 5b.

Shape-memory cylinder 6 is maintained in the compressed configuration shown in Figure 6B by a sheath 7 also made of a convenient plastic material of a certain
20 elasticity.

As shown in Figure 6B, the distal end of cylinder 6 is surrounded by a balloon-like inflatable member 8.

In Figure 6B, member 8 is shown deflated, and, in use (see below), can be fed with gas (e.g. air) by means
25 of a small tube 9 incorporated in cylinder 6 (see below).

In fact, as shown in Figure 7, when the operator, after inserting cannula 4 inside trachea T, slides sheath 7 in the direction of arrow F, shape-memory cylinder 6,

no longer compressed by sheath 7, expands by virtue of the elasticity of both metal mesh 6a and matrix 6b made of plastic material of a certain elasticity.

The stent or metal coil tracheostomic cannula (cylinder 6) may also be fitted inside with a liquid- or air-inflatable balloon, which may or may not be used to improve tracheal tissue dilatation. The balloon may be inflated after removal of sheath 7, is the same length as cylinder 6, promotes expansion of the tracheostomic cannula, and is deflated and removed after use.

To perform this step correctly, the operator obviously holds member 5 in place from outside trachea T, and slides sheath 7 in the direction of arrow F. In other words, the operator must create a relative movement between sheath 7 and member 5.

Sheath 7 may be removed by sliding it upwards as shown in Figure 7, or may be a "peel-away" type, i.e. with two weak opposite longitudinal slits, by which the end of the sheath is first torn, and, when pull is exerted, the sheath splits into two, allowing cylinder 6 to expand.

Expansion of cylinder 6 (Figure 7) widens hole H and the related surgical incision, if any.

At this point, using a bellows 9a (Figures 7-9) connected by the operator in the meantime to tube 9, inflatable member 8 (Figures 8-11) is inflated to secure cylinder 6 inside trachea T.

Figure 10 shows the situation in which sheath 7 has

been removed completely in the direction of arrow F to free cylinder 6, which at this point functions as a tube to which a fitting 9b is attached to fix to wall W a second end 6d of cylinder 6, which projects outwards of
5 trachea T.

As shown in Figure 11, at this point, the operator may attach a fitting 9c of a respirator or bronchial secretion aspirator (shown only partly) to end 6d of cylinder 6.

10 Cannula 4, inflatable member 8, and tube 9 form part of device 10 according to the present invention.

Clearly, changes may be made without, however, departing from the scope of the present invention.

One variation (not shown) of the device according to
15 the present invention employs a preformed or non-preformed high-pressure cannula system.

In this case, a cylinder of non-extensible, collapsible material is used. The cylinder comprises two walls about 1.2 mm apart, a gap-filling system, and a
20 distal retaining hood, and is inserted, in the fully retracted position, inside a sheath which may be of the peel-away type already described.

The procedure is identical to the one already described up to Figure 6A.

25 At this point, sheath 7 is withdrawn, and, by means of a colour-coded fill channel, the gap in the cylinder is filled under pressure. Being preformed and made of expansible material, the cylinder dilates the patient's

tissue symmetrically and assumes an expanded configuration typical of a tracheostomic cannula. Once the tracheotomy is formed, air is fed into the inflatable retaining member (hood) of the cannula by means of a
5 second inflation line.

The cylinder may be expanded using pressurized fluid, setting gel, or bicomponent materials which set when mixed together. The latter two substances produce a long-lasting tracheostomic cannula, with obvious benefits
10 to the patient.

The advantages of the present invention are as follows:

- insertion of the device according to the invention is fast and easy, can be performed by one operator, and
15 can be mastered more or less immediately, especially by anyone already experienced in dilatative tracheotomy;

- unlike prior-art techniques, at no time is a gaping tracheal stoma present between dilatation and insertion of the cannula; this is extremely important, in
20 that, while the stoma is wide open, oxygenation of the patient cannot be ensured, and numerous cases of desaturation are recorded, especially when insertion of the cannula proves difficult and further dilatation is required; moreover, a gaping stoma exposes the operator
25 and bystanders to splattering by blood and/or bronchial secretion;

- the trachea and peritracheal tissue being gradually dilated radially, the tissue is in no way

lacerated, but simply compressed and shifted aside by the cannula passing from the contracted to the memory, i.e. expanded, position; by virtue of this mechanism, the technique according to the present invention minimizes
5 the risk of bleeding, and eliminates any risk of damage to the tracheal rings;

- the device according to the invention eliminates any risk of damage to the rear wall of the trachea, thus preventing subcutaneous emphysema or pneumothorax;

10 - extubation and reintubation of the patient are not necessary, both these operations being performed with the cannula already in position;

- airways are fully controlled continuously; and

15 - the procedure is so fast - from three to five minutes - as to be also usable in emergency ventilation and tracheotomy situations, in which a fast, safe, simple method may be decisive in terms of prognosis.

CLAIMS

- 1) A dilatative percutaneous tracheotomy device (10); the device (10) being characterized by comprising:
5 a cannula (4); and
means for converting said cannula (4) from a contracted position to an expanded position.
- 2) A device (10) as claimed in Claim 1; the device (10) being characterized in that:
10 said cannula (4) is a shape-memory cannula (4); and
said means convert said cannula (4) from a contracted position to an expanded position using the intrinsic characteristics of the materials of which said shape-memory cannula (4) is made.
- 15 3) A device (10) as claimed in Claim 1; the device (10) being characterized in that said cannula (4) comprises a cylinder having a gap that can be filled with a product by which to expand said cylinder.
- 4) A device (10) as claimed in Claim 2,
20 characterized in that said cannula (4) comprises a shape-memory cylinder (6) covered with a withdrawable sheath (7); withdrawal of said sheath (7) producing the desired expansion of said shape-memory cylinder (6).
- 5) A device (10) as claimed in Claim 2,
25 characterized in that said cannula (4) comprises a shape-memory cylinder (6) covered with a sheath (7); said sheath (7) being a "peel-away" type; and removal of said sheath (7) producing the desired expansion of said shape-

memory cylinder (6).

6) A device (10) as claimed in Claim 4 or 5, characterized in that said shape-memory cylinder (6) comprises an elastic metal mesh or an elastic metal coil
5 (6a) immersed in a matrix (6b) of elastic plastic material.

7) A device (10) as claimed in any one of the foregoing Claims, characterized in that said cannula (4) has an inflatable member (8) at its distal end.

10 8) A device (10) as claimed in Claim 2 or 3, characterized in that said cannula (4) comprises means (9b) by which to attach said cannula (4) to a fitting (9c) forming part of a respirator or bronchial secretion aspirator.

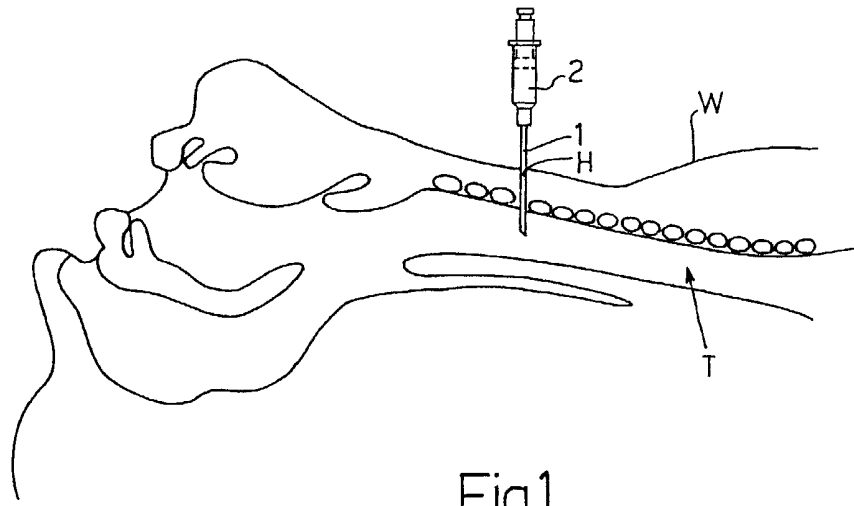

Fig.1

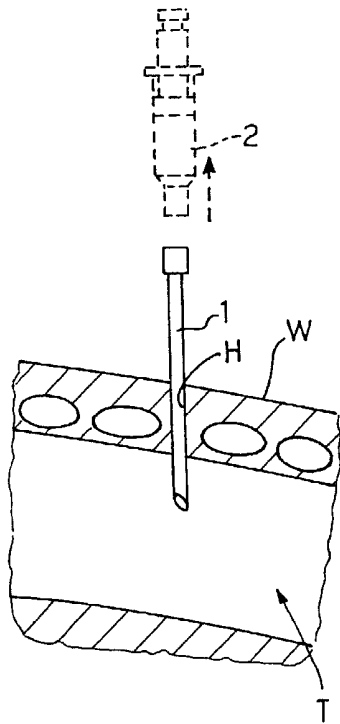

Fig.2

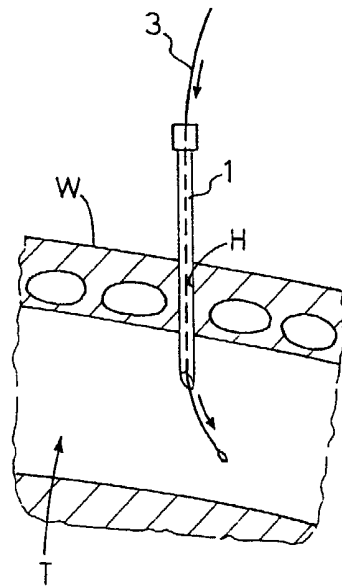

Fig.3

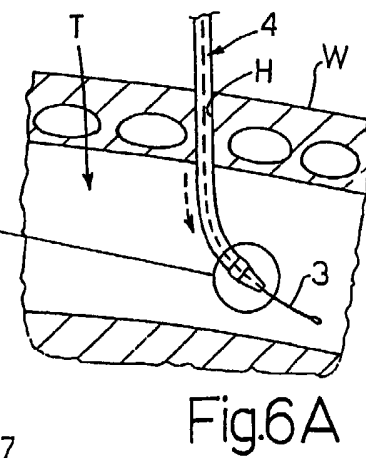
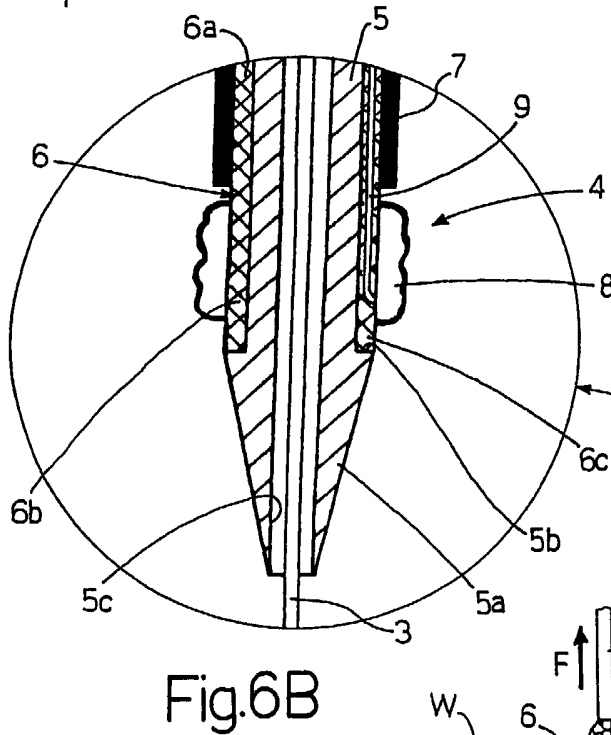
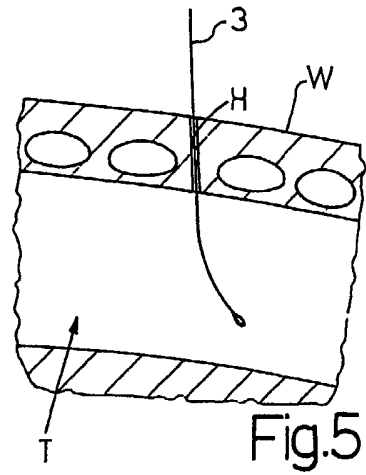
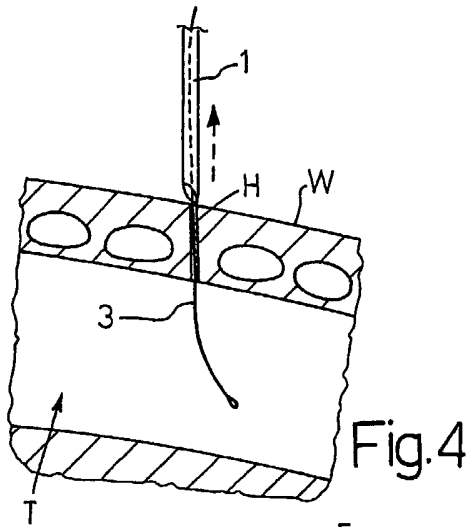

Fig.6B

Fig.6A

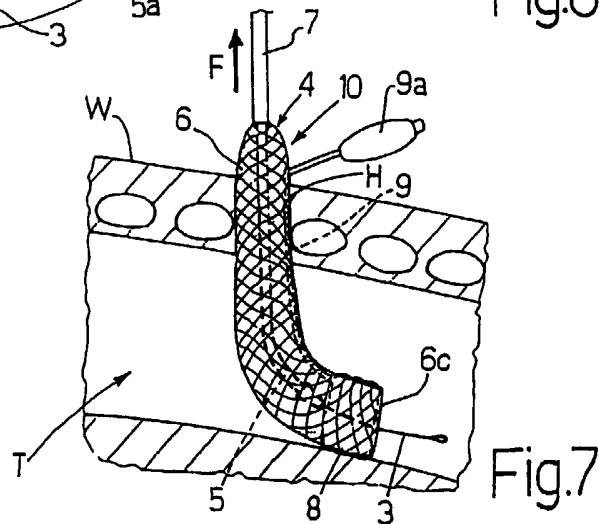
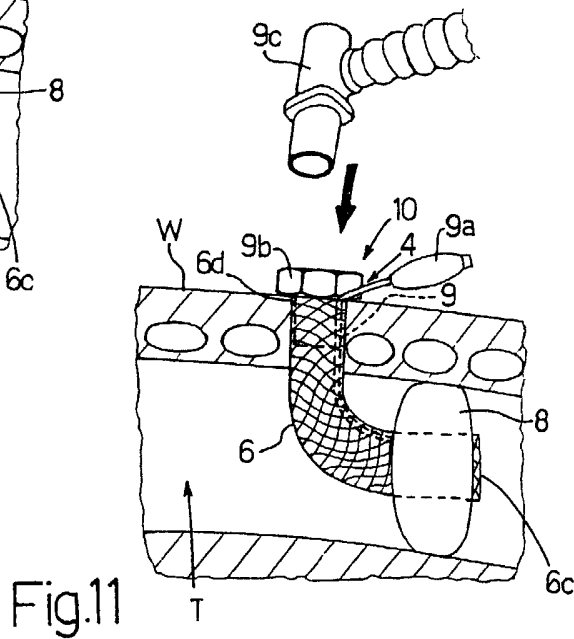
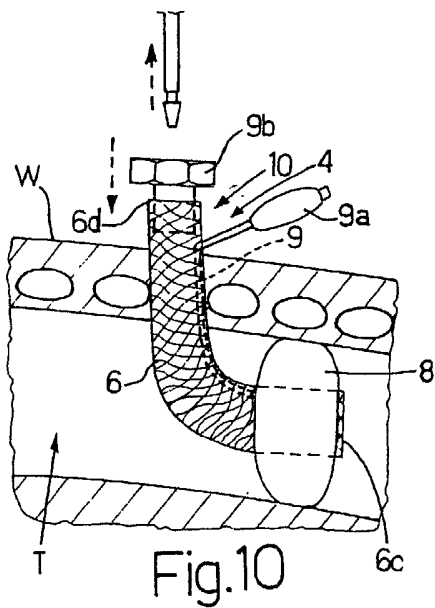
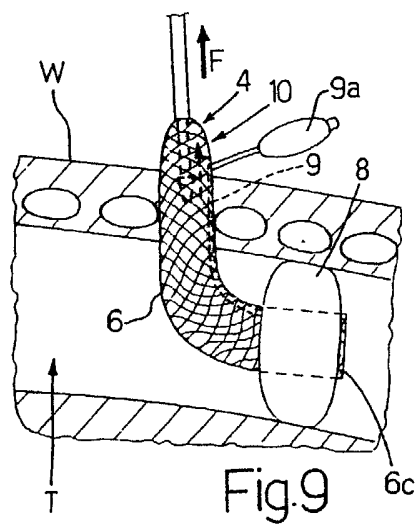
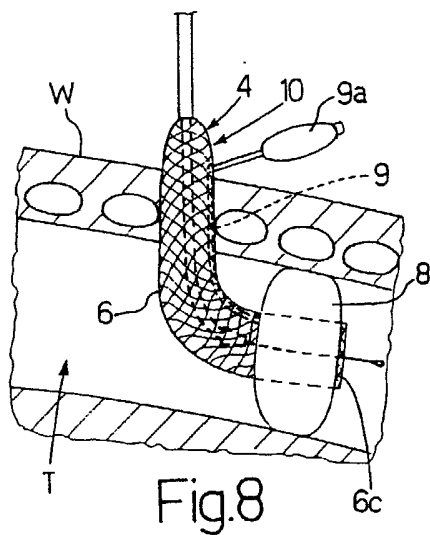

Fig.7



INTERNATIONAL SEARCH REPORT

International Application No
PCT/EP2005/050660

| | | | | |
|---|--|---|---|--|
| A. CLASSIFICATION OF SUBJECT MATTER IPC 7 A61M16/04 | | | | |
| According to International Patent Classification (IPC) or to both national classification and IPC | | | | |
| B. FIELDS SEARCHED | | | | |
| Minimum documentation searched (classification system followed by classification symbols) IPC 7 A61M | | | | |
| Documentation searched other than minimum documentation to the extent that such documents are included in the fields searched | | | | |
| Electronic data base consulted during the international search (name of data base and, where practical, search terms used) EPO-Internal | | | | |
| C. DOCUMENTS CONSIDERED TO BE RELEVANT | | | | |
| Category * | Citation of document, with indication, where appropriate, of the relevant passages | Relevant to claim No | | |
| X A X A X X | US 6 840 242 B1 (MCCOY STEPHEN CRAIG) 11 January 2005 (2005-01-11) column 3, line 47 - column 7, line 14; figures ----- EP 1 092 448 A (TOYE, FREDERIC J) 18 April 2001 (2001-04-18) paragraphs '0029! - '0037!; figures ----- EP 1 044 701 A (SMITHS INDUSTRIES PUBLIC LIMITED COMPANY; SMITHS GROUP PLC) 18 October 2000 (2000-10-18) paragraphs '0009! - '0013! ----- EP 0 784 989 A (COOK INCORPORATED) 23 July 1997 (1997-07-23) cited in the application abstract; figures ----- | 1,3,7,8 2 1,3,7 2 1,3,7 1,3,7 | | |
| <input type="checkbox"/> Further documents are listed in the continuation of box C | | | | |
| <input checked="" type="checkbox"/> Patent family members are listed in annex | | | | |
| * Special categories of cited documents | | | | |
| <table style="width: 100%; border: none;"> <tr> <td style="width: 50%; border: none; vertical-align: top;"> *A* document defining the general state of the art which is not considered to be of particular relevance *E* earlier document but published on or after the international filing date *L* document which may throw doubts on priority claim(s) or which is cited to establish the publication date of another citation or other special reason (as specified) *O* document referring to an oral disclosure, use, exhibition or other means *P* document published prior to the international filing date but later than the priority date claimed </td> <td style="width: 50%; border: none; vertical-align: top;"> *T* later document published after the international filing date or priority date and not in conflict with the application but cited to understand the principle or theory underlying the invention *X* document of particular relevance, the claimed invention cannot be considered novel or cannot be considered to involve an inventive step when the document is taken alone *Y* document of particular relevance; the claimed invention cannot be considered to involve an inventive step when the document is combined with one or more other such documents, such combination being obvious to a person skilled in the art *&* document member of the same patent family </td> </tr> </table> | | | *A* document defining the general state of the art which is not considered to be of particular relevance *E* earlier document but published on or after the international filing date *L* document which may throw doubts on priority claim(s) or which is cited to establish the publication date of another citation or other special reason (as specified) *O* document referring to an oral disclosure, use, exhibition or other means *P* document published prior to the international filing date but later than the priority date claimed | *T* later document published after the international filing date or priority date and not in conflict with the application but cited to understand the principle or theory underlying the invention *X* document of particular relevance, the claimed invention cannot be considered novel or cannot be considered to involve an inventive step when the document is taken alone *Y* document of particular relevance; the claimed invention cannot be considered to involve an inventive step when the document is combined with one or more other such documents, such combination being obvious to a person skilled in the art *&* document member of the same patent family |
| *A* document defining the general state of the art which is not considered to be of particular relevance *E* earlier document but published on or after the international filing date *L* document which may throw doubts on priority claim(s) or which is cited to establish the publication date of another citation or other special reason (as specified) *O* document referring to an oral disclosure, use, exhibition or other means *P* document published prior to the international filing date but later than the priority date claimed | *T* later document published after the international filing date or priority date and not in conflict with the application but cited to understand the principle or theory underlying the invention *X* document of particular relevance, the claimed invention cannot be considered novel or cannot be considered to involve an inventive step when the document is taken alone *Y* document of particular relevance; the claimed invention cannot be considered to involve an inventive step when the document is combined with one or more other such documents, such combination being obvious to a person skilled in the art *&* document member of the same patent family | | | |
| Date of the actual completion of the international search <p style="text-align: center; font-size: 1.2em;">28 July 2005</p> | | Date of mailing of the international search report <p style="text-align: center; font-size: 1.2em;">26/08/2005</p> | | |
| Name and mailing address of the ISA European Patent Office, P.B. 5818 Patentlaan 2 NL - 2280 HV Rijswijk Tel (+31-70) 340-2040, Tx. 31 651 epo nl, Fax (+31-70) 340-3016 | | Authorized officer <p style="text-align: center; font-size: 1.2em;">Vänttinen, H</p> | | |

INTERNATIONAL SEARCH REPORT

Information on patent family members

International Application No
PCT/EP2005/050660

| Patent document cited in search report | Publication date | Patent family member(s) | Publication date |
|--|------------------|---|--|
| US 6840242 | B1 | 11-01-2005 NONE | |
| EP 1092448 | A | 18-04-2001 US 6382209 B1 EP 1092448 A2 | 07-05-2002 18-04-2001 |
| EP 1044701 | A | 18-10-2000 AT 295196 T AU 765068 B2 AU 2524400 A CA 2305055 A1 DE 60020002 D1 EP 1044701 A2 GB 2350061 A , B JP 2000308683 A NZ 503623 A US 6481436 B1 ZA 200001797 A | 15-05-2005 11-09-2003 19-10-2000 12-10-2000 16-06-2005 18-10-2000 22-11-2000 07-11-2000 24-11-2000 19-11-2002 30-10-2000 |
| EP 0784989 | A | 23-07-1997 US 5653230 A AU 723741 B2 AU 1221397 A CA 2194925 A1 DE 69729339 D1 DE 69729339 T2 EP 0784989 A2 ES 2221016 T3 JP 9299377 A | 05-08-1997 07-09-2000 24-07-1997 20-07-1997 08-07-2004 23-06-2005 23-07-1997 16-12-2004 25-11-1997 |