

12

EUROPEAN PATENT APPLICATION

21 Application number: 87310079.6

51 Int. Cl.⁴: **H 01 R 23/10**

22 Date of filing: 16.11.87

30 Priority: 18.11.86 US 932921 02.09.87 US 91002

43 Date of publication of application:
25.05.88 Bulletin 88/21

84 Designated Contracting States:
AT BE CH DE FR GB IT LI LU NL SE

71 Applicant: **E.I. DU PONT DE NEMOURS AND COMPANY**
1007 Market Street
Wilmington Delaware 19898 (US)

72 Inventor: **Lemke, Timothy Allen**
827 Pine Road
Carlisle Pennsylvania 17013 (US)

74 Representative: **Barnard, Eric Edward et al**
BROOKES & MARTIN High Holborn House 52/54 High
Holborn
London WC1V 6SE (GB)

54 **Terminator for multiple electrical conductors.**

57 A terminator for a multiple conductors (16,88) includes a ground structure (22) with generally U-shaped channels (34). Each channel receives an insulated finger (54) having an electrical contact element (58). When the ground structure is connected to ground potential the contacts (58) are electrically isolated from each other.

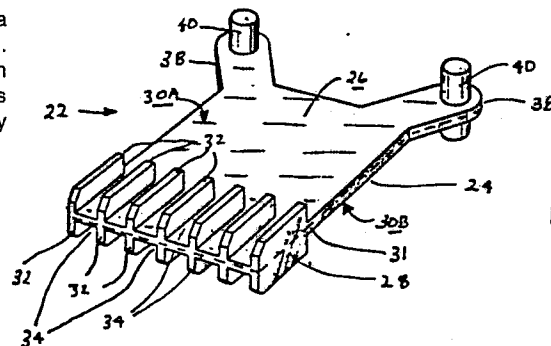

FIG. 2

DescriptionTERMINATOR FOR MULTIPLE ELECTRICAL CONDUCTORS**Background of the Invention**

The present invention relates to a terminator having electrical contacts therein each connectable to one of a multiplicity of electrical conductors, and in particular, to a terminator having a ground structure therein arranged to isolate each electrical contact.

Description of the Prior Art

As the performance of electronic devices has increased exponentially it has become recognized in the art that the transmission of electrical signals, whether within a given electronic apparatus or between coupled apparatuses, must be approached from a system viewpoint. Such a viewpoint mandates that not only must each individual component in the signal transmission system be optimized for high speed operation but also the interfaces between components in the transmission system must be able to perform interactivity without degrading the performance of an adjacent component.

One of the first components in the signal transmission system to receive attention is the transmission cable itself. The realization has been made that the cable handling the high speed signals is the electrical equivalent of a transmission line in that it extends an electrically great distance with respect to the wavelength of the transmitted signals. This is true even though in most instances the cable extends only a physically short distance between components of a given apparatus or between cooperating apparatus.

The design of electrical cable has advanced to a point wherein the cable can be precisely engineered to exhibit predetermined electrical properties. Exemplary of such cable structure is that disclosed in the copending European patent application 87306883.7. The cable disclosed in this application includes a corrugated ground structure which defines separate enclosed regions, or envelopes, which extend throughout the entire length of the cable. Each of the envelopes receives one or more ordinary jacketed conductors. When the ground structure is connected to a predetermined electrical potential the conductor in each envelope is isolated totally from those conductors disposed in adjacent envelopes. As a result such a cable exhibits electrical properties closely similar to those attainable from coaxial cable despite the fact that only ordinary jacketed conductors are utilized.

The system viewpoint has expanded to include consideration of electrical performance in the transition region intermediate the end of the cable and the cable terminator. The connector structure disclosed and claimed in the copending European patent application 87308941.1 utilizes a ground plane spaced predetermined distances from the ends of the conductors in the cable, the contacts in the connector and the interconnection therebetween for the purpose of minimizing electrical discontinuities

in the system.

Density of the terminator, that is, the number of signals that can pass through a given terminator, is also an important consideration. In conventional systems attempts have been made to extend the shielding and control the impedance of the system beyond the transmission line by simply dedicating alternating contacts in the linear array of contacts in the terminator as ground contacts. The contacts are not physically altered, but are merely designated as a ground contact and connected to a predetermined ground potential. The net result of these factors is that the density of the terminator is limited.

In view of the foregoing it is believed advantageous to further extend the system concept to the individual terminator of the transmission system and also to increase the density of the terminator. Accordingly, it is believed to be of advantage to provide a terminator for either a multiple conductor cable or a multiple tracing substrate that electrically isolates the contact elements in the terminator to prevent or minimize cross talk between adjacent conductors and to prevent or minimize degradation of signal transmission. In addition, it is believed advantageous to provide the isolating structure in the terminator in such a fashion that the contacts need not themselves be included as part of the isolating structure whereby the signal density of the terminator may be increased.

Summary of the Invention

The present invention relates to a terminator for a multiple conductor electrical transmission system in which a ground structure is provided which electrically isolates each of the adjacent electrical contact elements disposed in the terminator. The transmission system may be implemented as a multiconductor cable or as a multiple tracing substrate, with the terminator being adapted to interconnect in substrate-to-substrate, cable-to-cable, or cable-to-substrate form.

In a first aspect the terminator includes metallic ground structure formed of a baseplate with a plurality of walls that extend upwardly from a surface of the baseplate. In the preferred case a series of walls also extends from the opposite surface of the baseplate. The walls cooperate to define a plurality of channels that extend in side-by-side relationship across the surface of the baseplate. An insulated support structure having a body portion with an array of extending fingers is mounted on the baseplate with the fingers extending into the channels on the baseplate. An electrical contact element is mounted on each of the fingers such that the walls extend above the baseplate for a greater distance than does the electrical contact. The fingers may each be provided with a recess in which a spring electrical contact is disposed. As a result, with the ground structure connected to a predetermined potential, each of the contacts is electrically isolated from the adjacent contact, thus preventing

or minimizing cross talk therebetween.

The terminator can be implemented in the form suitable for the edge terminator of a substrate such as a circuit board, or as a plug terminator for a multiple conductor cable. In the former instance the ground structure is provided with a suitable mounting arrangement whereby the ground structure may be mounted in edgewise relationship to the substrate. In the latter instance a suitable housing is provided to define the plug portion. In one instance the portion of the ground structure having the walls thereon and the extending fingers of the insulated support structure project forwardly from the housing. In another instance the housing is coextensive with the forward face of the insulated support structure and the ground structure. The insulating support structure may be provided with trenches therein which receive the individual conductors of the cable. Alternatively the wires of the conductors may be facially welded to the contacts.

In another aspect the invention relates to a housing for a terminator. The housing has an array of lands separated in one instance by alternate grooves or, in another instance, by alternate slots. The lands carry electrical contact elements thereon. In the embodiment in which the grooves are used a separate array of contact elements is provided in the grooves. In the embodiment with the slotted housing, the exterior of the housing is provided with a ground plate that communicates with at least one of the slots. In each instance the housing is connectable to the plug such that the signal carrying contacts disposed within the channels on the ground structure are electrically interengaged with the contact elements on the lands. The walls of the ground structure are disposed in electrical contact with either the contacts provided in the grooves or the plate overlying the slots. When conjoined the plug and housing provides electrical shielding for the contact elements in the terminator (in either the cable plug form or the edge card form), thus preventing or minimizing cross talk and degradation and maintaining electrical signal integrity.

Brief Description Of The Drawings

The invention will be more fully understood from the following detailed description thereof, taken in connection with the accompanying drawings which form a part of this application and in which:

Figure 1 is a perspective view of an assembled terminator in accordance with the present invention implemented as a plug terminator for a multiconductor cable;

Figure 2 is an exploded perspective view of the plug terminator shown in Figure 1;

Figure 3 is a side elevational view taken along section lines 3-3 of the plug terminator of Figures 1 and 2;

Figure 4 is a front perspective view of a terminator in accordance with the present invention implemented in the form of an edge card terminator;

Figure 5 is a back view of the edge card terminator of Figure 4;

Figure 6 is a perspective view of a housing

assembly adapted to accept a terminator in accordance with the present invention whether the terminator is implemented in either the cable plug form or the edge card form;

Figure 7 is a side view entirely in section of the housing of Figure 6;

Figure 8 is a front elevation view of the terminator of Figure 6;

Figure 9 is a perspective view similar to Figure 6 showing an alternate embodiment of a housing adapted to receive the terminator of the present invention whether the terminator is implemented in either the cable plug form or the edge card form; and,

Figure 10 is an exploded perspective view of an alternate embodiment of a plug terminator for a multiconductor cable generally similar to Figure 2; and,

Figure 11 is a side elevational view in vertical section, generally similar to Figure 3, taken along section lines 11-11 in Figure 10 to include the central axis of a finger of the insulated support structure of the plug terminator.

Detailed Description of the Invention

Throughout the following detailed description similar reference numerals refer to similar elements in all figures of the drawings.

With reference to Figures 1 to 3 shown is a terminator generally indicated by reference character 10 in accordance with the present invention implemented in the form of a plug terminator for a multiple conductor cable 12. Although the cable 12 is shown in the Figures as being a round transmission cable it lies within the contemplation of the present invention that the plug terminator (10 or 10', Figures 10 and 11) as disclosed herein may be used with equal efficacy in conjunction with a flat cable (either ribbon cable or discrete wire cable).

The cable 12 includes an outer jacket 14 (Figure 3) of an insulating material surrounding a plurality of individual jacketed conductors 16. Each conductor 16 itself includes an insulating jacket 16J surrounding a wire conductor 16W. A conducting sheath 18 disposed under the outer jacket 14 of the cable 12 serves as a portion of the grounding and shielding structure of the cable 12. The sheath 18 is terminated by a metallic ferrule 20, such as that disclosed in US-A-4,416,501.

As is best seen in Figures 2 and 3 the heart of the plug terminator 10 is a metallic ground structure 22. The ground structure 22 includes a baseplate portion 24 having a main planar surface with an integral portion 28 projecting forwardly therefrom. Although the ground structure 22 is shown as being provided with an upper and a lower working surface 30A and 30B respectively thereon, it should be understood that a ground structure 22 having only one working surface 30 may be used and remain within the contemplation of the present invention. More specifically, the terminator can be implemented with a ground structure that includes only the structure on the upper working surface 30A of the ground structure 2 (that is, the structure above the dividing plane 31 extending through the base-

plate portion 24 of the ground structure 22). In such an instance the opposite surface of the ground structure 22 would preferably be planar. Moreover, the remaining elements of the terminator as hereafter described would be appropriately modified to accept a ground structure 22 of this form.

A plurality of walls 32 extends from the forward projecting portion of the respective upper and lower working surface 30A, 30B, respectively, of the baseplate 24. The walls 32 are arranged in side-by-side relationship to define a plurality of channels 34 across the surfaces of the projecting portion 28 of the baseplate 24. In the preferred embodiment the axes of the adjacent channels 34 are parallel to each other, although it is understood that such a relationship is not mandated. It should also be understood that although each working surface 30A, 30B of the baseplate 24 is shown as having the same number of channels 34, such a situation is also not necessarily required.

The planar portion 26 of the baseplate 24 behind the projecting portion 28 has flanges 38 which flare farther rearwardly and slightly outwardly from the baseplate 24. The flanges 38 carry posts 40. In some instances it may be desired that the posts 40 be electrically conductive and in electrical contact with the conductive material of the baseplate 14. It should be appreciated that a ground structure of more than two working surfaces may be defined by disposing additional baseplates 24 (whether each baseplate implemented with one or two working surfaces) in any convenient stacked relation.

In the Figures the ground structure 22 is shown as being fabricated as an integral metallic member, although it should be understood that any suitable construction for the ground structure 22 may be used. For example, the ground structure 22 can be formed from plastic with its entire upper and lower working surfaces 30A, 30B (including the walls 32 on the projecting portions 28) lined with a suitable conductive material. Alternately, the baseplate 24 may be formed or stamped from a sheet of conductive material with slots provided near the forward end thereof. The end walls 32 may be formed from similar slotted stampings. The baseplate 24 and the walls 32 are joined via the slots to define the ground structure 22 as shown in the Figures.

In one embodiment of the cable plug form of the invention the plug terminator 10 further comprises a contact support member 44 having a main body portion 46 with an array of trenches 48 formed therein. The contact support member 44 is formed of an insulating material. A partition 50 having an indentation 50G is provided near the forward end of the body portion 46 of the contact support member 44. An array of apertures 52 (visible on the lower member 44 in Figure 2) is provided through the body 46 of the support member 44 in the region behind the partition 50, with one of the apertures 52 being aligned with the mouth of each of the grooves 48 for a purpose to be described. An array of fingers 54 extends forwardly from the body 46. The fingers 54 correspond in number to the number of channels 34 provided on the ground structure 22. In the assembled condition the fingers 54 extend into the

channels 34 so that the forward ends of the fingers 54 are coterminous with the forward edge of the ground structure 22.

An array of electrical contact elements 58 of any suitable configuration are embedded in the insulating material of the fingers 54. The contact elements 58 are arranged such that the planar blade of each contact element 58 is exposed on the surface of the finger 54 in which it is disposed. The contact element 58 extends rearwardly from the fingers 54 through the material of the partition 50. The contact element 58 ends in an overlying relationship with the apertures 52 in the body 46 just forwardly of the mouths of the trenches 48 therein. As seen in the Figures the top surfaces of the walls 32 of the ground structure 22 extend above the contact elements 58 when the same are received in the channels 34.

The plug 14 includes a protective casing generally indicated by reference character 64. The casing 64 is defined by complementary shell members 66A, 66B. Each shell member 66A, 66B has a forward cutout 68 having a tongue 68T therein. The configuration of the cutout 68 corresponds to the configuration of the body portion 46 of the contact support member in the vicinity of the partition 50. The rear wall of each of the shell members 66A, 66B has cooperating grooved openings 70 therein. The openings 70 are shaped to generally conform to the exterior configuration of and are sized to closely accept the transmission cable 12 in either round or flat form.

Adjacent to the rear wall of the shells 66A, 66B is a pair of abutments 72 with recesses 74. The recesses 74 are configured to accept snugly the posts 40 on the ground structure 22 in a press fit relationship. In the preferred case the shells 66A, 66B are each fabricated of a conductive material. It should be understood that the shells may be fabricated from a plastic material in which case a conductive surface 76 is formed by a suitable conductor layer disposed on the inner surface of each of the shells 66A, 66B (as shown in Figure 3 for economy of illustration). The sidewalls of the shells 66A, 66B each carry notches 78 sized to accept locking tabs 80 which serve to hold the casing 64 together.

In the assembled condition shown in Figures 1 through 3 the complementary shells 66A and 66B close on each other and are locked together by the tabs 80 and the press fit engagement of the posts 40 in the recesses 74 in the abutments 72. When so assembled the tongue 68T near the cutout 68 adjacent the front of the casing 64 engages in the groove 50G. The multiple conductor cable 12 extends through the registered openings 70 in the rear of the shells 66A, 66B and into the volume defined in the rear of the casing 64. The external jacket 14 of the cable 12 is stripped a predetermined distance from its end to expose the individual jacketed conductors 16 therein. An insulation displacement contact 82 severs the exterior jacket 14 of the cable 12 and electrically interconnects with the ferrule 20 of the cable 12. The insulation displacement contact 82 is captured in the grooved openings 70 adjacent the rear aperture of the shell to thereby electrically interconnect the conductive

5

10

15

20

25

30

35

40

45

50

55

60

65

surface 76 on the interior of the casing 64 to a predetermined electrical potential.

Prior to the closing of the casing by the interengagement of the shells 66A, 66B, the individual conductors 16 of the cable 12 are themselves stripped of their jackets 16J and the conductive wires 16W thereof laid in one of the trenches 48 extending in the body portion 46 of the contact support structure 44. The end of each of the wires 16W overlays the end of one of the contact elements 58. The wires 16W and the contacts 58 may be suitably attached, as by welding, solder or insulation displacement contacts to interconnect the wires 16W to the contacts 58 and remain within the contemplation of the present invention.

Figures 10 and 11 illustrate an alternative embodiment of the cable plug terminator form 10' of the invention generally similar to the embodiment of the invention shown in Figures 1 to 3. In the alternate embodiment of the invention shown in Figures 10 and 11 the contact support member 44 is provided with a main body portion 46, formed of an insulating material, from which a plurality of fingers 54 extend. The fingers 54 each include a recess 55 having a lip 55L (Figure 11) provided therein. Each finger 54 is, therefore, a substantially hollow member in which a spring electrical contact element 58 is received. The tail portion of the contact 58 is provided with a slot 58S that imparts to the tail portion of the contact 58 a configuration generally similar to that of an insulation displacement contact. The head or forward end of the contact 58 is captured by the lip 55L while the tail end of the contact 58 projects rearwardly from the main body portion 46 of the member 44. The generally linear portion 58L of the contact 58 between the curved electrical engaging region 58C and the slotted tail 58S is captured at each lateral horizontal edge of the contact 58 in a groove 59 formed in each of the sidewalls of the main portion of the support member 44. In Figure 11 a portion of the contact 58 is cut away to clearly illustrate the groove 59.

The member 44 is mounted to the ground structure 22 in a manner generally similar to the arrangement formed and shown in connection with Figures 2 and 3. The fingers 54 of the member 44 are each received in one of the channels 34 defined by the walls 32 of the ground structure 22. The member 44 is positioned on the structure 22 by the engagement of the main portion 46 of the member 44 with the inner ends of the walls 34 of the structure, as is illustrated in the Figure. The member 44 is held in the position shown in drawing Figure 11 by an abutment 26A formed on the planar portion 26 of the baseplate 24 of the structure 22. Of course, any suitable expedient may be used to position a member 44 on one (or both) surface(s) of the structure 22. The welding apertures 52 (perhaps best seen in Figure 2) provided in the planar portion 26 of the structure 22 are eliminated inasmuch as the welded attachment of the conductor wires 16W to the tail portion of the contact 58 may be effected by a facial welding process. To this end the wires 16W of the conductors 16 are bent, as at 16B (Figure 11), to cause the axis of the portion of the wire 16W

immediately rearwardly to the facial end of the wire 16W to extend linearly through the tail end portion of the contact 58.

The protective casing 64 of the connector 10' is also slightly modified from that shown in Figures 2 and 3 in that the shell portions 66A, 66B extend forwardly and turn downwardly and upwardly, respectively, to define the tongue portion 68T such that the forward edge of the casing is coextensive with the forward face 44F of the contact support member 44. The shell members 66A and 66B are held together in the same manner as that described for the arrangement of the connector shown in Figures 2 and 3. That is, the posts 40 on the ground structure 22 are press-fit into recesses 74 in the abutments 72 in the shells 66A, 66B. The sidewalls of the shells 66A, 66B are notched, as at 78, to accept locking tabs 80. As is the case in the embodiment of the invention shown in Figures 2 and 3 the casing 64 shown in Figures 10 and 11 may be fabricated entirely of a conductive material. However, as is also earlier noted, the shells 66A, 66B can be fabricated of a nonconductive material, e.g., plastic, in which event conductive layers 76 should be provided on both the interior and exterior surfaces thereof. The layers 76 are illustrated in the Figures for economy of illustration.

In all other respects the embodiment of the invention shown in Figures 10 and 11 is identical to that disclosed in connection with Figures 2 and 3. Accordingly the remaining reference characters used in Figures 10 and 11 correspond to those used in Figures 2 and 3 to identify corresponding parts. It is noted that throughout this application no significance should be attached to differences in the number of walls 32, channels 34, fingers 54, etc., used in depicting the various embodiments of the various forms of the invention.

As is seen in Figure 11 the plug 10' is received within a mating header 81. The header 81 includes an insulating housing 82 having an array of pins 83 extending therefrom. Each pin 83 is respectively received within one of the recesses 55 in the fingers 54. Each pin 83 is in electrical engagement with the electrical engaging region 58C of the contact 58. The housing 82 also contains spring contacts 84 which engage the metallic shells 66A, 66B (or the layer 76 disposed thereon in the event the shells 66A, 66B are formed of insulating material) thereby to establish a grounded interconnection with the shells 66A, 66B.

As may be seen by reference to Figures 4 and 5, a terminator 10'' in accordance with the present invention may be used in the environment of an edge card terminator for substrates such as a printed circuit board 86 having multiple conductive tracings 88 thereon. In the instance shown in Figures 4 and 5 a ground structure 22 similar to that described in connection with Figure 1 through 3 or in connection with Figures 10 and 11 is disposed both above and below the board 86. To facilitate this mounting arrangement the ground structures 22 are supported at their ends by a bracket 90. Each of the structures 22 receives a contact support member 44' generally similar to that discussed in connection

with Figures 1 through 3 or in connection with Figures 10 and 11 with the exception that the body portion 46' thereof is truncated. As seen in Figure 5, the contact elements 58 emanating from the support member 46' are directed joined to the conductive tracings 88 on the surfaces of the board 86. It should be appreciated that the terminator 10'' may be used to service only one of the surfaces of the board 86.

In practice the ground structure 22 is connectable to a predetermined electrical potential (e.g., chassis or logic ground). Since the walls 32 near the forward projecting portions 28 of the baseplate 24 extend above the signal carrying contacts 58 generally U-shaped receptacles are formed in which the signal carrying contacts 58 are disposed. The ground structure 22 thus electrically shields and isolates each signal carrying contact 58 from each adjacent signal carrying contact, whether these contacts are sidewise and/or vertically adjacent.

With reference to Figures 6 and 7 shown are perspective and sectional views of a housing assembly 100 adapted to accept a terminator 10 or 10' or 10'' as described heretofore. The housing 100 includes a main body portion 102 fabricated of a suitable insulating material such as molded plastic. The body 102 has a main opening that receives the terminator 10 or 10' or 10'' therewithin. The housing is generally similar to that described in US-A-4,601,527.

However, in accordance with the present invention the upper and lower edges of the housing 102 are provided with an alternating array of lands 106A, 106B and grooves 108A, 108B, respectively. The surfaces of the lands 106A, 106B and the troughs of the grooves 108A, 108B are provided with suitable electrical contacts 110A, 110B and 112A, 112B respectively. The contacts are retained in the housing 100 in the standard manner. It should be understood that although in Figure 6 through 9 preloaded cantilevered beam contacts are illustrated the housing 100 (or 100') in accordance with the present invention can be implemented using any suitable alternate form of contact.

As may be seen in Figure 8, in accordance with the present invention the contacts 110 and 112 are supported in the body 102 of the housing 100 such that, as measured with respect to a predetermined datum, the contacts 110 disposed on the lands 106 extend for a distance from the datum different than the distance that the contacts 112 extend from the datum. With reference to the upper array of lands 106A and grooves 108A, the reference datum is selected as the plane 116 containing the upper surface of the housing 102. As so defined it may be appreciated that the contacts 110A on the lands 106A extend for a distance 118 from the datum 116 that is greater than the distance 120 that the contacts 112A in the grooves 108A extend from the datum 116. A similar situation is extant with respect to the contacts 110B and 112B respectively provided in the lands 106B and the grooves 108B on the lower array. In the latter instance the reference datum is selected to be the plane 122 containing the lower surface of the housing 102 and the distances defined between the contacts 110A is indicated by the

5
10
15
20
25
30
35
40
45
50
55
60
65

character 124 and the distance defined by the contacts 112B is indicated by the character 126.

In the context of the dual array housing as shown in the Figures 6 through 8, an equally useful datum may be defined by a bisecting plane 130 (Figure 8) extending parallel to the arrays of contacts and midway therebetween. In this event the contacts 110A, 110B on the lands 106A, 106B respectively are spaced a distance 134 from the datum 130 while the contacts 112A, 112B in the grooves 108A, 108B, respectively are spaced from the datum 130 by the distance 136.

As a result of the staggered structural relationship of the contacts in the lands with respect to those in the grooves a terminator 10 or 10' or 10'' may be received in the housing 100 such that the upper surfaces of the walls 32 on the ground structure 22 are brought into electrically conductive engagement with the contacts in the grooves 108, while the contacts 58 supported in the contact support 44 are brought into electrically conductive engagement with the contacts 110 on the lands 106. The location of the signal and the ground connections on essentially two levels of the housing 100 permits the density of the connector to be increased. Since the ground connection is provided by the walls of the structure 22, the width dimension of the walls could be physically less than the width dimension of the signal carrying contact blades. This situation permits an increase in signal density while maintaining transmission line characteristics. Moreover the staggering of the signal and ground interconnection points on two levels permits further compression of the structure leading to yet greater density.

Finally, since isolation is provided by the ground structure 22 and not by individual ones of the contacts, all of the blades can be used to carry signals, thus further enhancing the density of the connector.

The structure of the housing shown in Figures 6 through 8 is modified slightly as shown in Figure 9. In this embodiment the lands 106 are separated by slots 140. Instead of contacts 112 of the spring type, contact plates 142 are provided that overlie a portion of the slots 140. The ground structure 22 is slightly modified in that the walls 32 are extended to a height sufficient to permit the upper surfaces of the walls 32 to contact against the contact plates 142. It should be understood that in this embodiment (as well as the embodiment shown in Figures 6 through 8) the plates 142 (and the ground contacts 112) are preferably connected in common.

Those skilled in the art may readily appreciate that in view of the foregoing a terminator and housing arrangement has been provided that provides efficient continuation of the shielding of the cable to the region of the terminator while at the same time permitting increased signal density to be achieved. The reader skilled in the art may also readily appreciate modifications to the structure of the terminator and/or housing as hereinabove set forth. It should be understood, however, that such modifications are to be construed as lying within the scope of the present invention as set forth in the appended claims.

Claims

1. A terminator for multiple electrical conductors (16,88) comprising:

a metallic ground structure (22) formed of a baseplate ((24) with a plurality of upstanding walls (32) thereon cooperating to define a predetermined number of channels (34) arranged in side-by-side relationship across the ground structure;

an insulated support structure (44) having a body portion (46) with a plurality of forwardly extending fingers (54) thereon, each of the fingers being received in one of the channels; and

an electrical contact element (58) disposed on each of the fingers, each of the contact elements being connectable to one of the conductors (16,88) so that, in use, the ground structure is connectable to a predetermined electrical potential whereby the electrical contact elements are electrically isolated from each other.

2. A terminator according to claim 1 wherein the tops of the walls (32) are spaced from the baseplate (24) a greater distance than are the contact elements (58) on the fingers (54).

3. A terminator according to claim 1 or 2 wherein the multiple electrical conductors comprise conductive tracings (88) disposed on the surface of a substrate and there is further provided:

means (90) disposed at each end of the ground structure for supporting the structure at the edge of the substrate.

4. A terminator according to claim 1 or 2 wherein the multiple conductors (16) are disposed in a cable (12) and wherein the insulated support structure (44) has a plurality of trenches (48) therein, each of the trenches being adapted to receive one of the conductors of the cable.

5. A terminator according to any one of claims 1 to 4 and further comprising:

a housing (100) having an array of lands (106) with alternating grooves (108) disposed between adjacent lands, a contact element (110,112) being disposed on each of the lands and in each of grooves, the contacts on the lands extending from a predetermined datum for a distance different from the distance that the contacts in the grooves extend from same datum,

the housing being adapted to receive at least part of the ground structure such that the tops of the walls electrically engage against the contacts in the grooves in the housing while the contacts on the fingers electrically engage against the contacts on the lands.

6. A terminator according to any one of claims 1 to 4 and further comprising:

a housing (100) having an array of lands (106)

5

10

15

20

25

30

35

40

45

50

55

60

65

with alternating slots (140) disposed between adjacent lands, a contact element (110) being disposed on each of the lands and a plate (142) on the exterior of the housing overlying at least one of the slots,

the housing being adapted to receive at least part of the ground structure such that the tops of the walls electrically engage against the plates while the contacts on the fingers electrically engage against the contacts on the lands.

7. A terminator according to any one of claims 1 to 6 and further comprising:

a casing (64) in which the ground structure (22) is partly disposed with a portion (28) of the ground structure projecting forwardly from the casing and having said plurality of walls and channels (34).

8. A terminator according to claim 7 wherein the ground structure has one or more posts (40) thereon which engage against the interior of the casing to space the ground structure from the casing.

9. A terminator according to claim 8 wherein the casing has a conductive surface (76) on the interior thereof and wherein the or each post is fabricated from a conductive material so that the conductive surface on the interior of the casing and the ground structure are in electrical contact with each other.

10. A terminator according to any one of claims 7 to 9 wherein the insulated support structure has a forward face (44F) coextensive with a forward edge of the casing.

11. A terminator for multiple electrical conductors comprising:

a metallic ground structure (22) formed of a baseplate (24) having an upper and a lower surface (30A,30B) thereon, a plurality of upstanding walls (32) extending from each of the upper and lower surfaces of the baseplate, the walls on each surface cooperating to define a predetermined number of channels (34) arranged in side-by-side relationship across each surface of the ground structure;

a first and a second insulated support structure (44) each having a body portion (46) with a plurality of forwardly extending fingers (54) thereon, one of the support structures being disposed on one of the surfaces of the ground structure, each of the fingers on each of the support structures being received in one of the channels on the ground structure; and

an electrical contact element (58) disposed on each of the fingers, each of the contact elements being connectable to one of the conductors, the tops of the walls of the ground structure being spaced above the surface thereof to a greater extent than the contact elements on the fingers are spaced thereabove so that, in use, the ground structure is connectable to a predetermined electrical potential whereby the electrical contact elements are electrically isolated from each other.

12. A terminator according to claim 11 and further comprising a housing composed of:

a body (104) fabricated of an insulating material, the body having an upper and a lower array of lands (106) each separated by an adjacent groove (108) the lands and the grooves extending substantially parallel to each other; and an electrical contact element (110,112) disposed on each of the lands and in each of the grooves such that each of the contact elements on the lands extends a greater distance toward a predetermined reference datum disposed at the center of the housing than does each of the contacts in the grooves, and such that when conjoined with the ground structure the contact elements in the upper and lower grooves respectively electrically engage against the tops of the walls on the upper and lower surfaces of the ground structure and the contact elements on the lands respectively electrically engage against the contact elements on the fingers of the first and second support structures.

5
10
15
20

13. A terminator according to claim 11 and further comprising a housing composed of: a body (104) fabricated of an insulating material, the body having an upper and a lower array of lands (106) each separated by an adjacent slot (140), the lands the the slots extending substantially parallel to each other; and an electrical contact element (110) disposed on each of the lands and an array of conductive plates (142) each overlying each of the slots such that each of the contact elements on the lands extends a greater distance toward the center of the housing than does each of the plates, and such that when conjoined with the ground structure the contact elements in the upper and lower lands respectively electrically engage against the contact elements on the fingers of the first and second support structures and the plates electrically engage against the tops of the walls on the first and second support structures.

25
30
35
40

14. A housing for a terminator comprising: a body (104) fabricated of an insulating material, the body having an array of lands (106) each separated by an adjacent slot or groove (108,140) with the lands extending substantially parallel to each other; and an electrical contact element (110) disposed on each of the lands and further contacts (112,142) in the grooves or slots or bridging or overlying same such that each of the contact elements on the lands extends a greater distance from a predetermined reference datum than does each of the further contacts.

45
50
55

60

65

8

0268441

FIG. 1.

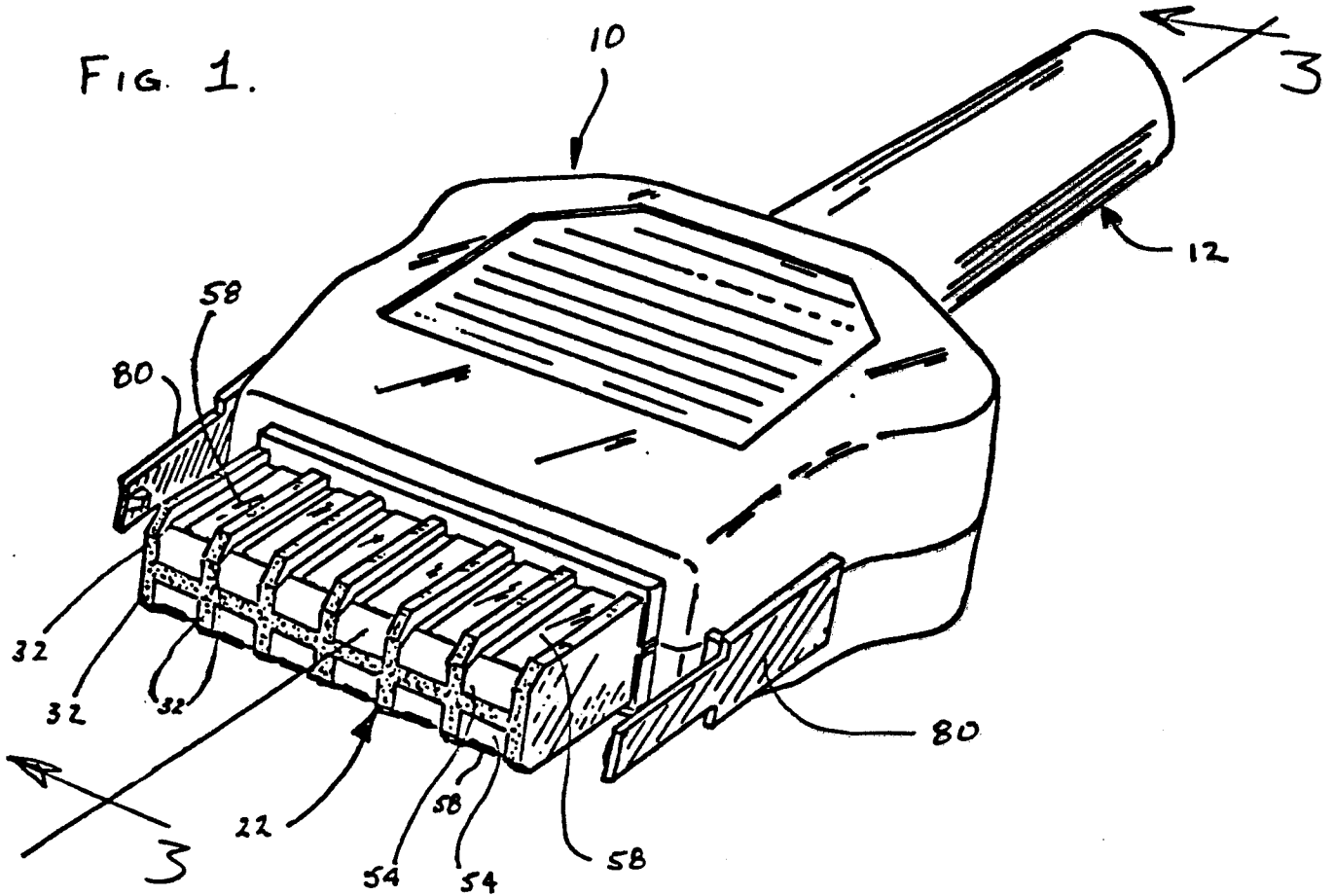
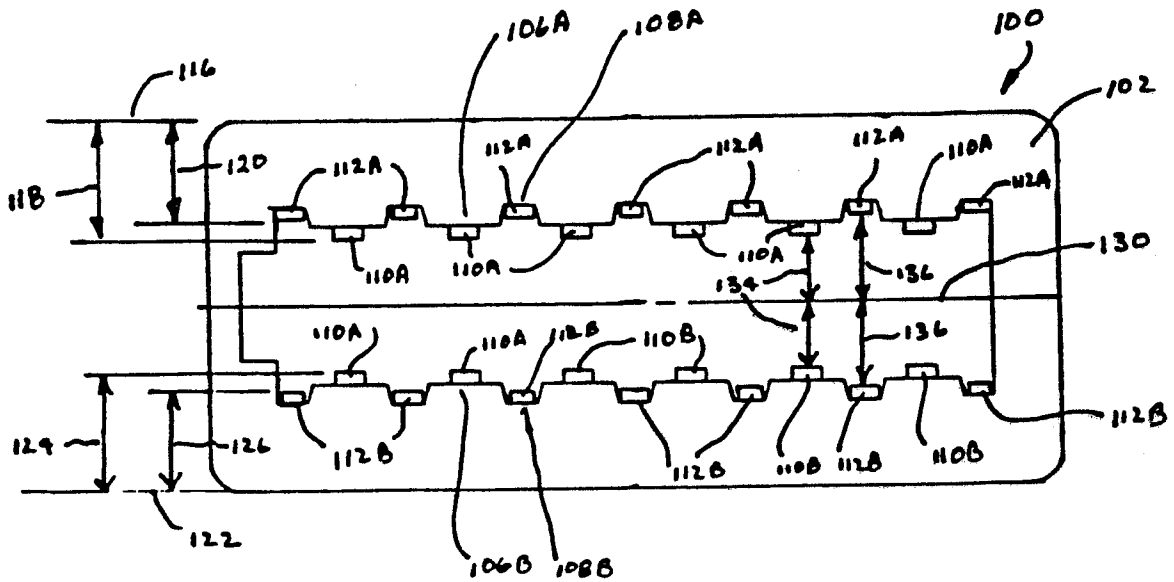

FIG. 8



0268441

FIG. 3

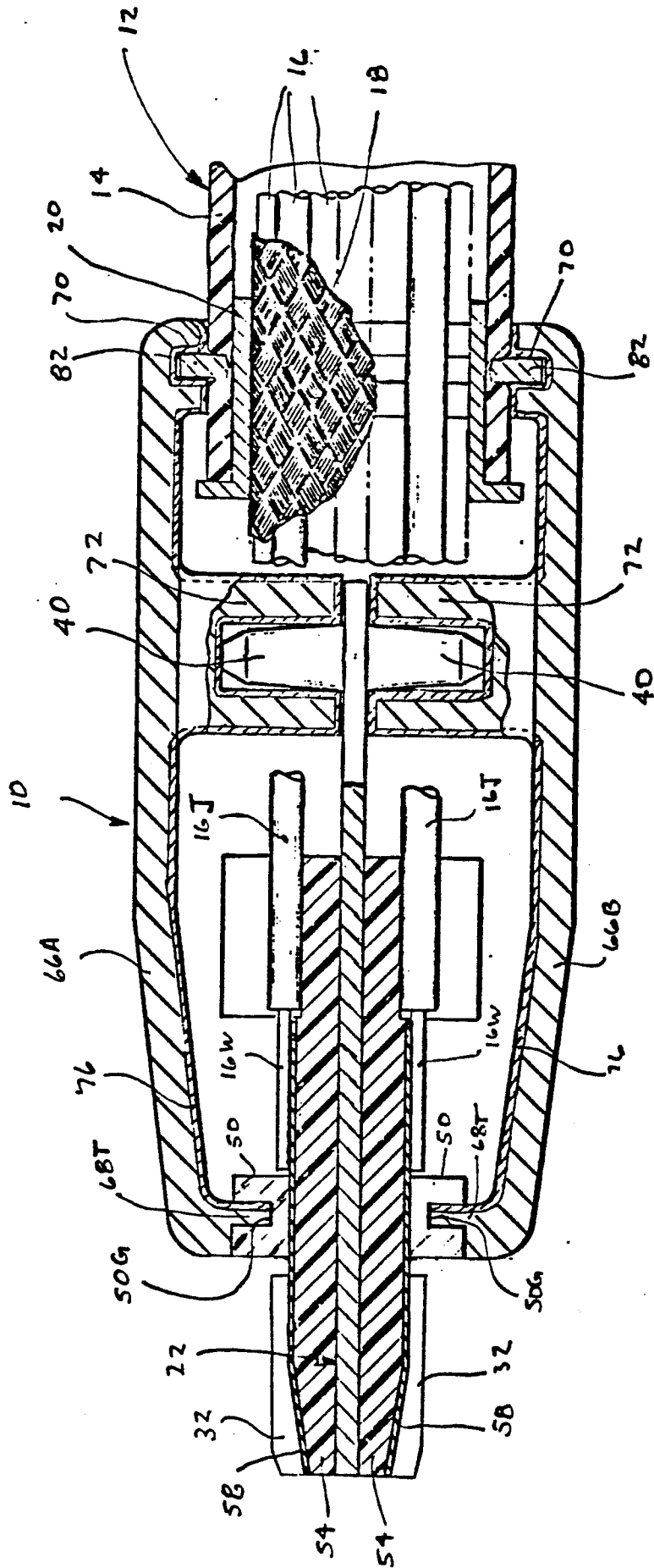
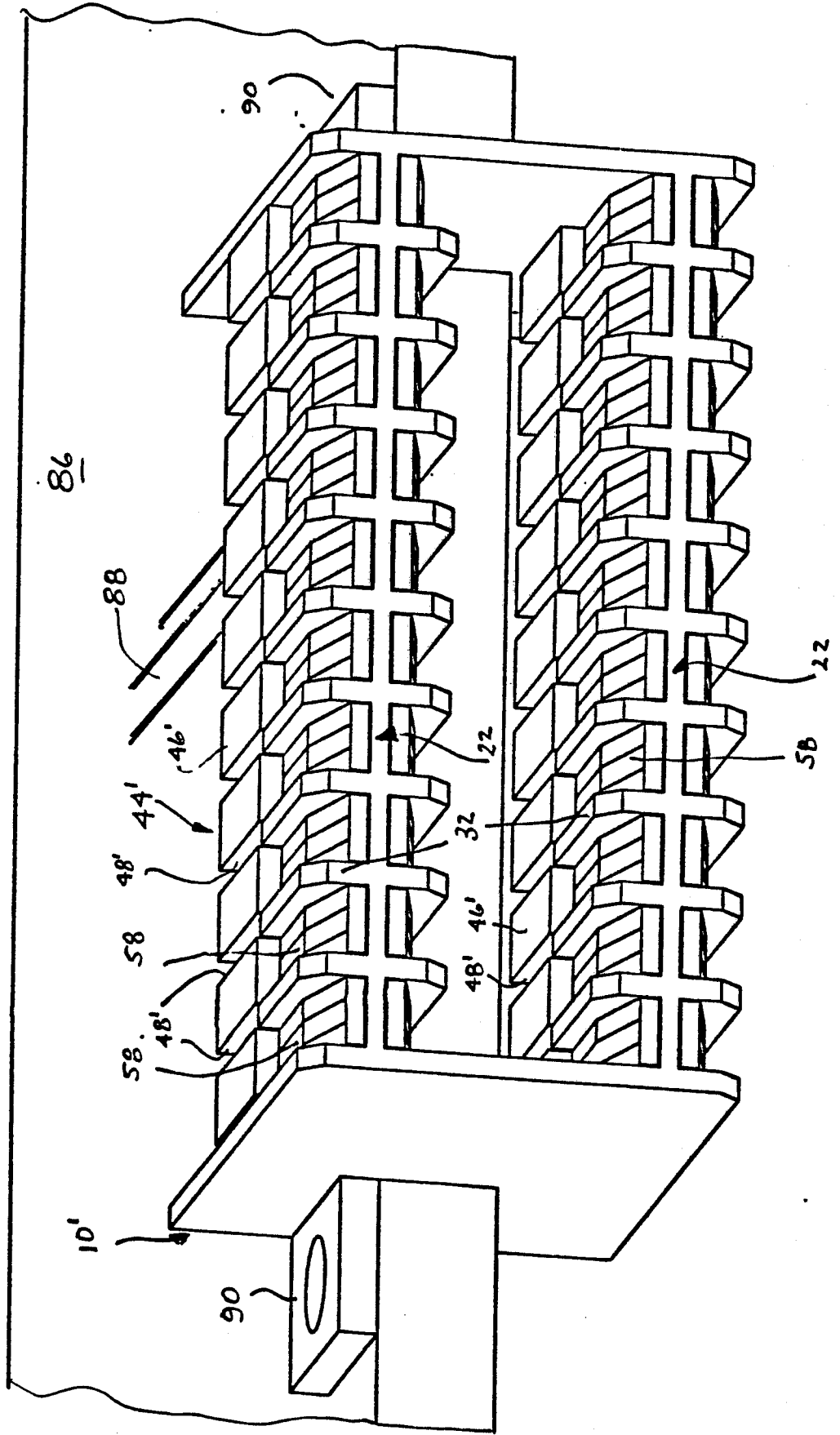

FIG. 4



0268441

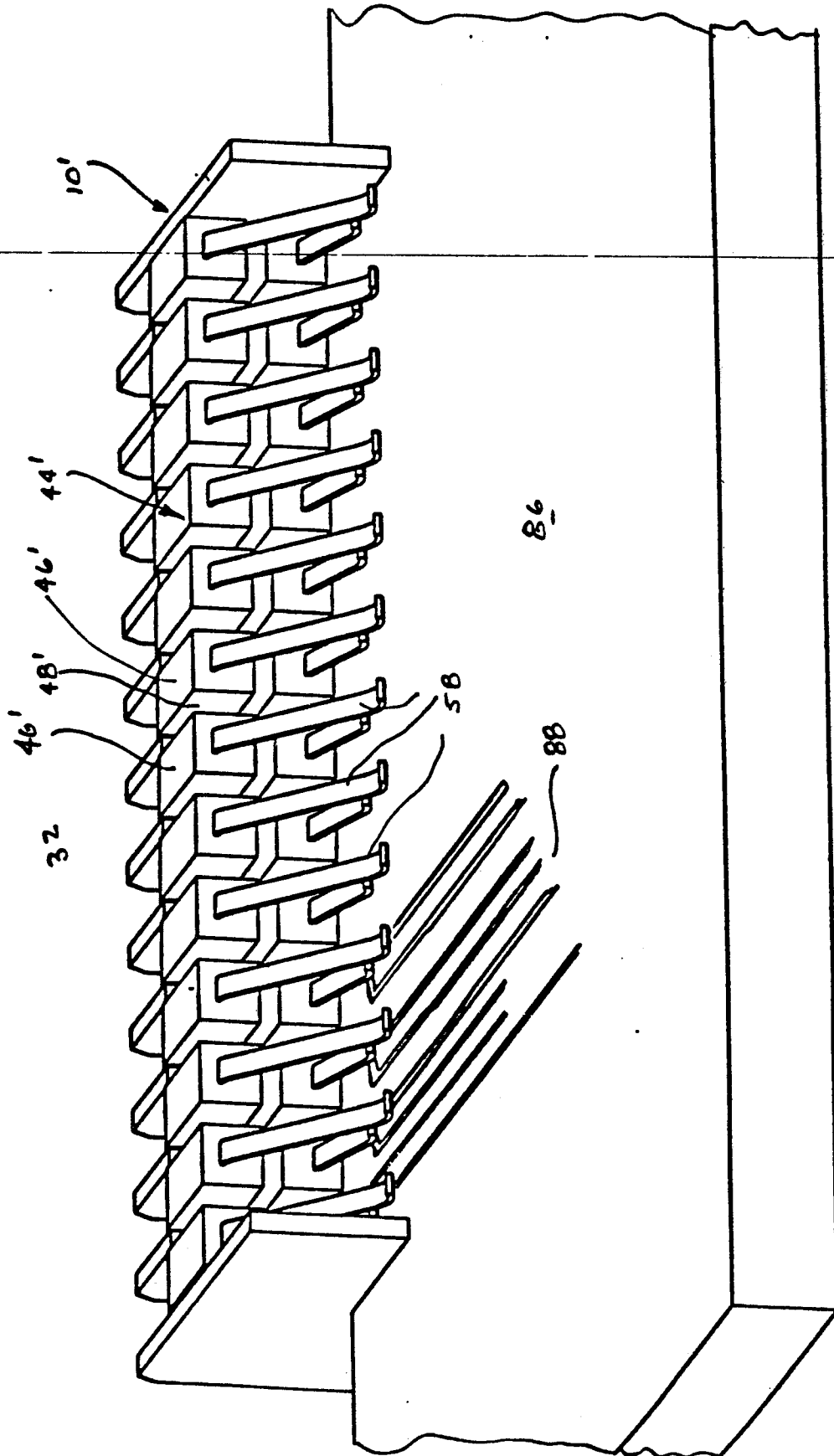

FIG. 5

0268441

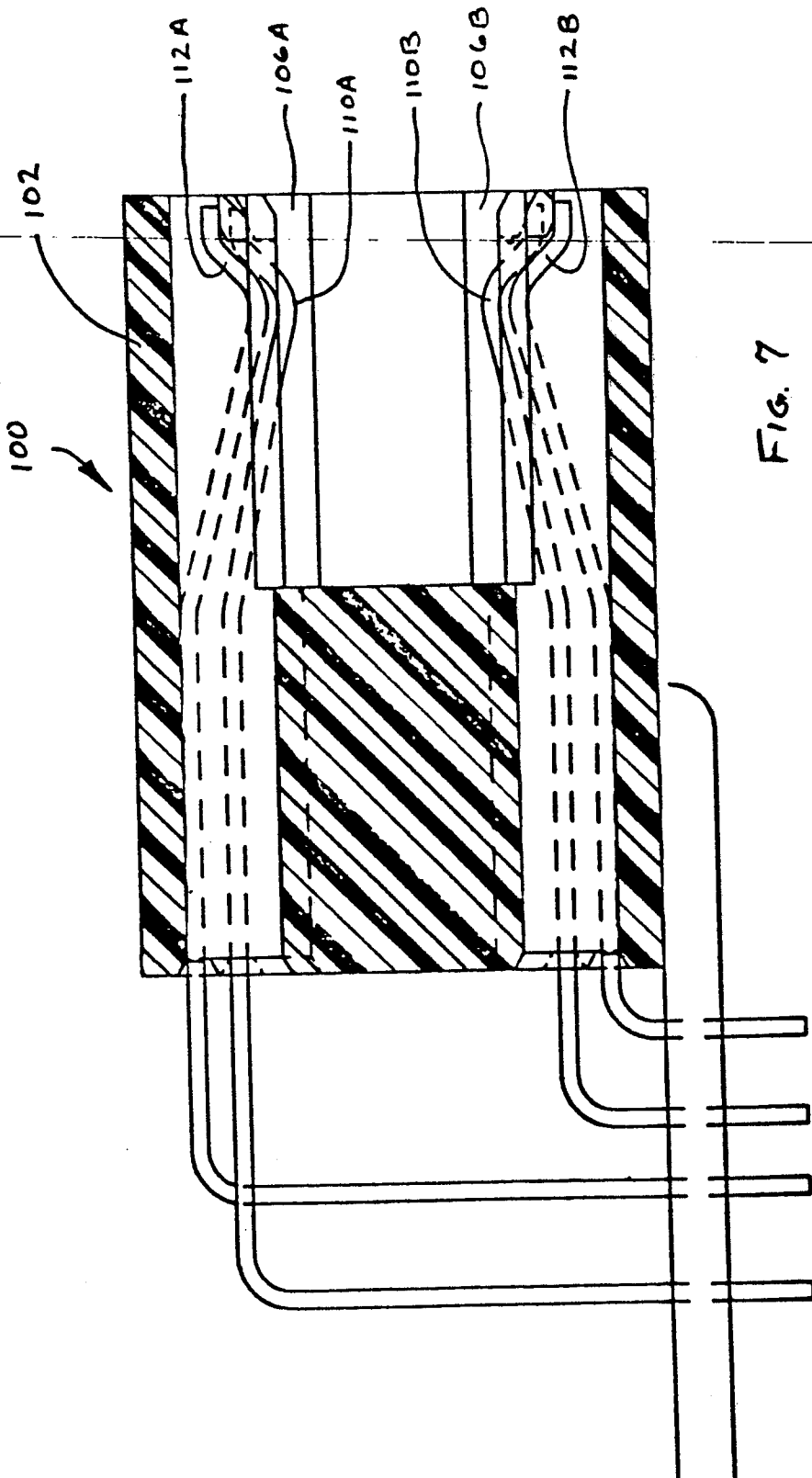
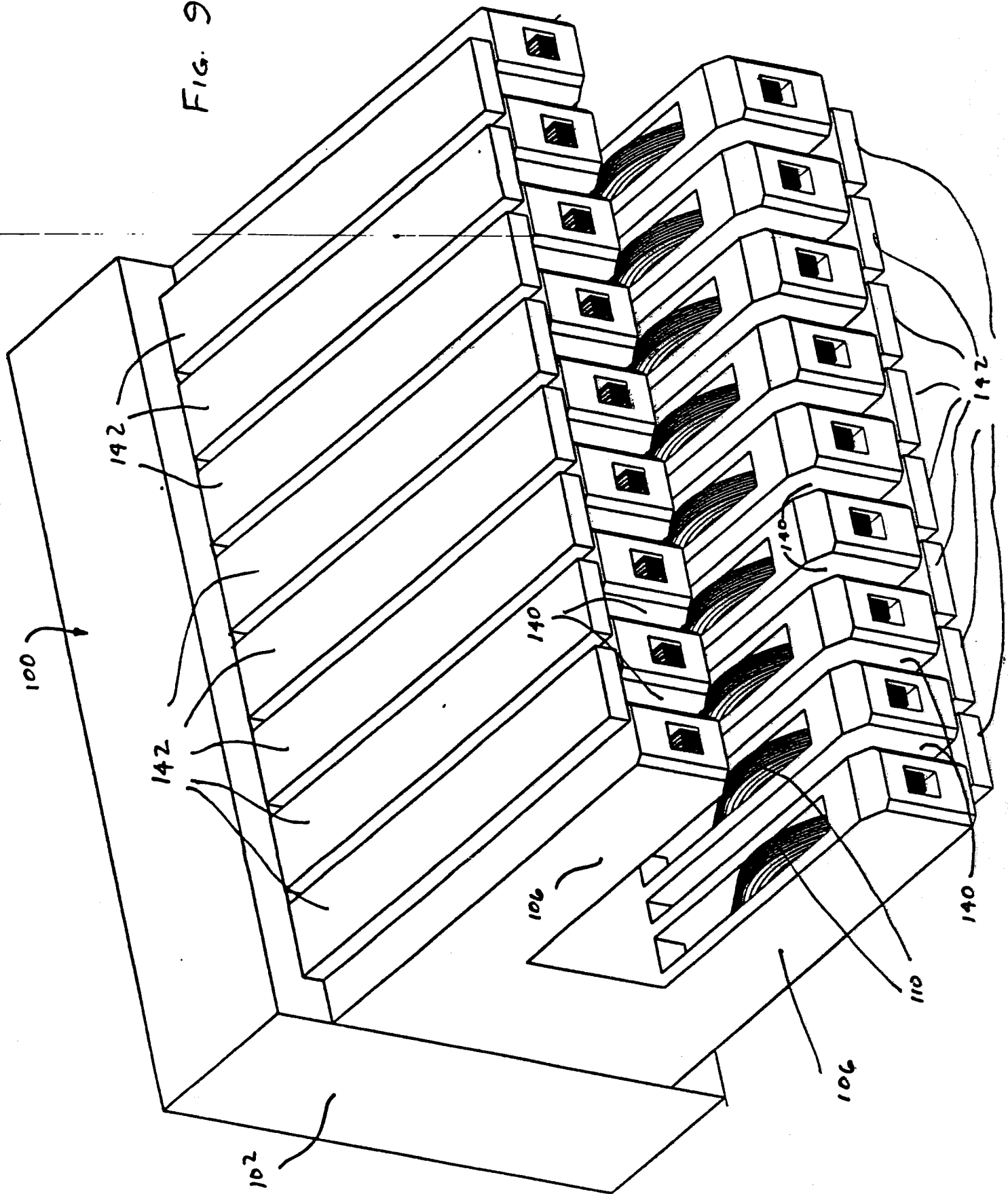

FIG. 7

0268441

FIG. 9



0268441

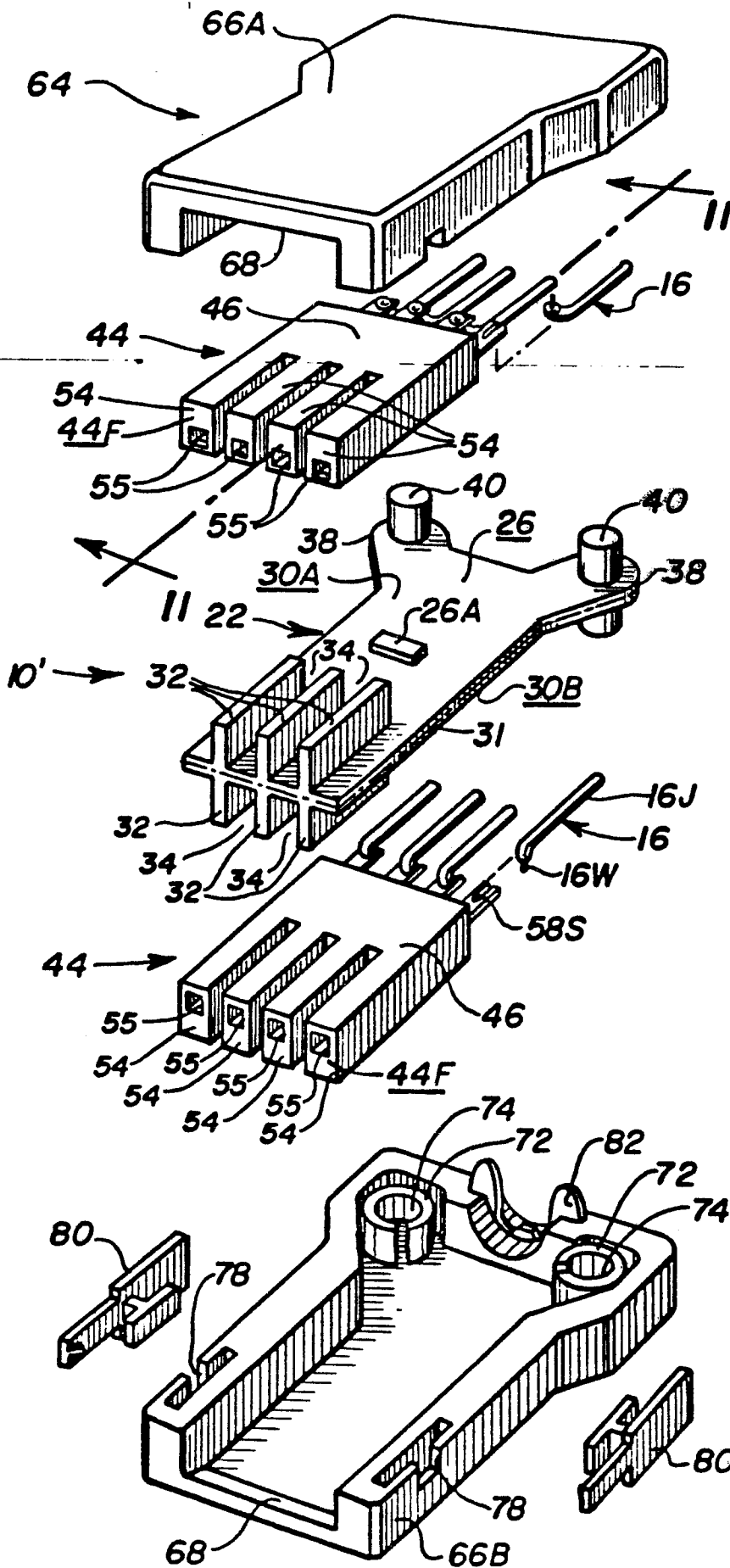

Fig. 10

