

(19) World Intellectual Property Organization
International Bureau



(43) International Publication Date
30 August 2001 (30.08.2001)

PCT

(10) International Publication Number
WO 01/63788 A2

(51) International Patent Classification⁷: H04B 3/54

(21) International Application Number: PCT/IB01/00459

(22) International Filing Date: 23 February 2001 (23.02.2001)

(25) Filing Language: English

(26) Publication Language: English

(30) Priority Data:
2,299,559 23 February 2000 (23.02.2000) CA

(71) Applicant (for all designated States except US): ONE-LINE AG [DE/DE]; Steinfeldstrasse 3, 39179 Barleben (DE).

(72) Inventors; and

(75) Inventors/Applicants (for US only): MENSING, Dirk [NL/DE]; Steinfeldstrasse 3, 39179 Barleben (DE). LANGHOF, Marco [DE/DE]; Steinfeldstrasse 3, 39179 Barleben (DE).

(81) Designated States (national): AE, AL, AM, AT, AU, AZ, BA, BB, BG, BR, BY, CA, CH, CN, CR, CU, CZ, DE, DK, DM, EE, ES, FI, GB, GD, GE, GH, GM, HR, HU, ID, IL, IN, IS, JP, KE, KG, KP, KR, KZ, LC, LK, LR, LS, LT, LU, LV, MA, MD, MG, MK, MN, MW, MX, NO, NZ, PL, PT, RO, RU, SD, SE, SG, SI, SK, SL, TJ, TM, TR, TT, TZ, UA, UG, US, UZ, VN, YU, ZA, ZW.

(84) Designated States (regional): ARIPO patent (GH, GM, KE, LS, MW, MZ, SD, SL, SZ, TZ, UG, ZW), Eurasian patent (AM, AZ, BY, KG, KZ, MD, RU, TJ, TM), European patent (AT, BE, CH, CY, DE, DK, ES, FI, FR, GB, GR, IE, IT, LU, MC, NL, PT, SE, TR), OAPI patent (BF, BJ, CF, CG, CI, CM, GA, GN, GW, ML, MR, NE, SN, TD, TG).

Published:

— without international search report and to be republished upon receipt of that report

For two-letter codes and other abbreviations, refer to the "Guidance Notes on Codes and Abbreviations" appearing at the beginning of each regular issue of the PCT Gazette.

(54) Title: A POWER LINE COMMUNICATIONS SYSTEM

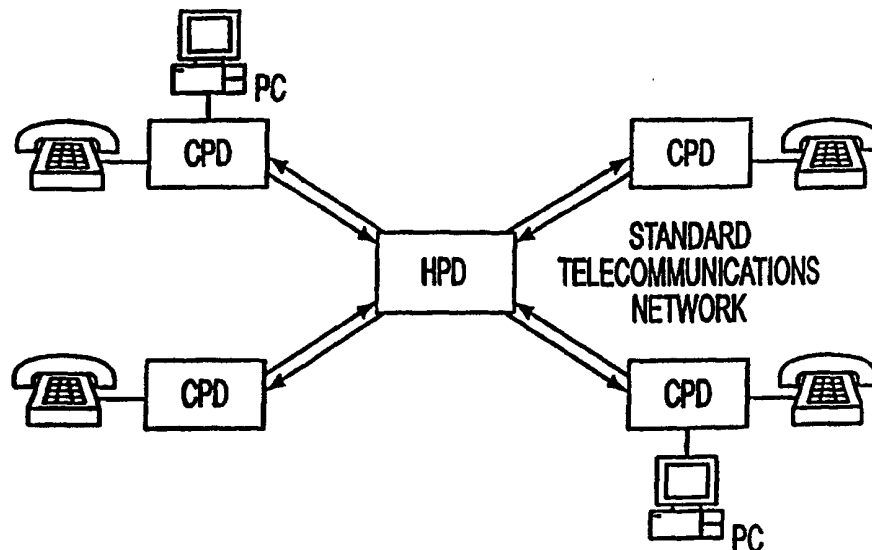

FIGURE 1: BLOCK DIAGRAM OF A LOGICAL STAR TOPOLOGY NETWORK

(57) Abstract: A power line communications system and method therefor is provided for establishing communications over a power line distribution system, such as a typical electrical distribution network. The system is characterized by a power distribution network including at least one transmission line for distributing power to consumers, a power line device configured via software as a headend power line device connected to the transmission line, and a plurality of additional power line devices configured via software as distributed customer premise devices connected to the transmission line. The power distribution network serves as a communications bus to permit communication over the network between customer premise devices and a headend power line device.



WO 01/63788 A2

A POWER LINE COMMUNICATIONS SYSTEM

FIELD OF THE INVENTION

This invention relates to a communications system, and in particular to a system capable of establishing communication over a power line distribution system, such as a
5 typical electrical distribution network.

BACKGROUND OF THE INVENTION

In the classical paradigm, most consumers are served by an electrical distribution system and some form of telecommunications system, such as the public switched telecommunications network (PSTN). These are entirely separate systems, usually run by
10 different organizations. The necessary infrastructure is costly to install and involves an inevitable amount of duplication since each system runs separate lines to each consumer.

There have been proposals to transmit communications signals over power lines, but such proposals have to date not met with much success.

SUMMARY OF THE INVENTION

15 An object of the invention is to provide an effective means of establishing communications over a power line network.

According to the present invention, a power line communications system is provided comprising a power distribution network including at least one transmission line for distributing power to consumers, a headend power line communications device (HPD)
20 connected to said transmission line, and a plurality of distributed customer premise power line devices (CPDs) connected to said transmission line wherein said power distribution system serves as a communications bus to permit communication over said power distribution system between any of said customer premise devices and said headend device.

25 The communications are preferably established as virtual connections over a cell-relay network, such as asynchronous transfer mode (ATM).

In search of an optimum method for organizing data transmission on the power line, various methods were studied. Due to the topology of the network, a bus system offers optimum conditions to meet all requirements. When defining the transmission

method, various secondary conditions had to be taken into consideration, which are essentially determined by the type of signals transmitted:

1. Communication in the power line (PL) network cells is based on a logical star at whose center a power line device (PD)—such as an HPD or CPD—
5 is arranged. The HPD provides the interface to the conventional telecommunication networks. The interface to the users of the network or to the telecommunication terminals is produced via the CPD.
2. The transmission method on the lowest plane of a PL network cell and between PL network cells is realized via a modem. Since every CPD
10 operates on a receiving frequency band that is different from the transmitting frequency band, access to the transmitting medium must be configured so as to be interference-free by means of appropriate measures.
3. The PL-bus system should be capable of transmitting voice signals of high quality. This requires maintaining specific minimum transmission rates
15 and maximum delay times.
4. The operational mode of the modem, in particular its dynamic behavior, was practically unknown. However, it had to be taken into consideration from the start that the transmission speeds that can be achieved with the
20 modem would be subject to considerable development. That is, the transmission method had to be, to a great extent, independent from the transmission speed.
5. In view of the fact that the bandwidth currently available in the PL system is rather small, a method must be selected that enables optimum use of the
25 bandwidth. The optimum must here be looked for especially between the telegram length and redundancy.
6. The problematic or unknown interference situation in the network, as well as any possible restrictions on the dimensioning of the transmitting power, requires the use of repeaters in the bus system.
7. It should be possible to realize this method at low cost while minimizing
30 the existing design risks.

The aforementioned secondary conditions finally result in the proposal of a transmission based on the cell principle, largely modeled on ATM. An advantage is that a dedicated bandwidth can be allocated to a connection. It is thus ensured that voice signals can be transmitted with the required quality.

5 BRIEF DESCRIPTION OF THE DRAWINGS

The invention will now be described in more detail, by way of example only, with reference to the accompanying drawings, in which:

FIG. 1 is a block diagram of a logical star-based network in accordance with the invention;

10 FIG. 2 shows a hierarchical bus structure;

FIG. 3 is a block diagram of a power line device;

FIG. 4 shows transmission and reception in a PL network (S - synchronous);

FIG. 5 shows device and channel addressing with VPI and VCI;

FIG. 6 shows the connection process when the HPD requests a connection;

15 FIG. 7 shows the connection process when the SU requests the connection;

FIG. 8 shows the problem of the multiple utilization of line positions;

FIG. 9 shows the bandwidths in the various zones dependent on the active SU channels;

FIG. 10 illustrates the principle of address conversion during repeating;

20 FIG. 11 shows the transmission synchronization and delay times;

FIG. 12 shows the zone structure of the network repeater power line device (RPD);

FIG. 13 shows the signaling for start-up of a CPD;

FIG. 14 shows the optimal transmitting power and repeater selection; and

25 FIG. 15 is a more detailed block diagram of a power line device.

FIG. 16 shows the general module of a power line device.

FIG. 17 shows an alternative embodiment of a hierarchical bus structure;

FIG. 18 shows a ring structure;

FIG. 19 shows a chain structure.

DETAILED DESCRIPTION OF THE INVENTION

5 It will be explained in the following how the transmission is organized in the power line system in a cell-based manner. In principle, the power line (PL) system is distinguished by the following properties:

Referring now to FIG. 1, the communications system according to the principles of the invention is arranged in a logical star system wherein the headend device (HPD) communicates over two-way communications channels with the customer premise devices (CPDs). FIGs. 2, 17, 18 and 19 shows how this structure may be arranged in a bus-based system, whether hierarchical, ring structure or chain structure, wherein the power line serves as a communications bus. Media access occurs according to a polling method. The Master is the HPD or, within a respective subnetwork, the CPD operating like a repeater.

Access to the transmission medium refers to use of a specific frequency band and, preferably, a position on an electrical distribution line, and is characterized by modem parameters. In the arrangement shown in FIG. 2, one or more line positions can be used in a zone.

20 Structure and Functionality of a Power Line Device

The general functionality of the power line device (PD) is illustrated in FIGS. 3 and 16. Generally, the power line device is used for connecting telecommunication end user devices in customers premises with telecommunications backbone structures, for connecting telecommunication end user devices in customers premises with telecommunications backbone structures and for separating and combining end user and telecommunications backbone traffic as well as for forwarding telecommunications backbone traffic to other devices of the telecommunications backbone network.

Within one integrated unit (whether at the device or chip level), the PD may combine a media specific access data repeating unit and a media specific bridging unit to

the end customer. The access data repeating unit is characterized by the fact that quasi-static connections typically can be made to two neighboring similar communication devices, data received from one neighboring communication device can be forwarded to the respective other neighboring communication device, and data relevant to end user telecommunication devices or relevant to higher level telecommunications backbone structures will be sorted out of the access data stream and forwarded via telecommunications interfaces to customer end devices, to higher-level backbone structures or to the bridging unit respectively. The bridging unit is characterized by the fact that a point-to-point or a point-to multipoint connection to other media specific end devices of the customer can be established.

Additionally, interfaces to higher level backbone structures can be integrated in the PD, as well as processing units and memory modules, a management communication unit, and one or more measurement units.

As shown in FIG. 3, the power line device consists essentially of three functional blocks:

1. The service units (SU). A service unit forms the interface to the user of the PL network. Various services are provided to the user via a SU. Telephone and data transmission services are provided directly via integrated interfaces (e.g. ISDN, POTS, etc.). These SUs integrated in the power line device (PD) are called basic service units (BSUs). External SUs (ESUs) are interfacing/bridging components to customer premise equipment (CPE) such as computers, telephones, mobile phones, web pads, televisions, etc., or other telecommunications equipment. Other services are produced when connections are made at interfaces of the PD by third parties, e.g. telecommunication company installations.

ESUs can be connected to the PD by extending the communication bus over the existing power line onto the location of the external SU (on or near a wall socket) or by other media for communications, e.g. wireless, copper wire, etc.

The bridging function of the ESUs to any other telecommunication standard will allow the connection of mobile, wireless or fixed equipment directly onto the power-data-network and thus the internet and telecommunication networks in the direct neighborhood

of the equipment.

2. The management unit (MU). This component forms the computer core of a PD, the main task of which is to manage the existing interfaces to the consumer and to the network. It is placed at a point to transfer or “hand over” a data stream from the utility owned electrical network to the electrical network of the customer premises and is characterized by the fact that a point at or near the “demarcation point” is used as signal coupling point and as electricity provision point for the MU and a metering device for electrical energy can be connected to the MU.

3. PL-Modem (PLM). The first layer (Layer 1) corresponding to an Open System Interconnection (OSI) reference model is essentially realized by the power line modem. The configuration interface is designed like an RS 232C interface and enables the MU of a PD to transfer corresponding modem parameters with which transmitting and receiving band of the modems can be defined. Although the transfer is delayed, data is delivered to the modem by the MU at the same speed as it is delivered to the PL. Moreover, the transmitting power can also be optimized via this interface.

The management of the modems also includes the channel training algorithms, carrier management, management of multiplexing algorithms and management of frequency slots. Management information can be exchanged using inband or outband communication algorithms either as a series of point-to-point connections between the different CPDs or as a point-to-multipoint communication algorithm.

The power line network is configured during a relatively complex start-up phase. At the end of the start-up, the available total bandwidth according to the local circumstances and the activated services in the respective SU is distributed to the PL network. Configuration procedures of this type must be repeated during activation of SUs, reconnection of CPDs and breakdown of CPDs.

Configuration also includes establishing a connection between a network operating system in a remote network operation center and the headend device via a higher level backbone telecommunication network; using the network operating system to perform a successive commissioning algorithm characterized by the fact that using fix defined frequency-division multiplexing (FDM) or time-division multiplexing (TDM)

procedures and parameters, a start-up connection to the neighbored device will be established and using the established start-up connection to define operating FDM or TDM procedures and parameters that are used after a re-start of the neighbored devices; and repeated usage of the procedure mentioned above to commission complete network structures as described herein.

In the following description of the basic functions, we are first proceeding on the assumption of a static, i.e. completely configured, undisturbed system.

Data Transmission Concept: Basic Principles and Access Methods

The HPD transmits a continuous stream of cells. The number of cells per time unit, or preferably the bit frequency, is thereby completely independent of the capacity utilization of the PL network. The bit frequency is defined during the start-up phase of the system and corresponds to the maximum bandwidth available in the system. Each cell, which is typically an ATM cell, consists of the usual 53 bytes that, in turn, differ by a 5-byte header and a payload of 48 bytes. The cells proceeding from the HPD form a time-division multiplex frame for the connected CPD; the CPD, in turn, transmits cells to the HPD. These time frames are allocated asynchronously to the CPD according to their communication requirement. This basic principle is shown in FIG. 4.

The HPD transmits a cell current tuned to the RPD. An explicit tuning of transmitter and receiver is not required in this case or takes place continuously during the transmitting process. Due to the topology of the network and the unknown and indeterminable interference processes on the power line, however, an additional synchronization process must be included when transmitting from the CPD in the direction of the HPD in which only one cell is typically transmitted. This is taken into consideration by the assumption that a synchronous byte (S) is placed in front of each cell. To organize both transmitting directions—from and to the HPD—symmetrically with the same channel capacity, the HPD also always inserts a synchronous byte.

These synchronous bytes are not generated by the MU, but by the PLM which also removes these bytes. Moreover, the PLM requires that the length of the synchronous flag does not exceed a byte duration.

Only connections between the HPD and the CPD are provided. Direct cross-

connections between two CPDs cannot be realized. Each cell transmitted by the HPD addresses a CPD (management information) or a SU within a CPD. It also reacts with a cell on every cell that receives a CPD. Thus, if a CPD receives a cell from the HPD, this results in a transmission authorization of this CPD.

- 5 The HPD transmits cyclically to all active SU cells. The resultant cycle can be defined as follows. A cycle describes the period in which all active SUs receive transmission authorization once. The cycle time is measured in such a way that all SUs can deposit their data in real time.

10 The number of resultant data is produced, in turn, from the required scanning rate and the signal release to the connected service. Generally, the following applies to the required bit frequency in a transmission system

$$f_b = 8z \cdot (s \cdot f_s + \frac{f_s \cdot s}{n} \cdot m)$$

or

$$f_b = 8z \cdot s \cdot f_s (1 + \frac{m}{n})$$

wherein

- 15 f_b - bit frequency
- z - number of channels in system
- s - byte per scanned useful information value
- f_s - scanning frequency
- m - management overhead per channel in bytes
- 20 n - useful information per cell in bytes

For an uncompressed voice transmission, for example, a transmission rate of 8000 frames/second at 8 bits/per channel is usual. Moreover, it can be assumed that the available bandwidth B corresponds to the maximum possible bit frequency f_b . It is known that the management overhead m results from the 5-byte cell header added together with a
25 byte synchronous information. From this point of view, a dimensional equation for the

number of channels operable in a cycle follows for the system in question:

$$z = \frac{B}{(8s \cdot f_s(1 + \frac{m}{n}))}$$

or, substituting the values above in the denominator yields:

$$Z = \frac{B}{72}$$

5 That is, for 2048 kbps, 28.44 ≈ 28 channels result.

It should be noted that the corresponding bandwidth must be available in each direction. Moreover, slight shifts can still be made here by integration of ISDN D-channel protocols. The following possibilities for better use of available bandwidths can be utilized: voice compression (e.g. to 4 bits per scanning value); unsymmetrical structure
 10 (no synchronous byte from the HPD direction) in order to realize a simplex management channel; or sacrificing transmission quality.

A channel to a SU is allocated asynchronously, i.e. if required and of course depending on availability. If the channel has been allocated, then the respective SUs are operated synchronously, i.e. also occupy the power line when there are no current data in
 15 the SU for transmission. This corresponds to the constant bit rate (CBR). More or less, this condition does not occur in voice transmissions if the cycle time is dimensioned, as just described above, such that the data delivered by a SU can just be transported away.

Addressing Concept

Virtual path identifiers (VPI), common in ATM networks, and virtual channel
 20 identifiers (VCI) are used for addressing. During the start-up phase, a VPI is allocated to every CPD and just as many VCI (>1) to each SU at a CPD, as many channels can be operated by the SUs (ISDN S0= 2 x VCI). In this way, the device, per VPI, a SU within a device is completely addressed via the VPI. VPI = 1 is reserved for the HPD. Moreover, an additional unit is found in the HPD which is only realized in software and which

intercepts all calls coming in from the power line direction. This unit contains VCI=1. FIG. 5 illustrates the principle.

Basically, the following applies: With cell transmissions from the HPD in direction of the power line, the receiver is addressed via VPI/VCI. With transmissions in
 5 reverse direction, such addressing is not required. All data must be transmitted to the HPD. For this reason, VPI/VCI in this direction contain the sender or the source of a cell.

Beyond interfaces of the HPD, an address translation of VPI/VCI is required into standard telephone numbers. These configuration data are included and managed via the component "Organizational Resource Management." A table is used in the HPD that
 10 allocates internal call numbers to the corresponding VPI/VCI. The ISDN call number system according to the ITU-T recommendation (E. 164) is used. This number, consisting of 15 digits, is used as follows for the time being:

| | | |
|----|--|----------------------------|
| | Country code | max. 3 digits |
| | Area code | max. 5 digits |
| 15 | Subscriber number Part A (External Network) | max. 4 digits |
| | Subscriber number Part B | max. 3 digits |
| | ISDN Sub-address | max. 15 digits transparent |

Therefore, 999 telephone numbers can be provided. If the HPD contacts a CPD in order
 20 to exchange management information, then it transmits a cell with VPI = devices VPI, VCI =0. For general purposes, VPI=0 is also available. Cells provided with this path identifier are read by all attached PDs. Thus, there is the possibility of transmitting broadcast cells.

Process of Establishing/Disconnecting a Connection

25 As shown in FIG. 6 and FIG. 7, a connection is established to transmit useful information (SU) or management information between HPDs and CPDs. Both processes do not differ with respect to the establishment and disconnection of a connection. A difference does have to be made between the request for a connection by a CPD or the HPD.

FIG. 6 illustrates the steps of the process when a call for a subscriber in the power line network is received at the HPD.

1. The HPD first detects from the call number VPI and VCI of the SU with which a communication is to be established. To the extent that there are still free channels available in the PL system, one of these channels is occupied with the corresponding VPI/VCI and the function message "SETUP."
2. In response, the HPD receives a message "SETUP ACKNOWLEDGE" in the subsequent cycles, the channel continues to be occupied although the connection to the end subscriber has not as yet been acknowledged.
3. While the CPD attempts to establish the connection via the addressed SU, the HPD in the corresponding channel sends the function message "CONNECTION READY?" and receives a status message "CONNECTION PENDING" or "CONNECTION ESTABLISHED" in response.
4. After the connection has been accepted by the end subscriber, this information can be forwarded to the corresponding SU of the HPD, e.g. the EI interface, which can then operate its signaling process with this information. At the same time as this is "established," a channel for the data transmission is available in the PL system.
5. Finally, the SU on the CPD terminates the conversation or the connection. The corresponding CPD then sends "DISCONNECT" on the power line. If the message comes from the HPD, then it sends the message "DISCONNECT," receives "DISCONNECT ACKNOWLEDGE" in response and thus terminates the connection, the channel is released. If the connection at the SU of the CPD is terminated, the signaling of "DISCONNECT" is sufficient.

FIG. 7 illustrates the steps of the process when a call for a subscriber outside of the power line network is received at a CPD.

1. In view of the fact that transmitting activities are not allowed for the CPD

- on its own initiative, it must first wait until the HPD requests that it transmit status information. In all free channels that are not occupied by active connections, the HPD requests all connected PDs to send their status to the HPD. If no channel is free, then, at any rate, no new connection can be established. A connection request is then not accepted.
- 5
2. The message "SETUP ACKNOWLEDGE" is sent in response to the function message "SETUP," while the signaling process takes place in the overriding network. The CPD then asks with "CONNECTION READY?" for an established connection, in response to which "CONNECTION PENDING" is sent as long as there is no connection. This cycle is repeated until it is interrupted by a "CONNECTION ESTABLISHED" message or a time-out.
 - 10
 3. After the connection has been established, the CPD begins with the transmission of data cells.
 - 15
 4. The rules set out for FIG. 6 apply for termination of the connection: depending on which device terminates the connection, a "DISCONNECT" is sufficient or it must still be answered with "DISCONNECT ACKNOWLEDGE."

The function messages are transmitted as a 16 bit code word. The other 46 bytes of a cell are available for further information. Depending on the type of message, telephone numbers, type of connection or the like are also transmitted. The HPD monitors exceeding time-out parameters in each phase of the connection.

20

Expansion of Data Transmission in n-Zones

As could already be seen in FIG. 2, the range of a HPD is increased at relatively low transmitting power by the use of repeaters. Repeaters are normal CPDs that are defined by the HPD during the start-up process. In principle, a CPD has 2 modems so that every device can be used as a repeater.

25

The first modem is used for data exchange with the HPD (or another repeater). The second modem is used for the repeating. Every repeater or RPD marks the transition into a new zone, with which no message concerning the topological situation is

30

associated. Only those signals that have their recipients in subordinated zones are regenerated. That is why the expression “repeater” should not be understood to mean the same as in network technology. In fact, this is a bridge. It is fundamentally assumed that the modem parameters/line positions preset by the HPD or a RPD may not be used again
 5 at any point in the network. Although such a multiple use of line positions is possible in principle, it does, however, require a considerable additional set-up expenditure. The basic problem is shown in FIG. 8.

The linear damping of the signal accepted there results therein that the line position is recognized as free at CPD 3. However, if CPD 3 begins to transmit on this
 10 line position, then this signal acts as interference at CPD 2. Thus, the use of a multiple utilization strategy requires extensive tuning procedures between all PDs (CPDs and HPDs). Whether a multiple utilization of bandwidth is possible can in any case scarcely be calculated in advance and depends greatly on the actual network conditions. For this reason, the following two developmental steps are realized first.

15 1. The same number of channels are offered in all zones

This method is very simple to realize. The number of channels provided by the physical layer is distributed uniformly over the zones. The following applies:

$$K_{sys} = \frac{B_{sys}}{B_k} \approx \frac{f_b}{B_k}$$

wherein

20 B_{sys} - maximum bandwidth in the system

B_k - required gross bandwidth of a channel

K_{sys} - maximum possible number of channels in the system

f_b - bit frequency

and for the channels realizable in a zone:

$$K_z = \frac{f_b}{Z} \cdot B_k$$

25

with Z number of zones in the system.

In all determinations, the effectively useful bandwidth is halved with each repeater when using this method. A differentiated observation based on an actual load to be expected does not take place. However, the method is simple to control and absolutely fair with respect to the control probability of a waiting channel.

2. Gradually provided bandwidth

In all zones n , only those channels are provided that are not already reserved for transmission according to a method to be determined in the zones $n - 1 \dots 1$. At the same time, the channels provided in zone n are not occupied in zones $n - 1 \dots 1$. Accordingly, the number of channels in the system having n zones is:

$$K_{sys} = K_1 + 2K_2 + 3K_3 \dots + nK_n$$

$$= \sum_{i=1}^n iK_i$$

with n = number of zones.

The overall channels available per zone are divided in the ratio of active terminals/SU channels. For this purpose, the formula

$$s_l = \frac{S_l}{\sum_{i=1}^n S_i} \text{ for } 1 \leq l \leq n$$

is used wherein

S_l active channels in the SU of zone 1

s_l relative portion of zone 1 in the active channels in system

S_i active channels in zone 1

A valence or quality of the individual zones may be determined from the ratio of the SU channels available in a zone to the sum of all available channels. The greater the number of SU channels available in comparison to the total number of available channels, the better the quality. Accordingly, it should also be true that there should be

proportionality between the number of SU channels and the number of useful PL channels between the zones.

$$\frac{K_q}{K_1} = \frac{S_q}{S_1}$$

If one solves this equation for K_q and uses $I = 1$ and inserts sys for K in the summation formula, then the following applies:

$$\begin{aligned} K_{sys} &= K_1 + 2 \frac{S_2}{S_1} \cdot K_1 + 3 \frac{S_3}{S_1} K_1 \dots n \frac{S_n}{S_1} K_1 \\ &= K_1 \left[1 + 2 \frac{S_2}{S_1} + 3 \frac{S_3}{S_1} \dots n \frac{S_n}{S_1} \right] \\ &= K_1 \left[1 + \sum_{i=2}^n i \frac{S_i}{S_1} \right] \end{aligned}$$

For the dimensioning of K , this results in:

$$K_1 = \frac{K_{sys}}{\left(1 + \frac{1}{S_1} \sum_{i=2}^n i S_i\right)}$$

10 Depending on how the number of active service channels are distributed in the system, a different picture results with respect to the distribution of channels.

Example 1

Two repeaters must be used in a network. The available bandwidth is 5 mbps per direction.

15 In zone 1 there are 30 active SU channels, in zone 2 there are 40 channels, and in

zone 3 there are 50 channels.

The channel number of the system is:

$$K_{sys} = \frac{5Mbps}{80kbit/s} = 64 \text{ Channels}$$

$$K_1 = \frac{64 \text{ Channels}}{(1 + 2 \cdot (\frac{40}{30}) + 3 \cdot (\frac{50}{30}))}$$

$$= 7.38 \approx 7$$

$$K_2 = \frac{40}{30} \cdot 7.38 = 9.84 \approx 10$$

$$K_3 = \frac{50}{30} \cdot 7.38 = 12.3 \approx 12$$

Thus, a distribution of the 64 available channels over the zones results as per FIG 9.

- 5 Whether a SU is occupied more or less is not considered in this procedural manner. The frequency with which a SU cannot occupy a channel is used as a standard for the adaptation of this method. This information is collected and used for evaluation and possible change of the distribution code.

- 10 If V_i is the occupation frequency in zone i , then the system having n zones is deemed optimally dimensioned when

$$V_i \approx \frac{\sum_{i=1}^n V_i}{n}$$

applies. If this is not the case, then zones having higher occupation frequency must be furnished with more channels by evaluating the situation on the basis of occupation frequency:

$$K_i = \frac{K_i \cdot n \cdot V_i}{\sum_{i=1}^n V_i}$$

Example 2

The channel numbers $K_1 = 7$, $K_2 = 10$ and $K_3 = 12$ were ascertained for a 3-zone network. After several days of operation, $V_1 = 15$, $V_2 = 45$ and $V_3 = 18$. V_2 is obviously greater. The evaluation shows:

$$K_{1'} = \frac{7 \cdot 3 \cdot 15}{15 + 45 + 18} = 4.0 \approx 4$$

5

$$K_{2'} = \frac{10 \cdot 3 \cdot 45}{15 + 45 + 18} = 17 \approx 17$$

$$K_{3'} = \frac{12 \cdot 3 \cdot 18}{15 + 45 + 18} = 8.3 \approx 8$$

It becomes clear that

$$K_1 + K_2 + K_3 = K_{1'} + K_{2'} + K_{3'}$$

10

applies or, generally

$$\sum_{i=1}^n K_i = \sum_{i'=1}^n K_{i'}$$

Any rounding errors can be avoided with this formula. The new parameters are set by the system. The counters for the occupation frequency are reset and subsequently not observed any further. As must happen often, conclusions must be inferred from the total number of calls conducted in an observation period.

15

Address Conversion in Repeaters

If a CPD is defined as a repeater, then all VPI/VCI combinations must be transferred to this device which must again be transmitted via modem 2 with modulation parameters also to be advised or received from there and to be transmitted via modem 1.

5 Every CPD has two tables per modem in which the relation between the VPI/VCI and the ports are defined via which one receives or transmits. A CPD makes three ports available:

Port 0 = modem 1

Port 1 = modem 2

10 Port 2 = local

This means that all connections existing within a CPD are made via port 2. FIG. 10 illustrates these correlations.

Delay Times and Synchronization

15 Transmitting from HPD in the direction of the PL network takes place, as described, continuously. The receiving direction of all CPDs should also be capable of detecting this signal continuously and to compensating for small fluctuations in frequency or phases. Above all, the transition to transmitting in a CPD is important for the synchronization. The synchronization of the transmitting start is made possible by the receipt of a cell intended for the MU or a SU. The following delay times occur in the

20 transmitting and receiving channel:

| | |
|--|-------------------------------|
| Delay times | Duration at $f_b =$ 2 mbps |
| Demodulation times The processes occurring in the PLM are not known in detail. However, it can be assumed that about 1 byte duration, i.e. $8 / f_b$, passes between the arrival of a bit and the output of this bit to the bit rate adaptation of the MU. In addition, the synchronous byte must be cut off. Thus, a demodulation delay of $t_{dd} = 16 / f_b$ can be expected. | 15.25 μ s |

| | |
|--|---------------------------------|
| <p>Delay due to bit rate adaptation</p> <p>The serial data flow is read in with the bit frequency f_b and first pushed through a 5-byte long slide register. This slide register is used for header synchronization since the 5th byte is compared with the remainder of module 2 division of the first 4 bytes of the header. If this so-called header error correction (HEC) agrees with the rest, then a cell start is detected. After complete reception of the cell, its bytes are transferred at a speed of 25 mbps in a byte serial manner via the bus interface to the communications processor. This transfer only takes place if a VPI that is identical to the device VPI or the broadcast VPI (VPI=0) is detected in this subassembly. The delay time is then:</p> $t_{dbc} = (m+n-1) \cdot 8 \cdot 1 / f_b + (m+n-1) \cdot 1 / f_{bus}$ <p>or in summary:</p> $t_{dbc} = (m+n-1) \cdot (8 / f_b + 1 / f_{bus})$ <p>The cell length $(m+n)$ should be reduced by 1 because it is assumed that the synchronous byte in the modem will be removed.</p> | <p>214.12 μs</p> |
| <p>Reaction Time of the MU</p> <p>After the cell has been read completely via the bus interface, the communications processor (CP) releases an interrupt. The interrupt service routine (ISR) analyzes the header, releases a decision process for the sequence with which the individual channels may send their cells and switches the task to the local further processing of the receiving data to ready. The delay time results solely from the time between interrupt and the return of the ISR. The ISR is extremely small and is programmed in such a way that it cannot be interrupted. Moreover: The cells must always be ready in the CP for the actual connections and also for the "STATUS" queries.</p> | <p>8 μs</p> |

| | |
|--|--------------|
| <p>Bit Rate Adaptation in Transmitting Direction</p> <p>The data are again incorporated in a byte serial manner via the bus interface, controlled by the CP. A speed of 25 mbps is thereby realized. The cell is converted into a bit-serial stream, the HEC is determined per modulo 2 division on the fly. The first bit at the output of the subassembly appears with the serialization, insofar as the PLM indicates ready to accept, immediately after a further pulse in bit frequency. This results in a delay of</p> $f_{dbs} = (m+n-1) / f_{bus} + 1/f_b$ | 2.59 μ s |
| <p>Modulation Time</p> <p>The synchronous byte can be transmitted immediately upon arrival of the first bit from the bit rate adaptation component. For this reason, the delay until occupation of the medium is slight.</p> | ~ 0 μ s |

The delay times thus essentially depend on the bit frequency, the speed of the bus interface, the processor frequency (ISR) and the parameters defined by the modem.

Unfortunately, it cannot be assumed that all these processes run in a determined
5 manner. It was therefore specified that the transmitting process already be started from the subassembly for the bit rate adaptation. For this purpose, one proceeds according to the following principle:

1. The header of a cell is decoded within the bit rate adaptation. When recognized (HEC = CRC (cyclic redundancy check) result), the
10 transmitting process is released one system pulse later.
2. Two transmitting buffers per modem are realized within this subassembly.
3. Buffer 1 is fed by the bus interface. The MU again decides permanently about the next transmitting cell and transfers data to this buffer when the bit rate adaptation per signal indicates ready to accept.

4. Buffer 2 always contains a status cell. This status cell is again described cyclically (about every 100 ms) via the processor or bus (60x).
5. If the bit rate adaptation recognizes a status query (VPI=device VPI, VCI=0), then the transmitting process starts from buffer 2. This is also true when there are no valid data in buffer 1 and a transmitting authorization is granted.

For this purpose, it is not necessary to respond to a cell that was sent from the HPD to a specific SU with a cell from the same SU. Only in the sum, all addressed SU channels and the MU must react in a real-time capable manner, i.e. deposit cells in direction HPD.

If transmission is started by the Field Programmable Gate Array (FPGA) of the bit rate adaptation, then this process can be considered to be determined. By interference in the modem, the decision about the media access can perhaps be relocated to layer 1. As a result, the defining methods would be simplified or become unnecessary. Due to new recognitions with respect to functioning of the modem, especially the operation of the bit rate adaptation is greatly affected. As a result, shifts of delays from one subassembly to another become possible.

FIG. 11 clearly illustrates the resultant consequences:

1. Cell A arrives at the PD and is delivered to the bit rate adaptation which decodes the header and detects a relevant VPI.
2. As per VPI/VCI, data are delivered to the modem from buffer 1 or 2. The transmitting process is released with the first flank of the data delivered to the modem. The modem sends the synchronous byte or the like.
3. The cell is delivered to the CP and the transmitting scheduler, the MU, which decides from which buffer a transmission is to take place next, is activated. If present, 48 bytes of data and a 4 byte header consisting of VPI and VCI per bus interface are delivered to the bit rate adaptation. If there are no data present, nothing happens.

The following time elapses between the arrival of a cell at the CPD and the start of

the transmitter in direction HPD:

$$t_{d-transmit} = t_{dd} + t_{dH} + 1/f_b + t_{dm}$$

where

- t_{dd} demodulation delay
- 5 t_{dH} delay until complete decoding of the header f_b
- t_{dm} modulation delay.

This, in turn, results from 40 bit times corresponding to the header length of the cell. At a bit frequency of 2 mbps, therefore, a delay time of 20.008 μ s results. The synchronous byte prevents, on receipt, conflicts between the reading in of the data in bit
 10 frequency and delivery of the data per Utopia. No data can be accepted at the modem interface while the bus interface is active. This is caused by the different pulsing at both interfaces of the bit rate adaptation. This must be taken into consideration when shortening synchronization times.

The complex, electrically inhomogeneous network requires an intelligent start-up
 15 strategy that must be suitable for forwarding PDs for utilization without great manual interruptions and, above all, without knowledge of the physical structure of the network. Any number of CPDs desired and a HPD exist in every newly constructed PL network. Since the topography and the interference situation of every network is different, all requirements must be met during start-up to maintain the communication between HPD
 20 and the CPDs under all operating conditions. At the end of the network initializations, the transition is at normal operation.

Course of the Start-up Process

The purpose of the initialization process is to ascertain optimum transmission
 25 paths within the low-voltage network that are defined by corresponding modem parameters. An optimum transmission path distinguishes itself thereby that a CPD with the necessary bandwidth is attained at minimal transmitting power. The necessary bandwidth corresponds to a standard bit rate that results from the number of channels to be operated simultaneously in a network zone multiplied by 64 kbps. If one looks at FIG. 12, it becomes clear that the maximum possible bandwidth must be available in zone 1.

Individual CPDs can be used as repeaters, as already noted. The number of repeaters should be as low as possible in the interest of minimizing additional delay times.

The initializing process starts at the HPD. Every CPD receives and sends with preset modem parameters that are distinguished by a specific line position, a very low bit rate (8 kbps) and a maximum transmitting power. It may be necessary to correct in such a way that every connected PD is securely obtained with these parameters. As a prerequisite, the HPD has the list of connected CPDs. The HPD starts after it is switched on in the unconfigured state by sending a continuous ATM cell stream in which it is addressed with a status cell ("WAKE UP") for and after every CPD. The cell stream is filled with empty cells to give the CPD time to react. For this purpose, every status command is repeated exactly after twenty empty cells. If the CPD also does not respond to the second status command, then the HPD addresses the next CPD and will again try later to address the device not obtained via a repeater to be defined. The "WAKE UP" cell contains a PDU, in addition to the function command, with the VPI that is allocated to the CPD. Since the CPD cannot as yet be addressed directly, VPI=0 and VCI=serial number of the CPD. Cells having such a header are only received during start-up. The CPD responds to the "WAKE UP" with its configuration data set and an identification number for the quality of the reception ("WAKE UP ACKNOWLEDGE").

From the configuration parameters, the HPD detects the maximum bandwidth to be provided for this CPD and reserves a corresponding number of VCIs. The PD is now requested to switch to a specific line position. For this purpose, the HPD sends a "TRANSMISSION CHECK," whereby VPI= "device VPI" and "VCI=0" is now already used. The CPD is thus advised on which line position (modem parameter for modulation, transmitting power, bit rate) it should expect a test cell stream. In addition, the configuration data for the SU (SU code, VCI, active/inactive) are found in the PDU.

The CPD must now define modem 2 on the desired line position; modem channel 1 remains in the line position for the initialization channel. The CPD quits this command ("TRANSMISSION CHECK ACKNOWLEDGE") via the initialization channel.

The HPD begins with the transmission of the test cell stream whose payload consists of significant bit combinations. The CPD permanently evaluates the bit error rate and in turn sends a test cell stream to the HPD, where the bit error rate is also evaluated.

If a transmission takes place at all, then 10,000 test cells (530,000 bytes) are sent. The HPD then queries with "TRANSMISSION RESULT," the result of the test at the CPD end. The CPD responds "TRANSMISSION QUALITY," to which the HPD redefines, if necessary, the transmitting power of the HPD and CPDs within the scope of possibilities ("TRANSMISSION CHECK"). The procedure described is repeated until an optimum transmitting power is found in which the necessary bit error rate is just obtained. If there is no transmission, then a new line position of its predefined transmission parameters (8 kbps) is defined for modem 2 via modem 1, with which the attempts to establish a transmission having the required bandwidth is repeated.

FIG. 13 illustrates the described signal play. The values established after successful conclusion of the tests for line position, transmitting power and bit frequency are stored in a configuration table within the HPD. The bit frequency is then increased and the same process completely repeated, until the maximum number of channels provided is obtained (at 2,048 Mbps as 28 channels). Finally, the HPD defines the transmitting and receiving parameters of the CPD for the operating status.

A Table is produced in the HPD for every CPD having the following form:

| Modulation | Transmitting Power | Bit Rate |
|------------|--------------------|----------|
| 00 | 32 | 1 |
| ... | ... | ... |
| 35 | 632 | 27 |

The registered values result from the allocation of firmly defined parameter sets (modulation) or from the standardization of the corresponding absolute values (transmitting power 0...1000, bit rate corresponding to number of channels). During these comprehensive tests per CPD, tests with other modem parameters and the same bit rate are also repeated with positive test results. In this way, the HPD has comprehensive knowledge with respect to the physical conditions on the power line, insofar as these have an effect on the transmission quality. If interferences occur later in a connection during the running operation, then these data can be used quickly and without new tests for

locating replacement transmission paths.

CPDs that cannot be obtained after termination of the described tests or not with sufficiently high bit rates, must be connected via repeaters.

Selecting a Repeater

5 After all parameters for the CPD have been detected within zone 1, the function of the HPD is to search for all stations which were not found with the maximum signal of the HPD or in which the error rate was not slight enough. To this end, it successively uses the stations thus far obtained as repeaters.

10 The task of the selected repeater is to regenerate the signal received in such a way that the devices not yet obtained now receive an optimum signal by division of the path length, whereby all participants attempt to minimize the transmitting power. The
15 aforementioned algorithm is again used, whereby the RPD is charged as a substitute with the transmitting and receiving of test cells through the HPD. The slow initializing and management channel remains under complete control of the HPD. A modem of the RPD
15 also remains connected with the HPD via this channel just as with the CPD which is now addressed via the RPD.

20 A repeater is defined by "REPEATER SETUP" under "VPI=Devices" VPI and "VCI=0." With this command, it receives a list of serial numbers of the CPD that are to communicate via the repeater and a VCI for the repeater. As usual, the CPD responds
20 with "SETUP ACKNOWLEDGE" and immediately begins with the known procedure for establishing a connection with the CPD (serial number list). The contact to the HPD is ensured by the slow initializing channel via which the HPD permanently requests status information from the RPD via the HPD.

25 A CPD is selected as potential repeater based on the parameters determined in zone 1. For this purpose, the average optimum power is detected in the already known network and compared with the transmitting power for obtaining the other CPD in zone 0. The average optimum power is then calculated as follows:

$$P_{opt}^- = \frac{\sum_{n=1}^m P_{opt(n)}}{m}$$

wherein m = number of CPDs obtained. $P_{opt(n)}$ = optimal transmitting power CPD - >HPD.

The deviation of the individual CPDs from the average results therefrom with:

$$\left| \Delta P_{opt(m)} \right| = P_{opt}^- - P_{opt(n)}$$

5 A sorted list of these deviations is produced and the CPD first selected as repeater that has the lowest power deviation from the average optimum transmitting power. With this, the CPD is first used as repeater that presumably lies in the central field of the obtainable network. It can thus be avoided that the border devices that are either very close or very far removed from the HPD are accidentally used as repeater. As a result, in
10 particular, a minimization of the transmitting power is obtained, at the same, options result for possible error strategies.

Activation of a new CPD

The activation of an individual CPD takes place, in principle, in the same way. As a prerequisite, the serial number of the new device is present at the HPD so that, via the
15 initializing and management channel, "WAKE UP" is cyclically sent. The new device is connected either via a repeater or directly into the PL network.

Power Line Device

A more detailed diagram of a power line device is shown in FIG. 15. This comprises a microprocessor connected to a power line interface through a Field
20 Programmable Gate Array (FPGA) to an RS 232 and 10/100 Base T Ethernet interface.

The microprocessor MPC is also connected to a RAM storing data and instructions, and flash memory Flash, and a PCI bridge.

Ports SMC 1, 2, 3 are connected to Phy interfaces, such as bus interfaces.

The PLM is connected with the basic assembly via a plug connector and mounted
25 on it as a piggyback assembly. The interface is yet to be defined structurally and with respect to the plug engagement. The PLM can be provided with 5 volts via the basic assembly. The required power is briefly specified.

| | | |
|----|------------|---|
| | RS 232 (1) | Monitor interface for inspecting logging |
| | RS 232 (2) | Configuration interface for the PLM 1 and 2 |
| | Bus 1 (1) | Data interface for the PLM 1 |
| | Bus 1 (2) | Data interface for the PLM 2 |
| 5 | SAR (1) | Alternative serial interface for PLM 1 |
| | SAR (2) | Alternative serial interface for PLM 2 |
| | Ethernet | Interface for future LAN services |
| | So(1) | Interface for local terminals |
| | So(2) | Interface for local terminals |
| 10 | EI | Interface for local terminals |

The described invention thus provides a device that can provide utilities with the ability to offer various service interfaces in the weak-current range. Standard telephone interfaces are available as service interfaces. The device makes it possible to conduct telephone conversations of standard quality via power-line connections. In addition to the
15 aforementioned functions that are made available to the user of the system, the device provides the transition from the power-line to existing networks. Depending on the arrangement of the device at a user's end or at the transition point to other networks, a distinction is made between the CPD and the HPD.

A standard ISDN telephone can be connected to a PD. If a user dials a standard
20 telephone number, then the PD establishes a connection to the desired subscriber, signals the call and busy tone to the user in the usual manner and realizes the voice transmission between the two subscribers when the connection is accepted. Instead of the connection of a standard telephone, the user can also connect a conventional extension to the PD. If data devices are connected to the telephone interface, then these devices can transmit the
25 data transparently with aid of the PD. A certain service quality (QoS), in particular bandwidth, can also be made available to the user, especially for the transparent use of the PDs for data services. The PD or all participating PDs prepare all information that is required for calculating the cost the telephone service.

In addition to voice transmission, the PD realizes the transmission of data and thus offers further operational possibilities, such as the provision of an Ethernet interface. Data and voice transmissions are differentiated at the point of the transition into other networks in such a way that they can each be delivered to other networks. It is thereby
5 irrelevant whether the data are fed into the system via a telecommunication interface (ISDN) or a data interface.

The product is used in the low-voltage range of national grids. Use is largely maintenance-free. Operation by the user is not necessary. A person/machine interface is only required to a limited degree and exclusively for trained technical personnel. Third
10 parties should not have unauthorized access to a PD or to the entire power-line network.

The PD is typically used in those areas in which the residence connections of the national grid are found. Temperature range and other parameters are to be designed accordingly.

The PD typically provides the following interfaces, in addition to the PLM
15 interfaces:

1. four European ISDN connections for the connection of telecommunication transmitting devices, especially telephone sets and telephone installations. These connections permit the establishment, operation and disconnection of up to four parallel telephone calls, to the extent that the bandwidth of
20 the overall system allows;
2. a S2M/EI connection for connection with standard telephone installations. This connection permits the establishment, operation and disconnection of up to 30 parallel telephone calls, insofar as the bandwidth of the overall system permits this and that channels are not already occupied by the
25 existing base connections corresponding to paragraph 1 above (max. 30 parallel calls per PD);
3. a 10/100 Base T Ethernet connection for connections to local area networks (LAN), wide area networks (WAN) and other networks;
4. two analog telephone connections (e.g. RJ11); and

5. an RS232 connector for maintenance and testing of the PD.

Other combinations and varieties of interfaces may be provided within the PD. The PD can also deliver fee and other information for conventional telephone systems as well as further features of the ISDN protocol.

- 5 A PD is started by connecting at the interface to the network and to the services as well as switching on the network part. The installer can then test basic device functions via the RS 232 service interface. Moreover, the installer must determine whether the PD is used as a HPD. If necessary, corresponding software modules are added to the equipment software via a service interface. Optionally, it is checked whether the software
- 10 of the HPD and standard PD have room in parallel in a device. In this case, every PD should operate as a CPD if it is not defined as a HPD via the service interface.

The network is started without knowledge of the network topology, the interference situation and other physical variables. However, it is assumed that all PD and the HPD are installed properly. The goal of this initializing process is to ascertain the

15 optimum transmission paths within the low-voltage network that are defined by appropriate modem parameters. An optimum transmission path is distinguished thereby that a PD having the necessary bandwidth is obtained at minimum transmitting power. The necessary bandwidth corresponds to a standard bit rate that results from the number of channels to be operated simultaneously multiplied by 64 kbps. The fact that it is in the

20 start-up mode can be ascertained by an LED on a PD. If use of the network is not possible to the desired extent (number of PDs or users), then this information must be provided for evaluation. Every PD has two transmitting and receiving units independent of one another with 2 power-line modems. The function of a PD as a HPD or consumer PD is defined by the firmware.

25 Behavior of the PD when configured as an HPD

The HPD realizes various processes that are suitable for defining transmission paths and which are to be redefined when there are dynamic changes in the network "on the fly." It has master functionality for all communication processes.

Behavior of the PD when configured as a CPD

- 30 Under the guidance of the HPD, the PD can be adjusted with respect to modem

parameters. Every PD can, in addition, assume the function of a repeater.

A connected telecommunication transmitting device reacts as usual in today's telecommunication networks. After lifting the receiver, a dial tone is emitted by the PD. The user dials a telephone number. After the dialing process is completed, the system
5 attempts to establish a connection for the user. This first takes place via the internal, i.e. power line, network and then via HPD in existing standard telecommunication networks. If the connection is successfully established, then the ring signal is transmitted as usual to the user. If no connection can be provided within or outside of the power-line network, then the user receives a busy signal. A telephone connection is realized with good quality
10 comparable to an ISDN connection. The power line is subject to strong dynamic interferences as known from conventional telecommunication networks or other networks. For this reason, the components (HPD and CPD) participating in a connection must also react dynamically to interferences and also switch to alternative transmission paths without considerable interferences during established connections.

15 After the connection is terminated by the user, all transmission channels are disconnected securely.

The service made use of by the user is recorded accurately. These call data are transmitted via the telecommunication network to a external data bank server.

It can be seen by the LED on a PD that it is in the normal mode.

20 The PLM is provided with a bit serial data flow, divided into transmitting and receiving direction, or an interface corresponding to Bus 1 as a data interface.

The modem parameters, bit rate and transmitting power are defined via a RS232 or another interface that should be specified briefly.

We claim:

1. A power line communications system characterized by:
 - a power distribution network including at least one transmission line for distributing power to consumers,
 - 5 a power line device configured via software as a headend power line device connected to said at least one transmission line, and
 - a plurality of additional power line devices configured via software as distributed customer premise devices connected to said at least one transmission line,
 - wherein said power distribution network serves as a communications bus to
 - 10 permit communication over said network between any of said customer premise devices and said headend power line device.
2. The power line communications system of claim 1, wherein said customer premise devices provide an interface via an internal electrical wiring system to at least one external service unit in communication with customer premise equipment.
- 15 3. The power line communications system of claim 1, wherein said power line device configured as a head end device provides an interface with a telecommunications backbone.
4. The power line communications system of claim 1, wherein a group of said customer premise devices is connected to a repeater device connected to said network.
- 20 5. The power line communications system of claims 1 or 4, further characterized by a dedicated repeater device.
6. The power line communications system of claims 1, wherein at least one of said customer premise devices additionally serves as a repeater device.
7. The power line communications system of claims 4, wherein at least one of said
- 25 customer premise devices additionally serves as said repeater device.
8. The power line communications system of claim 1, wherein said headend power line device additionally serves as a repeater device.
9. A power line communications system as claimed in any of the preceding claims,

wherein virtual connections are established between said headend power line device and any of said customer premise devices to permit communication therebetween.

10. The power line communications system of claim 9, wherein said virtual connections of said network are established in a hierarchical configuration.

5 11. The power line communications system of claim 9, wherein said virtual connections of said network are established as a chain structure.

12. The power line communications system of claim 9, wherein said virtual connections of said network are established as a ring structure.

10 13. The power line communications system of claim 9, wherein said virtual connections are established via data carrying cells transferred over said network.

14. The power line communications system of claim 13, wherein said cells are asynchronous transfer mode cells.

15. A method of establishing communications over a power distribution network characterized by:

15 connecting a power line device configured via software as a headend power line device to a transmission line for distributing power to consumers,

connecting additional power line devices configured via software as customer premise devices to said transmission line at distributed locations,

20 establishing communications between any of said customer premise devices and said headend power line device using said power distribution network as a communications bus.

16. The method of claim 15, wherein any of said power line devices can be configured to serve as a repeater device to any neighboring power line device.

25 17. The method of claim 15, wherein any of said power line devices can be connected to said transmission line at any point in said power distribution network.

18. The method of claim 17, wherein said connection is provided at a mid-voltage position in said network.

19. The method of claim 17, wherein said connection is provided at a low-voltage

position in said network.

20. The method of claim 17, wherein said connection is provided within a customer premise in said network.

21. The method of claim 15, wherein virtual connections are established within said
5 network to permit communications within said network.

22. The method of claim 21, wherein said virtual connections are managed by inbound management.

23. The method of claim 21, wherein said virtual connections are managed by outbound management.

10 24. The method of claim 22, wherein said outbound management is point-to-point communication.

25. The method of claim 22, wherein said outbound management is point-to-multipoint communication.

15 26. The method of claim 21, wherein said virtual connections are asynchronous transfer mode connections.

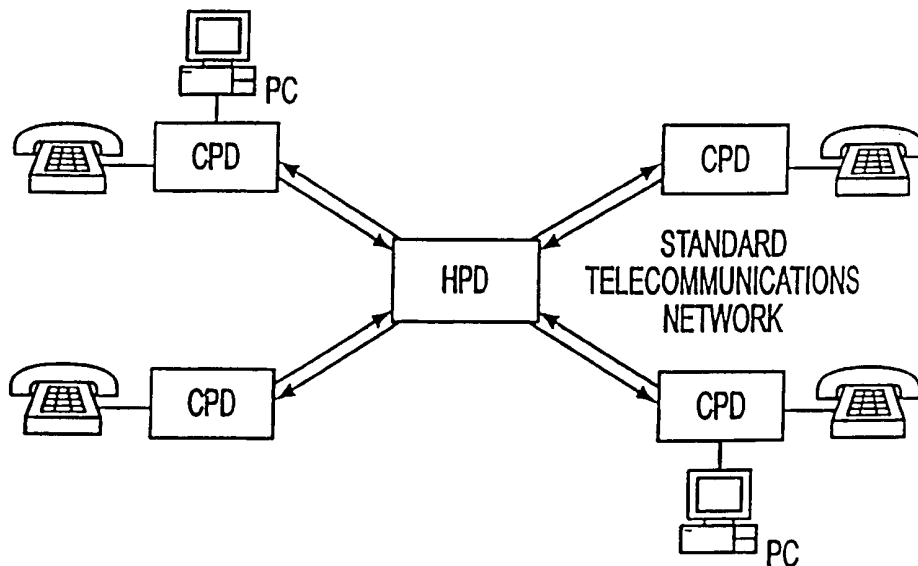

FIGURE 1: BLOCK DIAGRAM OF A LOGICAL STAR TOPOLOGY NETWORK

FIG. 1

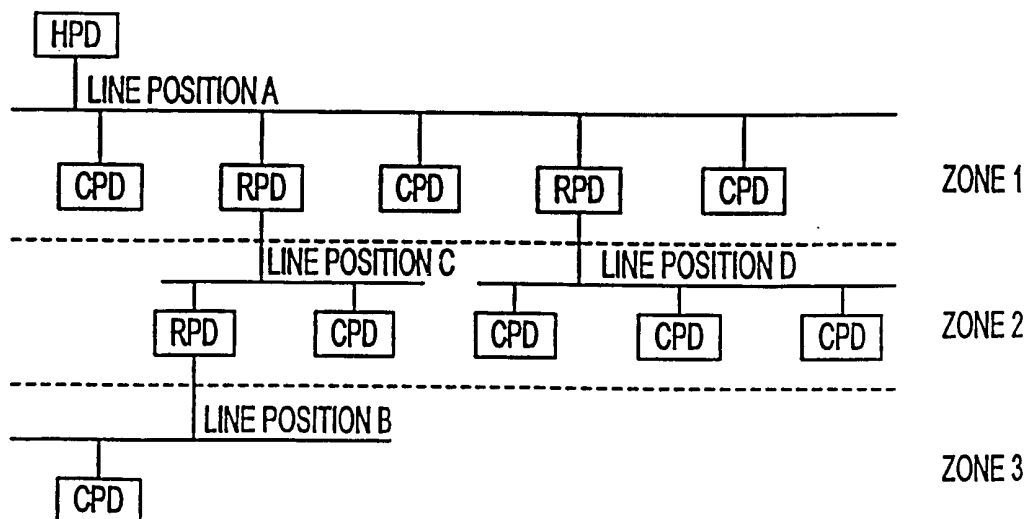

FIGURE 2: HIERARCHICAL BUS STRUCTURE OF THE PL-SYSTEM (RPD REPEATER POWERLINE DEVICE)

FIG. 2

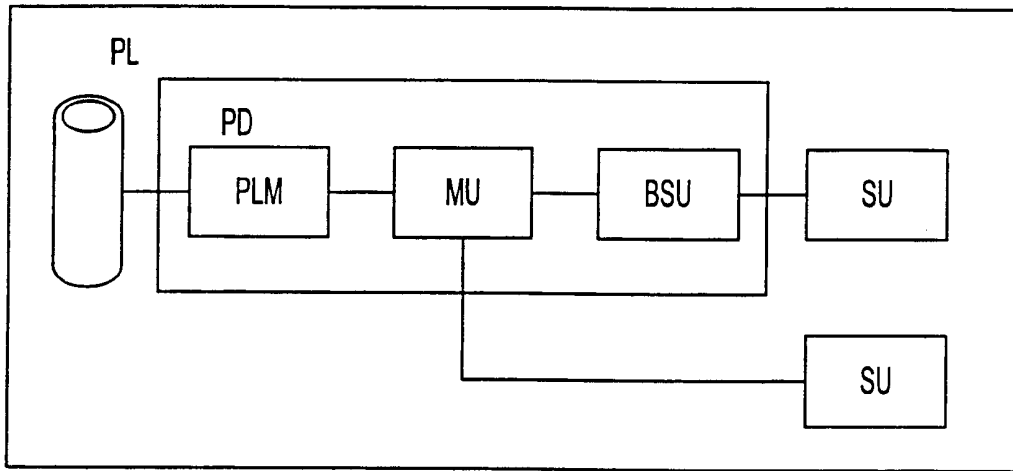

FIGURE 3: STRUCTURE OF A POWERLINE DEVICE (PLM-POWERLINE MODEM, MU-MANAGEMENT UNIT, BSU-BASIC SERVICE UNIT, SU-SERVICE UNIT)

FIG. 3

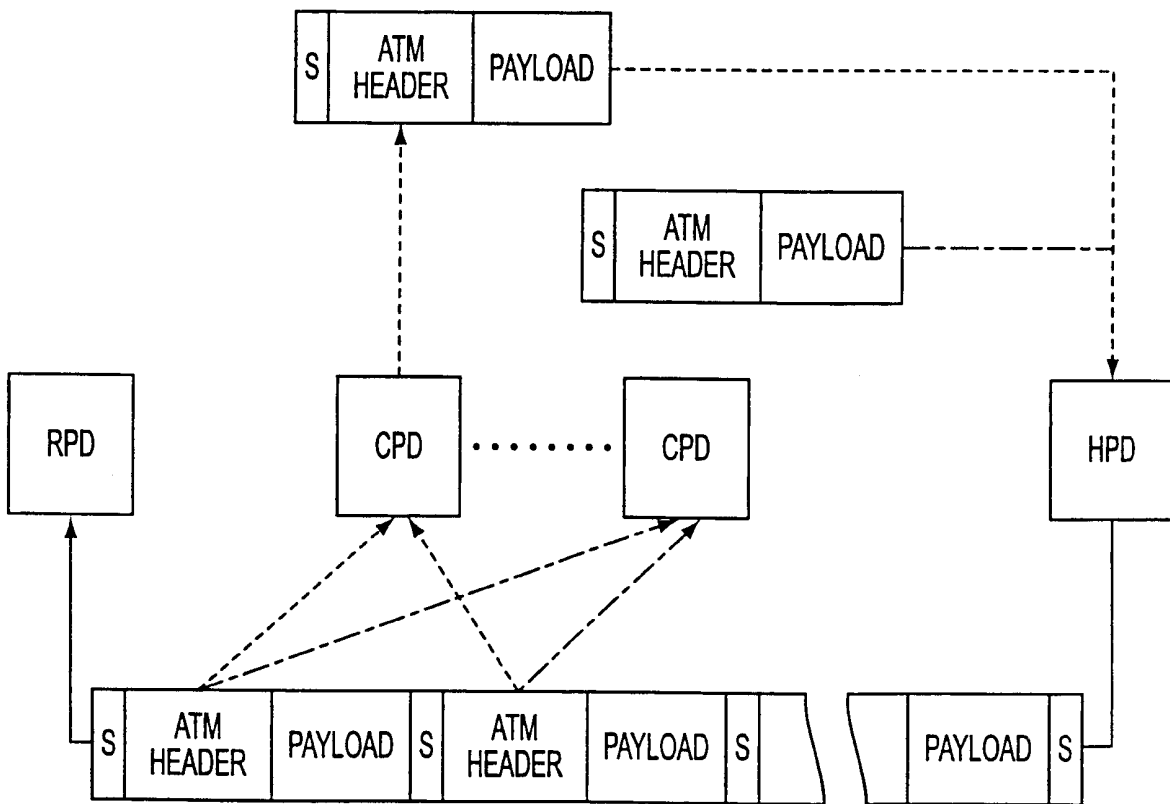

FIGURE 4: TRANSMIT AND RECEIVE IN THE PL-NETWORK (S-SYNCHRONIZATION)

FIG. 4

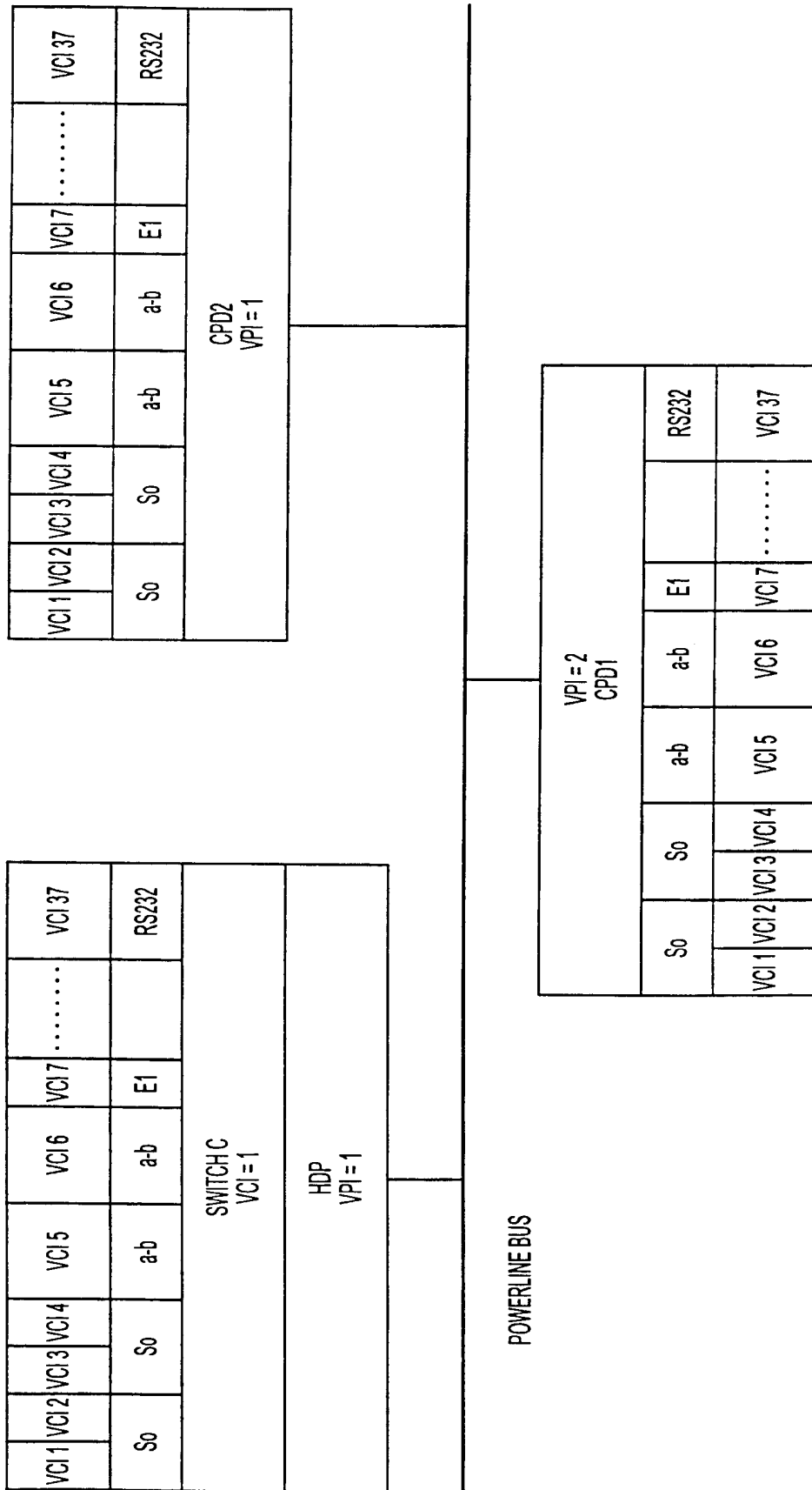

FIGURE 5: DEVICE AND CHANNEL ADDRESSES WITH VPI AND VCI

FIG. 5

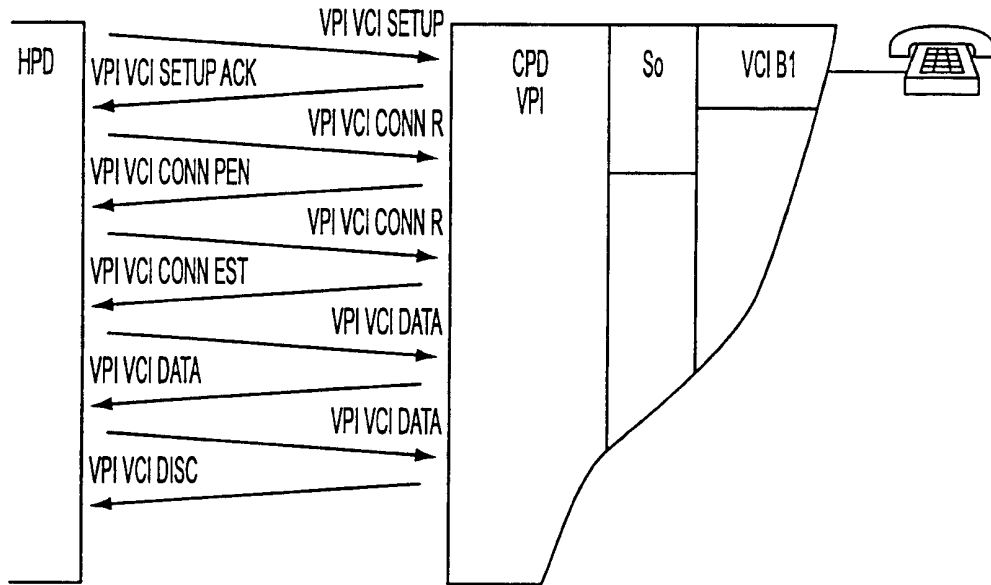

FIGURE 6: CONNECTION PROCESS WHEN THE HPD REQUESTS A CONNECTION

FIG. 6

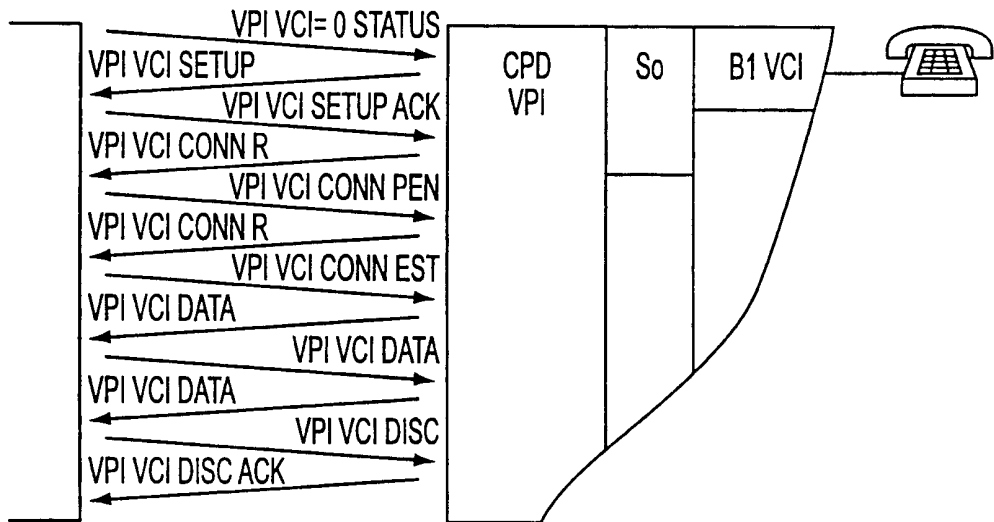

FIGURE 7: CONNECTION PROCESS WHEN THE SU REQUESTS A CONNECTION

FIG. 7

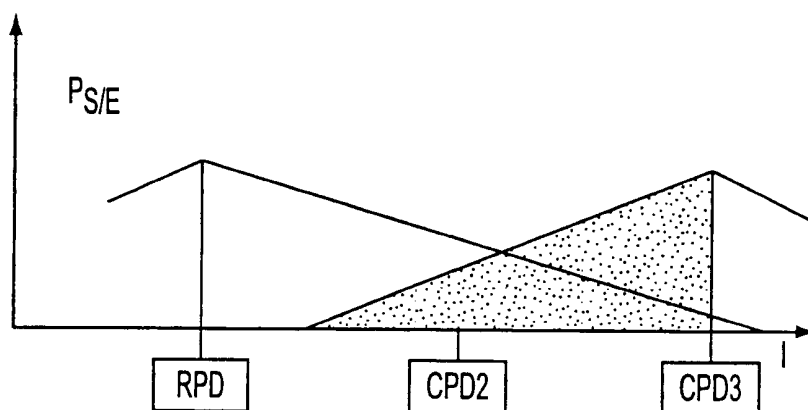

FIGURE 8: PROBLEM OF MULTIPLE UTILIZATION OF LINE POSITIONS

FIG. 8

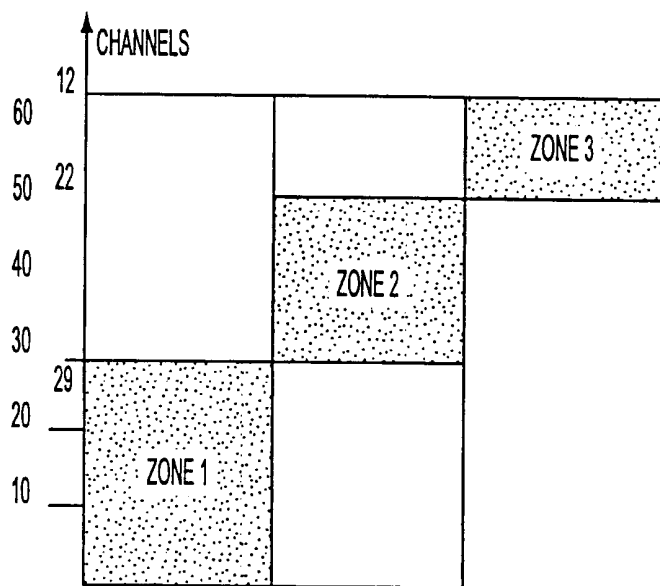

FIGURE 9: BANDWIDTHS IN THE VARIOUS ZONES DEPENDENT ON THE ACTIVE SU CHANNELS

FIG. 9

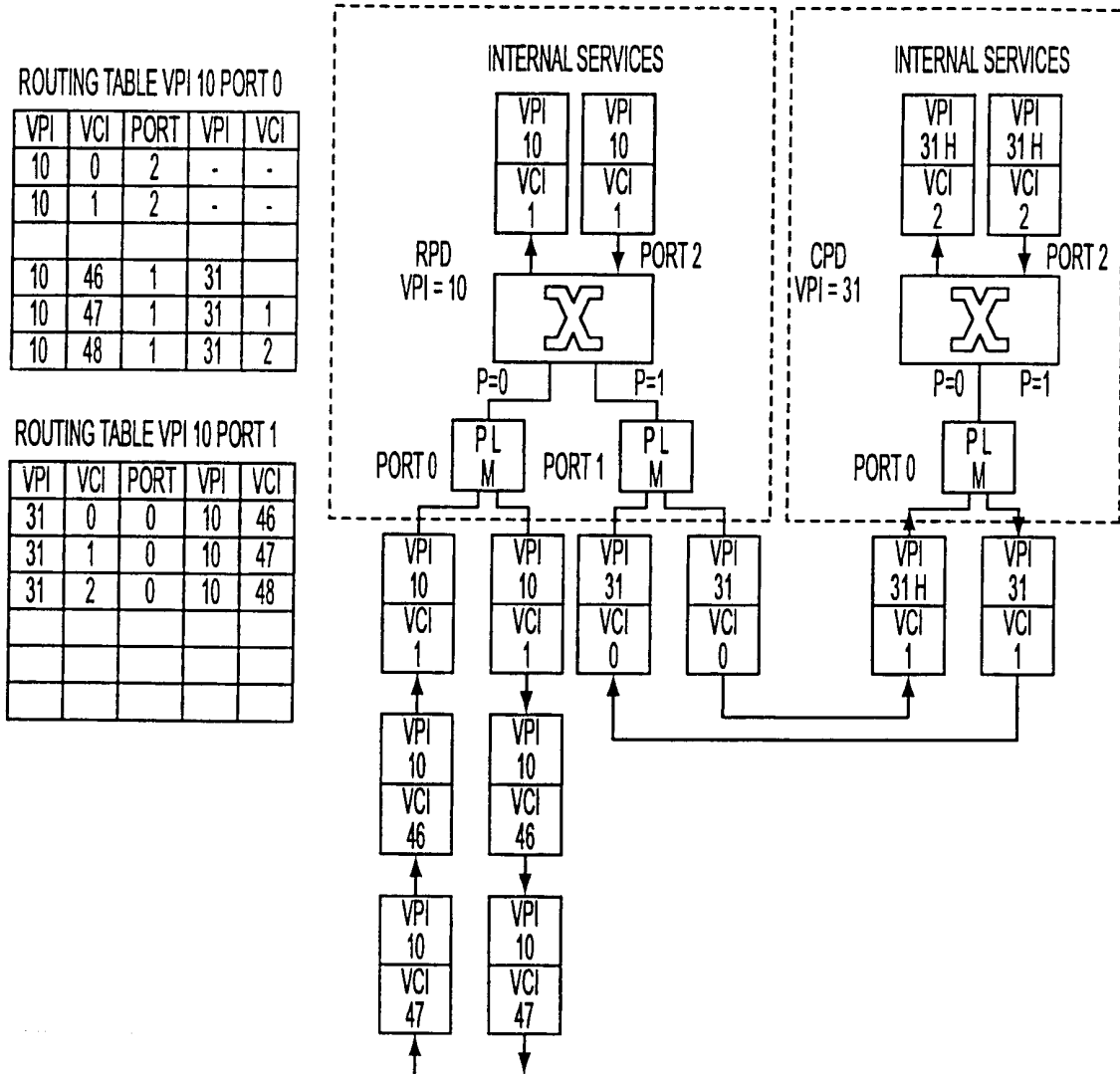

FIGURE 10: PRINCIPLES OF ADDRESS CONVERSION DURING REPEATING

FIG. 10

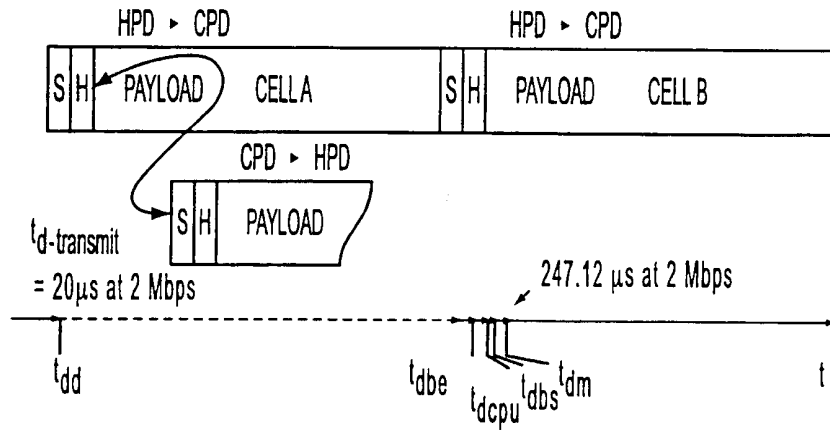

FIGURE 11: TRANSMISSION SYNCHRONIZATION AND DELAY TIMES

FIG. 11

INITIALIZATION PROCESS PROCEEDS FROM THE HPD.
EACH CPD RECEIVES AND TRANSMITS WITH PRESET

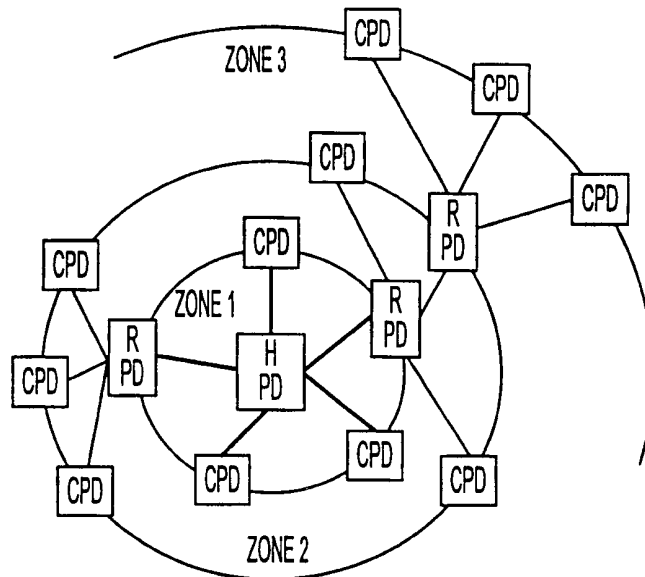

FIGURE 12: ZONE STRUCTURE OF THE NETWORK
(RPD-REPEATER POWERLINE DEVICE)

FIG. 12

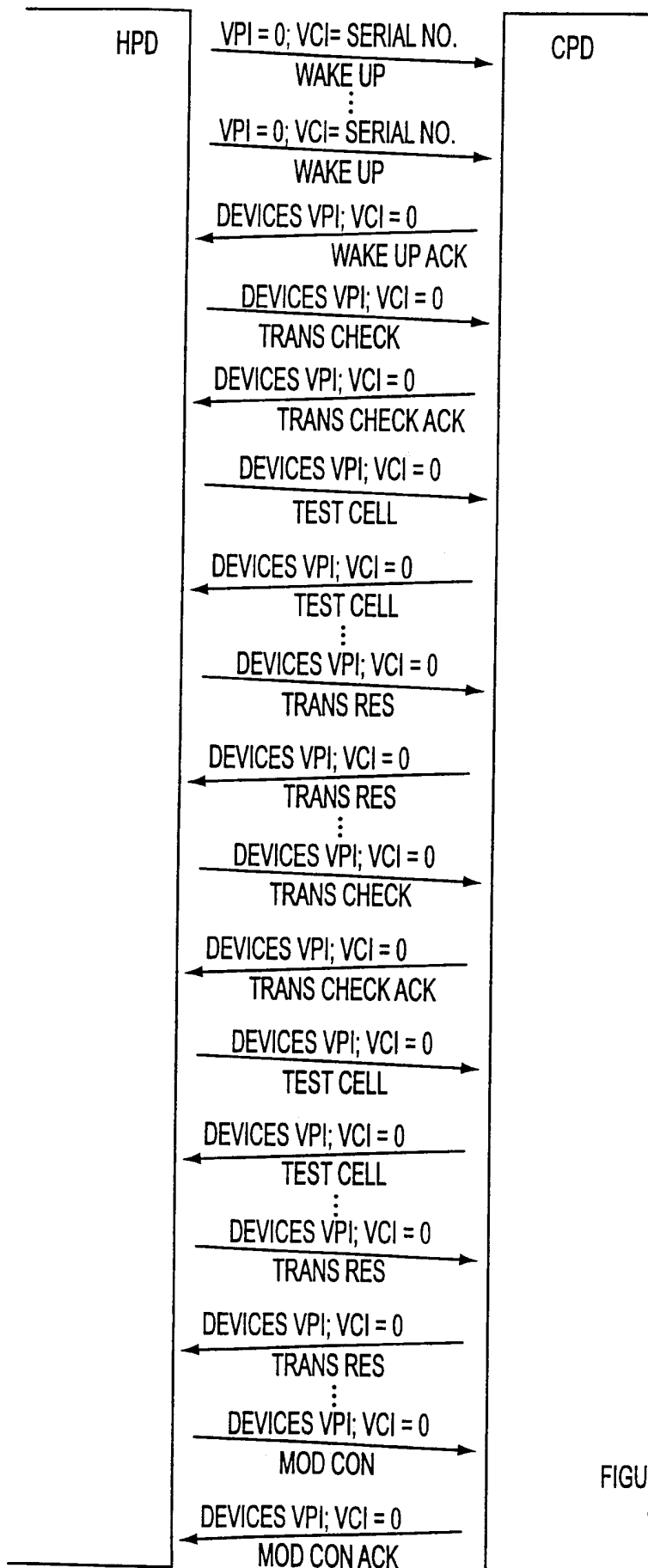

FIGURE 13: SIGNALLING FOR STARTUP OF A CPD

FIG. 13

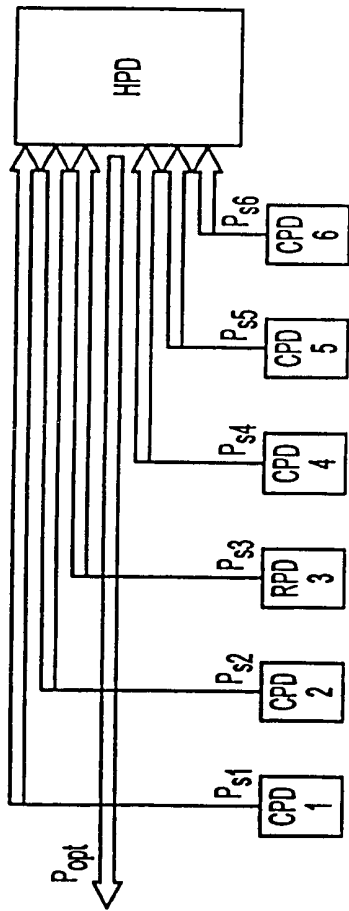

FIGURE 14: OPTIMAL TRANSMISSION POWER AND REPEATER SELECTION

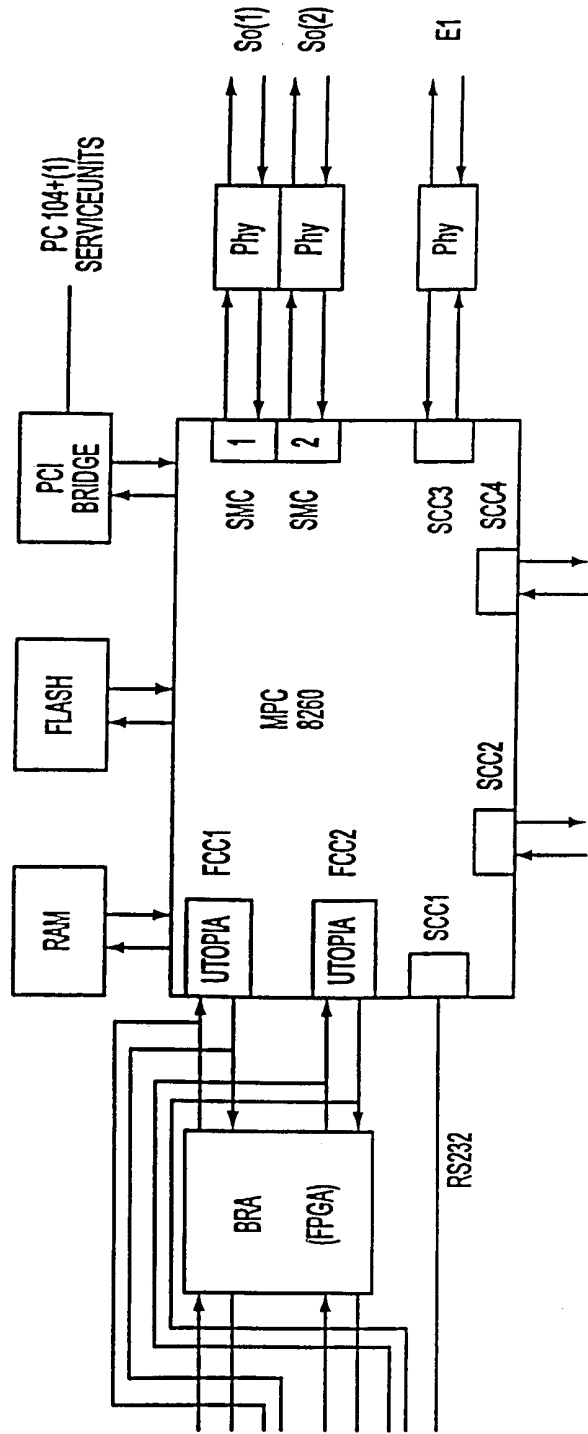

FIGURE 15: LOGICAL CPU STRUCTURE

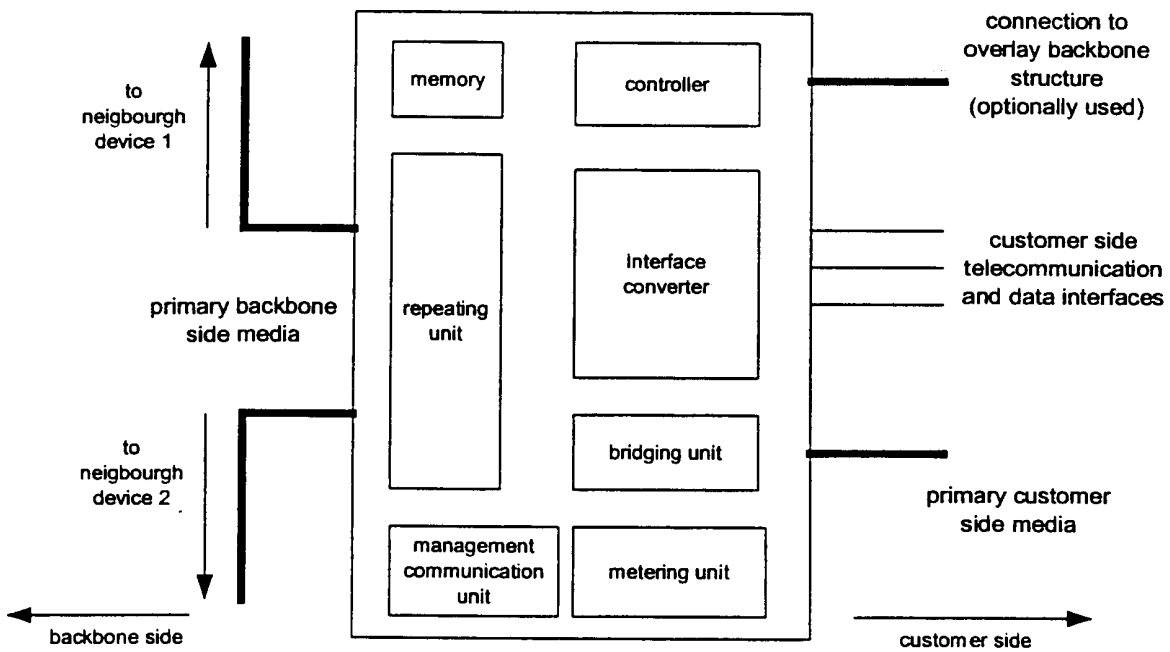

FIG. 16

Hierarchical

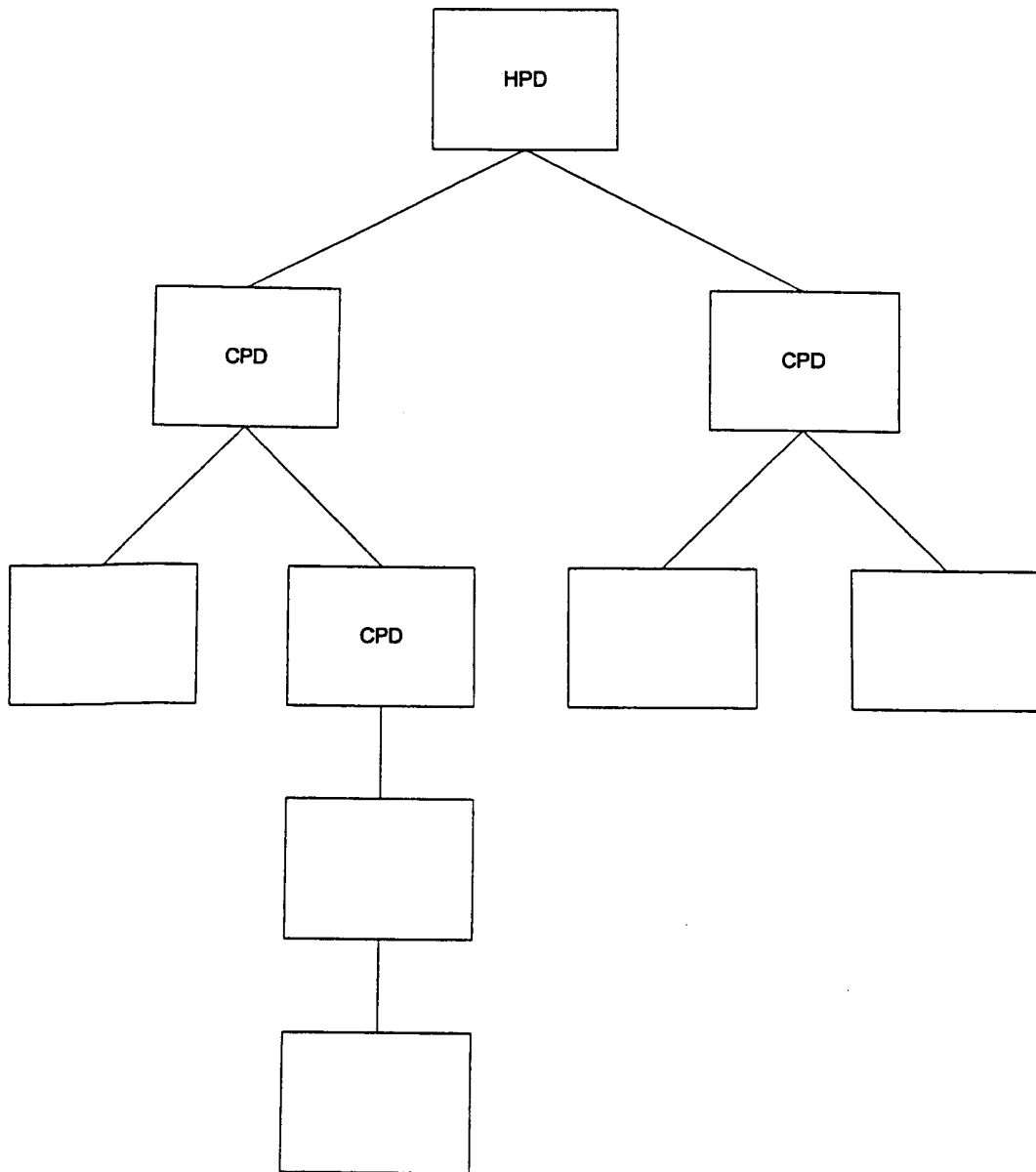

FIG. 17

Ring Structure

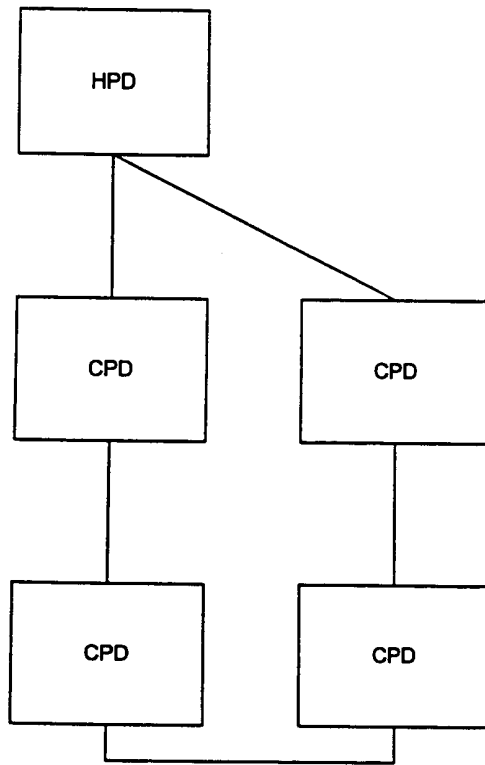

FIG. 18

Chain Structure

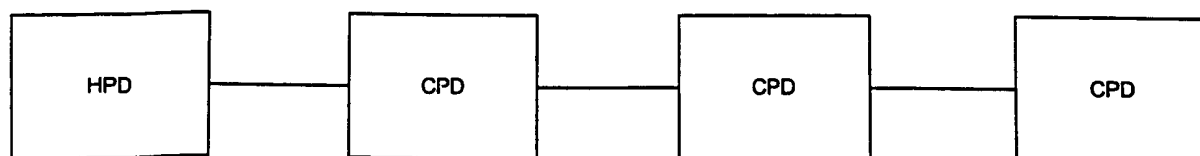

FIG. 19