

(19) World Intellectual Property  
Organization  
International Bureau



(43) International Publication Date  
25 November 2004 (25.11.2004)

PCT

(10) International Publication Number  
**WO 2004/100772 A2**

- (51) International Patent Classification<sup>7</sup>: **A61B**
- (21) International Application Number:  
PCT/US2004/014929
- (22) International Filing Date: 12 May 2004 (12.05.2004)
- (25) Filing Language: English
- (26) Publication Language: English
- (30) Priority Data:  
60/470,067 12 May 2003 (12.05.2003) US
- (71) Applicant (for all designated States except US): **UNIVERSITY OF FLORIDA** [US/US]; 223 Grinter Hall, Gainesville, FL 32611-5500 (US).
- (72) Inventors; and
- (75) Inventors/Applicants (for US only): **SANTRA, Swadeshmukul** [IN/US]; 326 University Village South, Apt. #3, Gainesville, FL 32603 (US). **MERICLE, Robert, A.** [US/US]; 4527 NW 36th Drive, Gainesville, FL 32605 (US). **BATICH, Christopher, D.** [US/US]; 3733 N.W. 40th Street, Gainesville, FL 32606-6199 (US). **STANLEY, Jessie, T.** [US/US]; 1360 N.E. State Road 47, Trenton, FL 32693 (US). **ESKIOGLU, Eric** [US/US]; 10000 SW 52nd Avenue, Apt. #158, Gainesville, FL 32608 (US).
- (74) Agents: **LADWIG, Glenn, P.** et al.; Saliwanchik, Lloyd & Saliwanchik, A Professional Association, PO Box 142950, Gainesville, FL 32614-2950 (US).
- (81) Designated States (unless otherwise indicated, for every kind of national protection available): AE, AG, AL, AM, AT, AU, AZ, BA, BB, BG, BR, BW, BY, BZ, CA, CH, CN, CO, CR, CU, CZ, DE, DK, DM, DZ, EC, EE, EG, ES, FI, GB, GD, GE, GH, GM, HR, HU, ID, IL, IN, IS, JP, KE, KG, KP, KR, KZ, LC, LK, LR, LS, LT, LU, LV, MA, MD, MG, MK, MN, MW, MX, MZ, NA, NI, NO, NZ, OM, PG, PH, PL, PT, RO, RU, SC, SD, SE, SG, SK, SL, SY, TJ, TM, TN, TR, TT, TZ, UA, UG, US, UZ, VC, VN, YU, ZA, ZM, ZW.
- (84) Designated States (unless otherwise indicated, for every kind of regional protection available): ARIPO (BW, GH, GM, KE, LS, MW, MZ, NA, SD, SL, SZ, TZ, UG, ZM, ZW), Eurasian (AM, AZ, BY, KG, KZ, MD, RU, TJ, TM), European (AT, BE, BG, CH, CY, CZ, DE, DK, EE, ES, FI, FR, GB, GR, HU, IE, IT, LU, MC, NL, PL, PT, RO, SE, SI, SK, TR), OAPI (BF, BJ, CF, CG, CI, CM, GA, GN, GQ, GW, ML, MR, NE, SN, TD, TG).
- Published:**  
— without international search report and to be republished upon receipt of that report
- For two-letter codes and other abbreviations, refer to the "Guidance Notes on Codes and Abbreviations" appearing at the beginning of each regular issue of the PCT Gazette.*

(54) Title: DEVICES AND METHODS FOR DISRUPTION AND REMOVAL OF LUNINAL OCCLUSIONS

(57) Abstract: The subject invention pertains to an elastic sheath, device, and methods for disrupting and/or removing occlusive material from lumens, particularly biological lumens, such as the vasculature, ureter, urethra, fallopian tubes, bile duct, intestines, and the like. The subject invention provides for effective disruption and removal of occlusive material, such as a thrombus, from the body lumen with minimal risk of injury to the lumen wall. Advantageously, the invention can be used to achieve a high degree of removal while minimizing the amount of occlusive material that is released into the body lumen. The subject invention further pertains to methods for disrupting and removing occlusive material from a biological lumen. In another aspect, the present invention concerns a device useful as an in vitro model of luminal occlusion and methods for using the device to test the efficacy of devices and methods for treating luminal occlusions.

WO 2004/100772 A2

DESCRIPTIONDEVICES AND METHODS FOR DISRUPTION AND  
REMOVAL OF LUMINAL OCCLUSIONS

5

Cross-Reference to Related Application

The present application claims the benefit of U.S. Provisional Application Serial No. 60/470,067, filed May 12, 2003, which is hereby incorporated by reference herein in its entirety, including any figures, tables, nucleic acid sequences, amino acid sequences,  
10 or drawings.

Background of the Invention

The blockage of human arteries can lead to a variety of serious medical complications. Arterial blockages reduce blood flow through the affected artery and may  
15 result in damage to the tissue that is relying upon the blood's supply of oxygen (ischemia). For example, if the blockage is in an artery that supplies blood to the heart itself, a heart attack may result.

Thrombosis and atherosclerosis are common ailments that result from the deposition of thrombus on the walls of blood vessels. When such deposits harden, they  
20 are commonly referred to as plaque. These plaque deposits occur commonly in blood vessels that feed the brain, heart, and limbs of the human body. Stasis, incompetent valves, and trauma in the venous circulation are common causes of thrombosis, which can often manifest as a deep vein thrombosis in the peripheral vasculature. When such deposits build-up in localized regions of the blood vessel, they can restrict blood flow and  
25 cause a serious health risk.

In addition to forming in the natural vasculature, thrombosis is a serious problem in "artificial" blood vessels, particularly in peripheral femoral-popliteal and coronary bypass grafts and dialysis access grafts and fistulas. The creation of such artificial blood vessels requires anastomotic attachment at one or more locations in the vasculature. Such  
30 sites are particularly susceptible to thrombus formation due to narrowing caused by intimal hyperplasia, and thrombus formation at these sites is a frequent cause of failure of the implanted graft or fistula. The arterio-venous grafts and fistulas that are used for

dialysis access are significantly compromised by thrombosis at the sites of anastomotic attachment and elsewhere. Thrombosis often occurs to such an extent that the graft needs to be replaced within a few years or even a few months.

A variety of methods have been developed for treating thrombosis and  
5 atherosclerosis in the coronary and peripheral vasculature as well as in implanted grafts and fistulas. Such techniques include pharmacologic thrombolytic therapy, given either intravenously or intra-arterially (Hacke W. *et al.*, *JAMA*, 274:1017-1025, 1995; del Zoppo G.J. *et al.*, *Stroke*, 29:4-11, 1998), surgical procedures, such as coronary artery bypass grafting, and minimally invasive procedures, such as angioplasty atherectomy,  
10 transmyocardial and revascularization. In particular, a variety of techniques generally referred to as “thrombectomy” have been developed. Thrombectomy generally refers to procedures for the removal of relatively soft thrombus and clot from vasculature. Removal is usually achieved by mechanically disrupting the clot, and can optionally include the administration of thrombolytic agents. The disrupted thrombus or clot is then  
15 withdrawn through a catheter, typically with a vacuum or mechanical transport device.

Thrombectomy generally differs from angioplasty and atherectomy in the type of occlusive material that is being treated and in the level of care taken to avoid damage to the blood vessel wall. The material removed in most thrombectomy procedures is relatively soft, such as the clot formed in deep vein thrombosis, and is usually not  
20 hardened plaque of the type treated by angioplasty in the coronary vasculature. Moreover, it is usually an objective of thrombectomy procedures to have minimum or no deleterious interaction with the blood vessel wall. Ideally, the clot will be disrupted and pulled away from the blood vessel wall with no harmful effect on the wall itself.

While successful thrombectomy procedures have been achieved, most have  
25 required compromise between the competing objectives of removing the thrombosis and minimizing injury to the blood vessel wall. While more aggressive thrombectomy procedures employ rotating blades that can be very effective at thrombus removal, they present a significant risk of injury to the blood vessel wall. Alternatively, those procedures that rely primarily on vacuum extraction together with minimum disruption of  
30 the thrombus, often fail to achieve sufficient thrombus removal.

U.S. Patent No. 5,904,698 describes a catheter having an expandable mesh with a blade or electrode for shearing obstructive material, which penetrates the mesh when the

mesh is expanded in a blood vessel. Other catheters having expandable meshes, cages, and/or shearing elements are described in U.S. Patent Nos. 5,972,019; 5,954,737; 5,795,322; 5,766,191; 5,556,408; 5,501,408; 5,330,484; 5,116,352; and 5,410,093; and WO 96/01591. Catheters with helical blades and/or Archimedes screws for disrupting and/or transporting clot and thrombus are described in U.S. Patent Nos. 5,947,985; 5,695,501; 5,681,335; 5,569,277; 5,569,275; 5,334,211; and 5,226,909. Other catheters of interest for performing thrombectomy and other procedures are described in U.S. Patent Nos. 5,928,186; 5,695,507; 5,423,799; 5,419,774; 4,762,130; 4,646,736; and 4,621,636. Techniques for performing thrombectomy are described in Sharafudin *et al.* (JVIR 8:911-921, 1997) and Schmitz-Rode *et al.* (Radiology 180:135-137, 1991).

One of the problems with many of these devices, however, is that particulate matter (*e.g.*, thrombus, atheroma, or other embolic or occlusive material) may be released from the wall of the vessel during the procedure. If such particulate matter travels downstream, it may become lodged or otherwise harm the patient. For example, ischemic stroke may occur when such emboli are released in the carotid or cerebral arteries and travel to the patient's brain. To prevent or minimize damage from emboli, vascular filters have been suggested that are typically disposed on a device such as a catheter, guidewire, or sheath. These devices may be introduced within a blood vessel downstream of a location being treated, and the filter on the device deployed across the vessel to capture embolic material released during the procedure. Upon completion of the procedure, the filter may be collapsed, trapping emboli therein, and then the device may be removed from the patient. Catheters having expandable filters at their distal ends are described in U.S. Patent No. 4,928,858 and PCT publications WO 99/44542 and WO 99/44510.

The United States Food and Drug Administration (FDA) has approved a total of eight mechanical thrombectomy devices (MTDs) for use in thrombosed hemodialysis grafts (Kasirajan K. *et al.*, *J. Vasc. Interv. Radiol.*, 2001, 12:405-411). Generally, the approved MTDs can be classified into two categories: (i) mechanical lysis only (non-aspirating) devices and (ii) mechanical and aspirating devices. The AMPLATZ thrombectomy device (CLOT BUSTER; MICROVENA, White Bear Lake, MN), ARROW-TREROTOLA PTD (ARROW INTERNATIONAL, Reading, PA), and CASTANEDA OVER-THE-WIRE BRUSH (MICRO THERAPEUTICS, Aliso Viego, CA) are categorized mechanical non-aspirating devices and ANGIOJET (POSSIS

MEDICAL; Minneapolis MN), GELBFISH-ENDOVAC (BOSTON SCIENTIFIC/MEDI-TECH, Brooklyn, NY), HYDROLYSER (CORDIS, Miami, FL), OASIS (BOSTON SCIENTIFIC/MEDI-TECH, Watertown, MA) are categorized under mechanical aspirating devices. The ANGIOJET LF140 (POSSIS MEDICAL, 5 Minneapolis, MN) is the only FDA approved device for use in peripheral arterial occlusive disease. These devices are currently being used or undergoing clinical evaluation for the treatment of acute and chronic limb-threatening ischemia.

Stroke is characterized by a sudden loss of blood supply to the brain, which results in loss of neurological function. Stroke is the third leading cause of death in the United States (150,000 cases per year) and the leading cause of adult disability (“2002 Heart and 10 Stroke Statistical Update”, American Heart Association, Dallas, Texas, 2001). Approximately 700,000 strokes occur annually in the U.S., accounting for costs of over \$26 billion/year for treatment and rehabilitation. Stroke is currently classified into two categories: hemorrhagic and ischemic. Ischemic stroke is the most common type and 15 accounts for 85% of all stroke cases. Ischemic stroke (*i.e.*, thromboembolic stroke) occurs when arteries supplying blood to the brain are occluded by thrombus or other embolic material (*e.g.*, calcifications, cholesterol, plaque, *etc.*).

Current treatment modalities include pharmacologic thrombolytic therapy; however, all thrombolytic drugs are not indicated for all stroke victims and are not 20 effective for all thromboembolic occlusions. The treatment of ischemic stroke patients with tissue plasminogen activator (tPA) is currently the only FDA approved treatment in the United States. However, tPA has been shown to benefit patients only if administered within a 3 hour time window after the onset of neurological symptoms. Therefore, a poor success rate in treatment of stroke is observed. Moreover, the use of tPA is associated 25 with a high risk of hemorrhage and cannot be given to all patients. Endovascular mechanical thrombolytic devices could be used to treat ischemic stroke patients less invasively and more effectively. Unfortunately, there currently exists no FDA approved device for ischemic stroke treatment. Mechanical thrombectomy devices may increase the risk of arterial perforation, dissection, or endothelial injury, which can result in 30 intracranial hemorrhage and worsening of neurological deficits, for example. Therefore, making such devices that will eliminate or even reduce these risks is an extremely challenging task. For example, a device adapted to treat ischemic stroke should be

miniaturized to fit inside intracranial arteries, which are relatively small (1 mm to 3.5 mm in diameter). Intracranial arteries are fragile and tortuous; therefore, the device should also be highly flexible and maneuverable. The use of such devices, along with tPA, may benefit patients by providing a quick recovery from ischemic stroke.

5 Preliminary studies on the safety, efficacy, and device limitations have spurred an interest in percutaneous techniques for thrombus debulking as stand-alone therapy or as an adjunct to pharmacologic thrombolysis. The devices have various mechanisms or combinations of mechanisms to optimize thrombus removal. Efficacy of thrombus removal is balanced by the propensity for vessel wall damage and distal embolization,  
10 especially for vessel wall-contact devices.

Therefore, there is a need for a device that is simple in design and is highly maneuverable to permit navigation through various lumen systems of the body, such as the intracranial, urinary, biliary, bronchial, and coronary systems, thereby facilitating effective disruption and removal of occlusive material while minimizing the risk of injury  
15 to the lumen wall.

#### Brief Summary of the Invention

The subject invention concerns a device and methods for disrupting and/or removing occlusive material from lumens, such as biological lumens within the body.  
20 Although the subject invention is particularly useful for the disruption and/or removal of thrombus from the vasculature, it is also applicable in other lumens of the body, such as the ureter, urethra, fallopian tubes, bile duct, intestines, and the like. The subject invention provides for effective disruption and/or removal of the occlusive material from the body lumen with minimal risk of injury to the lumen wall. Advantageously, the  
25 invention can be used to achieve a high degree of removal while minimizing the amount of occlusive material that is released into the body lumen. This is particularly desirable in treatment of the vasculature, where the release of emboli can be a serious risk to the patient. As described in detail below, the present invention employs a cutting means for disrupting the thrombus, clot, embolic agent, or other occlusive material.

30 The present invention relates to an elastic sheath used for constructing occlusion disruption and/or removal devices of the invention (also referred to herein as a “thrombectomy device” or “thrombolysis device”). The present invention further relates

to a device for occlusion removal and/or disruption comprising a rod, an elastic sheath that ensheaths a segment of the rod, wherein the sheath has a plurality of slits, and means for expanding the elastic sheath, wherein the elastic sheath is displaced from the segment of the rod when the expansion means is activated, and wherein the rod, the expansion means, and the elastic sheath cooperate structurally and/or functionally to form a compartment when the expansion means is activated. Preferably, the expansion means is an expandable balloon and the elastic sheath covers at least a portion of the expandable balloon and at least a segment of the rod adjacent to the expandable balloon.

The elastic sheath has a plurality of slits, with each slit separated from the adjacent slit by a band of elastic material. When the expansion means is activated, the slits expand and a compartment (also interchangeably referred to herein as the "cage") is formed through the cooperation of the rod, the elastic sheath, and the expansion means, together. When the expansion means is an expandable balloon, the balloon can be expanded by applying pressure from within the balloon, such as air or saline pressure, for example. The device can be at least partially composed of an imageable material such that the position of the device within biological tissue, such as a biological lumen, can be readily determined using the appropriate sensing equipment. Therefore, it is possible to accurately guide the device to a particular lumen within biological tissue, and to guide the device to an occluded area within the lumen for subsequent disruption and/or removal of the occlusive material.

In another aspect, the subject invention pertains to a method for disrupting and/or removing occlusive material from a biological lumen by inserting the device of the invention into the lumen, placing the device at a point adjacent to the occlusion, activating the expansion means, and operating the device in a back-and-forth motion such that the occlusion is mechanically disrupted by abrasive contact with the bands of the elastic sheath, and occlusive debris passes through the expanded slits, and is thereby captured within the cage of the elastic sheath. Optionally, the expansion means can be deactivated in order to narrow or close the slits (collapsing the cage), to more securely contain the occlusive debris between the bands of the elastic sheath and the rod. In embodiments where the expansion means is an expandable balloon, the balloon can be partially or entirely deflated in order to narrow or close the slits and collapse the cage around the rod.

In another aspect, the present invention concerns an *in vitro* model of luminal occlusion and methods for using the *in vitro* model to test the efficacy of devices and methods for treating luminal occlusions.

5

#### Brief Description of the Drawings

**Figure 1A** shows a side view of an elastic sheath constructed in accordance with the present invention, with the placement site of the balloon within the distal end of the elastic sheath. When this embodiment of the elastic sheath is utilized, one conical cage structure can be formed when the underlying balloon is activated at the balloon site shown.

10

**Figure 1B** shows a side view of an elastic sheath constructed in accordance with the present invention, with the placement site of the balloon within the central portion of the elastic tube. When this embodiment of the elastic sheath is utilized, two conical cage structures can be formed when the underlying balloon is expanded at the balloon site shown.

15

**Figures 2A-2C** show side views of a rod constructed in accordance with the present invention, with a balloon disposed along the length of the rod and constraining material wrapped around opposing segments of the balloon and adjacent segments of the rod, leaving a segment of the balloon unwrapped and, hence, capable of expansion. In Figure 2A, the unconstrained portion of the balloon is disposed toward the distal end of the rod. In Figure 2B, the unconstrained segment of the balloon is disposed toward the central portion of the rod. In Figure 2C, two unconstrained segments of the balloon are disposed toward the central portion of the rod, adjacent to one another.

20

**Figures 3A-3C** show side views of the rods shown in Figures 2A-2C, respectively, with the balloon expanded.

25

**Figures 4A-4C** show side views of devices of the subject invention in an expanded configuration. Figure 4A shows a device with one balloon, in an expanded configuration, disposed toward the distal end of the rod. Figure 4B shows a device with one balloon, in an expanded configuration, disposed toward the central portion of the rod. Figure 4C shows two balloons, in expanded configurations, disposed toward the central portion of the rod.

30

**Figure 5** shows a side view of one embodiment of the device of the invention, in an expanded configuration, with lateral bands cross-linking the longitudinal bands, to produce a mesh.

**Figure 6** shows a plot (calibration curve) of balloon diameter versus saline pressure. A control experiment with a bare balloon was performed and compared with the device. As expected, higher pressure was required to inflate the modified balloon in the device.

**Figure 7A and 7B** show an *in vitro* human middle carotid artery (MCA) model of the present invention, with A, B, C, D, and E representing different locations of the MCA. **Figure 7A** shows a polypropylene tube of 2.5 mm inner diameter (ID). **Figure 7B** shows a clot holder that is a detachable silicone pouch with two openings. The clot holder is attached to the polypropylene tube through plastic fittings.

**Figure 8** shows angiography of a right kidney and renal artery of a rabbit.

**Figure 9** shows angiography of the kidney shown in **Figure 8**, with successful thromboembolism evident.

**Figure 10** shows photographs of sliced 5mm sections of kidney.

**Figure 11** shows a side view photograph of a device constructed in accordance with the present invention.

**Figure 12** shows a side view photograph of another embodiment of the device constructed in accordance with the present invention, with lateral bands cross-linking the longitudinal bands.

#### Detailed Disclosure of the Invention

The subject invention concerns a device and methods for disrupting and/or removing occlusive material from lumens, such as a blood vessel, ureter, urethra, fallopian tube, bile duct, intestine, and the like. In addition to biological conduits, the device and methods of the present invention can be utilized to disrupt and/or remove occlusive materials from artificial conduits, such as those constructed for insertion into the body (*e.g.*, arterial or venous catheters). Where reference is made herein to the “thrombectomy device” of the subject invention, it should be understood that the device can be used to disrupt and/or remove occlusive material from any lumen, biological or artificial.

The thrombectomy device 10 of the present invention has a rod 24, an elastic sheath 40 that ensheaths at least one segment of the rod 24, and means for radially expanding the elastic sheath 40 around the segment of the rod 24. Preferably, the expansion means is at least one expandable balloon 30. In this embodiment, the thrombectomy device 10 of the present invention comprises the rod 24, at least one expandable balloon 30 disposed along the length of the rod 24, the elastic sheath 40 that covers at least a portion of the expandable balloon 30 and ensheaths at least one segment of the rod 24 adjacent to the balloon 30. Preferably, the rod 24, balloon 30, and elastic sheath 40, are co-axial.

10 Preferably, the means for expanding the elastic sheath 40 radially about the rod 24 is an expandable balloon 30. However, other means for applying sustained radial pressure to the inner surface of the elastic sheath 40, thereby expanding the elastic sheath 40 radially about the rod 24, can be utilized. For example, expansion means can include radially outwardly biased struts. In a deactivated state, the biased struts can be retained  
15 within or outside the rod 24. Upon activation, the struts are moved radially outwardly against the inner surface of the elastic sheath 40, thereby expanding the elastic sheath 40 and deploying the cage 50 (see, for example, U.S. Patent No. 5,911,734, Tsugita *et al.*, which describes a filter and strut structure). In a further embodiment, a compressive spring may be employed which pulls fore and aft ends of expandable struts together,  
20 thereby expanding the elastic sheath 40. In other words, the elastic sheath 40 is spring activated. Alternatively, the elastic sheath 40 can be expanded by a radially expandable frame structure comprising frame struts (see, for example, U.S. Patent No. 6,277,139, Levinson *et al.*, which describes a frame structure attached to perforated filter material).

The elastic sheath 40 has a plurality of slits 20, with each slit 20 separated from  
25 the adjacent slit 20 by a band 21 (or string) of elastic material. The slits 20 can be on one side of the expansion means, proximal or distal to the expansion means, or on both sides of the expansion means, proximal and distal to the expansion means. When the expansion means is activated to radially expand the elastic sheath 40 about the rod 24, a portion of the elastic sheath 40 will be displaced from a segment of the rod 24 that it  
30 previously ensheathed, the slits 20 expand, forming a compartment 50 (also interchangeably referred to herein as the cage 50 or cage structure 50) around the rod 24. Thus, in embodiments where an expandable balloon 30 is the expansion means, when the

balloon 30 is radially expanded about the rod 24 via internal pressure, such as air pressure or saline pressure, portions of the elastic sheath 40 that are adjacent to the balloon 30 are displaced from the rod 24, and the slits 20 expand, forming a roughly cone-shaped compartment 50 around the rod 24.

5 As used herein to describe the cage 50 of the subject invention, the terms “cone-shaped”, “conical”, and “frustoconical” are intended to include shapes that linearly, parabolically, or hyperbolically taper from the expansion means (such as the balloon 30) down the length of the rod 24. Any expansion means that radially expands the elastic sheath 40 to cooperate with the rod 24 in forming the cage 50 is sufficient. The conical  
10 body of the cage 50 extends (at its broadest point) expansion means to a proximal or distal point (its narrowest point) on the rod 24, as shown in Figures 4A-4C and Figure 5. Therefore, one end of the cage 50 is enlarged in diameter when the expansion means is activated and the elastic sheath 40 is displaced radially (outwardly from the rod 24), and the other end of the cage 50 tapers to the rod 24, away from the expansion means. In this  
15 way, in those embodiments wherein the expansion means is one or more expandable balloons 30, the cage 50 of the thrombectomy device 10 is “balloon-activated”. When the expansion means is not activated, the elastic sheath 40 (and, hence, the longitudinal bands 21) is in a position of repose (collapsed) in which it is preferably substantially flush with the rod 24. The conical cage 50 can be a unilateral cage, forming on one side of the  
20 expansion means, or a bilateral cage, forming on both sides of the expansion means. If the expansion means is a continuously solid structure, such as an expandable balloon 30, the bilateral cages will be separated by the expansion means. However, the expansion means can be a discontinuously solid structure, having voids through which the cages would be in communication.

25 The rod 24 of the device 10 is preferably highly flexible to facilitate navigation through tortuous biological lumens. The rod 24 can be hollow or solid, and can be composed of one or more of a variety of materials, such as melt-processible and/or non-melt-processible fluoropolymers (*e.g.*, perfluoroalkoxy (PFA); fluorinated ethylene propylene (FEP); poly(tetrafluoroethylene) (PTFE); tetrafluoroethylene (MFA); ethylene  
30 tetrafluoroethylene (ETFE); poly(vinylidene fluoride) (PVDF); ethylene chlorotrifluoroethylene (ECTFE); and poly(tetrafluoroethylene-co-perpropylvinylether) (PTFE/PPVE)); polyurethane; polyethylene; nylon; PEBAX, polyvinylchloride (PVC);

thermoplastic elastomers; polyesters; and radio-opaque and non-radio-opaque resin blends. If the rod **24** is composed of one or more polymers, the rod **24** can optionally include one or more fillers, such as barium sulfate ( $\text{BaSO}_4$ ), bismuth trioxide ( $\text{Bi}_2\text{O}_3$ ), bismuth subcarbonate ( $\text{Bi}_2\text{CO}_3$ ), and tungsten (W). Optionally, the rod **24** can include  
5 braided wire for enhanced torque capabilities, as long as the rod is sufficiently flexible and kink-resistant for the particular application. Braid wire density, which is described as picks per inch (PPI), *i.e.*, the number of wire crossovers per inch of rod, can be optimized by those skilled in the art. The rod **24** can have any of a variety of shapes in cross-section. Preferably, the rod **24** has a substantially circular cross-section. The length and  
10 diameter of the rod **24** will depend on the diameter of the lumen and the target site. For example, the length of the rod **24** can be within the range of about 50 centimeters to about 300 centimeters for many applications, and from about 2.5 F (french) to about 10 F in diameter. Preferably, the length of the rod **24** is about 150 centimeters and the diameter of the rod **24** is about 0.25 millimeters.

15 The elastic sheath **40** has the general shape of a tube, with a first end **12** with an opening **16** and a second end **14** with an opening **18**. When the device **10** is assembled, the rod **24** runs through the openings **16**, **18** of the elastic sheath **40**.

Preferably, the elastic sheath **40** is produced from an extremely flexible, tear-resistant, biocompatible polymer tube, which can be composed of any of a variety of  
20 commercially available thermoplastic elastomers. For example, in order to produce the elastic sheath **40**, slits **20** can be made in polymer tubes composed of any of a variety of materials, such as silicone, polyurethane, silicone-polyurethane copolymer, styrene-ethylene-butylene-styrene (copolymer), and other suitable elastomeric materials. The elastic sheath **40** should be sufficiently flexible and resilient such that when a radial force  
25 is applied outward from within the sheath **40** (*e.g.*, by the expanding balloon **30**), the elastic sheath **40** will expand at the point the force is applied, but will have sufficient memory to revert to its regular tubular shape when the force is removed.

The elastic sheath **40** has a plurality of slits **20**. The slits **20** can be uniformly spaced from one another or non-uniformly spaced from one another. Preferably, the slits  
30 **20** are longitudinally arranged around at least a portion of the circumference of the elastic sheath **40**, or around entire circumference of the elastic sheath **40**. However, the slits **20** can be arranged non-longitudinally on the elastic sheath **40**. For example, the slits **20** can

be arranged at a diagonal relative to the length of the sheath **40**. The slits **20** are preferably substantially parallel to one another. In one embodiment, the slits **20** are arranged transverse to the length of the sheath **40**. In another embodiment, the slits **20** are arranged non-transverse to the length of the sheath **40**.

5           In one embodiment, the elastic sheath **40** has within the range of 2 to 12 slits **20** proximal to the expansion means. In another embodiment, the elastic sheath **40** has within the range of 2 to 12 slits **20** distal to the expansion means. In another embodiment, the elastic sheath **40** has within the range of 2 to 12 slits **20** both proximal and distal to the expansion means.

10           The elastic sheath **40** preferably has a length within the range of about 5 millimeters and about 5 centimeters, and a diameter within the range of about 1 millimeter and about 1 centimeter. Preferably, the elastic sheath **40** has a thickness within the range of about 0.05 millimeters and about 2 millimeters.

          Figure 1A shows a side view of an elastic sheath **40** constructed in accordance  
15 with the present invention, with the placement site **22** of the balloon **30** within the distal end of the elastic sheath **40**. When this embodiment of the elastic sheath **40** is utilized, one conical cage structure **50** can be formed when the underlying balloon **30** is activated at the balloon site **22** shown. In Figure 1A, the longitudinal slits **20** extend from an area of the elastic sheath **40** in close proximity to the balloon **30** and the first end **12** of the  
20 elastic sheath **40**, to the second end **14** of the elastic sheath **40**, permitting formation of the conical cage **50** that extends from the balloon **30** to the point where the longitudinal slits **20** terminate. Figure 1B shows a side view of an elastic sheath **40** with the placement site **22** of the balloon **30** within the central portion of the elastic sheath **40**. When this  
25 embodiment of the elastic sheath **40** is utilized, two conical cage structures **50** can be formed (proximal and distal to the balloon **30**) when the underlying balloon **30** is expanded at the balloon site **22** shown.

          Figures 2A-2C show side views of a rod **24** constructed in accordance with the present invention, with a balloon **30** disposed along the length of the rod **24** and  
30 constraining material **28** wrapped around opposing sides of the balloon **30** and adjacent segments of the rod **24**, leaving the unconstrained segment of the balloon **30** capable of expansion. In Figure 2A, the unconstrained segment of the balloon **30** is disposed toward the distal end **26** of the rod **24** and toward the distal end of the elastic sheath **40**. In

Figure 2B, the unconstrained segment of the balloon 30 is disposed more toward the central portion of the rod 24 (as compared to Figure 2A) and approximately in the center of the elastic sheath 40. In Figure 2C, two unconstrained segments of the balloon 30 are disposed toward the central portion of the rod 24, adjacent to one another, and approximately in the center of the elastic sheath 40. In an alternative embodiment, instead of leaving two or more segments of a single balloon unconstrained, two or more separate balloons 30 can be utilized.

Figures 3A-3C show side views of the rods shown in Figures 2A-2C, respectively, with the balloons 30 expanded. Figures 4A-4C show three embodiments of the device 10 in an expanded configuration (*i.e.*, with the cage 50 deployed). As shown in Figure 4A, the elastic sheath 40 can be placed on the rod 24 such that the expandable balloon 30 is off center relative to the length of the elastic sheath 40. In this way, the size of the expanded cage 50 can be varied. Further, as shown in Figure 4B, the elastic sheath 40 can be placed on the rod 24 such that the expandable balloon 30 is approximately in the center of the elastic sheath 40, which provides two cages 50 when then the device 10 is in an expanded configuration (the balloon 30 is expanded). Figure 4C demonstrates that the device 10 may comprise a balloon 30 with two or more unconstrained segments (also shown in Figure 2C, unexpanded and without the elastic sheath 40; and in Figure 3C, expanded and without the elastic sheath 40). Alternatively, instead of leaving two or more segments of a single balloon unconstrained, two or more individual balloons 30 can be utilized.

Figure 5 shows a side view of one embodiment of the device 10 of the invention, in an expanded configuration, with lateral bands 34 cross-linking the longitudinal bands 21 such that the expanded cage 50 resembles a mesh. The lateral bands 34 can bridge longitudinal bands 21 at any of a variety of acute, obtuse, or right angles relative to the longitudinal bands 21 which they interconnect. When the device 10 is operated, the lateral bands 34 function to shear the occlusive material and enhance the ability of the cage 50 to retain disrupted occlusive debris. The lateral bands 34 can be formed integrally within the elastic sleeve 40, in a similar fashion as the longitudinal bands 21. Alternatively, the lateral bands 34 can be subsequently added and secured to the longitudinal bands 21.

Preferably, the expandable balloon **30** is spherical or substantially spherical such that, when the balloon **30** is expanded, a “cage” is formed. However, the balloon **30** can be any shape which, when expanded, also stretches and expands the longitudinal slits **20** and longitudinal bands **21**, permitting sufficient disruption of occlusive material and, preferably, capture by the cage **50**. For example, the expandable balloon **30** can be ring-shaped, permitting blood flow through the hole of the ring. Preferably, the balloon **30** is disposed concentrically around a portion of the rod **24**, as shown in Figures 11 and 12, or at its distal end **26**. When the device **10** is in an expanded configuration, the balloon **30**, cage **50**, and the rod **24** define a holding compartment to collect and hold occlusive debris material. The balloon **30** can be arranged on the rod **24** in any of a variety of ways permitting expansion of the balloon **30** and formation of the cage **50** defining the holding compartment, including many balloon-catheter arrangements known in the art (*e.g.*, FOGARTY embolectomy catheter; SENTRY balloon catheter; EQUINOX occlusion balloon system; U.S. Patent Nos. 3,435,826; 5,824,037; 4,762,130; 5,250,029; 4,403,612; 3,467,101; 5,232,445; 4,919,651; 4,637,396). The balloon **30** can be mounted longitudinally or transversally on the rod **24**, for example. Appropriate means for expanding the balloon **30**, such as by applying internal pressure to the balloon **30**, can likewise be employed. For example, the rod **24** can include one or more openings along its length that are in fluid communication with the interior of the balloon **30**, permitting passage of fluid (*e.g.*, gas or liquid) between the interior of the hollow rod **24** and the interior of the balloon **30**, as described in U.S. Patent No. 3,435,826. The rod **24** of the device **10** can include concentric or non-concentric interior lumens or an external tube connecting the balloon **30** to an external source of pressurized fluid. The expandable balloon **30** can be composed of any of a variety of materials. Preferably, the balloon **30** is a biocompatible elastic material, such as synthetic or natural rubber latex, silicone, polyurethane, polyisoprene styrene-ethylene-butylene-styrene block copolymer (SEBS), or other suitable elastomeric material.

At least a portion of the balloon **30** can be radially constrained, leaving at least one portion of the balloon **30** radially unconstrained. In this way, when pressure is applied to the constrained balloon **30**, the unconstrained portion or unconstrained portions of the balloon **30** expand but the constrained portion or portions do not. In one embodiment, an elongated, tube-shaped balloon **30** is utilized (such as an angioplasty

balloon), wherein the balloon **30** is radially constrained at either or both ends, leaving one or more segments of the balloon **30** unconstrained. In this way, when pressure is applied to the constrained balloon **30**, the unconstrained segment or unconstrained segments of the balloon **30** preferably expand to form a sphere or substantially spheroid shape. The radial constraint can be provided in any of a number of ways. For example, radial constraint can be provided by a constraining material **28** that surrounds and radially constrains portions of the balloon **30** (e.g., segments of the balloon **30** at either or both ends). The constraining material **28** prevents those portions of the balloon **30** that the constraining material **28** surrounds from expanding, leaving the rest of the balloon **30** (e.g., the center portion of the balloon **30**) capable of full expansion. For example, the constraining material **28** can be a fiber, such as polyurethane fiber (e.g., SPANDEX), that is wrapped around those portions of the balloon **30** to be constrained.

When the balloon **30** is expanded, the balloon **30** preferably has a diameter within the range of about 1 millimeter to about 3 centimeters, and a length within the range of about 1 millimeter to about 1 centimeter. Preferably, the thickness of the balloon **30** is within the range of about 0.01 millimeter and about 0.5 millimeter.

The thrombectomy device **10** of the present invention is particularly useful for treating vascular thrombosis and pathological conditions associated with vascular thrombosis, such as ischemic thromboembolic stroke. Because the device **10** of the subject invention can be constructed so as to be highly flexible and maneuverable, the device **10** will be suitable for operation in previously inaccessible anatomical regions, such as intracranial, urinary, biliary, bronchial, coronary, or other physiological lumen systems. Due to its elastic property, the cage **50** can be expanded and contracted multiple times to obtain optimal size and position before it is used to retrieve occlusive debris. Because of the soft, elastic property of the longitudinal bands **21** of the sheath **40**, the device **10** will cause minimal trauma to the endothelial cellular layer. Advantageously, the size of the cage can be controlled. The cage is formed only when the balloon is deployed by pressure. The higher the pressure applied to the balloon, the larger the cage's size. In addition, it will be possible to work with a variety of lumen sizes with the same device.

In another aspect, the subject invention pertains to a method for disrupting and/or removing occlusive material from a biological lumen, such as a blood vessel. The for

sake of simplicity, the method will be described wherein the expansion means is an expandable balloon 30. However, other means for expanding the elastic sheath 40 to form the cage 50 can be utilized. The method is carried out by inserting the device 10 of the invention into the lumen, placing the expandable balloon 30 and cage 50 at a target site within or adjacent to the occlusion, expanding the balloon 30, and operating the device in a back-and-forth and, optionally, twisting motion such that the occlusion is mechanically disrupted by shearing contact with the longitudinal bands 21 of the elastic sheath 40, or with the longitudinal bands 21 and lateral bands 34, depending upon the particular embodiment. Advantageously, occlusive fragments and debris material produced by expansion of the balloon 30 against the occlusion and/or shearing contact of the occlusion with the bands 21, pass through the expanded slits 20, and are thereby captured within the cage formed by the expanded elastic sheath 40. Advantageously, although the longitudinal bands 21 of the device 10 may contact the luminal wall, little or no damage to the luminal wall results. Optionally, the balloon 30 can then be partially or entirely deflated, in order to narrow or close the slits 20, thereby more securely containing the disrupted occlusive debris material between the bands 21 of the elastic sheath 40, the balloon 30, and the rod 24. The device 10 is then removed from the patient.

For example, an incision can be made and the device 10 of the subject invention can be inserted through an artery, such as the femoral artery in the patient's groin, and directed to the site of the occlusion. The device 10 can be inserted and positioned at a point in the lumen before, within, or beyond the occlusion. Either end of the device 10 can be inserted first into the lumen, so long as the longitudinal bands 21 and/or lateral bands 34 can make searing contact with the occlusion, thereby disrupting the occlusion and, optionally, providing an opportunity for the expanded cage 50 to capture particles from the disrupted occlusion.

Once the device 10 is in place, the means for expanding the balloon 30 can be activated. For example, the device 10 can be in operable communication with a pump that provides gas or fluid (*e.g.*, saline solution) to the balloon 30. The balloon 30 can be expanded to such an extent that the balloon 30 makes radial contact with the inner walls of the lumen or occlusive material deposited on the luminal walls. Optionally, the balloon 30 can be expanded to such an extent that the lumen becomes dilated, as during angioplasty procedures. Physicians of ordinary skill in the art can determine optimal

pressures to be applied to the balloon 30, optimal diameters to which the balloon 30 is to be expanded within the occluded lumen, and durations of balloon 30 expansion. The operator of the device 10 can use a back-and-forth and/or twisting motion in order to facilitate disruption and capture of the occlusive material within the cage 50. The balloon  
5 30 can then be deflated, contracting the cage 50, and the device 10 can be withdrawn from the biological lumen. Preferably, the device 10 is operated such that any occlusive debris freed by the device is maintained proximally of the balloon 30 and the distal rod end 26, thereby minimizing the risk of occlusive debris migrating to a remote site.

Optionally, the thrombolytic device 10 of the subject invention can be used in  
10 conjunction with various pharmacologic substances that breakup or dissolve the occlusion, and/or prevent the formation of future occlusions. For example, in the case of blood clots (also known as thrombi), various anticoagulant, thrombolytic (so called "clot-busting" drugs) or anti-platelet agents can be administered orally or intravenously. Examples include heparin (CALCIPARINE, HEPATHROM, LIP-HEPIN, LIQUAEMIN,  
15 PANHEPRIN), warfarin (ATHROBMIN-K, PANWARFIN), tissue plasminogen activator (tPA; ALTEPLASE; ACTIVASE), streptokinase (KABIKINASE, STREPTASE), urokinase (ABBOKINASE), anistreplase, aminocaproic acid, aprotinin, acetylsalicylic acid (aspirin), dipyridamole (PERSANTINE), abciximab (CENTOCOR), dalteparin (FRAGMIN), enoxaparin (LOVENOX), hirudin (DESIRUDIN), 4-  
20 hydroxycoumarin (COUMADIN), lepirudin (REFLUDAN), protamine sulfate, phytonadione (Vitamin K<sub>1</sub>), reteplase (RETAVASE), and ticlopidine (TICLID). Many of these agents operate by inhibiting the clotting mechanism (anticoagulants), lysing thrombi (fibrinolytic agents), and interfering with platelet adhesion and/or aggregation.

Various components of the thrombolytic device 10, such as the rod 24, the elastic  
25 sheath 40, and/or the expansion means (such as the expandable balloon 30), can be impregnated or coated with one or more biologically active agents, such as pharmacologic substances that breakup or dissolve the particular occlusion to be removed. The biologically active agents can function on contact with the device 10 or the substances can be released from the device 10 into the biological lumen in a controlled  
30 release fashion. Optionally, the biologically active agents can be released and/or become activated upon contact with blood, or otherwise be responsive to the physiological environment. For example, the biologically active agents can be temperature-sensitive

and/or pH-sensitive. As an alternative to impregnated or coated components, the biologically active agent can be delivered by other means, such as a port on the rod **24** of the device **10** that permits injection of the biologically active agent at a target site. As used herein, the term “biologically active agent” refers to any substance that is capable of promoting or causing a therapeutic effect in a patient.

Methods known in the art for insertion and operation of an angioplasty catheter can also be utilized with the device **10** of the present invention. For example, the device **10** of the present invention can be introduced into a biological lumen through an introducer (also known as an introducing catheter), which is used to access the lumen. Guide wires can also be utilized.

As indicated above, where reference is made herein to the “thrombectomy device” or “thrombolytic device” of the subject invention, it should be understood that these terms are used herein interchangeably and the device can be used to disrupt and/or remove any occlusive material from any lumen, whether the occlusive material and lumen are biological or artificial. For example, in addition to disrupting and, optionally, removing thrombus or other endogenous embolic material, such as calcifications, cholesterol, plaque, *etc.*, from a biological lumen, the device **10** of the present invention can be used to disrupt and/or remove exogenous embolic material, such as embolic agents. Embolic agents that can be disrupted and/or removed with the device **10** of the present invention include, but are not limited to, adhesive (such as polymerizing adhesive), gel, silicone rubbers, urethanes and other organic elastomers, polymerizable protein solutions, silk sutures, polyvinyl alcohol (PVA) particles, cross-linked polyvinyl alcohol foam, polyurethane foam, acrylic polymers, polyethylene foam, silicone foam, fluorinated polyolefin foam, and/or an ethylene-vinyl-alcohol copolymer commercially available under the designation ONYX by MICRO THERAPEUTICS, INC (Irving, California) (Dehdashti, A.R. *et al.*, *Neurosurg. Focus* 11(5):1-6, 2001; Halbach V.V. *et al.*, *AJR* 153:467-476, 1989; Purdy P.D. *et al.*, *J. Neurosurg.* 77:217-222, 1992; Purdy P.D. *et al.*, *Am. J. Neuroradiol.* 11:501-510, 1990).

ONYX is a liquid embolic (or embolization) agent that is a mixture of ethylene-vinyl alcohol copolymer (EVOH), dimethyl sulfoxide (DMSO), and micronized tantalum (to enable visualization under fluoroscopy) that can be used to fill aneurysms. Contact of ONYX with blood results in its solidification from the outside inward, thereby forming a

spongy polymeric cast (Jahan R. *et al.*, *Neurosurgery* 48(5):984-997, 2001; Hamada J. *et al.*, *J. Neurosurg.* 97(4):889-895, 2002; Hamada J. *et al.*, *Am. J. Neuroradiol.* 17(10):1895-1899, 1996). The ONYX embolic agent can be used for the treatment of aneurysms and arterio-venous malformations (AVMs), two conditions which can lead to hemorrhagic stroke. Once delivered inside the targeted malformation, the ONYX embolic agent quickly solidifies into a spongy polymer mass designed to seal off the defective portion of the vessel. In aneurysm and AVM applications, the ONYX filling is intended to reduce the risk of rupture and subsequent stroke. The device 10 of the present invention can be used to disrupt and/or remove excess or otherwise undesired ONYX material present within a vessel.

Depending upon the occlusive material to be removed or retrieved, disruption or breaking apart of the occlusive material may not be necessary. For example, where the device 10 of the present invention is used to retrieve embolization devices, such as those used in the field of cardiology for treating aneurysms, no disruption of the embolization device may be necessary and the embolization device may simply be captured with the cage 50 of the device 10 of the present invention and pulled out of the biological lumen. Examples of such embolization devices include, but are not limited to, PVA particles, detachable balloons, and embolization coils. Advantageously, large or small amounts of occlusive material can be removed using the device 10 of the present invention. The occlusive material can be any occlusive or potentially occlusive material that can be dislodged from the luminal wall and/or captured by the cage 50 of the device 10. The occlusive material can be of various phases, such as solid, semi-solid, or liquid.

Optionally, any component of the thrombectomy device 10 of the subject invention can be at least partially composed of an imageable material. For example, the rod 24, balloon 30, and/or elastic sheath 40, can be composed of an imageable material. As used herein, an "imageable material" includes those materials the location of which can be discerned within a given opaque, ambient medium such as biological tissue, using the appropriate sensing equipment, such as imaging equipment. The imageable material selected should have an image "signature" discernibly different from that of the surrounding medium into which the device 10 is to be introduced. Components of the device 10 can be coated or impregnated with one or more imageable materials, for example.

In one embodiment, the imageable material is an echogenic material with an acoustic impedance different from that of the surrounding medium (*i.e.*, high acoustic impedance differential), enabling the thrombectomy device **10** to be imaged using a sonic imaging device (*e.g.*, ultrasound imaging equipment). A variety of materials that are echogenic (*i.e.*, sound reflective) can be utilized, such as aluminum, hard plastic, sand, and metal particles. For example, the echogenic material can be any of those materials described in U.S. Patent No. 5,201,314 and U.S. Patent No. 6,106,473, or a combination of those materials. In another embodiment, the imageable material is a radio-opaque material (such as barium sulfate, tantalum, and/or gadolinium particles) that can be imaged with radiographic equipment (*e.g.*, an x-ray machine or computed tomography (CT) scanner). In a further embodiment, the imageable material is a substance that can be imaged using magnetic resonance imaging/spectroscopy (MRI/MRS) equipment. Other imageable materials include those materials detectable through single photon emission tomography (SPECT) or positron emission tomography (PET), for example. The component or components of the thrombectomy device **10** can be wholly or partly composed of the imageable material. As indicated above, the imageable material can be in the form of a coating or film on an underlying substrate.

Contrast media, such as dyes, can also be used in conjunction with the appropriate imaging equipment in order to discern more details within the biological lumen. For example, barium-containing and iodine-containing dyes can be administered in conjunction with x-ray or CT imaging. Gadolinium, for example, can be used in conjunction with MRI imaging.

Optionally, the device **10** of the present invention can further include a means for providing a jet or jets of fluid under pressure to the distal end **26** of the rod **24**, and/or at any point or points along the rod's length. For example, the rod **24** of the device **10** can be hollow and in operable communication with a pump that provides fluid under pressure to the distal end of the rod **24**, where it exits the rod **24** through an outlet. The fluid jet can facilitate disruption of occlusions within the biological lumen.

Optionally, the device **10** of the present invention can include a means for vacuuming occluding debris from the lumen at the distal end **26** of the rod **24**, and/or at any point or points along the rod's length. For example, the rod **24** of the device **10** can be hollow and in operable communication with a means for providing negative pressure

to the interior of the rod, such that occlusive debris is drawn into inlets along the length and/or the end of the rod **24**. Optionally, the device **10** can include both a jet means and a vacuum means, as described above. In one embodiment, the jet means and vacuum means can be alternatively operated to expel fluid from the device **10**, in order to disrupt  
5 an occlusion, and to take up the occlusive debris upon activation of the vacuum means.

In addition to natural biological conduits of the body, such as blood vessels (veins, arteries, *etc.*), ureter, urethra, fallopian tube, bile duct, intestine, and the like, the device **10** and methods of the present invention can be utilized to remove occlusive materials from other biological or artificial conduits, such as arterial or venous catheters, stents,  
10 grafts, such as peripheral femoral-popliteal, coronary bypass grafts and dialysis access grafts, and fistulas.

The occlusion-removing device **10** of the present invention can be utilized to disrupt and/or remove occlusive material from natural or artificial lumens within humans or animals, such as non-human mammals. Thus, the device **10** of the present invention  
15 can be used in a variety of veterinary applications in order to treat domesticated or non-domesticated animals. The dimensions of the various components of the device **10** can be optimized for the particular animal subject.

In another aspect, the present invention concerns a device **60** useful as an *in vitro* model of luminal occlusion, such as that shown in Figures 7A and 7B, and methods for  
20 using the device **60** to test the efficacy of devices and methods for treating luminal occlusions. The device **60** includes a flexible hollow tube **61** having a first end **62** and second end **64**. The flexible tube **61** can be composed of any material, such as silicone, which permits bending of the tube **61** into a tortuous shape, if desired. For example, the flexible tube can be composed of one or more melt-processible or non-melt-processible  
25 polymers; polyurethane; polyethylene; nylon; PEBAX, polyvinylchloride (PVC); thermoplastic elastomers; polyesters; and resin blends.

As shown in Figure 7A, one or more bends can be placed in the tube **61** in order to simulate vasculature of the brain, for example. At one or more points along the length of the tube **61**, occlusion sites can be established. In one embodiment, each occlusion site  
30 (A, B, C, D, E) has a three-way receptacle **66** (also referred to herein as a "clot holder") with ports **68** (also referred to herein as "fittings") connecting the receptacle **66** to the tube **61**. The three-way receptacle **66** contains an occlusion **70**, such as a naturally

occurring or artificial clot. The receptacle 66 can further include an access port 73 for inserting an occlusion 70. The diameter and length of the tube 61 are preferably of dimensions to accommodate a particular test device to be inserted into the first or second ends 62, 64 of the tube 61 and to mimic the particular artificial or biological lumen to be modeled. Optionally, the tube 61 can have one or more branches and sub-branches. The tube 61 can contain a fluid, such as saline or blood, to mimic a biological vessel. The test device can be inserted into either end of the tube 61 and navigated to an occlusion site to act on an occlusion 70. The performance of the test device can then be evaluated. Test criteria will depend upon the nature of the technique and/or test device and the objective to be achieved.

The terms “comprising”, “consisting of” and “consisting essentially of” are defined according to their standard meaning. The terms may be substituted for one another throughout the instant application in order to attach the specific meaning associated with each term.

As used in this specification and the appended claims, the singular forms “a”, “an”, and “the” include plural reference unless the context clearly dictates otherwise. Thus, for example, a reference to “an expandable balloon” includes more than one such balloon. A reference to “an elastic sheath” includes more than one such sheath. A reference to “a compartment” (*i.e.*, “a cage”) includes more than one such compartment. A reference to “an occlusion site” includes more than one such occlusion site, and the like.

All patents, patent applications, provisional applications, and publications referred to or cited herein, whether supra or infra, are incorporated herein by reference in their entirety to the extent they are not inconsistent with the explicit teachings of this specification.

Following are examples which illustrate procedures, including the best mode, for practicing the subject invention. These examples should not be construed as limiting. All percentages are by weight and all solvent mixture proportions are by volume unless otherwise noted.

### Example 1 – Construction of a Thrombectomy Device

A thrombectomy device of the subject invention has been made in a modular fashion. The device consists of an elastomeric polymer tube of an appropriate size and a  
5 balloon catheter.

Tubes were made from CARBOSIL 40 90A (The Polymer Technology Group, Inc., Berkeley, CA), a solution grade elastomeric, tear-resistant silicone-polyurethane thermoplastic copolymer, by the dip-coating method. Several 21 (0.80 mm outer diameter, OD) gauge injection needles (MONOJECT from Sherwood Medical, St. Louis,  
10 MO) were used as mold substrates. Each needle was 1.5 inches long and the size (OD) of the needle represents approximately the inner diameter (ID) of the resulting tube. Two times dipping of each needle in 15 wt% polymer solution in tetrahydrofuran (THF) at about a 4 mm/sec withdrawal rate and a 30 minute interval between two successive dippings formed an approximately 90  $\mu\text{m}$  thick polymer coating. Coated needles were  
15 then vacuum-dried. Coating on both ends of the needle was non-uniform. Therefore, keeping a uniform section of 30 mm long coating around the middle of the needle, the remaining coating was carefully cut by a sharp surgical razor blade (MILTEX Surgical Blades, model 4197 #11, MILTEX Instrument Company, Inc., Bethpage, NY) and then removed. At this point, the coating could be detached in the form of a uniform tube.

Without detaching the coating from the needles, a pattern was made on the coating manually by a sharp black permanent marker, as shown in Figures 1A and 1B, (SHARPIE Ultra Fine Point Permanent Marker from SANFORD Corporation, Bellwood, IL). The pattern was along the length and around the needle. A total of 5 slits  
20 were then cut along the pattern with a stainless steel surgical blade of about 10  $\mu\text{m}$  tip size. Slits 20 were 10 mm long and the spacing between two slits 20 (defining a band 21 there  
25 between) was about 550  $\mu\text{m}$ . This step was carried out under a microscope. Needles were then immersed in 60% acetone in water (V/V) for 5 minutes for swelling the polymer. The coating was then detached in the form of a uniform tube when pushed lightly off the needle. The actual modified polymer tube is shown in Figure 11.

30 A SENTRY balloon catheter was purchased from BOSTON SCIENTIFIC-TARGET, Fremont, CA. The balloon diameter and the balloon length were 3.5 mm and 10 mm when inflated. The balloon portion of the catheter was modified by constraining

more of the proximal end of the balloon than the distal end, as shown in Figure 2A, or by constraining about equal portions of the proximal end and distal end of the balloon, as shown in Figures 2B and 2C. The modified balloon portion was 2 mm long. This was done by wrapping around a stretchable, segmented polyurethane fiber (The Polymer  
5 Technology Group Inc., Berkeley, CA). Prior to wrapping, the fiber was pre-stretched to about 100% of its original length. When pressure was applied by injecting saline solution, only the unconstrained segment of the balloon **30** inflated, as shown in Figures 3A-3C.

The modified polymer tube was then swelled by immersion in 60% acetone in  
10 water (V/V) for 5 minutes. Swelling of approximately 40% of its original size occurred. The swelled tube was then slipped over the modified balloon in a desired location. The ID of the tube was smaller (about 0.2 mm) than the OD of the balloon. Once dried under the vacuum, the elastomeric tube captured the modified balloon firmly, as shown in Figures 4A-4C, with the actual device shown in Figure 11.

15 Two preliminary tests were performed on the thrombectomy device: mechanical testing and *in vitro* performance testing.

#### Example 2 – Mechanical Testing of a Modified Balloon Under Applied Saline Pressure

To determine the inflated balloon size with respect to the applied saline pressure,  
20 the device was installed on a micromanipulator. Using a digital inflation device and fluid dispensing syringe (MONARCH 25, MERIT MEDICAL SYSTEMS, Inc., South Jordan, UT) the saline pressure was applied. The micromanipulator read the inflated balloon diameter quite accurately at different saline pressures. The digital inflation device showed the applied saline pressure directly. A plot (calibration curve) of balloon diameter  
25 versus saline pressure was constructed as shown in Figure 6. A control experiment with a bare balloon was performed and compared with the device. As expected, higher pressure was required to inflate the modified balloon in the device. This type of calibration curve will be helpful for both *in vitro* and *in vivo* device operation.

30 Example 3—*In Vitro* Performance Testing of the Thrombectomy Device in Silicone Tubing

40 cm long silicone tubing (ID 2.5 mm) was selected for the preliminary *in vitro* performance testing of the device **60**. Two syringes were placed at both ends of the tube **61**. Due to the flexible nature of the tube **61**, an approximately tortuous shape could be given without kinking, as shown in Figure 7A. Rabbit blood clots were used as models for the experiment. 1 ml of blood was allowed to coagulate in a 7 ml sterile blood collection tube for a period of 1 hour. The tube **61** was then opened and the bulk clot was removed and cut in half. Each section was weighed and recorded. The silicone tube **61** was prepared by flushing it with saline solution to remove any air bubbles from the tube **61**. The blood clot was placed in a 3ml syringe and injected into the silicone tube **61**. Saline was then injected into the silicone tube **61** until the clot reached approximately 20cm from the proximal end (first end, **62**) of the tube **61**. The syringe on the distal end (second end, **64**) was kept attached to the silicone tube **61**, but the proximal syringe was replaced with a 3-way device that allowed the catheter to be inserted.

The thrombectomy device **10** was first navigated through the tube **61** and passed through the emboli. The thrombectomy device **10** was then slowly deployed up to a desired size (about 2.2 mm) and pulled back. The cage structure was able to grab the emboli and move it out of the tube **61**.

#### Example 4—Materials for Making the Elastic Sheath

This component is the most important part of the thrombectomy device because it will directly contact and manipulate the thrombus. A modified balloon catheter will assist this component to make its cage-like shape when deployed.

Tear-resistant biocompatible elastomeric polymer materials will be chosen for making tubes. Two types of commercially available solution grade (SG) thermoplastic materials will be selected: a polyurethane (TECOFLEX SG-80A, THERMEDICS Polymer Products, Woburn, MA); and a few silicone-polyurethane copolymers (CARBOSIL 40 90A, PurSil 20 80A and PurSil AL5 75A, The Polymer Technology Group Inc., Berkeley, CA). TECOFLEX SG-80A is an aliphatic polyether-based thermoplastic polyurethane (TPU). PURSIL silicone-polyether-urethane and CARBOSIL silicone-polycarbonate-urethane are thermoplastic copolymers containing silicone in the soft segment. PURSIL 20 80A is an aromatic silicone polyetherurethane whereas PURSIL AL5 75A is an aliphatic silicone polyetherurethane. Table 1 lists some of the

physical test data of these materials reported by the manufacturers. From the table it is clear that these materials cover a range of mechanical properties. The purpose of selecting all four materials under this study is to find the right material for the optimized device.

5 Table 1. Physical Test Data of Elastomeric Polymer Materials

Elastomer	Tensile Stress at 100% Elongation (psi)	Tensile Stress at 300% Elongation (psi)	Ultimate Tensile Strength (psi)	Ultimate Elongation (%)	Tear Strength, die "C" (pli)
TECOFLEX EG-80A	300	800	5800	660	N/A
PURSIL 20 80A	270	570	5300	900	390
PURSIL AL5 75A	900	1630	4900	770	115
CARBOSIL 40 90A	1310	2400	4300	530	500

The data for TECOFLEX EG-80A represent data for extrusion grade materials. The solution grade data are not available. The solution grades differ from the extrusion grades in that they contain no melt processing lubricants.

10 If required, in order to clearly visualize the tube under a fluoroscope while performing *in vivo* tests, the tube can be constructed so as to be radio-opaque. Radio-opaque grade TECOFLEX is available with 20 wt% and 40 wt% loading of barium sulfate. Other polymers could be either blended with barium sulfate or could be custom-blended from the manufacturer.

15 The dip-coating method will be used to make polymer tubes. TECOFLEX EG-80A is soluble in N, N-dimethylacetamide (DMAC), and other silicone-polyurethane copolymers are soluble in tetrahydrofuran (THF). Tubes will be made using 21 gauge needles (OD 0.8 mm). The inner diameter (ID) of the tube will be 0.8 mm or little less, if the polymer shrinks after drying. Tube thickness generally depends upon three  
 20 parameters: the polymer concentration; the total number of dippings; and the withdrawal rate. By proper adjustment of these three parameters, tubes will be made of about 100  $\mu\text{m}$  in thickness. Table 2 shows the details.

Table 2. Elastic Sheath Design

Needle size (gauge)	size	Number of slits	Pattern	Slit length (mm) (approximately)	Tube thickness ( $\mu\text{m}$ ) (approximately)	Calculated spacing between two adjacent slits ( $\mu\text{m}$ ) (approximately)
21 (0.8 mm OD)		5	A	10 (type 1A) and 15 (type 2A)	100	630
			B	6.5 (type B)		

5

Tubes will be modified in three different patterns (A, B, and C), as shown in Figures 2A-2C, respectively, to produce elastic sheaths **40** of the subject invention. Patterns A and B will produce sheaths **40** with 10 mm and 15 mm long slits **20**, respectively. In structure A, the modified balloon **30** will be located at one end of the slits **20** (towards the catheter tip); whereas, in structure B, the balloon **30** will be located in the middle along the length of the slits **20**. The operation of the device with structure A is "one way" such that, after being passed through the thrombus, the cage structure is deployed and then pulled back through the thrombus, disrupting the thrombus and capturing thrombotic debris. Unlike structure A, structures B and C have double cage structures, which means that they function to disrupt and capture thrombus both when pushed and pulled through the occluded region of the vessel. Therefore, it is expected that the double cage structure will have an advantage in grabbing more thrombus, compared to the single cage structure. As described previously, longitudinal slits **20** will be made under a microscope using sharp surgical blade of about 10 micron tip size. The total number of longitudinal slits **20** in each elastic sheath **40** will be 5.

#### Example 5—Mechanical Testing of an Elastic Sheath

All mechanical testing will be performed using an INSTRON model 4301 (INSTRON Corporation, Canton, MA). Using an appropriate load cell (e.g., tension/compression 250 gm load cell, INSTRON model: type 00), a complete stress-strain profile for both modified and unmodified tubing will be generated. By this measurement, the mechanical characteristics of all three structures, A, B and C, will be compared directly.

Flexibility and maneuverability testing are useful to predict the feasibility of navigating the device through the tortuous intracranial vasculature system in the brain. A three-point bend test will be conducted. A bend test fixture and an "S" hook for the bend test will be designed and constructed. Thin tubes will likely kink while performing the bend test. In order to overcome this problem, compliant (highly flexible) silicone rods of an appropriate size will be made and used as substrate for the tube. Once the tube is mounted over the rod, it will not kink while performing the bend test. Approximately 0.8 mm OD silicone rods will be made from two-component platinum cure SILASTIC T2 (DOW CORNING, Midland, MI) mold making rubber. Appropriately sized (*e.g.*, about 0.8 mm ID) melting point glass capillary tubes (KIMAX-51 borosilicate glass from KIMBLE-KONTES, Vineland, New Jersey) will be used as a mold substrate. Once cured inside the capillary tube, the silicone rods will be removed from the mold by dissolving the glass in hydrofluoric acid.

The measurement of the string tear strength will be important in order to prevent breaking of the strings in the cage structure during the thrombus retrieval process. We will first mount the modified tube on an appropriate rigid rod (stainless steel needle), and then both ends of the tube will be fixed to the rod by tying with non-stretchable fiber. Using an INSTRON setup, each string will be pulled with respect to the rest until it breaks. A stress versus displacement plot will be generated for the comparison of string strengths of three different structures.

#### Example 6-- *In Vitro* Performance Testing of the Thrombectomy Device in a Middle Carotid Artery (MCA) Model

SENTRY balloon catheters (150 cm long) will be purchased from BOSTON SCIENTIFIC-TARGET, Fremont, CA. The balloon diameter and the balloon length are 3.5 mm and 15 mm, respectively, when inflated. The diameter of the catheter at the balloon is 0.86 mm when un-inflated. The balloon portion of the catheter will be modified to create balloon types A and B by constraining it at both ends into a 2 mm long balloon in the middle, as shown in Figure 2A and 2B. Balloon type C (Figure 2C) will be made similarly as type A and B with the exception that, in type C, the balloon will be further split into two halves by constraining the middle portion of the balloon. This will be done by wrapping around stretchable, segmented polyurethane fiber. Prior to

wrapping, the fiber will be pre-stretched about 100% of its original length. The balloon modification steps will be carried out under a microscope. When pressure is applied by injecting saline, only the unobstructed balloon portion will inflate, as shown in Figures 3A-3C. Mechanical testing of the modified balloon catheter will involve measurement of  
5 the balloon diameter increase with respect to the saline pressure to determine the optimum inflation pressure. Mechanical testing on these modified balloons will then be performed. A plot will be constructed showing the increase of the balloon diameter with respect to the increase of the saline pressure. This plot will facilitate the determination of optimum saline pressures for a desired balloon size.

10 Both the modified balloon catheter and the modified tube will be re-inspected under a microscope before the final assembling. The modified polymer tube will then be swelled by immersing it in an appropriate solvent as described before. Swelling of approximately 30% of its original size would be sufficient to slip it over the modified  
15 balloon. The ID of the tube will purposely be made smaller than the OD of the balloon portion of the catheter. Once dried under the vacuum, the elastomeric tubing will capture the modified balloon firmly. Schematic representation of the device is shown in Figures 4A-4C. In order to secure the thrombus inside the cage structure, a "spider-web" like pattern can be made near the balloon of the device, covering about 50 % of the tube length, for example, as shown in Figure 5. Polymer solution (same as the tube material)  
20 will be directly applied in the form of a fine fiber onto the inflated device in such a way that it will connect the elastomeric strings.

The mechanical testing will be performed using an Instron setup as described earlier in the preliminary study section. The flexibility testing of the device will be performed by a three point bend test. A calibration curve will be generated showing  
25 maximum cage diameter with respect to the saline pressure. This experiment will help for *in vitro* and *in vivo* testing of the device.

A polypropylene tube (PP) of 2.50 mm ID will be used for making the model of the tortuous MCA. This type of tube may kink while bending it to give the tortuous shape. To overcome this problem, an appropriate size copper wire will be inserted inside  
30 the PP tube first to give the right shape to the tube. Translucent silicone glue (SILASTIC T2 from DOW CORNING) will be applied over the PP tube and then it will be heat treated. Once cured, silicone oil will be injected into the tube to make the tube interior

slippery. Then the structure will be straightened and the copper wire support will be removed. Once released, the tube will return to its tortuous shape. Silicone over-coating should reinforce and retain the structure. It will then be cleaned and installed as shown in Figure 7A.

5 Clots will be made directly from rabbit blood. The plastic MCA model will be marked A, B, C, D and E, as shown in Figure 7A, which will represent different locations of the MCA. The tube will then be cut at each location to attach a clot holder. The clot holder will be a detachable silicone pouch with two openings, as shown in Figure 7B. Both openings of the holder will be attached to the model through plastic fittings. This  
10 pouch will then be filled with condensed clot (the clot condensation will be done by centrifugation). Before operation of the device, the model will be bathed with saline solution. All locations, from A through E, will be tested with the device to evaluate the device performance at each location. The feedback from the *in vitro* testing will help for the further development of the device. A repeated redesigning and remanufacturing  
15 process will be carried out to optimize the device performance for three different cage patterns (A, B and C). This investigation will provide information on the best polymer material (out of four different materials) for each cage pattern.

20 Example 7—*In Vivo* Performance Testing of the Thrombectomy Device in a Rabbit Kidney Occlusion Model

A rabbit kidney occlusion model closely mimics the MCA in humans (in terms of the lumen size) will be utilized. Prior to the surgical procedure, the animal will be sedated with acetylpromazine (0.5-2.0 mg/kg SQ or IM) and 0.5 ml of blood will be drawn from the central auricular artery and allowed to coagulate in a 3 ml blood  
25 collection tube with a wire for one hour at 37°C. This autologous thrombus will be used for creation of the thromboembolic occlusion. The animal will then be weighed to determine proper injectable anesthetic doses, and placed under general anesthesia. General anesthesia will be induced with KAX (0.6ml/kg), a mixture of 10ml ketamine HCl (PHOENIX PHARMACEUTICALS, 100mg/kg), 2.0ml acepromazine maleate  
30 (PHOENIX PHARMACEUTICALS, 10mg/kg), and 1.5ml xylazine (PHOENIX PHARMACEUTICALS, 100mg/kg).

Following sufficient sedation, the animal will be intubated and attached to a ventilator providing an oxygen mixture (21% oxygen USP, 79% nitrogen). The surgical site will then be shaved, prepped and draped in a sterile fashion using 3 cycles of surgical scrub and alcohol/chlorhexidine rinse. The level of anesthesia will be monitored by heart rate, respiration rate, temperature, animal movement, pupillary size, toe pinch reflex, blinking reflex, fluid balance tearing, and salivation. Additional doses of KAX (0.3ml/kg) will be given to maintain general anesthesia. An incision will be made in the hindlimb of the rabbit to expose the femoral artery for catheterization. A slit will be cut in the artery with micro-scissors and a 4F introducer sheath will be placed into the femoral artery and secured in place with a 4.0 silk suture. A 3F angiographic catheter and a guidewire will then be advanced with fluoroscopic guidance towards the right kidney until catheterization of the renal artery is achieved (1.5-3.5 mm diameter). Digital subtraction angiography will be performed to confirm proper placement of the catheter (Figure 8).

After the previously obtained autologous thrombus has matured for 1 hour, it will be cut into 2 sections and a section will be placed into a 0.9% saline filled syringe for embolization. The thrombus segment and saline will then be injected into the lower branch of the right renal artery. Without moving the catheter, the second clot segment will be injected. Successful thromboembolism of the renal artery will be confirmed with angiography (Figure 9). The left renal artery will then be catheterized with the same technique. The same procedure as described above will be repeated in the left renal artery. All of the animals will remain under general anesthesia for 30 minutes after thrombus injection, but before initiating any treatment.

Final angiography will be performed bilaterally 4 hours after clot injection to determine recanalization status and will be graded with the TIMI (Thrombosis in Myocardial Infarction) score, which is a commonly used system for grading recanalization. The animal will be euthanized with an overdose of sodium pentobarbital. The kidneys will be surgically removed, sliced into 5 mm sections and allowed to soak in TTC stain for 30 minutes. The specimens will then be digitally photographed (Figure 10) and the infarction percent of each kidney will be calculated.

It should be understood that the examples and embodiments described herein are for illustrative purposes only and that various modifications or changes in light thereof

will be suggested to persons skilled in the art and are to be included within the spirit and purview of this application.

Claims

We claim:

1. A device for occlusion removal and/or disruption comprising:  
a rod;  
an elastic sheath that ensheaths a segment of said rod, wherein said sheath has a plurality of slits; and  
means for expanding said elastic sheath, and wherein said elastic sheath is displaced from said segment of said rod when said expansion means is activated, and wherein said rod and said elastic sheath cooperate to form a compartment when said expansion means is activated.
2. The device of claim 1, wherein said expansion means comprises an expandable balloon, wherein at least a portion of said expandable balloon is covered by said elastic sheath.
3. The device of claims 1 or 2, wherein said plurality of slits are longitudinally arranged around at least a portion of the circumference of said elastic sheath, and wherein each slit is separated from adjacent slits by a longitudinal band of elastic material.
4. The device of claim 3, wherein said longitudinal bands are cross-linked with a plurality of lateral bands that bridge said longitudinal slits, thereby forming a mesh.
5. The device of any of claims 2 through 4, wherein said expandable balloon comprises at least one radially constrained portion and at least one radially unconstrained portion.
6. The device of claim 5, wherein when pressure is applied to said expandable balloon, said at least one radially unconstrained portion expands to form at least one sphere or spheroid shape.

7. The device of claims 5 or 6, wherein said at least one radially constrained portion is constrained with a fiber that is wrapped around said at least one radially constrained portion.

8. The device of any of claims 1 through 7, wherein the compartment is substantially conical in shape.

9. The device of any of claims 1 through 8, wherein the elastic sheath comprises a flexible polymer tube.

10. The device of any of claims 1 through 9, wherein the elastic sheath comprises a thermoplastic elastomer.

11. The device of any of claims 1 through 9, wherein the elastic sheath comprises a flexible polymer selected from the group consisting of silicone, polyurethane, silicone-polyurethane copolymer, and styrene-ethylene-butylene-styrene (copolymer).

12. The device of any of claims 1 through 11, wherein said device is at least partially composed of an imageable material.

13. A method for disruption and/or removal of occlusive material from a conduit, said method comprising:

- (a) inserting the device of any of claims 1 through 12 into the conduit;
- (b) positioning the device at a target site within or adjacent to the occlusive material;
- (c) activating the expansion means, thereby displacing the elastic sheath from the rod, and wherein the rod and the elastic sheath cooperate to form a compartment when the expansion means is activated; and
- (d) capturing the occlusive material within the compartment by allowing the occlusive material to pass through the slits of the elastic sheath.

14. The method of claim 13, wherein said method further comprises:

(e) deactivating the expansion means after capturing the occlusive material within the compartment, thereby collapsing the compartment; and

(f) withdrawing the device from the conduit.

15. The method of claim 13, wherein the expansion means comprises an expandable balloon.

16. The method of claim 15, wherein said method further comprises:

(e) at least partially deflating the balloon after capturing the occlusive material within the compartment, thereby collapsing the compartment; and

(f) withdrawing the device from the conduit.

17. The method of any of claims 13 through 16, wherein the conduit is a biological conduit.

18. The method of any of claims 13 through 17, wherein the conduit is a biological conduit within a human.

19. The method of any of claims 13 through 16, wherein the conduit is a biological conduit within a non-human animal.

20. The method of any of claims 13 through 16, wherein the conduit is a biological conduit selected from the group consisting of a blood vessel, ureter, urethra, fallopian tube, bile duct, and intestine.

21. The method of any of claims 13 through 16, wherein the conduit is an artificial conduit.

22. The method of any of claims 13 through 16, wherein the conduit is an artificial conduit selected from the group consisting of a catheter, stent, graft, and fistula.

23. The method of any of claims 13 through 16, wherein the conduit is an intracranial artery within a human patient.

24. The method of any of claims 13 through 23, wherein the occlusive material is deposited on the inner wall of the conduit, and wherein said method further comprises bringing the device into searing contact with the occlusive material after activating the expansion means.

25. The method of any of claims 13 through 24, wherein at least one portion of the device is impregnated or coated with a biologically active agent.

26. The method of any of claims 13 through 25, wherein the occlusive material is selected from the group consisting of thrombus, calcification, cholesterol, and plaque.

27. The method of any of claims 13 through 25, wherein the occlusive material is an embolic agent selected from the group consisting of adhesive, gel, silicone rubber, organic elastomer, polymerizable protein solution, silk suture, polyvinyl alcohol particles, polyvinyl alcohol foam, polyurethane foam, acrylic polymer, polyethylene foam, silicone foam, fluorinated polyolefin foam, and ethylene-vinyl-alcohol copolymer.

28. A sheath comprising an elastic tube having a plurality of slits.

29. The sheath of claim 28, wherein the elastic tube comprises a flexible polymer selected from the group consisting of silicone, polyurethane, silicone-polyurethane copolymer, and styrene-ethylene-butylene-styrene (copolymer).

30. The sheath of claims 28 or 29, wherein each slit of said plurality of slits is within the range of about 5  $\mu\text{m}$  and about 20  $\mu\text{m}$  in length.

31. The sheath of any of claims 28 through 30, wherein adjacent slits of said plurality of slits are separated from one another by about 200  $\mu\text{m}$  to about 1000  $\mu\text{m}$ .

32. The sheath of any of claims 28 through 31, wherein said sheath has a length in the range of about 5 millimeters to about 5 centimeters.

33. The sheath of any of claims 28 through 32, wherein said sheath has a diameter within the range of about 1 millimeter to about 1 centimeter.

34. The sheath of any of claims 28 through 33, wherein the sheath has a thickness within the range of about 0.05 millimeters to about 2 millimeters.

35. A device for modeling a luminal occlusion *in vitro*, said apparatus comprising:  
a flexible hollow tube having at least a first end and a second end; and  
an occlusion site within said tube, wherein said occlusion site comprises a receptacle for depositing occluding material.

36. The device of claim 35, wherein said tube comprises a polymer.

37. The device of claims 35 or 36, wherein said tube has a plurality of bends, and wherein each of said bends is separated by at least one of said occlusion site.

38. The device of any of claims 35 through 37, wherein said receptacle has two or more ports connecting said receptacle with said tube.

39. The device of any of claims 35 through 38, wherein said receptacle has an access port that does not connect said receptacle with said tube, and wherein occluding material can be deposited within said receptacle through said access port.

40. A method for testing the efficacy of devices and treatments for treating luminal occlusions, said method comprising:

(a) providing the device of any of claims 35 through 39, wherein the receptacle contains occluding material;

(b) inserting a test device into the tube, or administering a treatment into the tube; and determining the efficacy of the device or treatment in removing, degrading, or otherwise reducing the pathological potential of the occluding material.

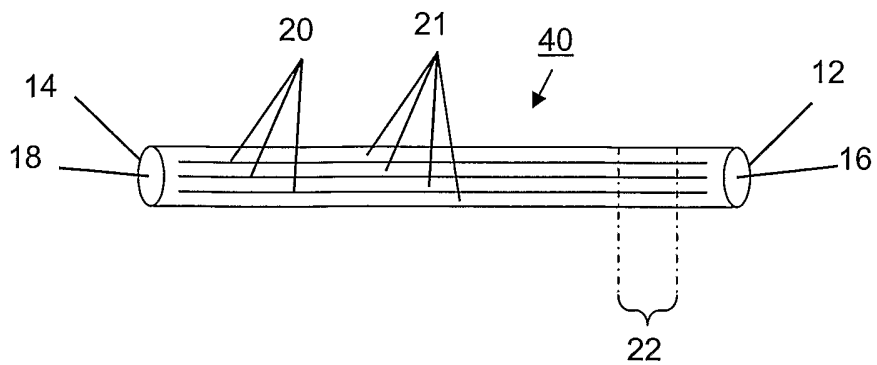

FIG. 1A

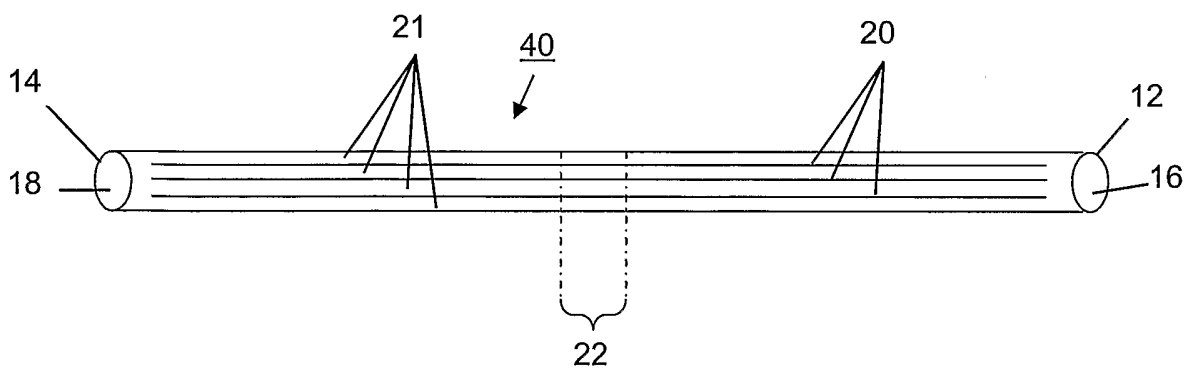

FIG. 1B

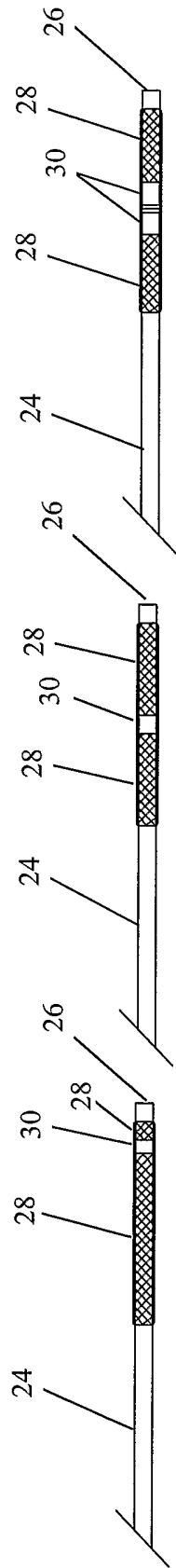

FIG. 2A

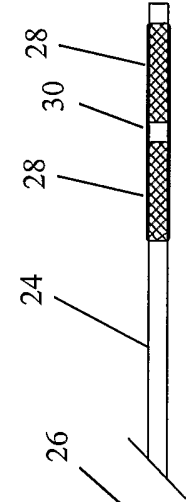

FIG. 2B

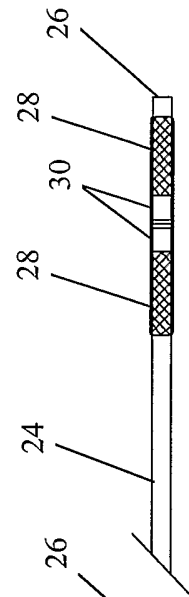

FIG. 2C

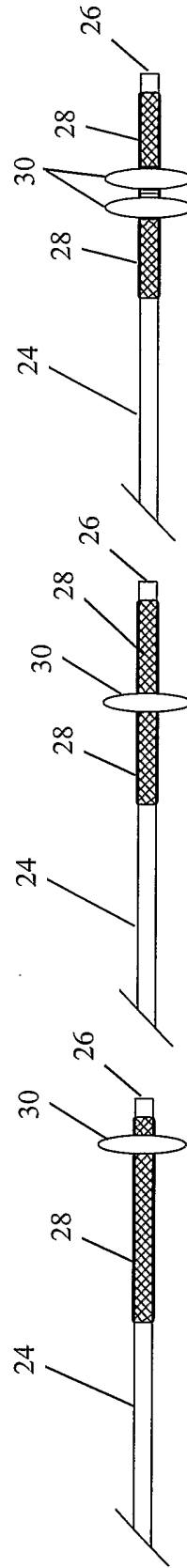

FIG. 3A

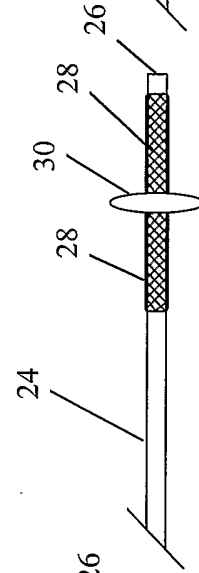

FIG. 3B

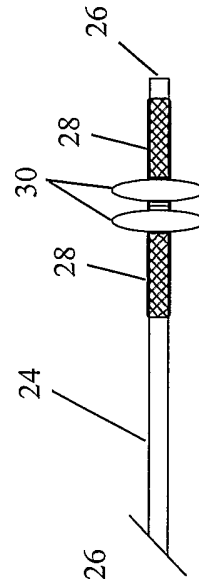

FIG. 3C

3/7

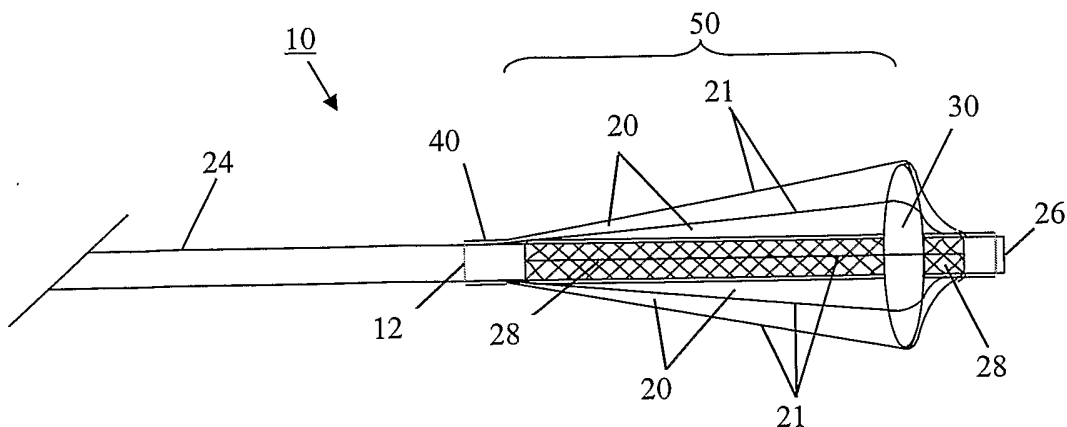

FIG. 4A

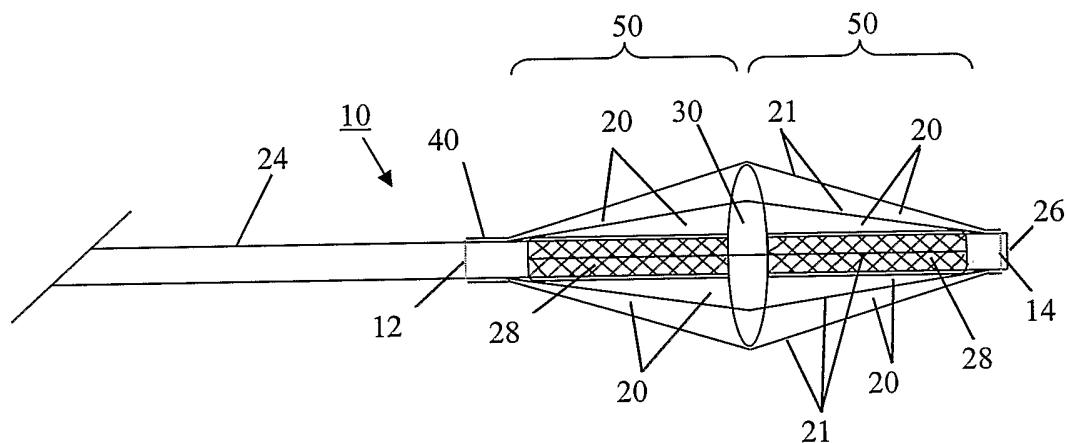

FIG. 4B

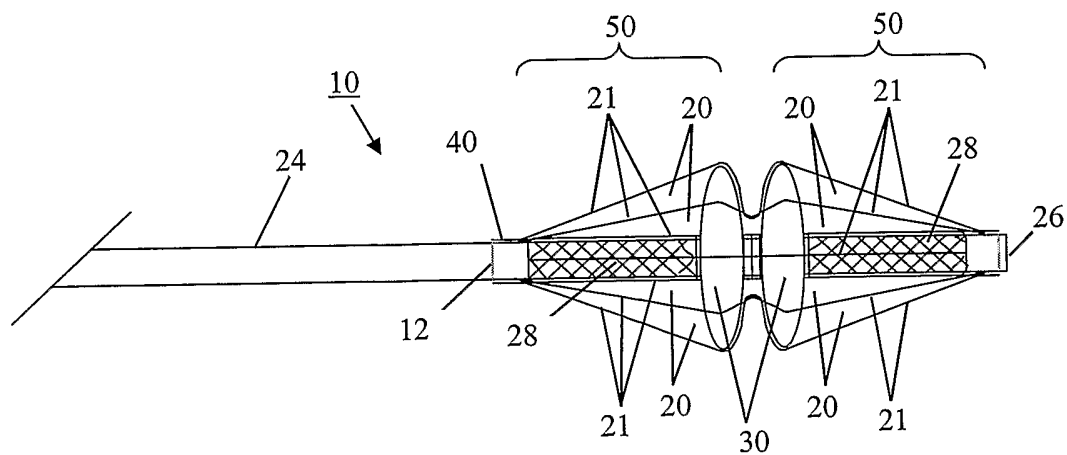

FIG. 4C

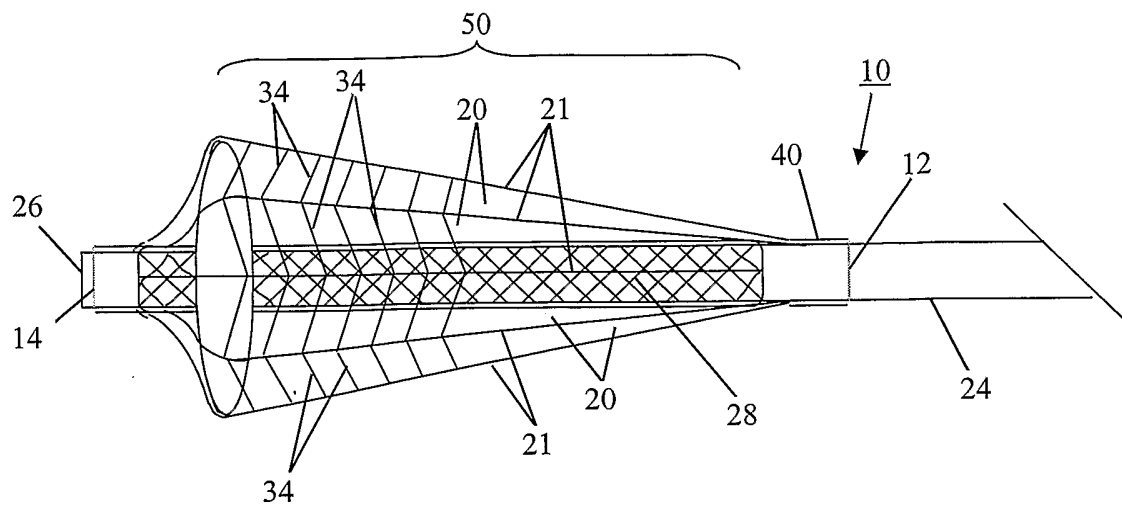

FIG. 5

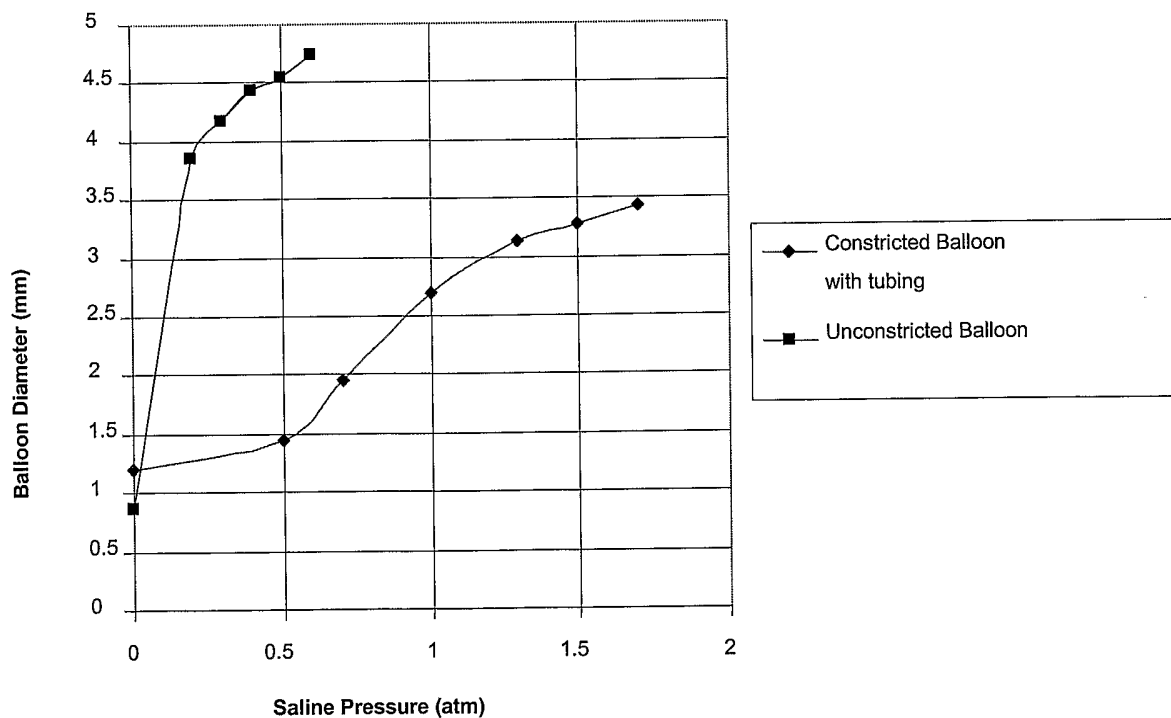

FIG. 6

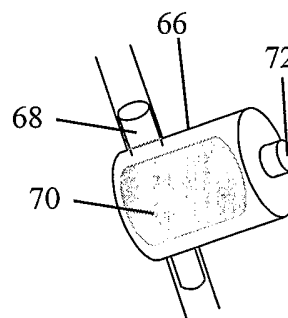
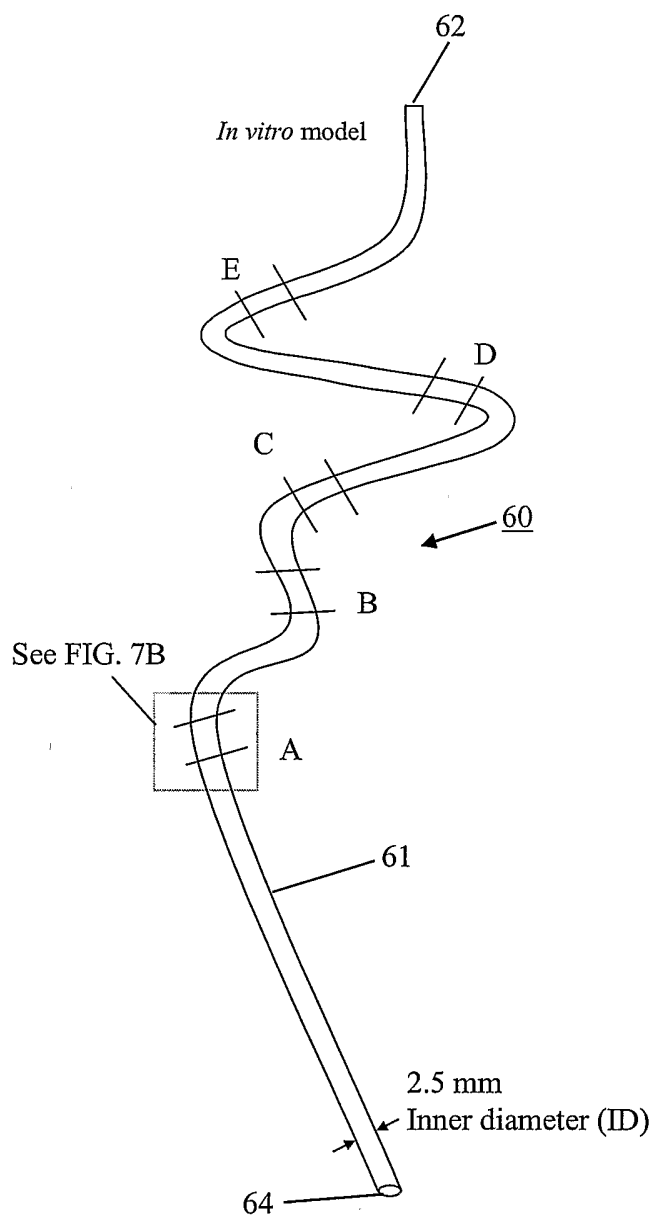

FIG. 7B

FIG. 7A

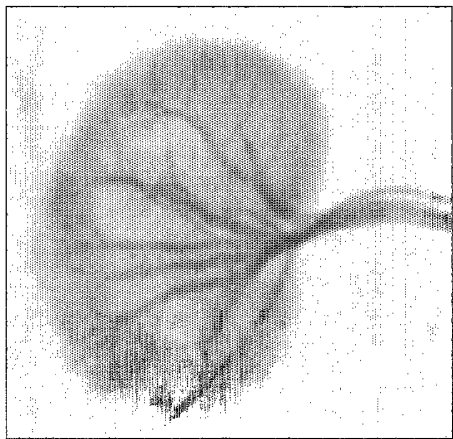

FIG. 8

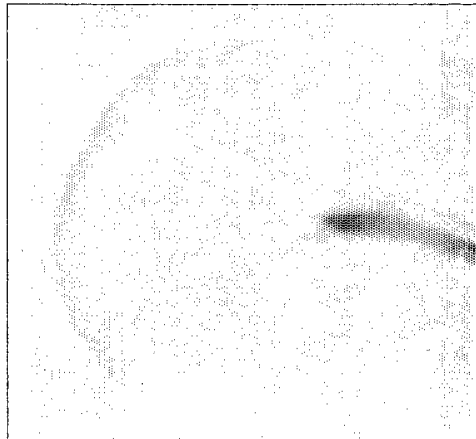

FIG. 9

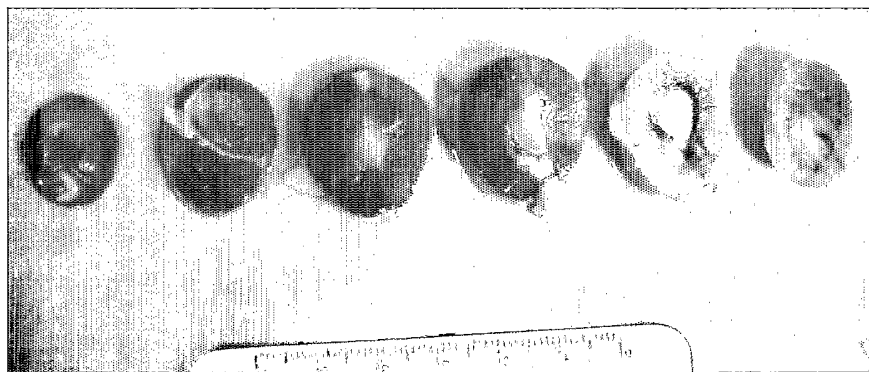

FIG. 10

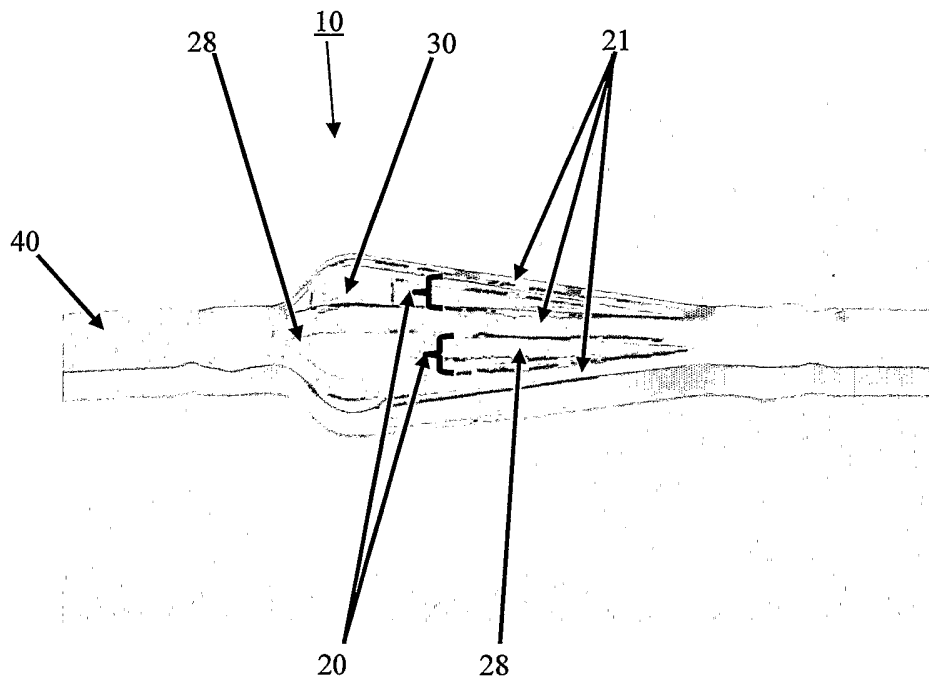

FIG. 11

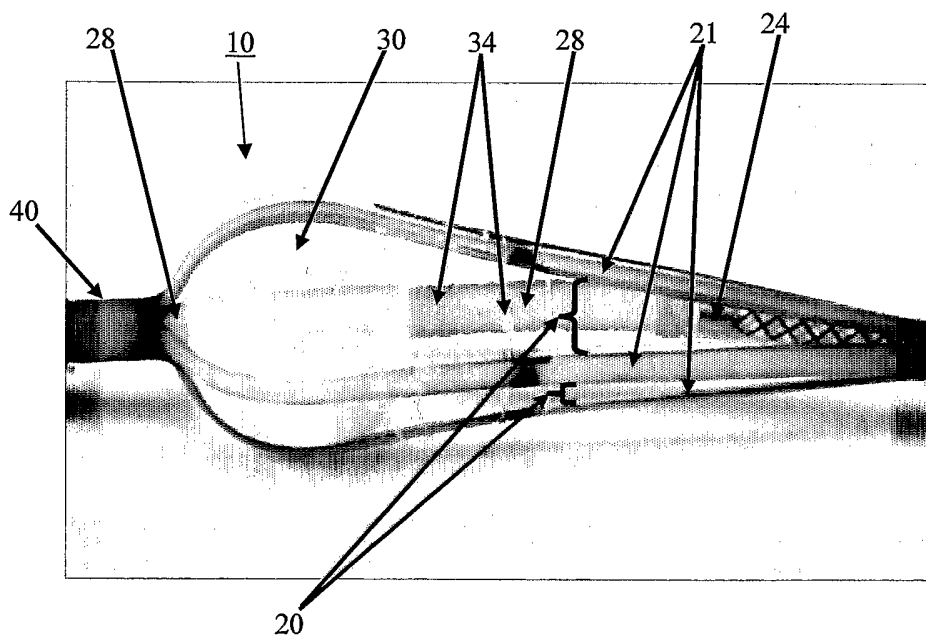

FIG. 12