

L. H. MOISE.
 HAND STAMP HOLDER.
 APPLICATION FILED FEB. 16, 1911.

1,034,485.

Patented Aug. 6, 1912.

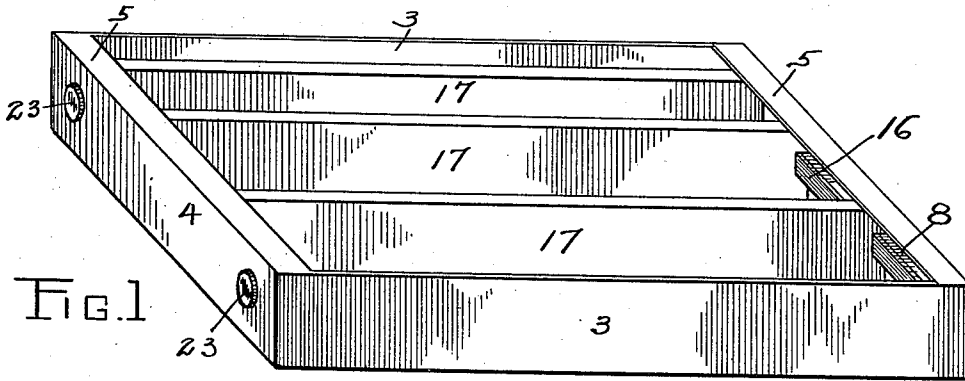

FIG. 1

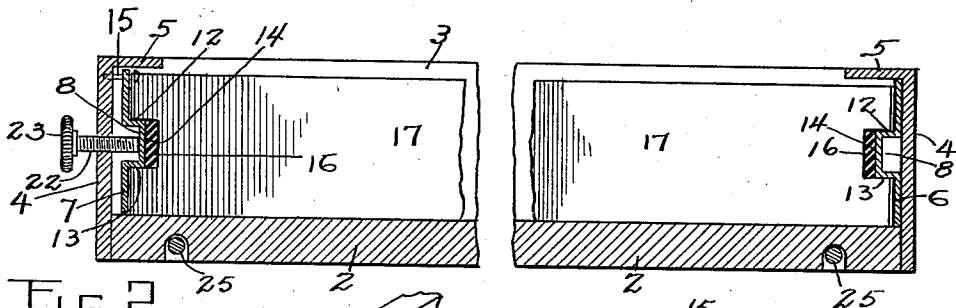

FIG. 2

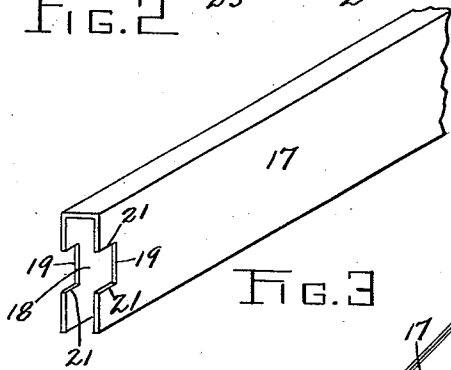

FIG. 3

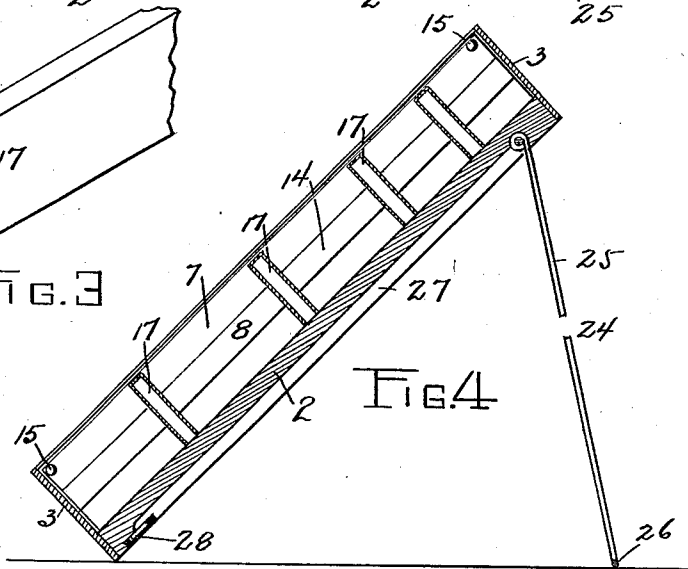

FIG. 4

WITNESSES

H. J. Post.

T. S. Pidwell.

INVENTOR

L. H. MOISE

By *Miller & White*

ATTORNEYS.

UNITED STATES PATENT OFFICE.

LIONEL H. MOISE, OF SAN FRANCISCO, CALIFORNIA.

HAND-STAMP HOLDER.

1,034,485.

Specification of Letters Patent.

Patented Aug. 6, 1912.

Application filed February 16, 1911. Serial No. 609,008.

To all whom it may concern:

Be it known that I, LIONEL H. MOISE, a citizen of the United States, and a resident of the city and county of San Francisco and State of California, have invented certain new and useful Improvements in Hand-Stamp Holders, of which the following is a specification.

The invention relates to improvements in hand stamp holders or racks which are used for holding or containing rubber stamps, or other similar stamps, which are used by being held in the hand and pressed against the surface upon which it is desirable to imprint or impress the legend on the stamp.

Hand stamps are made in many sizes, varying both in width and length, depending upon the legend on the stamp and the size and arrangement of the letters or characters contained therein. In providing a holder for these stamps, therefore, provision must be made for accommodating stamps of various sizes, which sizes are not generally known when the holder is constructed. It is, therefore, advisable to make the holder adjustable so that stamps of varying widths may be held in the least space possible, thereby accommodating a greater number of stamps within a small space.

The object of the invention is to provide a hand stamp holder in which the racks or compartments are adjustable in width.

Another object of the invention is to provide a hand stamp holder in which the racks or bars separating the compartments may be readily moved and firmly clamped in any desired position.

With these and other objects in view, as will more fully hereinafter appear, the invention consists of certain novel features of construction and arrangement of parts hereinafter fully described, illustrated in the accompanying drawings and particularly pointed out in the appended claims, it being understood that various changes in the form, proportions, size and minor details of the structure may be made without departing from the spirit or sacrificing any of the advantages of the invention.

The following description explains at length the nature of my said improvements and the manner in which I proceed to construct and apply the same in the production of a hand stamp holder, reference being had to the accompanying drawings, in which—

Figure 1 is a view in perspective of the

hand stamp holder showing the holder divided into four compartments of unequal width by three cross bars. Fig. 2 is a vertical section on an enlarged scale taken longitudinally through the holder, showing the means for adjusting the position of the cross-bars, the central part of the holder being broken away to reduce the size of the figure. Fig. 3 is a detail in perspective of one end of a cross bar. Fig. 4 is a cross section through the holder, showing the means for supporting it at an angle when desirable.

The holder is box-like in form, being composed of the base 2, the standing sides 3, and the standing ends 4. The height of the sides and ends above the base depends to a certain extent on the height of the stamps, but I find that a height of approximately one inch is sufficient for the general range of stamps. The ends 4 are provided with flanges 5 which overlie a portion of the base 2, thereby forming a recess at the opposite ends of the holder. In these recesses are arranged the strips 6—7 which lie parallel with the ends 4, and extend substantially for the entire width of the holder. These strips 6—7 are preferably made of sheet metal and are formed with a ridge or projecting portion 8 at the center, extending for the full length of the strip. This projecting portion 8 is preferably rectangular in shape, the edges 12—13 lying at right angles to the face of the strip, and the face 14 lying parallel to the face of the strip. The strip 6 may be permanently secured to the holder against the edge. The strip 7 is placed under the opposite flange so that it may be readily moved in or out. To prevent the strip 7 from dropping out of the holder, and possibly becoming lost or displaced, I prefer to attach it loosely to the end by means of the pins 15, which engage the strip at the ends. The length of the pins is such that the strip 7 is movable a sufficient distance sidewise to accomplish its desired objects.

Attached to the faces 14 of the strips 6—7 are strips 16 of a compressible substance, such as rubber, against which the ends of the bars 17 bear. The bars 17 are preferably formed of bent or pressed sheet metal, and are provided on their ends with a depression 18, corresponding substantially to the projection 8 on the strips 6—7. When the bar is in place, the edges 19 engage the rubber strip 16 and the edges 21 lie adjacent to the edges 12—13 and prevent the

bar from falling over when the edges 19 are not pressed against the rubber strip 16. By means of the screws 22 which engage the edge 4 and bear against the strip 7, the strip 5 7 may be moved to cause the edges of the bar to bear firmly against the rubber strip, thereby holding the bar rigidly in place. When it is desired to move the bars to adjust the width of the compartments, the 10 screws 22 are loosened and the bars released from the grip of the rubber strip. The screws are provided with any suitable heads 23, that may be readily turned by the fingers.

As a means of supporting the holder at 15 an angle when it is desirable, I have provided the support 24 which consists of the legs 25 hinged to the base and the cross-piece 26 uniting the legs; the support being generally formed of one piece of wire. 20 When not in use the support is held in the groove 27, by means of the finger 28, all of the parts being so arranged that they lie above the lower surface of the base, and do not contact with the surface on which the 25 holder is placed, when they are not in use.

I claim:

1. In a holder for hand stamps, a base, standing ends projecting above said base, inwardly turned flanges along the upper edge 30 of said ends, strips of compressible material arranged parallel with said ends between the flanges and the base, bars extending longitudinally of the base and adapted to bear against said compressible material, and 35 means permitting the adjustment of said bars.

2. In a holder for hand stamps, a base, standing ends projecting above said base, strips having a raised central portion arranged adjacent to said ends, a strip of compressible material on said strips, bars having ends recessed to correspond to said raised portions and adapted to engage said compressible material, and means for moving one of said strips to clamp the bars. 40 45

3. In a holder for hand stamps, a base, standing ends projecting above said base, inwardly turned flanges on the upper edges of said ends, rectangular bars lying adjacent the ends under said flanges, a strip of compressible material on each of said bars, cross bars lying partly under said flanges and engaging said first mentioned bars, said cross bars being provided with ends recessed to fit said bars, and means for moving one of said compressible material carrying bars to clamp the cross bars. 50 55

4. In a holder for hand stamps, a base, standing ends projecting above said base, strips of compressible material arranged parallel to said ends above said base, open end sheet metal bars extending longitudinally of said base and adapted to bear against said compressible material at their ends, and means for moving said compressible material longitudinally with respect to said bars. 60 65

LIONEL H. MOISE.

Witnesses:

S. PELS,
E. H. PYLE.