

(19)



(11)

EP 1 536 371 B1

(12)

EUROPEAN PATENT SPECIFICATION

(45) Date of publication and mention of the grant of the patent:
02.05.2007 Bulletin 2007/18

(51) Int Cl.:
G06K 15/00^(2006.01) B41J 2/165^(2006.01)

(21) Application number: **04106008.8**

(22) Date of filing: **23.11.2004**

(54) Method of camouflaging defects of printing elements in a printer

Verfahren, um Defekte von Druckelementen eines Druckers zu tarnen

Procédé de camoufler les défauts des éléments d'impression dans une imprimante

(84) Designated Contracting States:
AT BE BG CH CY CZ DE DK EE ES FI FR GB GR HU IE IS IT LI LU MC NL PL PT RO SE SI SK TR

• **Vestjens, Johannes C.G.**
5914 RP Venlo (NL)

(30) Priority: **27.11.2003 EP 03078754**

(74) Representative: **Vanoppen, Ronny R.J. et al**
Océ-Technologies B.V.
Corporate Patents, Postbus 101
5900 MA Venlo (NL)

(43) Date of publication of application:
01.06.2005 Bulletin 2005/22

(73) Proprietor: **Océ-Technologies B.V.**
5914 CC Venlo (NL)

(56) References cited:
EP-A- 1 060 896 EP-A- 1 384 592
WO-A-97/31781 US-B1- 6 508 531

(72) Inventors:
• **Faken, Henry**
5914 SH Venlo (NL)

EP 1 536 371 B1

Note: Within nine months from the publication of the mention of the grant of the European patent, any person may give notice to the European Patent Office of opposition to the European patent granted. Notice of opposition shall be filed in a written reasoned statement. It shall not be deemed to have been filed until the opposition fee has been paid. (Art. 99(1) European Patent Convention).

Description

[0001] The invention relates to a method of camouflaging defective print elements in a printer having a printhead with a plurality of print elements, wherein each pixel of the image is assigned to a print element with which it is to be printed, and image information of a pixel that is assigned to a defective print element is shifted to a nearby pixel position where it can be printed by a non-defective print element. The invention further relates to a printer and to a computer program implementing this method.

[0002] The invention is applicable, for example, to an ink jet printer the printhead of which comprises a plurality of nozzles as print elements. Typically, the nozzles are arranged in a line that extends in parallel with a direction (subscanning direction) in which a recording medium, e.g. paper, is transported through the printer, and the printhead scans the paper in a direction (main scanning direction) perpendicular to the subscanning direction. In a single-pass mode, commonly a complete swath of the image is printed in a single pass of the printhead, and then the paper is transported by the width of the swath so as to print the next swath or in general the single-pass mode is a mode wherein a complete line is printed by only one nozzle. When a nozzle of the printhead is defective, e.g. has become clogged, the corresponding pixel line is missing in the printed image, so that image information is lost and the quality of the print is degraded.

[0003] A printer may also be operated in a multi-pass mode, in which only part of the image information of a swath is printed in a first pass and the missing pixels are filled-in during one or more subsequent passes of the printhead. In this case, it is in some cases possible that a defective nozzle is backed-up by a non-defective nozzle, though mostly on the cost of productivity.

[0004] US-A-6 215 557 discloses a method of the type indicated above, wherein, when a nozzle is defective, the print data are altered so as to bypass the faulty nozzle. This means that a pixel that would have but cannot be printed with the defective nozzle is substituted by printing an extra pixel in one of the neighbouring lines that are printed with non-defective nozzles, so that the average optical density of the image area is conserved and the defect resulting from the nozzle failure is camouflaged and becomes almost imperceptible. This method involves an algorithm that operates on a bitmap, which represents the print data, and shifts each pixel that cannot be printed to a neighbouring pixel position.

[0005] EP-A-0 999 516 discloses a method for generating a print mask which determines a pattern in which the pixels will be printed. This document focuses on multi-pass printing, and the main purpose of the mask is to determine which pixels are to be printed in which pass. In the mask generation process, the image information to be printed is taken into account only indirectly in the form of constraints that determine the construction of the mask. For example, such a constraint may require that a yellow pixel and a cyan pixel directly adjacent thereto

are not printed in the same pass of the printhead, in order to avoid colour bleeding. This document further suggests to construct the masks in such a way that defective nozzles are backed up by non-defective nozzles.

[0006] These known methods require that the locations of the defective nozzles are known before the image processing and mask generating step, respectively, can be performed. Thus, since the information on the locations of the defective nozzles originates from the printhead, either the printer itself must have sufficient processing capabilities for performing the camouflaging method, or the information on the locations of the defective nozzles must be transmitted reversely to the direction of the print data flow to a print driver or the like, where sufficient processing capability is available.

[0007] EP-A-1 060 896 discloses a printer according to the preamble of claim 10, wherein a printhead controller selects different print strategies depending upon whether or not a defective print element has been determined.

[0008] It is an object of the invention to provide a method as set forth in claim 1 with which image defects, that would otherwise be caused by defective print elements, can be camouflaged more efficiently, and a corresponding printer as set forth in claim 10.

[0009] According to the invention, this object is achieved by a method of the type indicated above, which comprises the following steps:

- a) encoding the image information to be printed as a multi-level pixel matrix in which one of a plurality of predetermined pixel values is assigned to each pixel and at least one of said predetermined pixel values is a conditional pixel value encoding a print instruction that depends upon whether or not a neighbouring pixel cannot be printed because of a defective print element,
- b) determining defective print elements of the printer, and
- c) executing said print instruction.

[0010] It is an important feature of the invention that the step (a) which requires substantial data processing capacity and processing time is performed "in advance", i.e. at a stage where the actual locations of the defective nozzles, as determined in the subsequent step (b) are not yet known. Then, what is left to be done when a defective print element has been identified in step (b), either manually or automatically, is to execute the print instructions that have already been encoded in the pixel matrix for the pixels in the neighbourhood of the pixel that cannot be printed. As a consequence, the printer itself is not required to have enhanced image processing capabilities nor to perform time-consuming processing steps in order to camouflage the effect of the defective nozzles. The more time consuming processing operations involved in step (a) may be performed at a location remote from the printer and the result may be buffered, if necessary, while

the printer is busy with another print job. This leads to a considerable increase in the productivity of the printer, especially in a multi-user scenario. Moreover, since the step (a) does not depend on the exact locations of the nozzle defects, it is possible to perform this step even before it is known to which printer the data will be sent, i.e. the print data obtained as a result of step (a) are portable among different printers.

[0011] The hardware, which is used for performing the step (a) and which may be installed in the printer itself or remote from the printer, will preferably be of a type that is suitable for high-speed image processing and may also be used for other complex image processing tasks such as halftoning, gamma correction, contrast enhancement, image segmentation and the like. Thus, the data processing involved in the step (a) can be performed at high speed.

[0012] More specific optional features of the invention are indicated in the dependent claims.

[0013] In a simple embodiment, the plurality of predetermined pixel values of the multi-level pixel matrix comprise three values: an unconditional value "0" which stands, in any case, for a white pixel, a pixel value "2" which, in any case, stands for a black pixel, and a conditional pixel value "1", which stands for a black pixel, i.e. the print instruction "print", if at least one of the neighbouring pixels corresponds to a defective print element, and which stands for a white pixel, i.e. the print instruction "don't print", otherwise.

[0014] In other embodiments, the pixel matrix may have a larger number of predetermined pixel values. For example, in case of an ink jet printer which is capable of dot size modulation, e.g. capable of printing either a small dot or a large dot for each non-white pixel, the predetermined pixel values may comprise the unconditional pixel values "0", "2", and "4", for printing no dot, a small dot, and a large dot, respectively, and the conditional pixel values "1" and "3" for printing a small dot and a large dot, respectively, when one or more non-printable pixels are present in the neighbourhood.

[0015] The print instructions encoded by the conditional pixel values may also be of a more complex nature and may, for example, specify that a simple error diffusion step (which does not require much processing capacity and time) shall be performed for the pixels adjacent to non-printable pixels. Then, the pixel value assigned to a specific pixel will indicate the weight that is given to this pixel in the error diffusion process.

[0016] If the printer operates in a single-pass mode, then a defect of a single nozzle will lead to a complete line of non-printable pixels. In this case, the conditional pixel values will be interpreted as "don't print" for all the pixels except those in the line or lines immediately above and/or below the non-printable line. Then, if the original image data to be printed are binary data, where each pixel has either the value "0" or "1", the multi-level pixel matrix may be constructed as follows. For every pixel having the value "1" in the original print data, the pixel

value is changed to an unconditional value, e.g. "2", which stands for a pixel to be printed, and the pixel or pixels immediately above and/or below this pixel obtain a conditional pixel value (e.g. "1").

[0017] In multi-pass printing, such as two-pass printing for example, each pixel line is printed with two different nozzles, and if one of these nozzles is defective, only every second pixel in the line will be missing. Thus, any given non-printable pixel will generally be surrounded by four printable pixels, i.e. the pixels above and below and also its left and right neighbours. Then, the multi-level pixel matrix may be constructed as follows. Every pixel with the value "1" in the original print data is changed to the unconditional value which stands for a pixel to be printed, and the pixel value(s) of one or more of the neighbouring pixels will be incremented by one, provided that its original value was "0". If, for example, four neighbouring pixels are incremented, i.e. the pixels above, below, to the left and to the right of the original "1"-pixel, then the unconditional value "4" will stand for a pixel to be printed in any case, and the conditional values of a pixel may be "1", "2", or "3", depending on how many original "1" pixels are found in its surroundings.

[0018] The height of the unconditional pixel value will determine the likelihood and/or the intensity (e.g. dot size) with which a pixel will be printed.

[0019] Preferred embodiments of the invention will now be explained in conjunction with the drawings, in which:

Fig. 1 is a schematic view of an ink jet printer to which the invention is applicable;

Figs. 2A-D are diagrams of an area of 8x8 pixels of an image, illustrating a first embodiment of the invention;

Figs. 3A-C are diagrams of an area of 8x8 pixels of an image, illustrating a second embodiment of the invention;;

Figs. 4A-D are diagrams of an area of 8x8 pixels of an image, illustrating a third embodiment of the invention;

Figs. 5A-C are diagrams illustrating embodiment involving error diffusion;

Figs. 6A-C are diagrams illustrating an embodiment adapted to a two-pass print mode; and

Figs. 7A,B are diagrams illustrating another embodiment adapted to the two-pass mode.

[0020] As is shown in figure 1, an ink jet printer comprises a platen 10 which serves for transporting a recording paper 12 in a subscanning direction (arrow A) past a printhead unit 14. The printhead unit 14 is mounted on a carriage 16 that is guided on guide rails 18 and is movable back and forth in a main scanning direction (arrow B) relative to the recording paper 12. In the example shown, the printhead unit 14 comprises four printheads 20, one for each of the basic colours cyan, magenta, yellow and black. Each printhead has a linear array of nozzles 22

extending in the subscanning direction. The nozzles 22 of the printheads 20 can be energised individually to eject ink droplets onto the recording paper 12, thereby to print a pixel on the paper. When the carriage 16 is moved in the direction B across the width of the paper 12, a swath of an image can be printed. The number of pixel lines of the swath corresponds to the number of nozzles 22 of each printhead. When the carriage 16 has completed one pass, the paper 12 is advanced by the width of the swath, so that the next swath can be printed.

[0021] The printheads 20 are controlled by a printhead controller 24 which receives print data in the form of a multi-level pixel matrix from an image processor 26 that is capable of high speed image processing. The image processor 26 may be incorporated in the printer or in a remote device, e. g. a print driver in a host computer. The printhead controller 24 and the image processor 26 process the print data in a manner that will be described in detail hereinbelow. The discussion will be focused on printing in black colour, but is equivalently valid for printing in the other colours.

[0022] Figure 2A shows an array of 8x8 pixels 28 of a binary image 30 that is to be printed with the printer shown in figure 1. The print data representing the binary image 30 are created in or supplied to the image processor 26. In the example shown, the image 30 comprises a thin horizontal line 32 having only a width of one pixel, and a thin diagonal line 34. The pixels having a binary value "1", i.e. the pixels to be printed in black, are indicated by hatching.

[0023] Figure 2B shows a printed image as it would be obtained by printing the binary image 30 when one of the nozzles 22 of the printhead 20 fails. In figure 2B, as in the rest of this specification, pixel lines are indicated by their line index ranging from $i-4$ to $i+3$, and pixel columns are indicated by their column index ranging from $j-4$ to $j+3$. Individual pixels will be referred to by their coordinates, i.e. a pair of a line index and a column index such as (i, j) .

[0024] It has been assumed in figure 2B that the nozzle 22 that is responsible for printing the line i is defective. As a result, the black line 32 of figure 2A is missing in the printed image.

[0025] Figure 2C shows a multi-level pixel matrix 38, a three-level pixel matrix in this case, which is obtained by applying an image processing routine to the binary image 30 by means of the image processor 26. In the pixel matrix 38, each pixel may have one of three pixel values: "0", "1" and "2". The image data representing the pixel matrix 38 are transmitted to the printhead controller 24 and will be interpreted by the printhead controller as follows. A pixel value "0" means that the pixel shall not be printed, i.e. shall be left blank or white. A pixel value of "2" means that the pixel shall be printed (black). A pixel value of "1" means that the pixel shall be treated as a "0"-pixel and shall not be printed, unless a nozzle failure occurs for one of the pixel lines immediately above and below this pixel. In the latter case, the pixel shall be treat-

ed as a "2" pixel and shall be printed. For example, the value "1" of the pixel $(i-1, j-1)$ means that this pixel shall only be printed if either the nozzle needed for printing the line i or the nozzle needed for printing line $i-2$ is defective.

[0026] The printer may be arranged for automatically detecting nozzle failures, as is generally known in the art. Thus, the information needed for determining whether or not a nozzle is defective will be available in the printhead controller 24 which interprets the pixel matrix 38. As an alternative, nozzle failures may of course be detected manually by an operator who will to this end analyse a specific test image and will enter an information identifying the defective nozzles into the printhead controller 24 by suitable input means.

[0027] In the example shown in figure 2C, the pixel matrix 38 is derived from the binary image 30 by means of the following algorithm. Every "1" (black pixel) in the binary image 30 is translated into a "2" in the pixel matrix 38. For example, this leads to the pixel value "2" for the pixel $(i+3, j-4)$ in figure 2C. In addition, the pixel immediately below this "2"-pixel is changed from "0" to "1". This is the case, for example, for the pixel $(i+2, j-4)$. If, however, the pixel immediately below the "2"-pixel was a black pixel already, it will be changed to "2" as every other black pixel. An example for this is the pixel $(i-1, j)$.

[0028] A printed image 40 obtained as a result of this image processing step and its interpretation in the printhead controller 24 is shown in figure 2D. It can be seen that, thanks to the algorithm described above, the image information of the black line 32 is not lost, but is replaced by a black line 32' immediately below the defective nozzle. In other words, the line 32 is shifted by one pixel, and this shift will be hardly perceptible by the human eye. In all the pixel lines that are not directly adjacent to the line i of the defective nozzle, (lines $i-4$ to $i-2$, $i+2$ and $i+3$) the original image information is preserved without any changes. In line $i+1$, an additional black pixel $(i+1, j-3)$ occurs close to the position, where the diagonal line 34 crosses the horizontal line 32'. This additional black pixel stems from the "2"-pixel $(i+2, j-3)$ in figure 2C, which pixel has caused an "1" occurring immediately therebelow. The main purpose of this "1" was to replace the "2"-pixel in line $i+2$ in case that the nozzle for line $i+2$ should fail. However, since the printhead controller 24 of this embodiment does not distinguish whether a line is located below or above a defective line, the pixel $(i+1, j-3)$ will be printed in black, even though there is no defect in the line $i+2$. This behaviour leads to a slight overcompensation of the nozzle defect, but is highly welcome here, because it camouflages, to some extent, the gap occurring in the diagonal line 34 in pixel line i .

[0029] The algorithm illustrated in figure 2C is particularly useful for images, such as CAD graphics, which include thin horizontal lines. Of course, instead of shifting the line 32 one pixel downwardly, an equivalent strategy would be to shift this line one pixel upwardly.

[0030] If a horizontal line has a width of two pixels and covers, for example, the lines i and $i-1$, then the algorithm

shown in figure 2C would have the effect that the pixel is thinned from a width of two pixel to a width of one pixel (the pixels in line $i-2$ would be changed to "1", but would not be printed, because the nozzle defect is two pixels away). This would be quite an acceptable result. In this case, however, the alternative strategy, wherein a "1" is added above each "2"-pixel, would have the result that the two pixel wide line would be split into two one-pixel-lines separated by a one pixel gap.

[0031] A similar gap and a one-pixel line would occur in the case that the line i forms the upper boundary of a solid black area in the original image 30. In this case, the occurrence of a thin line isolated from the rest of the black area would be less favourable.

[0032] Another possible strategy would be to insert a "1" pixel alternatingly above and below each "2" pixel. This strategy would be suitable for example for images consisting of extended grey areas, but would be unfavourable in case of horizontal high-contrast boundaries, because the boundary would become rugged if a nozzle failure occurs right at the boundary.

[0033] It will therefore be preferable to adopt the most suitable strategy depending on the contents of the image 30 to be processed. This can be achieved in a straightforward manner user defined setting or by employing image processing routines which comprise, for example, image segmentation in order to classify different types of image elements, such as thin lines, high-contrast boundaries, grey-shade areas and the like. In general, the aim of the image processing algorithm will be to obtain a printed image 40 that resembles as far as possible the original image 30, regardless of the position where the nozzle failure occurs.

[0034] Figures 3A-C illustrate an embodiment, in which "1"-pixels are added alternatingly above and below each "2" pixel. As mentioned already, this embodiment is particularly suitable for a binary image 30, as shown in figure 3A, in which the black pixels appear to be scattered randomly over the image area. The corresponding pixel matrix 38 shown in figure 3B is constructed almost in the same way as the pixel matrix in figure 2B, with the only difference that, for the "2"-pixels, the corresponding "1" pixels are inserted alternatingly above and below the "2" pixel, as is symbolised by arrows in figure 3B. The "1"-pixel that would be created by the "2" pixel ($i+3, j+2$) is not visible here, because it is outside of the image area.

[0035] The printhead controller 24 interprets the pixel matrix 38 in the same way as in figures 2B,C. As is shown in figure 3C, the resulting printed image 40 is hardly distinguishable from the original image 30, in spite of the nozzle failure in line i . Again, it is observed that the sum of black pixels in the lines $i-1, i$, and $i+1$ in figure 3C is slightly larger than in figure 3A, because "1"-pixels are also created by black pixels in the lines $i-2$ and $i+2$. If this effect is not desirable, for example in case of image areas with a relatively high average density, the image processing algorithm may be modified by suppressing some of

the additional "1"-pixels. For example, when the pixels are gone through line by line, the first "2"-pixel may create a "1" pixel above, the second "2"-pixel creates a "1" pixel below, and the third "2"-pixel does not create any "1" pixel at all, and then the sequence will be repeated.

[0036] Another possible modification that may be suitable for relatively dark image areas would be that the "1" pixel is not always inserted immediately above or below the "2" pixel, but is shifted to an empty position in the vicinity of the "2" pixel.

[0037] Another embodiment will now be described in conjunction with figures 4A-D. In the binary image 30 shown in figure 4A, the lines $i-2$ to $i+1$ form an extended dark area with an average density of 50%. An isolated black pixel is present at ($i-4, j$). Figure 4B shows the corresponding printed image 36 that would be obtained if the nozzle failure in line i were not camouflaged. Figure 4C shows a corresponding multi-level pixel matrix 38 which in this case is a four-level matrix. Here, the pixel value "3" means that a black pixel shall be printed unconditionally. The pixel value "0" stands again for pixels that are to be left blank, unconditionally. The pixel value "1" means that the pixel shall be printed in black on condition that a nozzle failure occurs in the line immediately below. Conversely, the pixel value "2" means that the pixel shall be printed in black on condition that a nozzle failure occurs in the line immediately above.

[0038] When constructing the pixel matrix 38 of figure 4C, every black pixel in the original image 30 is changed to "3". The algorithm for assigning the conditional pixel values "1" and "2" is more complex in this case. Since the lines $i+2$ and $i+3$ include no black pixels, the line $i+1$ forms the upper boundary of a grey area. for thos reason, no "1"-pixels are provided in line $i+2$. Thus, even when a nozzle failure would occur for the line $i+1$, this would not be compensated by any black pixels in line $i+2$. Nor would there be any additional black pixels in line i for compensating the nozzle failure, because the line i does not contain any "2"-pixels. Thus, when the nozzle for line $i+1$ fails, this line is simply left white without any compensation, with the result that the boundary between the dark and the white area is shifted by one pixel. This has the advantage that a smooth appearance of the boundary is preserved.

[0039] In line i , a first "3" occurs at the position $j-3$. For this reason, a "1" has been assigned to the pixel ($i+1, j-3$). Thus, when the nozzle for line i fails, an additional black pixel will be printed in the line $i+1$, as is shown in figure 4D. The next "3"-pixel in line i is at the position $j-1$. Here, the pixel value "2" is assigned to the pixel ($i-1, j-1$). Thus, a nozzle failure in line i will in this case be compensated by an extra pixel in the line $i-1$ below, as is also shown in figure 4D. For the subsequent "3"-pixels in line i , a "1" and a "2" are alternatingly inserted in lines $i+1$ and $i-1$, respectively. The same algorithm is also applied to the "3"-pixels in line $i-1$.

[0040] The line $i-2$ forms the lower boundary of the grey area, and the smooth appearance of this boundary

should be preserved. For this reason, similarly as for line $i+1$, there are no "2"-pixels in line $i-3$, and the pixels above the "3"-pixels at $j-3$ and $j+1$ are left at "0". Thus, if a nozzle failure should occur in the boundary line $i-2$, this failure would not be compensated at all.

[0041] The isolated "3"-pixel in line $i-4$ is treated in the same way as the pixels in lines i and $i-1$. Thus, an "1" pixel is inserted at the position $(i-3, j)$. In case of a nozzle failure for line $i-4$, the missing pixel would be shifted one position upwardly.

[0042] When the algorithm described above for lines i and $i-1$ in figure 4C is applied to a larger number of subsequent pixel lines, then, depending on the image contents, a conflict situation may occur for specific pixels. For example, a "3" above such a pixel may require the pixel value "2", whereas a "3" below this pixel may require a pixel value "1" for the same pixel. This conflict may be resolved by giving priority to either the "2" or the "1". In this case, however, a nozzle failure for one of the two adjacent lines may not be compensated completely.

[0043] In view of this problem, a more elaborated embodiment may provide that all black pixels in the original image 30 obtain the pixel value "4" instead of "3". Then, the pixel value "3" would indicate that a black pixel shall be printed on condition that a nozzle failure occurs in anyone of the adjacent upper and lower lines. Thus, if a "2" is required because of a black pixel in the upper line, and at the same time a "1" is required because of a black pixel in the lower line, then the values "1" and "2" are added to give the conditional pixel value "3".

[0044] The embodiments described above require only a minimum of data processing in the printhead controller 24. All that has to be done for printing a given pixel is to decide whether a nozzle failure occurs in the line above or below this pixel and then to adopt the pertinent interpretation for the conditional pixel values. This can for example be achieved by a simple hardware implementation with a network of AND and OR gates.

[0045] Figures 5A-C illustrate a modified embodiment which requires slightly more processing capability of the printhead controller 24. The image processor 26 constructs the pixel matrix 38 shown in figure 5B on the basis of the binary image 30 shown in figure 5A. The pixel matrix is again a three-level matrix, wherein the pixel value "2" is assigned to each of the black pixels in the image 30. In addition, for each of the "2"-pixels in figure 5B, a "1" is inserted in the line immediately above and another "1" in the line immediately below. In case of interference, as for example for the pixel $(i+2, j+2)$ in figure 5B, the pixel value is left at "1", although both the pixels $(i+3, j+2)$ above and $(i+1, j+2)$ below have the value "2".

[0046] When no nozzle failure occurs, the printhead controller 24 interprets the pixel value "2" as black and the pixel values "0" and "1" as white. When, however, a nozzle failure occurs in the line i , as shown in figure 5C, a special treatment is applied to the lines $i-1$ and $i+1$. In the example shown, this special treatment consists of a simple one-dimensional error diffusion process with

threshold 2. Starting with the first pixel $(j-4)$ in line $i+1$, the pixel value "1" is below the threshold 2, so that the pixel is left white in figure 5C. The rest (1) is added to the pixel value of the next pixel $(i+1, j-3)$. Since the latter pixel value is "0", the sum is still below the threshold, and this pixel is left white as well. The rest (1) is then added to the pixel value "2" of the next pixel $(i+1, j-2)$. Since the sum (3) is now larger than the threshold 2, the pixel is printed in black, and the sum is decremented by the threshold value 2, giving a rest of 1. The same procedure then applies to the next pixel $(i+1, j-1)$, giving again a black pixel and a rest of 1. For the next pixel $(i+1, j)$ the sum reaches the threshold value 2, so that this pixel will be printed in black (although this pixel was white in figure 5A). Since there is no rest to be added to the next pixel $(i+1, j+1)$, this pixel is left white. The procedure described above is iterated for the subsequent pixels in line $i+1$ and then in line $i-1$, with the rest from the pixel $(i+1, j+3)$ being carried over to the first pixel $(i-1, j-4)$ in the next line. The resulting printed image 40 is shown in figure 5C. As a result of the error diffusion process and the selection of the threshold, the average optical density in the lines $i-1$, i , and $i+1$ in figure 5C will approximately be equal to the average optical density in the corresponding lines in figure 5A, so that the nozzle failure is compensated. Compared to the previous embodiments, the embodiment described here has the advantage that the image information which has been spread from line i to the adjacent lines will not be lost, even when the position right above or below is already occupied by a black pixel. Thanks to the error diffusion, the image information will instead be propagated to the next empty pixel position.

[0047] This embodiment can of course be modified in various ways. For example, it is possible to adopt more complex error diffusion schemes, including also 2-dimensional error diffusion (where part of the error is diffused, for example, from line $i+1$ to $i-1$). The threshold employed in the error diffusion process does not have to be an integral number. It would be possible for example to adopt a threshold of 1.8 or 2.2, resulting in a slight tendency towards overcompensation and undercompensation, respectively, of the nozzle failure.

[0048] The error diffusion process may also be replaced by other suitable algorithms. For example, the pixel values in lines $i-1$ and $i+1$ may each be compared to a respective threshold which varies randomly between 0 and 2, and a black pixel may be printed, when the threshold is exceeded. The result will be that a "1"-pixel will be printed as a black pixel with a probability of 50%. Since every "2" pixel in line i generates two "1" pixels, one in line $i-1$ and one in line $i+1$, the average density will be preserved if each of these "1" pixels is printed with a probability of 50%.

[0049] Whereas the embodiments described above are adapted to a single-pass print mode, in which a nozzle failure leads to the loss of a complete pixel line, the invention is also applicable to multi-pass printing, where a plurality of nozzles contribute to a given pixel line, so that

a failure of a single nozzle leads only to a loss of a fraction of the pixels of the line. If no substantial post-processing shall be performed in the printhead controller 24, the methods for multi-pass printing will be analogous to what has been described in conjunction with figures 2 to 4, possibly with the additional feature that, in the construction of the pixel matrix, a distinction is made as to which of the nozzles that contribute to the same line is defective.

[0050] Figures 6 and 7 illustrate two embodiments that are specifically adapted to two-pass printing and involve some post-processing such as error diffusion in the printhead controller 24.

[0051] The binary image 30 shown in figure 6A is processed in the image processor 26 so as to construct the pixel matrix 38 shown in figure 6B. This pixel matrix is a 8-level matrix having the pixel values ranging from "0" to "8". The construction scheme for the pixel matrix 38 is symbolically shown in figure 6C: Every black pixel "1" of the original image 30 is changed to a "4", and the pixel values of the upper, lower, left and right neighbours of this pixel are increased by 1. In case of interference, the increments of the pixel value are summed. Thus, the pixel value "2" of the pixel (i, j-3) in figure 6B is obtained by adding a "1" from pixel (i, j-4) and another "1" from pixel (i, j-2). Depending upon the configuration of black pixels in the image 30, the sum may reach the maximum value of "8" (a "4" for the central pixel plus four "1"s from four black neighbours).

[0052] The pixel matrix 38 is interpreted and post-processed in the printhead controller 24. Again, it shall be assumed that a nozzle failure occurs in line i. However, in the two-pass mode, this will have the effect that every second pixel in line i can still be printed. The remaining pixels that cannot be printed, have been crossed out in figure 6B. By way of example, it is assumed that these are the pixels at positions j-4, j-2, j and j+2. Since three of these pixels happen to be black pixels in figure 6A, the loss of image information that needs to be compensated amounts to 3 pixel.

[0053] The pixels in the lines i-1, i and i+1 are subjected to error diffusion with threshold 5. In this error diffusion process, the non-printable pixels in line i are skipped. When the "1"-pixels and "2"-pixels occurring in the lines i-1, i+1 and at the printable positions in line i are summed, the result is 18. Because of the threshold 5, the number of additional pixels that will be printed in these lines is $18/5 = 3$ rest 3. Thus, the three missing pixels in line i will be compensated by three extra pixels in the neighbourhood, and the rest of 3 will be discarded.

[0054] The reason for selecting the threshold value 5 in this embodiment will be explained in conjunction with figure 6D. The upper block in figure 6D shows the lines i-1, i and i+1 of an original binary image, wherein lines i-1 and i+1 are white, and i is a continuous black line, black pixels being indicated by the pixel value "1". Here, the total number of black pixels in lines i-1 to i+1 is 8.

[0055] The lower block in figure 6D shows the corresponding pixel matrix as constructed in accordance with

figure 6C. Summing the pixel values "1", "6", and "5" of all the pixels that participate in the error diffusion gives 39. With the threshold value 5, the number of pixels that will actually be printed is $39/5 = 7$ rest 4, and this is the best match to the total number of 8 pixels that should have been printed in line i.

[0056] As the error diffusion is used very locally and requires less computing power the error diffusion scheme and the threshold value may be varied as desired.

[0057] The embodiment shown in figure 6 may in some rare cases lead to artefacts in the form of extra pixels that are added to the original image 30, even when no nozzle failure occurs. As an example, consider the case that the pixel (i, j) is white in the original image 30, but the four adjacent pixels (i+1, j), (i, j-1), (i, j+1) and (i-1, j) are black. Then, the increments from the surrounding pixels will sum up to a pixel value of "4" for the pixel (i, j), and this pixel value would unconditionally be interpreted as black, so that the white pixel would be turned into a black one, even when no nozzle failure occurs. This effect may be compensated for by providing appropriate modifications in other image processing steps such as halftoning, gamma correction and the like. As an alternative, the embodiment may be modified as follows: Instead of encoding an original black pixel by the pixel value "4", it is encoded by the pixel value "5". This pixel value or a higher pixel value can only be reached when the original pixel was black already. In the printhead controller 24, only pixel values of "5" or higher will now be interpreted unconditionally as black, and the pixel value "4" is interpreted as white, where no error diffusion is performed. In the error diffusion process, the pixel value of "5" will only be counted as 4, a pixel value of "6" will be counted as 5, and so on up to the highest possible pixel value of "9", which will be counted as 8.

[0058] The figures 7A and B illustrate another embodiment, which is also adapted to a two-pass print mode. The binary image 30 shown in figure 7A is the same as in figure 6A. However, as is shown in figure 7B, the black pixels of the binary image are in this case translated only into the pixel value "2", and an increment of "1" is added only to one of its four neighbours. The selection of the neighbour, to which the increment of "1" is added, rotates counter-clockwise, when the "2"-pixels are gone through line by line. This counter-clockwise rotation is indicated by arrows in figure 7B. Thus, for the first "2"-pixel (i+3, j+2), an increment of "1" is added only to its right neighbour (i+3, j+3). For the next "2"-pixel (i+2, j-3) an increment is only added to its upper neighbour (i+3, j-3), and so on. In this case, the incremented pixel values may range from "0" to "4", and the values "2", "3" and "4" will be interpreted as black pixels, where no error diffusion is performed. The pixels in the line i of the nozzle failure and the lines immediately above and below are subjected to error diffusion with a suitable threshold value. A consideration similar to the one explained in conjunction with figure 6D shows that a threshold value of 3 would be suitable in this case.

[0059] In figure 7B, it has been assumed that the nozzle failure causes defects in the pixel positions (i, j-3), (i, j-1), (i, j+1), and (i, j+3). Since these pixels happen to be white, anyway, in figure 7A, no extra black pixels would have to be added in order to compensate for the nozzle failure. As can be seen in figure 7A, the total number of black pixels in the lines i-1, i and i+1 is 5. Summing the pixel values of the printable pixels in these lines in figure 7B gives 14, and the number of black pixels that will actually be printed, if the error diffusion threshold is 3, will be $14/3 = 4$ rest 2, which is very close to the ideal number of 5.

[0060] On the other hand, if the other one of the two nozzles that are used for printing the line i would be defective, the non-printable pixels would be (i, j-4), (i, j-2), (i, j) and (i, j+2). This would be almost the "worst case" because three of the four pixels happen to be black. In this case, the sum of the pixel values of the printable pixels would be 10, and the number of pixels that are actually printed would be $10/3 = 3$ rest 1. This is smaller than the ideal number 5 but larger than the number (2) of black pixels that would be obtained without any failure compensation. In other words, at least one extra black pixel would be added in the three lines from i-1 to i+1.

[0061] It might be concluded from the above examples that the nozzle failure is somewhat undercompensated in this embodiment. It should be noted however that, in these examples, the black pixels in the lines i-2 and i+2 do not contribute to the pixel values in the lines i-1 and i+1, because, accidentally, the "2"-pixel (i+2, j-3) leads to an increment in the upper line i+3, and the "2"-pixel (i-2, j) leads to an increment in the lower line i-3. The opposite result, leading to an extra "1" in each of the lines i-1 and i+1 could however have occurred with the same likelihood. Thus, considering a larger image area, the average result would be better than in the specific examples that have been discussed here.

Of course, the modifications that have been explained in conjunction with figure 6 can equivalently be applied to the embodiment of figure 7. Moreover, it will be possible in both embodiments to consider not only the four neighbouring pixels, i.e. the left and right, upper and lower neighbours, but to spread the pixel value of a given pixel to all its eight neighbours, including the "diagonal" neighbours such as the pixels (i+1, j-1), (i+1, j+1), (i-1, j-1) and (i-1, j+1) for the central pixel (i, j).

Claims

1. A method of camouflaging defective print elements (22) in a printer having a printhead (20) with a plurality of print elements (22), wherein each pixel (28) of the image is assigned to a print element (22) with which it is to be printed, and image information of a pixel that is assigned to a defective print element is shifted to a nearby pixel position where it can be printed with a non-defective print element, **charac-**

terised by the steps of:

- a) encoding the image information (30) to be printed as a multi-level pixel matrix (38) in which one of a plurality of predetermined pixel values is assigned to each pixel and at least one of said predetermined pixel values is a conditional pixel value encoding a print instruction that depends upon whether or not a neighbouring pixel cannot be printed because of a defective print element,
 - b) determining defective print elements (22) of the printer, and
 - c) executing said print instruction.
2. The method of claim 1, wherein, in step (c), said conditional pixel value is interpreted as a pixel to be printed, when at least one of the neighbouring pixels corresponds to a defective print element, and is interpreted as a pixel not to be printed, otherwise.
 3. The method of claim 1, wherein the step (c) includes a post-processing step in which, for each pixel to which a conditional pixel value has been assigned, a pixel is printed in the same pixel position or a neighbouring pixel position with a likelihood that is determined by said conditional pixel value.
 4. The method of claim 3, wherein said post-processing step includes an error diffusion step.
 5. The method of claim 3 or 4, wherein said post-processing step is performed only for pixels in the neighbourhood of a pixel that corresponds to a defective print element.
 6. The method of claim 5, wherein, for a multi-pass print mode, the post-processing is limited to the pixel line (i) corresponding to a defective print element and to the pixel lines (i-1, i+1) directly above and below this line.
 7. The method of any of the preceding claims, wherein the step (a) includes a step of constructing said multi-level pixel matrix by assigning a high unconditional pixel value to each pixel that is to be printed pursuant to the original image information, and by incrementing the pixel values of other pixels that are directly adjacent to these pixels.
 8. The method of claim 7, wherein, for each pixel to which said high unconditional pixel value has been assigned, the pixel values of its neighbours are increased by equal increments.
 9. The method of claim 7, wherein, for a sequence of pixels to which said high unconditional pixel values have been assigned, an increment is added only to the pixel value of a selected one of the neighbours

of each pixel, and the selection of the neighbour, for which the pixel value is incremented, is varied successively.

10. A printer having a printhead (20) with a plurality of print elements (22), and a printhead controller (24) adapted to determine defective print elements (22) of the printer, **characterised in that** the printhead controller (24) is adapted to interpret a multi-level pixel matrix (38) that has been specified in step (a) of claim 1 and to execute a print instruction encoded in said pixel matrix, when the printer is employed in carrying out the method of any of the claims 1 to 9.
11. The printer of claim 10, comprising an image processor (26) adapted to carry out the step (a) of said method.
12. A computer program comprising computer program code to make a printer execute the method of any of the claims 1 to 9.

Patentansprüche

1. Verfahren zum Verschleiern von schadhafte Druckelementen (22) in einem Drucker, der einen Druckkopf (20) mit mehreren Druckelementen (22) aufweist, bei dem jedes Pixel (28) des Bildes einem Druckelement (22) zugewiesen wird, mit dem es gedruckt werden soll, und Bildinformation eines Pixels, das einem schadhafte Druckelement zugewiesen ist, auf eine nahegelegene Pixelposition verschoben wird, wo sie mit einem nicht schadhafte Druckelement gedruckt werden kann, **gekennzeichnet durch** die Schritte:
- a) Codieren der zu druckenden Bildinformation (30) als eine mehrwertige Pixelmatrix (38), bei der jedem Pixel einer von mehreren vorbestimmten Pixelwerten zugewiesen wird und wenigstens einer dieser vorbestimmten Pixelwerte ein konditionierter Pixelwert ist, der einen Druckbefehl codiert, der davon abhängig ist, ob ein benachbartes Pixel gedruckt werden kann oder wegen eines schadhafte Druckelementes nicht gedruckt werden kann,
- b) Bestimmen von schadhafte Druckelementen (22) des Druckers und
- c) Ausführen des Druckbefehls.
2. Verfahren nach Anspruch 1, bei dem in Schritt (c) der konditionierte Pixelwert als ein zu druckendes Pixel interpretiert wird, wenn wenigstens eines der benachbarten Pixel einem schadhafte Druckelement entspricht, und andernfalls als ein nicht zu druckendes Pixel interpretiert wird.

3. Verfahren nach Anspruch 1, bei dem der Schritt (c) einen Nachverarbeitungsschritt einschließt, in dem für jedes Pixel, dem ein konditionierter Pixelwert zugewiesen ist, ein Pixel mit einer Wahrscheinlichkeit, die durch den genannten konditionierten Pixelwert bestimmt ist, in derselben Pixelposition oder einer benachbarten Pixelposition gedruckt wird.
4. Verfahren nach Anspruch 3, bei dem der Nachverarbeitungsschritt einen Fehlerdiffusionsschritt einschließt.
5. Verfahren nach Anspruch 3 oder 4, bei dem der Nachverarbeitungsschritt nur für Pixel in der Nachbarschaft eines Pixels ausgeführt wird, das einem schadhafte Druckelement entspricht.
6. Verfahren nach Anspruch 5, bei dem, für einen multipass Druckmodus, die Nachverarbeitung beschränkt ist auf die Pixelzeile (i), die einem schadhafte Druckelement entspricht, und die Pixelzeilen (i-1, i+1) direkt über und unter dieser Zeile.
7. Verfahren nach einem der vorstehenden Ansprüche, bei dem der Schritt
- (a) einen Schritt der Konstruktion der genannten mehrwertigen Pixelmatrix einschließt, bei dem jedem Pixel, das gemäß der ursprünglichen Bildinformation gedruckt werden soll, ein hoher unkonditionierter Pixelwert zugewiesen wird und die Pixelwerte von anderen Pixeln, die diesen Pixeln direkt benachbart sind, erhöht werden.
8. Verfahren nach Anspruch 7, bei dem für jedes Pixel, dem der genannte hohe unkonditionierte Pixelwert zugewiesen worden ist, die Pixelwerte der Nachbarn um gleiche Inkremente erhöht werden.
9. Verfahren nach Anspruch 7, bei dem für eine Abfolge von Pixeln, denen der genannte hohe unkonditionierte Pixelwert zugewiesen worden ist, ein Inkrement nur zu dem Pixelwert eines ausgewählten Pixels unter den Nachbarn jedes Pixels addiert wird und die Auswahl des Nachbarn, für den der Pixelwert erhöht wird, fortlaufend variiert wird.
10. Drucker mit einem Druckkopf (20) mit mehreren Druckelementen (22), unter einer Druckkopf-Steuereinheit (24), die dazu eingerichtet ist, schadhafte Druckelemente (22) des Druckers zu erkennen, **dadurch gekennzeichnet, daß** die Druckkopf-Steuereinheit (24) dazu eingerichtet ist, eine mehrwertige Pixelmatrix (38) zu interpretieren, die in einem Schritt (a) nach Anspruch 1 spezifiziert worden ist, und einen in dieser Pixelmatrix codierten Druckbefehl auszuführen, wenn der Drucker bei der Ausführung des

Verfahrens nach einem der Ansprüche 1 bis 9 eingesetzt wird.

11. Drucker nach Anspruch 10, mit einem Bildprozessor (26), der dazu eingerichtet ist, den Schritt (a) dieses Verfahrens auszuführen.
12. Computerprogramm mit Computerprogrammcode, der einen Drucker das Verfahren nach einem der Ansprüche 1 bis 9 ausführen läßt.

Revendications

1. Procédé de camouflage d'éléments d'impression défectueux (22) dans une imprimante comprenant une tête d'impression (20) ayant une pluralité d'éléments d'impression (22), où chaque pixel (28) de l'image est attribué à un élément d'impression (22) avec lequel il doit être imprimé et l'information d'image d'un pixel attribué à un élément d'impression défectueux est déplacée jusqu'à un emplacement de pixel proche où elle peut être imprimée par un élément d'impression non défectueux, le procédé étant **caractérisé par** les étapes consistant à :

- a) coder l'information d'image (30) à imprimer sous la forme d'une matrice de pixels multi-niveau (38) dans laquelle l'une d'une pluralité de valeurs de pixels prédéterminées est attribuée à chaque pixel et au moins l'une desdites valeurs de pixels prédéterminées est une valeur de pixel conditionnelle codant une instruction d'impression qui dépend si oui ou non un pixel voisin peut être imprimé à cause d'un élément d'impression défectueux,
- b) déterminer les éléments d'impression défectueux (22) de l'imprimante, et
- c) exécuter ladite instruction d'impression.

2. Procédé selon la revendication 1, dans lequel dans l'étape (c), ladite valeur de pixel conditionnelle est interprétée comme un pixel à imprimer, lorsqu'au moins l'un des pixels voisins correspond à un élément d'impression défectueux et est interprétée comme un pixel ne devant pas être imprimé, dans le cas contraire.
3. Procédé selon la revendication 1, dans lequel l'étape (c) comprend une étape de post-traitement dans laquelle, pour chaque pixel auquel une valeur de pixel conditionnelle a été attribuée, un pixel est imprimé dans le même emplacement de pixel ou dans un emplacement de pixel proche avec une probabilité déterminée par ladite valeur de pixel conditionnelle.
4. Procédé selon la revendication 3, dans lequel ladite étape de post-traitement comprend une étape de dif-

fusion d'erreur.

5. Procédé selon la revendication 3 ou 4, dans lequel ladite étape de post-traitement est mise en oeuvre uniquement pour les pixels se trouvant à proximité d'un pixel correspondant à un élément d'impression défectueux.
6. Procédé selon la revendication 5, dans lequel, pour un mode d'impression multipassage, le post-traitement est limité à la ligne de pixels (i) correspondant à un élément d'impression défectueux et aux lignes de pixels (i-1, i+1) situées directement au-dessus et en dessous de cette ligne.
7. Procédé selon l'une quelconque des revendications précédentes, dans lequel l'étape (a) comprend une étape de construction de ladite matrice de pixels multi-niveau en attribuant une valeur de pixel inconditionnelle élevée à chaque pixel devant être imprimé en fonction de l'information d'image originale et en incrémentant les valeurs de pixels des autres pixels qui sont directement adjacents à ces pixels.
8. Procédé selon la revendication 7, dans lequel, pour chaque pixel auquel ladite valeur de pixel inconditionnelle élevée a été attribuée, les valeurs de pixels de ses voisins sont augmentées d'incrémentaux égaux.
9. Procédé selon la revendication 7, dans lequel, pour une série de pixels auxquels lesdites valeurs de pixels inconditionnelles élevées ont été attribuées, on ajoute un incrément uniquement à la valeur de pixel d'un pixel sélectionné parmi les voisins de chaque pixel et le choix du pixel voisin, pour lequel la valeur de pixel est incrémentée, varie successivement.
10. Imprimante comprenant une tête d'impression (20) ayant une pluralité d'éléments d'impression (22) et un contrôleur (24) de la tête d'impression conçu pour déterminer les éléments d'impression défectueux (22) de l'imprimante, **caractérisé en ce que** le contrôleur (24) de la tête d'impression est conçu pour interpréter une matrice de pixels multi-niveau (38) spécifiée dans l'étape (a) de la revendication 1 et pour exécuter une instruction d'impression codée dans ladite matrice de pixels, lorsque l'imprimante est utilisée pour mettre en oeuvre le procédé selon l'une quelconque des revendications 1 à 9.
11. Imprimante selon la revendication 10, comprenant une machine de traitement d'image (26) conçue pour mettre en oeuvre l'étape (a) dudit procédé.
12. Programme informatique comprenant un code programme informatique permettant à une imprimante

d'exécuter le procédé de l'une quelconque des revendications 1 à 9.

5

10

15

20

25

30

35

40

45

50

55

Fig. 1

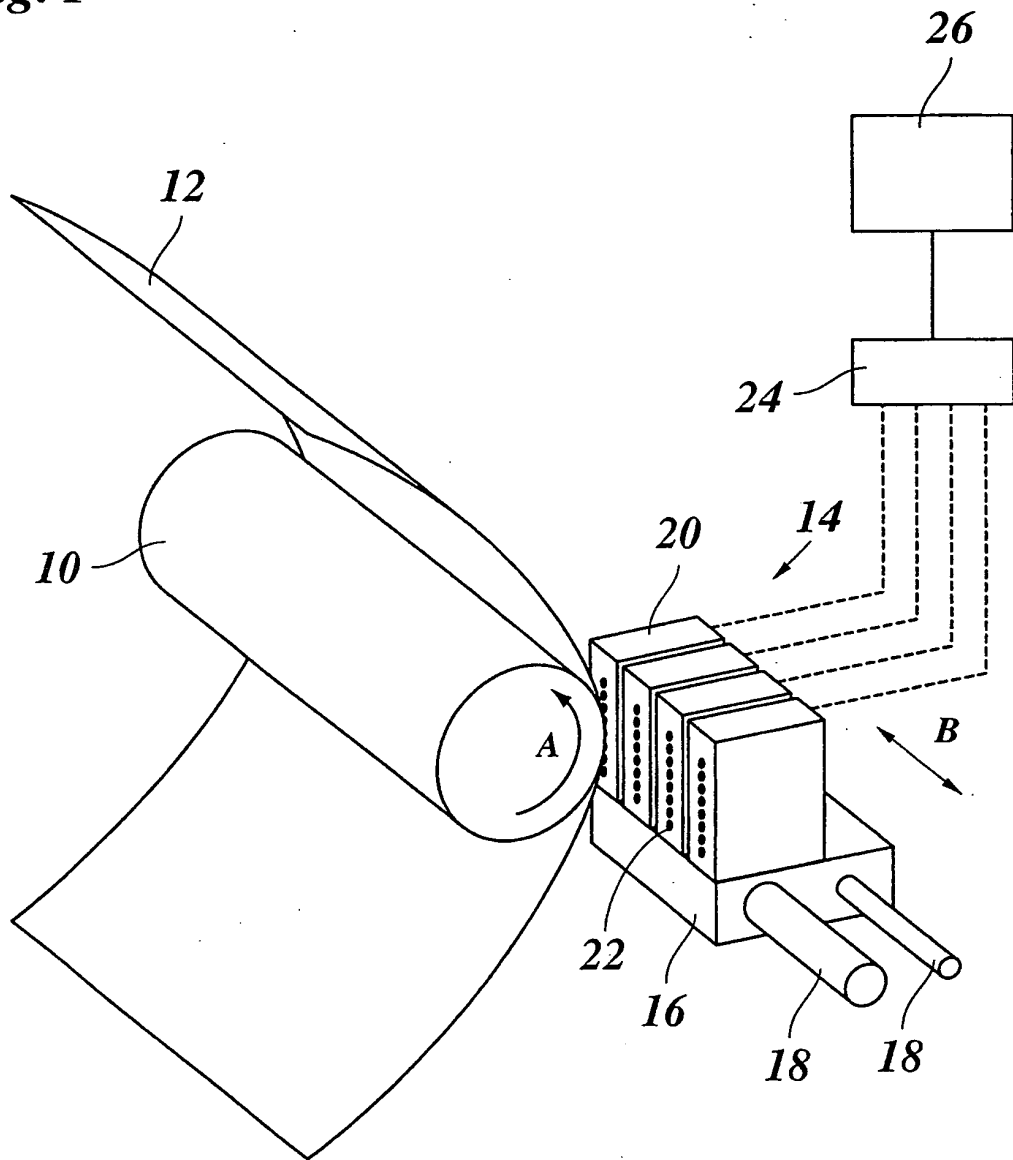

Fig. 2A

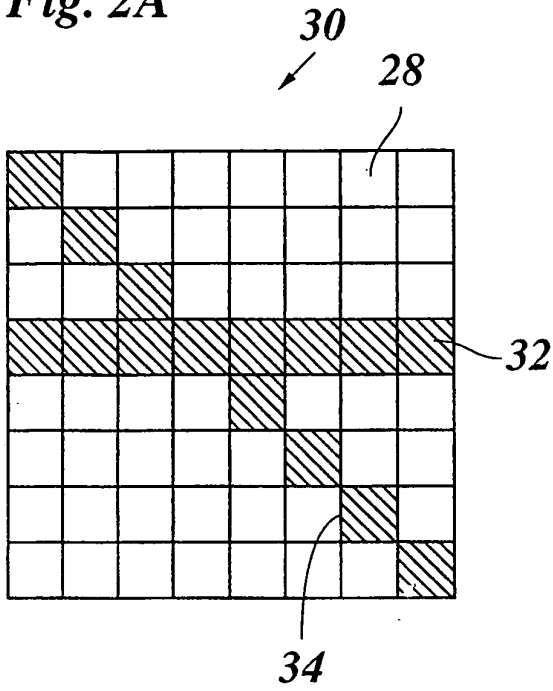

Fig. 2B

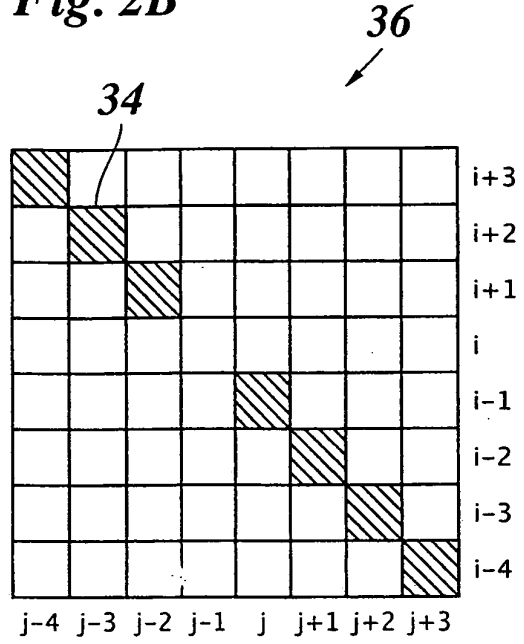

Fig. 2C

2	0	0	0	0	0	0	0	i+3
1	2	0	0	0	0	0	0	i+2
0	1	2	0	0	0	0	0	i+1
2	2	2	2	2	2	2	2	i
1	1	1	1	2	1	1	1	i-1
0	0	0	0	1	2	0	0	i-2
0	0	0	0	0	1	2	0	i-3
0	0	0	0	0	0	1	2	i-4
j-4	j-3	j-2	j-1	j	j+1	j+2	j+3	

Fig. 2D

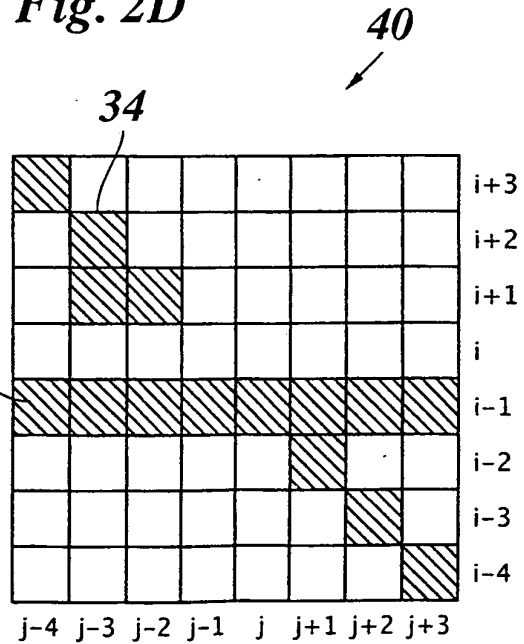

Fig. 3A

30
↙

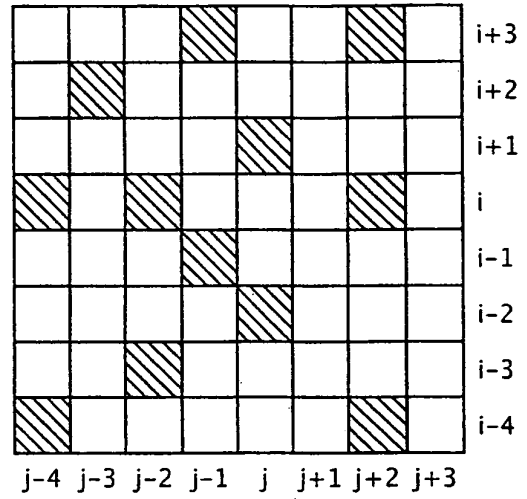

Fig. 3B

38
↙

0	0	0	2↓	0	0	2↑	0	i+3
0	2↓	0	1	1	0	0	0	i+2
0	1	1	0	2↑	0	0	0	i+1
2↓	0	2↑	1	0	0	2↓	0	i
1	0	0	2↑	0	0	1	0	i-1
0	0	1	0	2↓	0	0	0	i-2
0	0	2↑	0	1	0	1	0	i-3
2↓	0	0	0	0	0	2↑	0	i-4
j-4	j-3	j-2	j-1	j	j+1	j+2	j+3	

Fig. 3C

40
↙

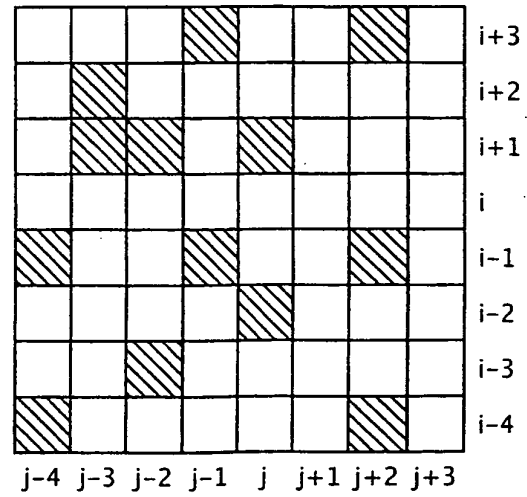

Fig. 4A

30
↙

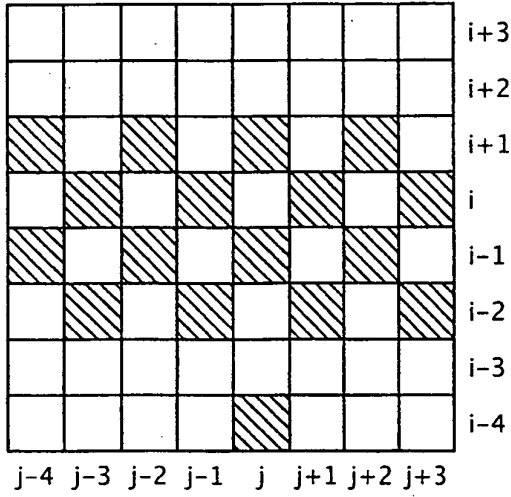

Fig. 4B

36
↙

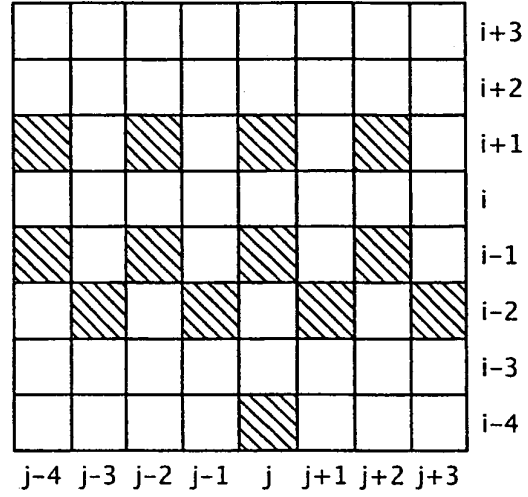

Fig. 4C

38
↙

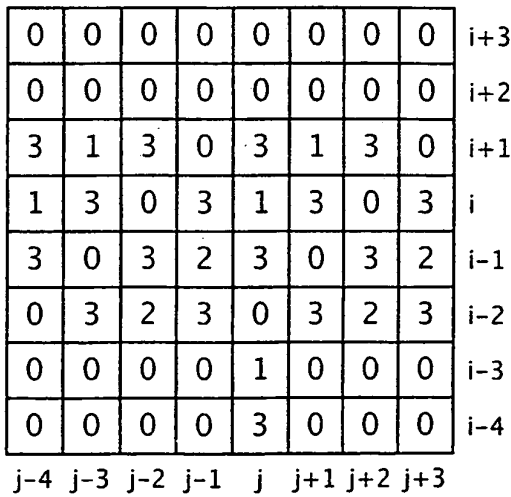

Fig. 4D

40
↙

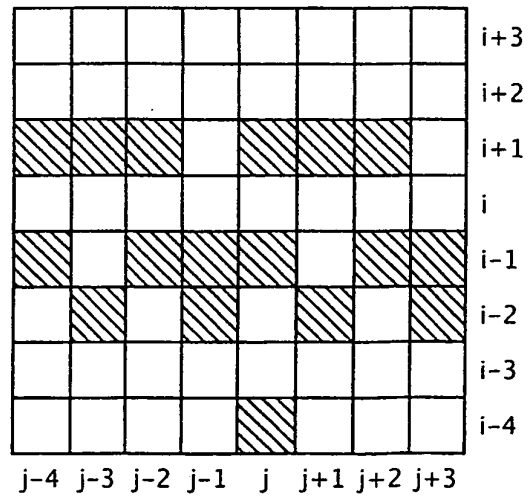

Fig. 5A

30

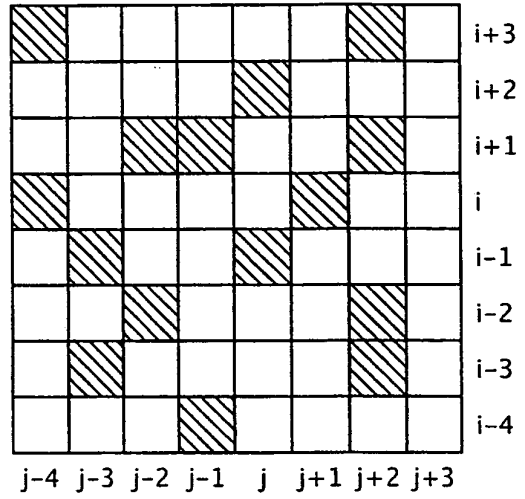

Fig. 5B

38

2	0	0	0	1	0	2	0	i+3
1	0	1	1	2	0	1	0	i+2
1	0	2	2	1	1	2	0	i+1
2	1	1	1	1	2	1	0	i
1	2	1	0	2	1	1	0	i-1
0	1	2	0	1	0	2	0	i-2
1	2	1	1	0	0	2	0	i-3
0	1	0	2	0	0	1	0	i-4
j-4	j-3	j-2	j-1	j	j+1	j+2	j+3	

Fig. 5C

40

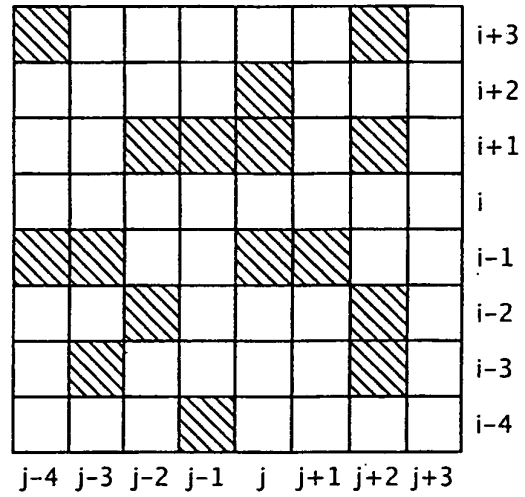

Fig. 6A

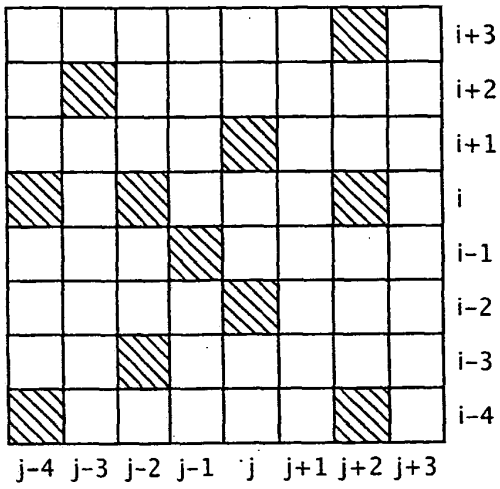

Fig. 6B

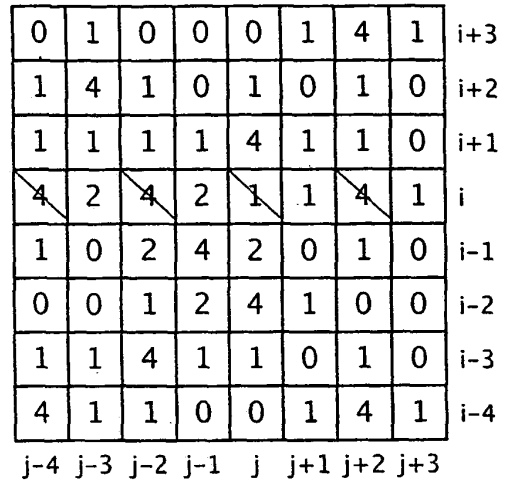

Fig. 6C

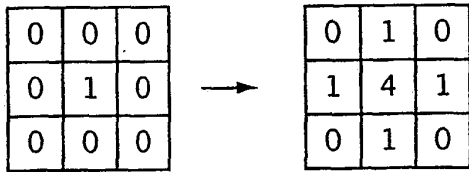

Fig. 6D

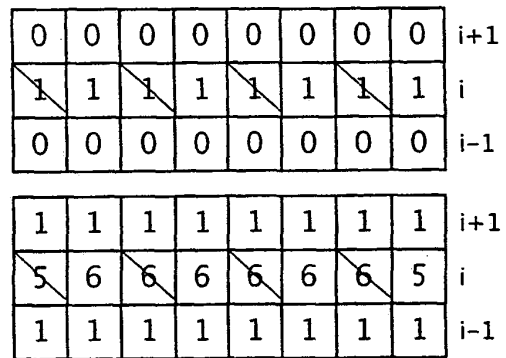

Fig. 7A

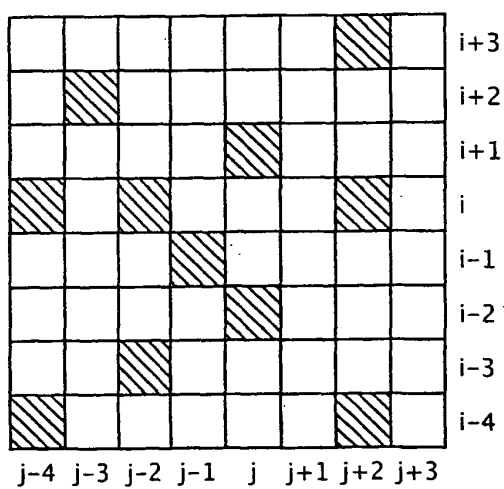

Fig. 7B

