

(12) INTERNATIONAL APPLICATION PUBLISHED UNDER THE PATENT COOPERATION TREATY (PCT)

(19) World Intellectual Property Organization
International Bureau



(43) International Publication Date
26 November 2009 (26.11.2009)

PCT

(10) International Publication Number
WO 2009/142547 A2

- (51) **International Patent Classification:**
H05H 13/04 (2006.01) *H05H 7/10* (2006.01)
H05H 7/04 (2006.01) *H05H 7/12* (2006.01)
H05H 7/08 (2006.01)
- (21) **International Application Number:** PCT/RU2009/000249
- (22) **International Filing Date:** 21 May 2009 (21.05.2009)
- (25) **Filing Language:** English
- (26) **Publication Language:** English
- (30) **Priority Data:**
- | | | |
|------------|--------------------------------|----|
| 61/055,395 | 22 May 2008 (22.05.2008) | US |
| 61/055,409 | 22 May 2008 (22.05.2008) | US |
| 61/134,717 | 14 July 2008 (14.07.2008) | US |
| 61/134,707 | 14 July 2008 (14.07.2008) | US |
| 61/134,718 | 14 July 2008 (14.07.2008) | US |
| 61/137,574 | 1 August 2008 (01.08.2008) | US |
| 61/188,406 | 11 August 2008 (11.08.2008) | US |
| 61/188,407 | 11 August 2008 (11.08.2008) | US |
| 61/189,017 | 15 August 2008 (15.08.2008) | US |
| 61/189,815 | 25 August 2008 (25.08.2008) | US |
| 61/190,546 | 2 September 2008 (02.09.2008) | US |
| 61/190,613 | 2 September 2008 (02.09.2008) | US |
| 61/191,043 | 8 September 2008 (08.09.2008) | US |
| 61/192,245 | 17 September 2008 (17.09.2008) | US |
| 61/192,237 | 17 September 2008 (17.09.2008) | US |
| 61/197,971 | 3 November 2008 (03.11.2008) | US |
| 61/198,248 | 5 November 2008 (05.11.2008) | US |
| 61/198,508 | 7 November 2008 (07.11.2008) | US |
| 61/198,509 | 7 November 2008 (07.11.2008) | US |
| 61/199,405 | 17 November 2008 (17.11.2008) | US |
| 61/199,403 | 17 November 2008 (17.11.2008) | US |
| 61/199,404 | 17 November 2008 (17.11.2008) | US |
| 61/201,728 | 15 December 2008 (15.12.2008) | US |
| 61/201,732 | 15 December 2008 (15.12.2008) | US |
| 61/201,731 | 15 December 2008 (15.12.2008) | US |
| 61/203,308 | 22 December 2008 (22.12.2008) | US |
| 61/205,362 | 21 January 2009 (21.01.2009) | US |
- (71) **Applicant and**
(72) **Inventor:** BALAKIN, Vladimir Yegorovich [RU/RU];
Moskovskaya Street, 3-23, Protvino, Moscow region,
142281 (RU).
- (74) **Agents:** LAW FIRM "GORODISSKY &
PARTNERS" LTD. et al.; MITS Alexander
Vladimirovich, B. Spasskaya str., 25, bldg. 3, Moscow,
129090 (RU).
- (81) **Designated States** (*unless otherwise indicated, for every kind of national protection available*): AE, AG, AL, AM, AO, AT, AU, AZ, BA, BB, BG, BH, BR, BW, BY, BZ, CA, CH, CN, CO, CR, CU, CZ, DE, DK, DM, DO, DZ, EC, EE, EG, ES, FI, GB, GD, GE, GH, GM, GT, HN, HR, HU, ID, IL, IN, IS, JP, KE, KG, KM, KN, KP, KR, KZ, LA, LC, LK, LR, LS, LT, LU, LY, MA, MD, ME, MG, MK, MN, MW, MX, MY, MZ, NA, NG, NI, NO, NZ, OM, PG, PH, PL, PT, RO, RS, RU, SC, SD, SE, SG, SK, SL, SM, ST, SV, SY, TJ, TM, TN, TR, TT, TZ, UA, UG, US, UZ, VC, VN, ZA, ZM, ZW.
- (84) **Designated States** (*unless otherwise indicated, for every kind of regional protection available*): ARIPO (BW, GH, GM, KE, LS, MW, MZ, NA, SD, SL, SZ, TZ, UG, ZM, ZW), Eurasian (AM, AZ, BY, KG, KZ, MD, RU, TJ, TM), European (AT, BE, BG, CH, CY, CZ, DE, DK, EE, ES, FI, FR, GB, GR, HR, HU, IE, IS, IT, LT, LU, LV, MC, MK, MT, NL, NO, PL, PT, RO, SE, SI, SK, TR), OAPI (BF, BJ, CF, CG, CI, CM, GA, GN, GQ, GW, ML, MR, NE, SN, TD, TG).
- Published:**
— *without international search report and to be republished upon receipt of that report (Rule 48.2(g))*

(54) **Title:** CHARGED PARTICLE BEAM ACCELERATION METHOD AND APPARATUS AS PART OF A CHARGED PARTICLE CANCER THERAPY SYSTEM

(57) **Abstract:** The invention comprises a charged particle beam acceleration method and apparatus used as part of multi-axis charged particle radiation therapy of cancerous tumors. The accelerator includes a synchrotron having advances in turning magnets, edge focusing magnets, magnetic field concentration magnets, and extraction and intensity control elements that minimize the overall size of the synchrotron, provide a tightly controlled proton beam, directly reduce the size of required magnetic fields, directly reduces required operating power, and allows independent energy and intensity control of extracted charged particles from the synchrotron.



WO 2009/142547 A2

**CHARGED PARTICLE BEAM ACCELERATION METHOD AND APPARATUS
AS PART OF A CHARGED PARTICLE CANCER THERAPY SYSTEM**

CROSS REFERENCES TO RELATED APPLICATIONS

This application claims benefit of:

- U.S. provisional patent application no. 61/055,395 filed May 22, 2008;
- U.S. provisional patent application no. 61/137,574 filed August 1, 2008;
- U.S. provisional patent application no. 61/192,245 filed September 17, 2008;
- U.S. provisional patent application no. 61/055,409 filed May 22, 2008;
- U.S. provisional patent application no. 61/203,308 filed December 22, 2008;
- U.S. provisional patent application no. 61/188,407 filed August 11, 2008;
- U.S. provisional patent application no. 61/???,??? filed March 2009 (attorney docket no. PROT0005PR);
- U.S. provisional patent application no. 61/188,406 filed August 11, 2008;
- U.S. provisional patent application no. 61/189,815 filed August 25, 2008;
- U.S. provisional patent application no. 61/208,182 filed February 23, 2009 (attorney docket no. PROT0009PR);
- U.S. provisional patent application no. 61/201,731 filed December 15, 2008 (attorney docket no PROT0010PR);
- U.S. provisional patent application no. 61/???,??? filed March, 2009 (attorney docket no. PROT0011PR);
- U.S. provisional patent application no. 61/205,362 filed January 12, 2009;
- U.S. provisional patent application no. 61/134,717 filed July 14, 2008;

U.S. provisional patent application no. 61/134,707 filed July 14, 2008;

U.S. provisional patent application no. 61/201,732 filed December 15, 2008;

U.S. provisional patent application no. 61/198,509 filed November 7, 2008;

U.S. provisional patent application no. 61/134,718 filed July 14, 2008;

U.S. provisional patent application no. 61/190,613 filed September 2, 2008;

U.S. provisional patent application no. 61/191,043 filed September 8, 2008;

U.S. provisional patent application no. 61/192,237 filed September 17, 2008;

U.S. provisional patent application no. 61/201,728 filed December 15, 2008;

U.S. provisional patent application no. 61/190,546 filed September 2, 2008;

U.S. provisional patent application no. 61/189,017 filed August 15, 2008;

U.S. provisional patent application no. 61/198,248 filed November 5, 2008;

U.S. provisional patent application no. 61/198,508 filed November 7, 2008;

U.S. provisional patent application no. 61/197,971 filed November 3, 2008;

U.S. provisional patent application no. 61/199,405 filed November 17, 2008;

U.S. provisional patent application no. 61/199,403 filed November 17, 2008; and

U.S. provisional patent application no. 61/199,404 filed November 17, 2008; and

claims priority to PCT patent application no. PCT/RU2009/00015, "Multi-Field Charged Particle Cancer Therapy Method and Apparatus", filed March 4, 2009 (attorney docket no. ZPRO0001P);

all of which are incorporated herein in their entirety by this reference thereto.

BACKGROUND OF THE INVENTION

FIELD OF THE INVENTION

This invention relates generally to treatment of solid cancers. More particularly, the invention relates to an ion beam acceleration system, which is used in conjunction with charged particle cancer therapy beam injection, extraction, and/or targeting methods and apparatus.

DISCUSSION OF THE PRIOR ART

Cancer Treatment

Proton therapy systems typically include: a beam generator, an accelerator, and a beam transport system to move the resulting accelerated protons to a treatment room where the protons are delivered to a tumor in a patient's body.

Proton therapy works by aiming energetic ionizing particles, such as protons accelerated with a particle accelerator, onto a target tumor. These particles damage the DNA of cells, ultimately causing their death. Cancerous cells, because of their high rate of division and their reduced ability to repair damaged DNA, are particularly vulnerable to attacks on their DNA.

Due to their relatively enormous size, protons scatter less easily in the tissue and there is very little lateral dispersion. Hence, the proton beam stays focused on the tumor shape without much lateral damage to surrounding tissue. All protons of a given energy have a certain range, defined by the Bragg peak, and the dosage delivery to tissue ratio is at a maximum over just the last few millimeters of the particle's range. The penetration depth depends on the energy of the particles, which is directly related to the speed to which the particles were accelerated by the proton accelerator. The speed of the proton is adjustable to the maximum rating of the accelerator. It is therefore possible to focus the cell damage due to the proton beam at the very depth in the tissues where the tumor is situated. Tissues situated before the Bragg peak receive some reduced dose and tissues situated after the peak receive none.

Synchrotron

K. Hiramoto, *et. al.* "Accelerator System", U.S. patent no. 4,870,287 (September 26, 1989) describes an accelerator system having a selector electromagnet for introducing an ion beam accelerated by pre-accelerators into either a radioisotope producing unit or a synchrotron.

K. Hiramoto, *et. al.* "Circular Accelerator, Method of Injection of Charged Particle Thereof, and Apparatus for Injection of Charged Particle Thereof", U.S. patent no. 5,789,875 (August 4, 1998) and K. Hiramoto, *et. al.* "Circular Accelerator, Method of Injection of Charged Particle Thereof, and Apparatus for Injection of Charged Particle Thereof", U.S. patent no. 5,600,213 (February 4, 1997) both describe a method and apparatus for injecting a large number of charged particles into a vacuum duct where the beam of injection has a height and width relative to a geometrical center of the duct.

Accelerator / Synchrotron

S. Peggs, *et. al.* "Rapid Cycling Medical Synchrotron and Beam Delivery System", U.S. patent no. 7,432,516 (October 7, 2008) describe a synchrotron having combined function magnets and a radio frequency (RF) cavity accelerator. The combined function magnets function to first bend the particle beam along an orbital path and second focus the particle beam. The RF cavity accelerator is a ferrite loaded cavity adapted for high speed frequency swings for rapid cycling particle acceleration.

H. Tanaka, *et. al.* "Charged Particle Accelerator", U.S. patent no. 7,259,529 (August 21, 2007) describe a charged particle accelerator having a two period acceleration process with a fixed magnetic field applied in the first period and a timed second acceleration period to provide compact and high power acceleration of the charged particles.

T. Haberer, *et. al.* "Ion Beam Therapy System and a Method for Operating the System", U.S. patent no. 6,683,318 (January 27, 2004) describe an ion beam therapy system and method for operating the system. The ion beam system uses a gantry that has a vertical deflection system and a horizontal deflection system positioned before a last bending magnet that result in a parallel scanning mode resulting from an edge focusing effect.

V. Kulish, *et. al.* "Inductional Undulative EH-Accelerator", U.S. patent no. 6,433,494 (August 13, 2002) describe an inductive undulative EH-accelerator for acceleration of beams of charged particles. The device consists of an electromagnet undulation system, whose driving system for electromagnets is made in the form of a radio-frequency (RF) oscillator operating in the frequency range from about 100 KHz to 10 GHz.

K. Saito, *et. al.* "Radio-Frequency Accelerating System and Ring Type Accelerator Provided with the Same", U.S. patent no. 5,917,293 (June 29, 1999) describe a radio-frequency accelerating system having a loop antenna coupled to a magnetic core group and impedance adjusting means connected to the loop antenna. A relatively low voltage is applied to the impedance adjusting means allowing small construction of the adjusting means.

J. Hirota, *et. al.* "Ion Beam Accelerating Device Having Separately Excited Magnetic Cores", U.S. patent no. 5,661,366 (August 26, 1997) describe an ion beam accelerating device having a plurality of high frequency magnetic field inducing units and magnetic cores.

J. Hirota, *et. al.* "Acceleration Device for Charged Particles", U.S. patent no. 5,168,241 (December 1, 1992) describe an acceleration cavity having a high frequency power source and a looped conductor operating under a control that combine to control a coupling constant and/or de-tuning allowing transmission of power more efficiently to the particles.

Magnet Shape

M. Tadokoro, *et. al.* "Electromagnetic and Magnetic Field Generating Apparatus", U.S. patent no. 6,365,894 (April 2, 2002) and M. Tadokoro, *et. al.* "Electromagnetic and Magnetic Field Generating Apparatus", U.S. patent no. 6,236,043 (May 22, 2001) each describe a pair of magnetic poles, a return yoke, and exciting coils. The interior of the magnetic poles each have a plurality of air gap spacers to increase magnetic field strength.

Respiration

K. Matsuda "Radioactive Beam Irradiation Method and Apparatus Taking Movement of the Irradiation Area Into Consideration", U.S. patent no. 5,538,494 (July 23, 1996) describes a method and apparatus that enables irradiation even in the case of a diseased part changing position due to physical activity, such as breathing and heart beat. Initially, a position change of a diseased body part and physical activity of the patient are measured concurrently and a relationship therebetween is defined as a function. Radiation therapy is performed in accordance to the function.

Patient Positioning

Y. Nagamine, *et. al.* "Patient Positioning Device and Patient Positioning Method", U.S. patent no. 7,212,609 (May 1, 2007) and Y. Nagamine, *et. al.* "Patient Positioning Device and Patient Positioning Method", U.S. patent no. 7,212,608 (May 1, 2007) describe a patient positioning system that compares a comparison area of a reference X-ray image and a current X-ray image of a current patient location using pattern matching.

D. Miller, *et. al.* "Modular Patient Support System", U.S. patent no. 7,173,265 (February 6, 2007) describe a radiation treatment system having a patient support system that includes a modularly expandable patient pod and at least one immobilization device, such as a moldable foam cradle.

K. Kato, *et. al.* "Multi-Leaf Collimator and Medical System Including Accelerator", U.S. patent no. 6,931,100 (August 16, 2005); K. Kato, *et. al.* "Multi-Leaf Collimator and Medical System Including Accelerator", U.S. patent no. 6,823,045 (November 23, 2004); K. Kato, *et. al.* "Multi-Leaf Collimator and Medical System Including Accelerator", U.S. patent no. 6,819,743 (November 16, 2004); and K. Kato, *et. al.* "Multi-Leaf Collimator and Medical System Including Accelerator", U.S. patent no. 6,792,078 (September 14, 2004) all describe a system of leaf

plates used to shorten positioning time of a patient for irradiation therapy. Motor driving force is transmitted to a plurality of leaf plates at the same time through a pinion gear. The system also uses upper and lower air cylinders and upper and lower guides to position a patient.

Computer Control

A. Belousov *et. al.* "Configuration Management and Retrieval System for Proton Beam Therapy System", U.S. patent no. 7,368,740 (May 6, 2008); A. Belousov *et. al.* "Configuration Management and Retrieval System for Proton Beam Therapy System", U.S. patent no. 7,084,410 (August 1, 2006); and A. Belousov *et. al.* "Configuration Management and Retrieval System for Proton Beam Therapy System", U.S. patent no. 6,822,244 (November 23, 2004) all describe a multi-processor software controlled proton beam system having treatment configurable parameters that are easily modified by an authorized user to prepare the software controlled system for various modes of operation to insure that data and configuration parameters are accessible if single point failures occur in the database.

J. Hirota *et. al.* "Automatically Operated Accelerator Using Obtained Operating Patterns", U.S. patent no. 5,698,954 (December 16, 1997) describes a main controller for determining the quantity of control and the control timing of every component of an accelerator body with the controls coming from an operating pattern.

Problem

There exists in the art of particle beam therapy of cancerous tumors a need for efficiently accelerating a charged particle beam in a synchrotron. Further, there exists in the art a need for efficiently generating a negative ion, extracting the negative ion, converting the negative ion into a positive ion, and injecting the

positive ion into a synchrotron. Still further, there exists a need in the art to control the charged particle cancer therapy system in terms of specified energy, intensity, and/or timing of charged particle delivery. Yet still further, there exists a need for efficient, precise, and/or accurate noninvasive, *in-vivo* treatment of a solid cancerous tumor with minimization of damage to surrounding healthy tissue in a patient.

SUMMARY OF THE INVENTION

The invention comprises a particle beam accelerator, which is part of a charged particle cancer therapy beam system.

DESCRIPTION OF THE FIGURES

Figure 1 illustrates component connections of a particle beam therapy system;

Figure 2 illustrates a charged particle therapy system;

Figure 3 illustrates an ion beam generation system;

Figure 4 illustrates a negative ion beam source;

Figure 5 illustrates an ion beam focusing system;

Figures 6 A-D illustrate electrodes about a negative ion beam path;

Figure 7A illustrates a tandem accelerator having a foil, 7B illustrates a support structure, and 7C illustrates a conversion foil;

Figure 8 is a synchrotron control flowchart;

Figure 9 illustrates straight and turning sections of a synchrotron;

Figure 10 illustrates bending magnets of a synchrotron;

Figure 11 provides a perspective view of a bending magnet;

Figure 12 illustrates a cross-sectional view of a bending magnet;

Figure 13 illustrates a cross-sectional view of a bending magnet;

Figure 14 illustrates magnetic field concentration in a bending magnet;

Figure 15 illustrates correction coils in a bending magnet;

Figure 16 illustrates a magnetic turning section of a synchrotron;

Figure 17 illustrates a magnetic field control system;

Figure 18 illustrates a charged particle extraction and intensity control system;

Figure 19 illustrates a patient positioning system from: (A) a front view and (B) a top view; and

Figure 20 illustrates multi-dimensional scanning of a charged particle beam spot scanning system operating on: (A) a 2-D slice or (B) a 3-D volume of a tumor.

DETAILED DESCRIPTION OF THE INVENTION

The invention relates generally to treatment of solid cancers. More particularly, the invention relates to a method and apparatus for accelerating a charged particle beam in a synchrotron.

In one embodiment, synchrotron advancements are described resulting in a small footprint accelerator. Particularly, turning magnets, edge focusing magnets, magnetic field concentration magnets, and extraction elements are described that minimize the overall size of the synchrotron, provide a tightly controlled proton beam, directly reduce the size of required magnetic fields, directly reduces required operating power, and allow continual acceleration of protons in a synchrotron even during a process of extracting protons from the synchrotron. In various examples of the system described herein, the synchrotron has:

- multiple turning magnets with focusing geometries;
- at least 4 and preferably 6, 8, 10 or more edge focusing edges per 90 degrees of turn of the charged particle beam in a synchrotron having four turning sections;
- at least about 16 and preferably about 24, 32, or more edge focusing edges per orbit of the charged particle beam in the synchrotron;

- only 4 turning sections where each of the turning sections includes at least 4 and preferably 8 edge focusing edges;
- an equal number of straight sections and turning sections;
- exactly 4 turning sections;
- no quadrupoles in the circulating path of the synchrotron;
- independent energy and intensity control of an extracted charged particle beam;
- a circumference of less than 60 meters;
- a circumference of less than 60 meters and 32 edge focusing surfaces; and/or
- any of about 8, 16, 24, or 32 non-quadrupole magnets per circulating path of the synchrotron, where the non-quadrupole magnets include edge focusing edges.

The optional ion beam injection system preferably includes several components, including a negative ion source, an ion beam focusing system, a two part vacuum system, and a tandem accelerator. The negative ion source preferably includes an inlet port for injection of hydrogen gas into a high temperature plasma chamber, a magnetic material, which provides a magnetic field barrier between the high temperature plasma chamber and a low temperature plasma region on the opposite side of the magnetic field barrier. An extraction pulse is applied to a negative ion extraction electrode to pull the negative ion beam into a negative ion beam path, which proceeds through a first partial vacuum system, through an ion beam focusing system, into the tandem accelerator, and into a synchrotron after conversion to a proton beam at a converting foil.

In yet another embodiment, the ion beam source system and synchrotron are preferably computer integrated with a patient interface module including

respiration monitoring sensors to synchronize charged particle delivery with a set period of a patient's respiration cycle.

Cyclotron / Synchrotron

A cyclotron uses a constant magnetic field and a constant-frequency applied electric field. One of the two fields is varied in a synchrocyclotron. Both of these fields are varied in a synchrotron. Thus, a synchrotron is a particular type of cyclic particle accelerator in which a magnetic field is used to turn the particles so they circulate and an electric field is used to accelerate the particles. The synchrotron carefully synchronizes the applied fields with the travelling particle beam.

By increasing the fields appropriately as the particles gain energy, the charged particles path can be held constant as they are accelerated. This allows the vacuum container for the particles to be a large thin torus. In reality it is easier to use some straight sections between the bending magnets and some turning sections giving the torus the shape of a round-cornered polygon. A path of large effective radius is thus constructed using simple straight and curved pipe segments, unlike the disc-shaped chamber of the cyclotron type devices. The shape also allows and requires the use of multiple magnets to bend the particle beam.

The maximum energy that a cyclic accelerator can impart is typically limited by the strength of the magnetic fields and the minimum radius / maximum curvature, of the particle path. In a cyclotron the maximum radius is quite limited as the particles start at the center and spiral outward, thus this entire path must be a self-supporting disc-shaped evacuated chamber. Since the radius is limited, the power of the machine becomes limited by the strength of the magnetic field. In the case of an ordinary electromagnet, the field strength is limited by the

saturation of the core because when all magnetic domains are aligned the field may not be further increased to any practical extent. The arrangement of the single pair of magnets also limits the economic size of the device.

Synchrotrons overcome these limitations, using a narrow beam pipe surrounded by much smaller and more tightly focusing magnets. The ability of this device to accelerate particles is limited by the fact that the particles must be charged to be accelerated at all, but charged particles under acceleration emit photons, thereby losing energy. The limiting beam energy is reached when the energy lost to the lateral acceleration required to maintain the beam path in a circle equals the energy added each cycle. More powerful accelerators are built by using large radius paths and by using more numerous and more powerful microwave cavities to accelerate the particle beam between corners. Lighter particles, such as electrons, lose a larger fraction of their energy when turning. Practically speaking, the energy of electron/positron accelerators is limited by this radiation loss, while it does not play a significant role in the dynamics of proton or ion accelerators. The energy of those is limited strictly by the strength of magnets and by the cost.

CHARGED PARTICLE BEAM THERAPY

Throughout this document, a charged particle beam therapy system, such as a proton beam, hydrogen ion beam, or carbon ion beam, is described. Herein, the charged particle beam therapy system is described using a proton beam. However, the aspects taught and described in terms of a proton beam are not intended to be limiting to that of a proton beam and are illustrative of a charged particle beam system. Any charged particle beam system is equally applicable to the techniques described herein.

Referring now to Figure 1, a charged particle beam system 100 is illustrated. The charged particle beam preferably comprises a number of subsystems including any of: a main controller 110; an injection system 120; a synchrotron 130 that typically includes: (1) an accelerator system 132 and (2) an extraction system 134; a scanning / targeting / delivery system 140; a patient interface module 150; a display system 160; and/or an imaging system 170.

In one embodiment, one or more of the subsystems are stored on a client. The client is a computing platform configured to act as a client device, *e.g.* a personal computer, a digital media player, a personal digital assistant, *etc.* The client comprises a processor that is coupled to a number of external or internal inputting devices, *e.g.* a mouse, a keyboard, a display device, *etc.* The processor is also coupled to an output device, *e.g.* a computer monitor to display information. In one embodiment, the main controller 110 is the processor. In another embodiment, the main controller 110 is a set of instructions stored in memory that is carried out by the processor.

The client includes a computer-readable storage medium, *i.e.* memory. The memory includes, but is not limited to, an electronic, optical, magnetic, or another storage or transmission device capable of coupling to a processor, *e.g.* such as a processor in communication with a touch-sensitive input device, with computer-readable instructions. Other examples of suitable media include, for example, flash drive, CD-ROM, read only memory (ROM), random access memory (RAM), application-specific integrated circuit (ASIC), DVD, magnetic disk, memory chip, *etc.* The processor executes a set of computer-executable program code instructions stored in the memory. The instructions may comprise code from any computer-programming language, including, for example, C, C++, C#, Visual Basic, Java, and JavaScript.

An exemplary method of use of the charged particle beam system 100 is provided. The main controller 110 controls one or more of the subsystems to accurately and precisely deliver protons to a tumor of a patient. For example, the main controller 110 obtains an image, such as a portion of a body and/or of a tumor, from the imaging system 170. The main controller 110 also obtains position and/or timing information from the patient interface module 150. The main controller 110 then optionally controls the injection system 120 to inject a proton into a synchrotron 130. The synchrotron typically contains at least an accelerator system 132 and an extraction system 134. The main controller preferably controls the proton beam within the accelerator system, such as by controlling speed, trajectory, and timing of the proton beam. The main controller then controls extraction of a proton beam from the accelerator through the extraction system 134. For example, the controller controls timing, energy, and/or intensity of the extracted beam. The controller 110 also preferably controls targeting of the proton beam through the scanning / targeting / delivery system 140 to the patient interface module 150. One or more components of the patient interface module 150 are preferably controlled by the main controller 110. Further, display elements of the display system 160 are preferably controlled via the main controller 110. Displays, such as display screens, are typically provided to one or more operators and/or to one or more patients. In one embodiment, the main controller 110 times the delivery of the proton beam from all systems, such that protons are delivered in an optimal therapeutic manner to the patient.

Herein, the main controller 110 refers to a single system controlling the charged particle beam system 100, to a single controller controlling a plurality of subsystems controlling the charged particle beam system 100, or to a plurality of individual controllers controlling one or more sub-systems of the charged particle beam system 100.

Synchrotron

Herein, the term synchrotron is used to refer to a system maintaining the charged particle beam in a circulating path; however, cyclotrons are alternatively used, albeit with their inherent limitations of energy, intensity, and extraction control. Further, the charged particle beam is referred to herein as circulating along a circulating path about a central point of the synchrotron. The circulating path is alternatively referred to as an orbiting path; however, the orbiting path does not refer a perfect circle or ellipse, rather it refers to cycling of the protons around a central point or region.

Referring now to Figure 2, an illustrative exemplary embodiment of one version of the charged particle beam system 100 is provided. The number, position, and described type of components is illustrative and non-limiting in nature. In the illustrated embodiment, an injector system 210 or ion source or charged particle beam source generates protons. The protons are delivered into a vacuum tube that runs into, through, and out of the synchrotron. The generated protons are delivered along an initial path 262. Focusing magnets 230, such as quadrupole magnets or injection quadrupole magnets, are used to focus the proton beam path. A quadrupole magnet is a focusing magnet. An injector bending magnet 232 bends the proton beam toward the plane of the synchrotron 130. The focused protons having an initial energy are introduced into an injector magnet 240, which is preferably an injection Lamberson magnet. Typically, the initial beam path 262 is along an axis off of, such as above, a circulating plane of the synchrotron 130. The injector bending magnet 232 and injector magnet 240 combine to move the protons into the synchrotron 130. Main bending magnets 250 or dipole magnets or circulating magnets are used to turn the protons along a circulating beam path 264. A dipole magnet is a bending magnet. The main bending magnets 250 bend the initial beam path 262 into a circulating beam path 264. In this example, the main bending magnets 250 or circulating magnets are represented as four sets of four magnets to maintain the circulating beam path 264 into a stable circulating beam path. However, any number of magnets or sets of magnets are optionally used to move the protons around a single orbit in

the circulation process. The protons pass through an accelerator 270. The accelerator accelerates the protons in the circulating beam path 264. As the protons are accelerated, the fields applied by the magnets are increased. Particularly, the speed of the protons achieved by the accelerator 270 are synchronized with magnetic fields of the main bending magnets 250 or circulating magnets to maintain stable circulation of the protons about a central point or region 280 of the synchrotron. At separate points in time the accelerator 270 / main bending magnet 250 combination is used to accelerate and/or decelerate the circulating protons while maintaining the protons in the circulating path or orbit. An extraction element of the inflector/deflector system 290 is used in combination with a Lamberson extraction magnet 292 to remove protons from their circulating beam path 264 within the synchrotron 130. One example of a deflector component is a Lamberson magnet. Typically the deflector moves the protons from the circulating plane to an axis off of the circulating plane, such as above the circulating plane. Extracted protons are preferably directed and/or focused using an extraction bending magnet 237 and extraction focusing magnets 235, such as quadrupole magnets along a transport path 268 into the scanning / targeting / delivery system 140. Two components of a scanning system 140 or targeting system typically include a first axis control 142, such as a vertical control, and a second axis control 144, such as a horizontal control. A nozzle system 146 is used for imaging the proton beam and/or as a vacuum barrier between the low pressure beam path of the synchrotron and the atmosphere. Protons are delivered with control to the patient interface module 150 and to a tumor of a patient. All of the above listed elements are optional and may be used in various permutations and combinations.

Ion Beam Generation System

An ion beam generation system generates a negative ion beam, such as a hydrogen anion or H^- beam; preferably focuses the negative ion beam; converts the negative ion beam to a positive ion beam, such as a proton or H^+ beam; and

injects the positive ion beam into the synchrotron 130. Portions of the ion beam path are preferably under partial vacuum. Each of these systems are further described, *infra*.

Referring now to Figure 3, an exemplary ion beam generation system 300 is illustrated. As illustrated, the ion beam generation system 300 has four major elements: a negative ion source 310, a first partial vacuum system 330, an optional ion beam focusing system 350, and a tandem accelerator 390.

Still referring to Figure 3, the negative ion source 310 preferably includes an inlet port 312 for injection of hydrogen gas into a high temperature plasma chamber 314. In one embodiment, the plasma chamber includes a magnetic material 316, which provides a magnetic field barrier 317 between the high temperature plasma chamber 314 and a low temperature plasma region on the opposite side of the magnetic field barrier. An extraction pulse is applied to a negative ion extraction electrode 318 to pull the negative ion beam into a negative ion beam path 319, which proceeds through the first partial vacuum system 330, through the ion beam focusing system 350, and into the tandem accelerator 390.

Still referring to Figure 3, the first partial vacuum system 330 is an enclosed system running from the hydrogen gas inlet port 312 to the tandem accelerator 390 conversion foil 395. The foil 395 is sealed directly or indirectly to the edges of the vacuum tube 320 providing for a higher pressure, such as about 10^{-5} torr, to be maintained on the first partial vacuum system 330 side of the foil 395 and a lower pressure, such as about 10^{-7} torr, to be maintained on the synchrotron side of the foil 390. By only pumping first partial vacuum system 330 and by only semi-continuously operating the ion beam source vacuum based on sensor readings, the lifetime of the semi-continuously operating pump is extended. The sensor readings are further described, *infra*.

Still referring to Figure 3, the first partial vacuum system 330 preferably includes: a first pump 332, such as a continuously operating pump and/or a turbo molecular pump; a large holding volume 334; and a semi-continuously operating pump 336. Preferably, a pump controller 340 receives a signal from a pressure sensor 342 monitoring pressure in the large holding volume 334. Upon a signal representative of a sufficient pressure in the large holding volume 334, the pump controller 340 instructs an actuator 345 to open a valve 346 between the large holding volume and the semi-continuously operating pump 336 and instructs the semi-continuously operating pump to turn on and pump to atmosphere residual gases out of the vacuum line 320 about the charged particle stream. In this fashion, the lifetime of the semi-continuously operating pump is extended by only operating semi-continuously and as needed. In one example, the semi-continuously operating pump 336 operates for a few minutes every few hours, such as 5 minutes every 4 hours, thereby extending a pump with a lifetime of about 2,000 hours to about 96,000 hours.

Further, by isolating the inlet gas from the synchrotron vacuum system, the synchrotron vacuum pumps, such as turbo molecular pumps can operate over a longer lifetime as the synchrotron vacuum pumps have fewer gas molecules to deal with. For example, the inlet gas is primarily hydrogen gas but may contain impurities, such as nitrogen and carbon dioxide. By isolating the inlet gases in the negative ion source system 310, first partial vacuum system 330, ion beam focusing system 350 and negative ion beam side of the tandem accelerator 390, the synchrotron vacuum pumps can operate at lower pressures with longer lifetimes, which increases the efficiency of the synchrotron 130.

Still referring to Figure 3, the ion beam focusing system 350 includes two or more electrodes where one electrode of each electrode pair partially obstructs the ion beam path with conductive paths 372, such as a conductive mesh. In the

illustrated example, three ion beam focusing system sections are illustrated, a two electrode ion focusing section 360, a first three electrode ion focusing section 370, and a second three electrode ion focusing section 380. In a given electrode pair, electric field lines, running between the conductive mesh of a first electrode and a second electrode, provide inward forces focusing the negative ion beam. Multiple such electrode pairs provide multiple negative ion beam focusing regions. Preferably the two electrode ion focusing section 360, first three electrode ion focusing section 370, and second three electrode ion focusing section 380 are placed after the negative ion source and before the tandem accelerator and/or cover a space of about 0.5, 1, or 2 meters along the ion beam path. Ion beam focusing systems are further described, *infra*.

Still referring to Figure 3, the tandem accelerator 390 preferably includes a foil 395, such as a carbon foil. The negative ions in the negative ion beam path 319 are converted to positive ions, such as protons, and the initial ion beam path 262 results. The foil 395 is preferably sealed directly or indirectly to the edges of the vacuum tube 320 providing for a higher pressure, such as about 10^{-5} torr, to be maintained on the side of the foil 395 having the negative ion beam path 319 and a lower pressure, such as about 10^{-7} torr, to be maintained on the side of the foil 390 having the proton ion beam path 262. Having the foil 395 physically separating the vacuum chamber 320 into two pressure regions allows for a system having fewer and/or smaller pumps to maintain the lower pressure system in the synchrotron 130 as the inlet hydrogen and its residuals are extracted in a separate contained and isolated space by the first partial vacuum system 330.

Negative Ion Source

An example of the negative ion source 310 is further described herein. Referring now to Figure 4, a cross-section of an exemplary negative ion source system 400 is provided. The negative ion beam 319 is created in multiple stages. During a

first stage, hydrogen gas is injected into a chamber. During a second stage, a negative ion is created by application of a first high voltage pulse, which creates a plasma about the hydrogen gas to create negative ions. During a third stage, a magnetic field filter is applied to components of the plasma. During a fourth stage, the negative ions are extracted from a low temperature plasma region, on the opposite side of the magnetic field barrier, by application of a second high voltage pulse. Each of the four stages are further described, *infra*. While the chamber is illustrated as a cross-section of a cylinder, the cylinder is exemplary only and any geometry applies to the magnetic loop containment walls, described *infra*.

In the first stage, hydrogen gas is injected through the inlet port 312 into a high temperature plasma region 490. The injection port 442 is open for a short period of time, such as less than about 1, 5, or 10 microseconds to minimize vacuum pump requirements to maintain vacuum chamber 320 requirements. The high temperature plasma region is maintained at reduced pressure by the partial vacuum system 330. The injection of the hydrogen gas is optionally controlled by the main controller 110, which is responsive to imaging system 170 information and patient interface module 150 information, such as patient positioning and period in a breath cycle.

In the second stage, a high temperature plasma region is created by applying a first high voltage pulse across a first electrode 422 and a second electrode 424. For example a 5 kV pulse is applied for about 20 microseconds with 5kV at the second electrode 424 and about 0 kV applied at the first electrode 422. Hydrogen in the chamber is broken, in the high temperature plasma region 490, into component parts, such as any of: atomic hydrogen, H^0 , a proton, H^+ , an electron, e^- , a hydrogen anion, and H^- .

In the third stage, the high temperature plasma region 490 is at least partially separated from a low temperature plasma region or zone 492 by a magnetic field or magnetic field barrier 430. High energy electrons are restricted from passing through the magnetic field barrier 430. In this manner, the magnetic field barrier 430 acts as a filter between, zone A and zone B, in the negative ion source. Preferably, a central magnetic material 410 is placed within the high temperature plasma region 490, such as along a central axis of the high temperature plasma region 490. Preferably, the first electrode 422 and second electrode 424 are composed of magnetic materials, such as iron. Preferably, the outer walls 450 of the high temperature plasma region, such as cylinder walls, are composed of a magnetic material, such as a permanent magnet, ferric, or iron based material, or a ferrite dielectric ring magnet. In this manner a magnetic field loop is created by: the central magnetic material 410, first electrode 422, the outer walls 450, the second electrode 424, and the magnetic field barrier 430. Again, the magnetic field barrier 430 restricts high energy electrons from passing through the magnetic field barrier 430. Low energy electrons interact with atomic hydrogen, H^0 , to create a hydrogen anion, H^- , in the low temperature plasma region 492.

In the fourth stage, a second high voltage pulse or extraction pulse is applied at a third electrode 426. The second high voltage pulse is preferentially applied during the later period of application of the first high voltage pulse. For example, an extraction pulse of about 25 kV is applied for about the last 5 microseconds of the first creation pulse of about 20 microseconds. The potential difference, of about 20 kV, between the third electrode 426 and second electrode 424 extracts the negative ion, H^- , from the low temperature plasma region 492 and initiates the negative ion beam 390, from zone B to zone C.

The magnetic field barrier 430 is optionally created in number of ways. An example of creation of the magnetic field barrier 430 using coils is provided. In

this example, the elements described, *supra*, in relation to Figure 4 are maintained with several differences. First, the magnetic field is created using coils. An isolating material is preferably provided between the first electrode 422 and the cylinder walls 450 as well as between the second electrode 424 and the cylinder walls 450. The central material 410 and/or cylinder walls 450 are optionally metallic. In this manner, the coils create a magnetic field loop through the first electrode 422, isolating material, outer walls 450, second electrode 424, magnetic field barrier 430, and the central material 410. Essentially, the coils generate a magnetic field in place of production of the magnetic field by the magnetic material 410. The magnetic field barrier 430 operates as described, *supra*. Generally, any manner that creates the magnetic field barrier 430 between the high temperature plasma region 490 and low temperature plasma region 492 is functionally applicable to the ion beam extraction system 400.

Ion Beam Focusing System

Referring now to Figure 5, the ion beam focusing system 350 is further described. In this example, three electrodes are used. In this example, the first electrode 510 and third electrode 530 are both negatively charged and each is a ring electrode circumferentially enclosing or at least partially enclosing the negative ion beam path 319. The second electrode 520 is positively charged and is also a ring electrode circumferentially enclosing the negative ion beam path. In addition, the second electrode includes one or more conducting paths 372 running through the negative ion beam path 319. For example, the conducting paths are a wire mesh, a conducting grid, or a series of substantially parallel conducting lines running across the second electrode. In use, electric field lines run from the conducting paths of the positively charged electrode to the negatively charged electrodes. For example, in use the electric field lines 540 run from the conducting paths 372 in the negative ion beam path 319 to the negatively charged electrodes 510, 530. Two ray trace lines 550, 560 of the negative ion beam path are used to illustrate focusing forces. In the first ray

trace line 550, the negative ion beam encounters a first electric field line at point M. Negatively charged ions in the negative ion beam 550 encounter forces running up the electric field line 571, illustrated with an x-axis component vector 572. The x-axis component force vectors 572 alters the trajectory of the first ray trace line to a inward focused vector 552, which encounters a second electric field line at point N. Again, the negative ion beam 552 encounters forces running up the electric field line 573, illustrated as having an inward force vector with an x-axis component 574, which alters the inward focused vector 552 to a more inward focused vector 554. Similarly, in the second ray trace line 560, the negative ion beam encounters a first electric field line at point O. Negatively charged ions in the negative ion beam encounter forces running up the electric field line 575, illustrated as having a force vector with an x-axis force 576. The inward force vectors 576 alters the trajectory of the second ray trace line 560 to an inward focused vector 562, which encounters a second electric field line at point P. Again, the negative ion beam encounters forces running up the electric field line 577, illustrated as having force vector with an x-axis component 578, which alters the inward focused vector 562 to a more inward focused vector 564. The net result is a focusing effect on the negative ion beam. Each of the force vectors 572, 574, 576, 578 optionally has x and/or y force vector components resulting in a 3-dimensional focusing of the negative ion beam path. Naturally, the force vectors are illustrative in nature, many electric field lines are encountered, and the focusing effect is observed at each encounter resulting in integral focusing. The example is used to illustrate the focusing effect.

Still referring to Figure 5, optionally any number of electrodes are used, such as 2, 3, 4, 5, 6, 7, 8, or 9 electrodes, to focus the negative ion beam path where every other electrode, in a given focusing section, is either positively or negatively charged. For example, three focusing sections are optionally used. In the first ion focusing section 360, a pair of electrodes are used where the first electrode encountered along the negative ion beam path is negatively charged and the second electrode is positively charged, resulting in focusing of the

negative ion beam path. In the second ion focusing section 370, two pairs of electrodes are used, where a common positively charged electrode with a conductive mesh running through the negatively ion beam path 319 is used. Thus, in the second ion focusing section 370, the first electrode encountered along the negative ion beam path is negatively charged and the second electrode is positively charged, resulting in focusing of the negative ion beam path. Further, in the second ion focusing section, moving along the negative ion beam path, a second focusing effect is observed between the second positively charged electrode and a third negatively charged electrode. In this example, a third ion focusing section 380 is used that again has three electrodes, which acts in the fashion of the second ion focusing section, describe *supra*.

Referring now to Figure 6, the central regions of the electrodes in the ion beam focusing system 350 is further described. Referring now to Figure 5A, the central region of the negatively charged ring electrode 510 is preferably void of conductive material. Referring now to Figures 6B-D, the central region of positively charged electrode ring 520 preferably contains conductive paths 372. Preferably, the conductive paths 372 or conductive material within the positively charged electrode ring 520 blocks about 1, 2, 5, or 10 percent of the area and more preferably blocks about 5 percent of the cross-sectional area of the negative ion beam path 319. Referring now to Figure 6B, one option is a conductive mesh 610. Referring now to Figure 6C, a second option is a series of conductive lines 620 running substantially in parallel across the positively charged electrode ring 520 that surrounds a portion of the negative ion beam path 319. Referring now to Figure 6D, a third option is to have a foil 630 or metallic layer cover all of the cross-sectional area of the negative ion beam path with holes punched through the material, where the holes take up about 90-99 percent and more preferably about 95 percent of the area of the foil. More generally, the pair of electrodes are configured to provide electric field lines that provide focusing force vectors to the negative ion beam when the ions in the negative ion beam translate through the electric field lines, as described *supra*.

In an example of a two electrode negative beam ion focusing system having a first cross-sectional diameter, d_1 , the negative ions are focused using the two electrode system to a second cross-sectional diameter, d_2 , where $d_1 > d_2$. Similarly, in an example of a three electrode negative ion beam focusing system is provided having a first cross-sectional diameter, d_1 , the negative ions are focused using the three electrode system to a third cross-sectional diameter, d_3 , where $d_1 > d_3$. For like potentials on the electrodes, the three electrode system provides tighter or stronger focusing compared to the two-electrode system, $d_3 < d_2$.

In the examples provided, *supra*, of a multi-electrode ion beam focusing system, the electrodes are rings. More generally, the electrodes are of any geometry sufficient to provide electric field lines that provide focusing force vectors to the negative ion beam when the ions in the negative ion beam translate through the electric field lines, as described *supra*. For example, one negative ring electrode is optionally replaced by a number of negatively charged electrodes, such as about 2, 3, 4, 6, 8, 10, or more electrodes placed about the outer region of a cross-sectional area of the negative ion beam probe. Generally, more electrodes are required to converge or diverge a faster or higher energy beam.

In another embodiment, by reversing the polarity of electrodes in the above example, the negative ion beam is made to diverge. Thus, the negative ion beam path is optionally focused and expanded using combinations of electrode pairs. For example, if the electrode having the mesh across the negative ion beam path is made negative, then the negative ion beam path is made to defocus. Hence, combinations of electrode pairs are used for focusing and defocusing a negative ion beam path, such as where a first pair includes a positively charged mesh for focusing and a where a second pair includes a negatively charged mesh for defocusing.

Tandem Accelerator

Referring now to Figure 7A, the tandem accelerator 390 is further described. The tandem accelerator accelerates ions using a series of electrodes 710, 711, 712, 713, 714, 715. For example, negative ions, such as H^- , in the negative ion beam path are accelerated using a series of electrodes having progressively higher voltages relative to the voltage of the extraction electrode 426, or third electrode 426, of the negative ion beam source 310. For instance, the tandem accelerator 390 optionally has electrodes ranging from the 25 kV of the extraction electrode 426 to about 525 kV near the foil 395 in the tandem accelerator 390. Upon passing through the foil, the negative ion, H^- , loses two electrons to yield a proton, H^+ , according to equation 1.



The proton is further accelerated in the tandem accelerator using appropriate voltages at a multitude of further electrodes 713, 714, 715. The protons are then injected into the synchrotron 130 as described, *supra*.

Still referring to Figure 7, the foil 395 in the tandem accelerator 390 is further described. The foil 395 is preferably a very thin carbon film of about 30 to 200 angstroms in thickness. The foil thickness is designed to both: (1) not block the ion beam and (2) allow the transfer of electrons yielding protons to form the proton beam path 262. The foil 395 is preferably substantially in contact with a support layer 720, such as a support grid. The support layer 720 provides mechanical strength to the foil 395 to combine to form a vacuum blocking element 725. The foil 395 blocks nitrogen, carbon dioxide, hydrogen, and other gases from passing and thus acts as a vacuum barrier. In one embodiment, the foil 395 is preferably sealed directly or indirectly to the edges of the vacuum tube 320 providing for a higher pressure, such as about 10^{-5} torr, to be maintained on the side of the foil 395 having the negative ion beam path 319 and a lower

pressure, such as about 10^{-7} torr, to be maintained on the side of the foil 395 having the proton ion beam path 262. Having the foil 395 physically separating the vacuum chamber 320 into two pressure regions allows for a vacuum system having fewer and/or smaller pumps to maintain the lower pressure system in the synchrotron 130 as the inlet hydrogen and its residuals are extracted in a separate contained and isolated space by the first partial vacuum system 330. The foil 395 and support layer 720 are preferably attached to the structure 750 of the tandem accelerator 390 or vacuum tube 320 to form a pressure barrier using any mechanical means, such as a metal, plastic, or ceramic ring 730 compressed to the walls with an attachment screw 740. Any mechanical means for separating and sealing the two vacuum chamber sides with the foil 395 are equally applicable to this system. Referring now to Figure 7B, the support structure 720 and foil 395 are individually viewed in the x-, y-plane.

Referring now to Figure 8, another exemplary method of use of the charged particle beam system 100 is provided. The main controller 110, or one or more sub-controllers, controls one or more of the subsystems to accurately and precisely deliver protons to a tumor of a patient. For example, the main controller sends a message to the patient indicating when or how to breath. The main controller 110 obtains a sensor reading from the patient interface module, such as a temperature breath sensor or a force reading indicative of where in a breath cycle the subject is. The main controller collects an image, such as a portion of a body and/or of a tumor, from the imaging system 170. The main controller 110 also obtains position and/or timing information from the patient interface module 150. The main controller 110 then optionally controls the injection system 120 to inject hydrogen gas into a negative ion beam source 310 and controls timing of extraction of the negative ion from the negative ion beam source 310. Optionally, the main controller controls ion beam focusing using the ion beam focusing lens system 350; acceleration of the proton beam with the tandem accelerator 390; and/or injection of the proton into the synchrotron 130. The synchrotron typically contains at least an accelerator system 132 and an extraction system 134. The

synchrotron preferably contains one or more of: turning magnets, edge focusing magnets, magnetic field concentration magnets, winding and correction coils, and flat magnetic field incident surfaces, some of which contain elements under control by the main controller 110. The main controller preferably controls the proton beam within the accelerator system, such as by controlling speed, trajectory, and/or timing of the proton beam. The main controller then controls extraction of a proton beam from the accelerator through the extraction system 134. For example, the controller controls timing, energy, and/or intensity of the extracted beam. The controller 110 also preferably controls targeting of the proton beam through the targeting / delivery system 140 to the patient interface module 150. One or more components of the patient interface module 150 are preferably controlled by the main controller 110, such as vertical position of the patient, rotational position of the patient, and patient chair positioning / stabilization / control elements. Further, display elements of the display system 160 are preferably controlled via the main controller 110. Displays, such as display screens, are typically provided to one or more operators and/or to one or more patients. In one embodiment, the main controller 110 times the delivery of the proton beam from all systems, such that protons are delivered in an optimal therapeutic manner to the patient.

Circulating System

A synchrotron 130 preferably comprises a combination of straight sections 910 and ion beam turning sections 920. Hence, the circulating path of the protons is not circular in a synchrotron, but is rather a polygon with rounded corners.

In one illustrative embodiment, the synchrotron 130, which is also referred to as an accelerator system, has four straight elements and four turning sections. Examples of straight sections 910 include the: inflector 240, accelerator 270, extraction system 290, and deflector 292. Along with the four straight sections

are four ion beam turning sections 920, which are also referred to as magnet sections or turning sections. Turning sections are further described, *infra*.

Referring now to Figure 9, an exemplary synchrotron is illustrated. In this example, protons delivered along the initial proton beam path 262 are inflected into the circulating beam path with the inflector 240 and after acceleration are extracted via a deflector 292 to a beam transport path 268. In this example, the synchrotron 130 comprises four straight sections 910 and four bending or turning sections 920 where each of the four turning sections use one or more magnets to turn the proton beam about ninety degrees. As is further described, *infra*, the ability to closely space the turning sections and efficiently turn the proton beam results in shorter straight sections. Shorter straight sections allows for a synchrotron design without the use of focusing quadrupoles in the circulating beam path of the synchrotron. The removal of the focusing quadrupoles from the circulating proton beam path results in a more compact design. In this example, the illustrated synchrotron has about a five meter diameter versus eight meter and larger cross-sectional diameters for systems using a quadrupole focusing magnet in the circulating proton beam path.

Referring now to Figure 10, additional description of the first bending or turning section 920 is provided. Each of the turning sections preferably comprises multiple magnets, such as about 2, 4, 6, 8, 10, or 12 magnets. In this example, four turning magnets 1010, 1020, 1030, 1040 in the first turning section 20 are used to illustrate key principles, which are the same regardless of the number of magnets in a turning section 920. A turning magnet 1010 is a particular type of main bending or circulating magnet 250.

In physics, the Lorentz force is the force on a point charge due to electromagnetic fields. The Lorentz force is given by equation 2 in terms of magnetic fields with the electric field terms not included.

$$\mathbf{F} = q(\mathbf{v} \times \mathbf{B}) \quad \text{eq. 2}$$

In equation 2, \mathbf{F} is the force in newtons; \mathbf{B} is the magnetic field in Teslas; and \mathbf{v} is the instantaneous velocity of the particles in meters per second.

Referring now to Figure 11, an example of a single magnet bending or turning section 1010 is expanded. The turning section includes a gap 1110 through which protons circulate. The gap 1110 is preferably a flat gap, allowing for a magnetic field across the gap 1110 that is more uniform, even, and intense. A magnetic field enters the gap 1110 through a magnetic field incident surface and exits the gap 1110 through a magnetic field exiting surface. The gap 1110 runs in a vacuum tube between two magnet halves. The gap 1110 is controlled by at least two parameters: (1) the gap 1110 is kept as large as possible to minimize loss of protons and (2) the gap 1110 is kept as small as possible to minimize magnet sizes and the associated size and power requirements of the magnet power supplies. The flat nature of the gap 1110 allows for a compressed and more uniform magnetic field across the gap 1110. One example of a gap dimension is to accommodate a vertical proton beam size of about 2 cm with a horizontal beam size of about 5 to 6 cm.

As described, *supra*, a larger gap size requires a larger power supply. For instance, if the gap 1110 size doubles in vertical size, then the power supply requirements increase by about a factor of 4. The flatness of the gap 1110 is also important. For example, the flat nature of the gap 1110 allows for an increase in energy of the extracted protons from about 250 to about 330 MeV.

More particularly, if the gap 1110 has an extremely flat surface, then the limits of a magnetic field of an iron magnet are reachable. An exemplary precision of the flat surface of the gap 1110 is a polish of less than about 5 microns and preferably with a polish of about 1 to 3 microns. Unevenness in the surface results in imperfections in the applied magnetic field. The polished flat surface spreads unevenness of the applied magnetic field.

Still referring to Figure 11, the charged particle beam moves through the gap 1110 with an instantaneous velocity, v . A first magnetic coil 1120 and a second magnetic coil 1130 run above and below the gap 1110, respectively. Current running through the coils 1120, 1130 results in a magnetic field, B , running through the single magnet turning section 1010. In this example, the magnetic field, B , runs upward, which results in a force, F , pushing the charged particle beam inward toward a central point of the synchrotron, which turns the charged particle beam in an arc.

Still referring to Figure 11, a portion of an optional second magnet bending or turning section 1020 is illustrated. The coils 1120, 1130 typically have return elements 1140, 1150 or turns at the end of one magnet, such as at the end of the first magnet turning section 1010. The turns 1140, 1150 take space. The space reduces the percentage of the path about one orbit of the synchrotron that is covered by the turning magnets. This leads to portions of the circulating path where the protons are not turned and/or focused and allows for portions of the circulating path where the proton path defocuses. Thus, the space results in a larger synchrotron. Therefore, the space between magnet turning sections 1160 is preferably minimized. The second turning magnet is used to illustrate that the coils 1120, 1130 optionally run along a plurality of magnets, such as 2, 3, 4, 5, 6, or more magnets. Coils 1120, 1130 running across multiple turning section magnets allows for two turning section magnets to be spatially positioned closer

to each other due to the removal of the steric constraint of the turns, which reduces and/or minimizes the space 1160 between two turning section magnets.

Referring now to Figures 12 and 13, two illustrative 90 degree rotated cross-sections of single magnet bending or turning sections 1010 are presented. The magnet assembly has a first magnet 1210 and a second magnet 1220. A magnetic field induced by coils, described *infra*, runs between the first magnet 1210 to the second magnet 1220 across the gap 1110. Return magnetic fields run through a first yoke 1212 and second yoke 1222. The combined cross-section area of the return yokes roughly approximates the cross-sectional area of the first magnet 1210 or second magnet 1220. The charged particles run through the vacuum tube in the gap 1110. As illustrated, protons run into Figure 12 through the gap 1110 and the magnetic field, illustrated as vector B , applies a force F to the protons pushing the protons towards the center of the synchrotron, which is off page to the right in Figure 12. The magnetic field is created using windings. A first coil making up a first winding coil 1250, illustrated as dots in Figure 12 to representatively present cross-sections of the wire for individual windings and illustrated as individual windings in Figure 13. The second coil of wire making up a second winding coil 1260 is similarly illustratively represented. Isolating or concentrating gaps 1230, 1240, such as air gaps, isolate the iron based yokes from the gap 1110. The gap 1110 is approximately flat to yield a uniform magnetic field across the gap 1110, as described *supra*.

Still referring to Figure 13, the ends of a single bending or turning magnet are preferably beveled. Nearly perpendicular or right angle edges of a turning magnet 1010 are represented by dashed lines 1374, 1384. The dashed lines 1374, 1384 intersect at a point 1390 beyond the center of the synchrotron 280. Preferably, the edge of the turning magnet is beveled at angles alpha, α , and beta, β , which are angles formed by a first line 1372, 1382 going from an edge of the turning magnet 1010 and the center 280 and a second line 1374, 1384 going

from the same edge of the turning magnet and the intersecting point 1390. The angle alpha is used to describe the effect and the description of angle alpha applies to angle beta, but angle alpha is optionally different from angle beta. The angle alpha provides an edge focusing effect. Beveling the edge of the turning magnet 1010 at angle alpha focuses the proton beam.

Multiple turning magnets provide multiple magnet edges that each have edge focusing effects in the synchrotron 130. If only one turning magnet is used, then the beam is only focused once for angle alpha or twice for angle alpha and angle beta. However, by using smaller turning magnets, more turning magnets fit into the turning sections 920 of the synchrotron 130. For example, if four magnets are used in a turning section 920 of the synchrotron, then for a single turning section there are eight possible edge focusing effect surfaces, two edges per magnet. The eight focusing surfaces yield a smaller cross-sectional beam size. This allows the use of a smaller gap 1110.

The use of multiple edge focusing effects in the turning magnets results in not only a smaller gap 1110, but also the use of smaller magnets and smaller power supplies. For a synchrotron 130 having four turning sections 920 where each turning sections has four turning magnets and each turning magnet has two focusing edges, a total of thirty-two focusing edges exist for each orbit of the protons in the circulating path of the synchrotron 130. Similarly, if 2, 6, or 8 magnets are used in a given turning section, or if 2, 3, 5, or 6 turning sections are used, then the number of edge focusing surfaces expands or contracts according to equation 3.

$$TFE = NTS * \frac{M}{NTS} * \frac{FE}{M} \quad \text{eq. 3}$$

where TFE is the number of total focusing edges, NTS is the number of turning sections, M is the number of magnets, and FE is the number of focusing edges. Naturally, not all magnets are necessarily beveled and some magnets are optionally beveled on only one edge.

The inventors have determined that multiple smaller magnets have benefits over fewer larger magnets. For example, the use of 16 small magnets yields 32 focusing edges whereas the use of 4 larger magnets yields only 8 focusing edges. The use of a synchrotron having more focusing edges results in a circulating path of the synchrotron built without the use of focusing quadrupoles magnets. All prior art synchrotrons use quadrupoles in the circulating path of the synchrotron. Further, the use of quadrupoles in the circulating path necessitates additional straight sections in the circulating path of the synchrotron. Thus, the use of quadrupoles in the circulating path of a synchrotron results in synchrotrons having larger diameters, circulating beam pathlengths, and/or larger circumferences.

In various embodiments of the system described herein, the synchrotron has any combination of:

- at least 4 and preferably 6, 8, 10, or more edge focusing edges per 90 degrees of turn of the charged particle beam in a synchrotron having four turning sections;
- at least about 16 and preferably about 24, 32, or more edge focusing edges per orbit of the charged particle beam in the synchrotron;
- only 4 turning sections where each of the turning sections includes at least 4 and preferably 8 edge focusing edges;
- an equal number of straight sections and turning sections;
- exactly 4 turning sections;

- at least 4 edge focusing edges per turning section;
- no quadrupoles in the circulating path of the synchrotron;
- a rounded corner rectangular polygon configuration;
- a circumference of less than 60 meters;
- a circumference of less than 60 meters and 32 edge focusing surfaces;
and/or
- any of about 8, 16, 24, or 32 non-quadrupole magnets per circulating path of the synchrotron, where the non-quadrupole magnets include edge focusing edges.

Referring now to Figure 12, the incident magnetic field surface 1270 of the first magnet 1210 is further described. Figure 12 is not to scale and is illustrative in nature. Local imperfections or unevenness in quality of the finish of the incident surface 1270 results in inhomogeneities or imperfections in the magnetic field applied to the gap 1110. Preferably, the incident surface 1270 is flat, such as to within about a zero to three micron finish polish, or less preferably to about a ten micron finish polish.

Referring now to Figure 14, additional magnet elements, of the magnet cross-section illustratively represented in Figure 12, are described. The first magnet 1210 preferably contains an initial cross-section distance 1410 of the iron based core. The contours of the magnetic field are shaped by the magnets 1210, 1220 and the yokes 1212, 1222. The iron based core tapers to a second cross-section distance 1420. The magnetic field in the magnet preferentially stays in the iron based core as opposed to the gaps 1230, 1240. As the cross-section distance decreases from the initial cross-section distance 1410 to the final cross-section distance 1420, the magnetic field concentrates. The change in shape of the magnet from the longer distance 1410 to the smaller distance 1420 acts as an

amplifier. The concentration of the magnetic field is illustrated by representing an initial density of magnetic field vectors 1430 in the initial cross-section 1410 to a concentrated density of magnetic field vectors 1440 in the final cross-section 1420. The concentration of the magnetic field due to the geometry of the turning magnets results in fewer winding coils 1250, 1260 being required and also a smaller power supply to the coils being required.

Example I

In one example, the initial cross-section distance 1410 is about fifteen centimeters and the final cross-section distance 1420 is about ten centimeters. Using the provided numbers, the concentration of the magnetic field is about 15/10 or 1.5 times at the incident surface 1270 of the gap 1110, though the relationship is not linear. The taper 1460 has a slope, such as about 20, 40, or 60 degrees. The concentration of the magnetic field, such as by 1.5 times, leads to a corresponding decrease in power consumption requirements to the magnets.

Referring now to Figure 15, an additional example of geometry of the magnet used to concentrate the magnetic field is illustrated. As illustrated in Figure 14, the first magnet 1210 preferably contains an initial cross-section distance 1410 of the iron based core. The contours of the magnetic field are shaped by the magnets 1210, 1220 and the yokes 1212, 1222. In this example, the core tapers to a second cross-section distance 1420 with a smaller angle theta, θ . As described, *supra*, the magnetic field in the magnet preferentially stays in the iron based core as opposed to the gaps 1230, 1240. As the cross-section distance decreases from the initial cross-section distance 1410 to the final cross-section distance 1420, the magnetic field concentrates. The smaller angle, theta, results in a greater amplification of the magnetic field in going from the longer distance 1410 to the smaller distance 1420. The concentration of the magnetic field is illustrated by representing an initial density of magnetic field vectors 1430 in the initial cross-section 1410 to a concentrated density of magnetic field vectors 1440

in the final cross-section 1420. The concentration of the magnetic field due to the geometry of the turning magnets results in fewer winding coils 1250, 1260 being required and also a smaller power supply to the winding coils 1250, 1260 being required.

Referring again to Figure 15, the cross-sectional area of the second distance 1410 is less than about two-thirds of the cross-sectional area of the first cross-section distance 1420

Still referring to Figure 15, optional correction coils 1510, 1520 are illustrated that are used to correct the strength of one or more turning magnets. The correction coils 1520, 1530 supplement the winding coils 1250, 1260. The correction coils 1510, 1520 have correction coil power supplies that are separate from winding coil power supplies used with the winding coils 1250, 1260. The correction coil power supplies typically operate at a fraction of the power required compared to the winding coil power supplies, such as about 1, 2, 3, 5, 7, or 10 percent of the power and more preferably about 1 or 2 percent of the power used with the winding coils 1250, 1260. The smaller operating power applied to the correction coils 1510, 1520 allows for more accurate and/or precise control of the correction coils. The correction coils are used to adjust for imperfection in the turning magnets 1010, 1020, 1030, 1040. Optionally, separate correction coils are used for each turning magnet allowing individual tuning of the magnetic field for each turning magnet, which eases quality requirements in the manufacture of each turning magnet.

Referring now to Figure 16, an example of winding coils 1630 and correction coils 1620 about a plurality of turning magnets 1010, 1020 in an ion beam turning section 920 is illustrated. As illustrated, the winding coils two 1630 turning magnets and correction coils are illustrated correcting one 1640 and two 1620

turning magnets. However, the winding coils optionally cover one or more turning magnets, such as 1, 2, or 4 turning magnets. Similarly, the correction coils optionally cover one or more turning magnets, such as 1, 2, or 4 turning magnets. Preferably, the number of turning magnets covered is the same for the winding and correction coils. One or more high precision magnetic field sensors 1830 are placed into the synchrotron and are used to measure the magnetic field at or near the proton beam path. For example, the magnetic sensors are optionally placed between turning magnets and/or within a turning magnet, such as at or near the gap 1110 or at or near the magnet core or yoke. The sensors are part of a feedback system to the correction coils, which is optionally run by the main controller. Thus, the system preferably stabilizes the magnetic field in the synchrotron elements rather than stabilizing the current applied to the magnets. Stabilization of the magnetic field allows the synchrotron to come to a new energy level quickly. This allows the system to be controlled to an operator or algorithm selected energy level with each pulse of the synchrotron and/or with each breath of the patient. Optional magnetic field sensors 1650 placed near a turning magnet or between turning magnets are optionally used as inputs to control systems controlling the magnetic field strength.

The winding and/or correction coils correct 1, 2, 3, or 4 turning magnets, and preferably correct a magnetic field generated by two turning magnets. A winding or correction coil covering multiple magnets reduces space between magnets as fewer winding or correction coil ends are required, which occupy space.

Example II

Referring now to Figure 17, an example is used to clarify the magnetic field control using a feedback loop 1700 to change delivery times and/or periods of proton pulse delivery. In one case, a respiratory sensor 1710 senses the breathing cycle of the subject. The respiratory sensor sends the information to an algorithm in a magnetic field controller 1720, typically via the patient interface

module 150 and/or via the main controller 110 or a subcomponent thereof. The algorithm predicts and/or measures when the subject is at a particular point in the breathing cycle, such as at the bottom of a breath. Magnetic field sensors 1730 are used as input to the magnetic field controller, which controls a magnet power supply 1740 for a given magnetic field, such as within a first turning magnet 1010 of a synchrotron 130. The control feedback loop is thus used to dial the synchrotron to a selected energy level and deliver protons with the desired energy at a selected point in time, such as at the bottom of the breath. More particularly, the main controller injects protons into the synchrotron and accelerates the protons in a manner that combined with extraction delivers the protons to the tumor at a selected point in the breathing cycle. Intensity of the proton beam is also selectable and controllable by the main controller at this stage. The feedback control to the correction coils allows rapid selection of energy levels of the synchrotron that are tied to the patient's breathing cycle. This system is in stark contrast to a system where the current is stabilized and the synchrotron deliver pulses with a period, such as 10 or 20 cycles per second with a fixed period.

The feedback or the magnetic field design coupled with the correction coils allows for the extraction cycle to match the varying respiratory rate of the patient.

Traditional extraction systems do not allow this control as magnets have memories in terms of both magnitude and amplitude of a sine wave. Hence, in a traditional system, in order to change frequency, slow changes in current must be used. However, with the use of the feedback loop using the magnetic field sensors, the frequency and energy level of the synchrotron are rapidly adjustable. Further aiding this process is the use of a novel extraction system that allows for acceleration of the protons during the extraction process, described *infra*.

Example III

Referring again to Figure 16, an example of a winding coil 1630 that covers four turning magnets 1010, 1020, 1030, 1040 is provided. Optionally, a first winding coil 1640 covers two magnets 1030, 1040 and a second winding coil covers another two magnets 1010, 1020. As described, *supra*, this system reduces space between turning section allowing more magnetic field to be applied per radian of turn. A first correction coil 1610 is illustrated that is used to correct the magnetic field for the first turning magnet 1010. A second correction coil 1620 is illustrated that is used to correct the magnetic field for a winding coil 1630 about four turning magnets. Individual correction coils for each turning magnet are preferred and individual correction coils yield the most precise and/or accurate magnetic field in each turning section. Particularly, the individual correction coil 1610 is used to compensate for imperfections in the individual magnet of a given turning section. Hence, with a series of magnetic field sensors, corresponding magnetic fields are individually adjustable in a series of feedback loops, via a magnetic field monitoring system, as an independent coil is used for each turning section. Alternatively, a multiple magnet correction coil is used to correct the magnetic field for a plurality of turning section magnets.

Flat Gap Surface

While the gap surface is described in terms of the first turning magnet 1010, the discussion applies to each of the turning magnets in the synchrotron. Similarly, while the gap 1110 surface is described in terms of the magnetic field incident surface 670, the discussion additionally optionally applies to the magnetic field exiting surface 680.

The magnetic field incident surface 1270 of the first magnet 1210 is preferably about flat, such as to within about a zero to three micron finish polish or less preferably to about a ten micron finish polish. By being very flat, the polished

surface spreads the unevenness of the applied magnetic field across the gap 1110. The very flat surface, such as about 0, 1, 2, 4, 6, 8, 10, 15, or 20 micron finish, allows for a smaller gap size, a smaller applied magnetic field, smaller power supplies, and tighter control of the proton beam cross-sectional area.

Proton Beam Extraction

Referring now to Figure 18, an exemplary proton extraction process from the synchrotron 130 is illustrated. For clarity, Figure 18 removes elements represented in Figure 2, such as the turning magnets, which allows for greater clarity of presentation of the proton beam path as a function of time. Generally, protons are extracted from the synchrotron 130 by slowing the protons. As described, *supra*, the protons were initially accelerated in a circulating path 264, which is maintained with a plurality of main bending magnets 250. The circulating path is referred to herein as an original central beamline 264. The protons repeatedly cycle around a central point in the synchrotron 280. The proton path traverses through a radio frequency (RF) cavity system 1810. To initiate extraction, an RF field is applied across a first blade 1812 and a second blade 1814, in the RF cavity system 1810. The first blade 1812 and second blade 1814 are referred to herein as a first pair of blades.

In the proton extraction process, an RF voltage is applied across the first pair of blades, where the first blade 1812 of the first pair of blades is on one side of the circulating proton beam path 264 and the second blade 1814 of the first pair of blades is on an opposite side of the circulating proton beam path 264. The applied RF field applies energy to the circulating charged-particle beam. The applied RF field alters the orbiting or circulating beam path slightly of the protons from the original central beamline 264 to an altered circulating beam path 265. Upon a second pass of the protons through the RF cavity system, the RF field further moves the protons off of the original proton beamline 264. For example, if the original beamline is considered as a circular path, then the altered beamline

is slightly elliptical. The applied RF field is timed to apply outward or inward movement to a given band of protons circulating in the synchrotron accelerator. Each orbit of the protons is slightly more off axis compared to the original circulating beam path 264. Successive passes of the protons through the RF cavity system are forced further and further from the original central beamline 264 by altering the direction and/or intensity of the RF field with each successive pass of the proton beam through the RF field.

The RF voltage is frequency modulated at a frequency about equal to the period of one proton cycling around the synchrotron for one revolution or at a frequency than is an integral multiplier of the period of one proton cycling about the synchrotron. The applied RF frequency modulated voltage excites a betatron oscillation. For example, the oscillation is a sine wave motion of the protons. The process of timing the RF field to a given proton beam within the RF cavity system is repeated thousands of times with each successive pass of the protons being moved approximately one micrometer further off of the original central beamline 264. For clarity, the approximately 1000 changing beam paths with each successive path of a given band of protons through the RF field are illustrated as the altered beam path 265.

With a sufficient sine wave betatron amplitude, the altered circulating beam path 265 touches a material 1830, such as a foil or a sheet of foil. The foil is preferably a lightweight material, such as beryllium, a lithium hydride, a carbon sheet, or a material of low nuclear charge. A material of low nuclear charge is a material composed of atoms consisting essentially of atoms having six or fewer protons. The foil is preferably about 10 to 150 microns thick, is more preferably 30 to 100 microns thick, and is still more preferably 40-60 microns thick. In one example, the foil is beryllium with a thickness of about 50 microns. When the protons traverse through the foil, energy of the protons is lost and the speed of the protons is reduced. Typically, a current is also generated, described *infra*.

Protons moving at a slower speed travel in the synchrotron with a reduced radius of curvature 266 compared to either the original central beamline 264 or the altered circulating path 265. The reduced radius of curvature 266 path is also referred to herein as a path having a smaller diameter of trajectory or a path having protons with reduced energy. The reduced radius of curvature 266 is typically about two millimeters less than a radius of curvature of the last pass of the protons along the altered proton beam path 265.

The thickness of the material 1830 is optionally adjusted to create a change in the radius of curvature, such as about $\frac{1}{2}$, 1, 2, 3, or 4 mm less than the last pass of the protons 265 or original radius of curvature 264. Protons moving with the smaller radius of curvature travel between a second pair of blades. In one case, the second pair of blades is physically distinct and/or are separated from the first pair of blades. In a second case, one of the first pair of blades is also a member of the second pair of blades. For example, the second pair of blades is the second blade 1814 and a third blade 1816 in the RF cavity system 1810. A high voltage DC signal, such as about 1 to 5 kV, is then applied across the second pair of blades, which directs the protons out of the synchrotron through an extraction magnet 292, such as a Lamberson extraction magnet, into a transport path 268.

Control of acceleration of the charged particle beam path in the synchrotron with the accelerator and/or applied fields of the turning magnets in combination with the above described extraction system allows for control of the intensity of the extracted proton beam, where intensity is a proton flux per unit time or the number of protons extracted as a function of time. For example, when a current is measured beyond a threshold, the RF field modulation in the RF cavity system is terminated or reinitiated to establish a subsequent cycle of proton beam extraction. This process is repeated to yield many cycles of proton beam extraction from the synchrotron accelerator.

Because the extraction system does not depend on any change in magnetic field properties, it allows the synchrotron to continue to operate in acceleration or deceleration mode during the extraction process. Stated differently, the extraction process does not interfere with synchrotron acceleration. In stark contrast, traditional extraction systems introduce a new magnetic field, such as via a hexapole, during the extraction process. More particularly, traditional synchrotrons have a magnet, such as a hexapole magnet, that is off during an acceleration stage. During the extraction phase, the hexapole magnetic field is introduced to the circulating path of the synchrotron. The introduction of the magnetic field necessitates two distinct modes, an acceleration mode and an extraction mode, which are mutually exclusive in time.

Charged Particle Beam Intensity Control

Control of applied field, such as a radio-frequency (RF) field, frequency and magnitude in the RF cavity system 1810 allows for intensity control of the extracted proton beam, where intensity is extracted proton flux per unit time or the number of protons extracted as a function of time.

Referring still to Figure 18, when protons in the proton beam hit the material 1830 electrons are given off resulting in a current. The resulting current is converted to a voltage and is used as part of a ion beam intensity monitoring system or as part of an ion beam feedback loop for controlling beam intensity. The voltage is optionally measured and sent to the main controller 110 or to a controller subsystem 1840. More particularly, when protons in the charged particle beam path pass through the material 1830, some of the protons lose a small fraction of their energy, such as about one-tenth of a percent, which results in a secondary electron. That is, protons in the charged particle beam push some electrons when passing through material 1830 giving the electrons enough energy to

cause secondary emission. The resulting electron flow results in a current or signal that is proportional to the number of protons going through the target material 1830. The resulting current is preferably converted to voltage and amplified. The resulting signal is referred to as a measured intensity signal.

The amplified signal or measured intensity signal resulting from the protons passing through the material 1830 is preferably used in controlling the intensity of the extracted protons. For example, the measured intensity signal is compared to a goal signal, which is predetermined in an irradiation of the tumor plan 1860. In one example, the tumor plan 1860 contains the goal or targeted energy and intensity of the delivered proton beam as a function of x-position, y-position, time, and/or rotational position of the patient. The difference between the measured intensity signal and the planned for goal signal is calculated. The difference is used as a control to the RF generator. Hence, the measured flow of current resulting from the protons passing through the material 1830 is used as a control in the RF generator to increase or decrease the number of protons undergoing betatron oscillation and striking the material 1830. Hence, the voltage determined off of the material 1830 is used as a measure of the orbital path and is used as a feedback control to control the RF cavity system. Alternatively, the measured intensity signal is not used in the feedback control and is just used as a monitor of the intensity of the extracted protons.

As described, *supra*, the photons striking the material 1830 is a step in the extraction of the protons from the synchrotron 130. Hence, the measured intensity signal is used to change the number of protons per unit time being extracted, which is referred to as intensity of the proton beam. The intensity of the proton beam is thus under algorithm control. Further, the intensity of the proton beam is controlled separately from the velocity of the protons in the synchrotron 130. Hence, intensity of the protons extracted and the energy of the protons extracted are independently variable.

For example, protons initially move at an equilibrium trajectory in the synchrotron 130. An RF field is used to excite the protons into a betatron oscillation. In one case, the frequency of the protons orbit is about 10 MHz. In one example, in about one millisecond or after about 10,000 orbits, the first protons hit an outer edge of the target material 130. The specific frequency is dependent upon the period of the orbit. Upon hitting the material 130, the protons push electrons through the foil to produce a current. The current is converted to voltage and amplified to yield a measured intensity signal. The measured intensity signal is used as a feedback input to control the applied RF magnitude, RF frequency, or RF field. Preferably, the measured intensity signal is compared to a target signal or radiation plan and a measure of the difference between the measured intensity signal and target signal is used to adjust the applied RF field in the RF cavity system 1810 in the extraction system to control the intensity of the protons in the extraction step. Stated again, the signal resulting from the protons striking and/or passing through the material 130 is used as an input in RF field modulation. An increase in the magnitude of the RF modulation results in protons hitting the foil or material 130 sooner. By increasing the RF, more protons are pushed into the foil, which results in an increased intensity, or more protons per unit time, of protons extracted from the synchrotron 130.

In another example, a detector 1850 external to the synchrotron 130 is used to determine the flux of protons extracted from the synchrotron and a signal from the external detector is used to alter the RF field or RF modulation in the RF cavity system 1810. Here the external detector generates an external signal, which is used in a manner similar to the measured intensity signal, described in the preceding paragraphs. Particularly, the measured intensity signal is compared to a desired signal from the irradiation plan 1860 in a feedback intensity controller 1840, which adjusts the RF field between the first plate 1812 and the second plate 1814 in the extraction process, described *supra*.

In yet another example, when a current from material 130 resulting from protons passing through or hitting material is measured beyond a threshold, the RF field modulation in the RF cavity system is terminated or reinitiated to establish a subsequent cycle of proton beam extraction. This process is repeated to yield many cycles of proton beam extraction from the synchrotron accelerator.

In still yet another embodiment, intensity modulation of the extracted proton beam is controlled by the main controller 110. The main controller 110 optionally and/or additionally controls timing of extraction of the charged particle beam and energy of the extracted proton beam.

The benefits of the system include a multi-dimensional scanning system. Particularly, the system allows independence in: (1) energy of the protons extracted and (2) intensity of the protons extracted. That is, energy of the protons extracted is controlled by an energy control system and an intensity control system controls the intensity of the extracted protons. The energy control system and intensity control system are optionally independently controlled. Preferably, the main controller 110 controls the energy control system and the main controller simultaneously controls the intensity control system to yield an extracted proton beam with controlled energy and controlled intensity where the controlled energy and controlled intensity are independently variable. Thus the irradiation spot hitting the tumor is under independent control of:

- time;
- energy;
- intensity;
- x-axis position, where the x-axis represents horizontal movement of the proton beam relative to the patient , and

- y-axis position, where the y-axis represents vertical movement of the proton beam relative to the patient.

In addition, the patient is optionally independently rotated relative to a translational axis of the proton beam at the same time.

Patient Positioning

Referring now to Figure 19, the patient is preferably positioned on or within a patient positioning system 1910 of the patient interface module 150. The patient positioning system 1910 is used to translate the patient and/or rotate the patient into a zone where the proton beam can scan the tumor using a scanning system 140 or proton targeting system, described *infra*. Essentially, the patient positioning system 1910 performs large movements of the patient to place the tumor near the center of a proton beam path 268 and the proton scanning or targeting system 140 performs fine movements of the momentary beam position 269 in targeting the tumor 1920. To illustrate, Figure 19 shows the momentary proton beam position 269 and a range of scannable positions 1940 using the proton scanning or targeting system 140, where the scannable positions 1940 are about the tumor 1920 of the patient 1930. This illustratively shows that the y-axis movement of the patient occurs on a scale of the body, such as adjustment of about 1, 2, 3, or 4 feet, while the scannable region of the proton beam 268 covers a portion of the body, such as a region of about 1, 2, 4, 6, 8, 10, or 12 inches. The patient positioning system and its rotation and/or translation of the patient combines with the proton targeting system to yield precise and/or accurate delivery of the protons to the tumor.

Referring still to Figure 19, the patient positioning system 1910 optionally includes a bottom unit 1912 and a top unit 1914, such as discs or a platform. Referring now to Figure 19A, the patient positioning unit 1910 is preferably y-axis adjustable 1916 to allow vertical shifting of the patient relative to the proton

therapy beam 268. Preferably, the vertical motion of the patient positioning unit 1910 is about 10, 20, 30, or 50 centimeters per minute. Referring now to Figure 19B, the patient positioning unit 1910 is also preferably rotatable 1917 about a rotation axis, such as about the y-axis, to allow rotational control and positioning of the patient relative to the proton beam path 268. Preferably the rotational motion of the patient positioning unit 1910 is about 360 degrees per minute. Optionally, the patient positioning unit rotates about 45, 90, or 180 degrees. Optionally, the patient positioning unit 1910 rotates at a rate of about 45, 90, 180, 360, 720, or 1080 degrees per minute. The rotation of the positioning unit 1917 is illustrated about the rotation axis at two distinct times, t_1 and t_2 . Protons are optionally delivered to the tumor 1920 at n times where each of the n times represent different directions of the incident proton beam 269 hitting the patient 1930 due to rotation of the patient 1917 about the rotation axis.

Any of the semi-vertical, sitting, or laying patient positioning embodiments described, *infra*, are optionally vertically translatable along the y-axis or rotatable about the rotation or y-axis.

Preferably, the top and bottom units 1912, 1914 move together, such that they rotate at the same rates and translate in position at the same rates. Optionally, the top and bottom units 1912, 1914 are independently adjustable along the y-axis to allow a difference in distance between the top and bottom units 1912, 1914. Motors, power supplies, and mechanical assemblies for moving the top and bottom units 1912, 1914 are preferably located out of the proton beam path 269, such as below the bottom unit 1912 and/or above the top unit 1914. This is preferable as the patient positioning unit 1910 is preferably rotatable about 360 degrees and the motors, power supplies, and mechanical assemblies interfere with the protons if positioned in the proton beam path 269

Proton Beam Position Control

Referring now to Figure 20, a beam delivery and tissue volume scanning system is illustrated. Presently, the worldwide radiotherapy community uses a method of dose field forming using a pencil beam scanning system. In stark contrast, Figure 20 illustrates a spot scanning system or tissue volume scanning system. In the tissue volume scanning system, the proton beam is controlled, in terms of transportation and distribution, using an inexpensive and precise scanning system. The scanning system is an active system, where the beam is focused into a spot focal point of about one-half, one, two, or three millimeters in diameter. The focal point is translated along two axes while simultaneously altering the applied energy of the proton beam, which effectively changes the third dimension of the focal point. The system is applicable in combination with the above described rotation of the body, which preferably occurs in-between individual moments or cycles of proton delivery to the tumor. Optionally, the rotation of the body by the above described system occurs continuously and simultaneously with proton delivery to the tumor.

For example, in the illustrated system in Figure 20A, the spot is translated horizontally, is moved down a vertical, and is then back along the horizontal axis. In this example, current is used to control a vertical scanning system having at least one magnet. The applied current alters the magnetic field of the vertical scanning system to control the vertical deflection of the proton beam. Similarly, a horizontal scanning magnet system controls the horizontal deflection of the proton beam. The degree of transport along each axes is controlled to conform to the tumor cross-section at the given depth. The depth is controlled by changing the energy of the proton beam. For example, the proton beam energy is decreased, so as to define a new penetration depth, and the scanning process is repeated along the horizontal and vertical axes covering a new cross-sectional area of the tumor. Combined, the three axes of control allow scanning or movement of the proton beam focal point over the entire volume of the

cancerous tumor. The time at each spot and the direction into the body for each spot is controlled to yield the desired radiation dose at each sub-volume of the cancerous volume while distributing energy hitting outside of the tumor.

The focused beam spot volume dimension is preferably tightly controlled to a diameter of about 0.5, 1, or 2 millimeters, but is alternatively several centimeters in diameter. Preferred design controls allow scanning in two directions with: (1) a vertical amplitude of about 100 mm amplitude and frequency up to 200 Hz; and (2) a horizontal amplitude of about 700 mm amplitude and frequency up to 1 Hz. More or less amplitude in each axis is possible by altering the scanning magnet systems.

In Figure 20A, the proton beam is illustrated along a z-axis controlled by the beam energy, the horizontal movement is along an x-axis, and the vertical direction is along a y-axis. The distance the protons move along the z-axis into the tissue, in this example, is controlled by the kinetic energy of the proton. This coordinate system is arbitrary and exemplary. The actual control of the proton beam is controlled in 3-dimensional space using two scanning magnet systems and by controlling the kinetic energy of the proton beam. The use of the extraction system, described *supra*, allows for different scanning patterns. Particularly, the system allows simultaneous adjustment of the x-, y-, and z-axes in the irradiation of the solid tumor. Stated again, instead of scanning along an x,y-plane and then adjusting energy of the protons, such as with a range modulation wheel, the system allows for moving along the z-axis while simultaneously adjusting the x- and or y-axes. Hence, rather than irradiating slices of the tumor, the tumor is optionally irradiated in three simultaneous dimensions. For example, the tumor is irradiated around an outer edge of the tumor in three dimensions. Then the tumor is irradiated around an outer edge of an internal section of the tumor. This process is repeated until the entire tumor is irradiated. The outer edge irradiation is preferably coupled with simultaneous

rotation of the subject, such as about a vertical y-axis. This system allows for maximum efficiency of deposition of protons to the tumor, as defined using the Bragg peak, to the tumor itself with minimal delivery of proton energy to surrounding healthy tissue.

Combined, the system allows for multi-axes control of the charged particle beam system in a small space with low power supply. For example, the system uses multiple magnets where each magnet has at least one edge focusing effect in each turning section of the synchrotron and/or multiple magnets having concentrating magnetic field geometry, as described *supra*. The multiple edge focusing effects in the circulating beam path of the synchrotron combined with the concentration geometry of the magnets and described extraction system yields a synchrotron having:

- a small circumference system, such as less than about 50 meters;
- a vertical proton beam size gap of about 2 cm;
- corresponding reduced power supply requirements associated with the reduced gap size;
- an extraction system not requiring a newly introduced magnetic field;
- acceleration or deceleration of the protons during extraction; and
- control of z-axis energy during extraction.

The result is a 3-dimensional scanning system, x-, y-, and z-axes control, where the z-axes control resides in the synchrotron and where the z-axes energy is variably controlled during the extraction process inside the synchrotron.

Referring now to Figure 20B, an example of a proton scanning or targeting system 140 used to direct the protons to the tumor with 4-dimensional scanning control is provided, where the 4-dimensional scanning control is along the x-, y-,

and z-axes along with intensity control, as described *supra*. A fifth axis is time. Typically, charged particles traveling along the transport path 268 are directed through a first axis control element 142, such as a vertical control, and a second axis control element 144, such as a horizontal control and into a tumor 1920. As described, *supra*, the extraction system also allows for simultaneous variation in the z-axis. Further, as describe, *supra*, the intensity or dose of the extracted beam is optionally simultaneously and independently controlled and varied. Thus instead of irradiating a slice of the tumor, as in Figure 20A, all four dimensions defining the targeting spot of the proton delivery in the tumor are simultaneously variable. The simultaneous variation of the proton delivery spot is illustrated in Figure 20B by the spot delivery path 269. In the illustrated case, the protons are initially directed around an outer edge of the tumor and are then directed around an inner radius of the tumor. Combined with rotation of the subject about a vertical axis, a multi-field illumination process is used where a not yet irradiated portion of the tumor is preferably irradiated at the further distance of the tumor from the proton entry point into the body. This yields the greatest percentage of the proton delivery, as defined by the Bragg peak, into the tumor and minimizes damage to peripheral healthy tissue.

Proton Energy and Intensity Control

Proton energy and intensity capabilities are provided. The proton delivery system is capable of beam acceleration up to an energy of at least 300 mega electron-Volt (MeV) and to a maximum energy of 330 MeV. Further illustrated is a flexible repeated acceleration and retardation of the proton beam in one cycle. Particularly, in a first cycle from the first to fourth seconds, the beam is accelerated to 100 MeV, retarded to 50 MeV and accelerated once more to 150 MeV. In the next cycle starting at the fifth second, the proton energy is increased rapidly to 330 MeV where it is maintained for one second, which is needed for carrying out tomography. The corresponding beam intensity is provided for the two serial cycles of the synchrotron accelerator's work. From approximately the

1½ to 3½ second marks, the beam is directed to a certain irradiating point. Upon achieving the necessary dose value, the extraction is interrupted, the beam is moved to the next point and the extraction process is resumed from the 5½ to 7½ second marks. In real time operation, each of the above described processes optionally are generated at ten times the illustrated rate.

IMAGING / X-RAY SYSTEM

Herein, an X-ray system is used to illustrate an imaging system.

Timing

An X-ray is preferably collected either (1) just before or (2) concurrently with treating a subject with proton therapy for a couple of reasons.

First, movement of the body, described *supra*, changes the local position of the tumor in the body relative to other body constituents. If the subject has an X-ray taken and is then bodily moved to a proton treatment room, accurate alignment of the proton beam to the tumor is problematic. Alignment of the proton beam to the tumor using one or more X-rays is best performed at the time of proton delivery or in the seconds or minutes immediately prior to proton delivery and after the patient is placed into a therapeutic body position, which is typically a fixed position or partially immobilized position.

Second, the X-ray taken after positioning the patient is used for verification of proton beam alignment to a targeted position, such as a tumor and/or internal organ position.

Positioning

An X-ray is preferably taken just before treating the subject to aid in patient positioning. For positioning purposes, an X-ray of a large body area is not needed. In one embodiment, an X-ray of only a local area is collected. When collecting an X-ray, the X-ray has an X-ray path. The proton beam has a proton beam path. Overlaying the X-ray path with the proton beam path is one method of aligning the proton beam to the tumor. However, this method involves putting the X-ray equipment into the proton beam path, taking the X-ray, and then moving the X-ray equipment out of the beam path. This process takes time. The elapsed time while the X-ray equipment moves has a couple of detrimental effects. First, during the time required to move the X-ray equipment, the body moves. The resulting movement decreases precision and/or accuracy of subsequent proton beam alignment to the tumor. Second, the time required to move the X-ray equipment is time that the proton beam therapy system is not in use, which decreases the total efficiency of the proton beam therapy system.

X-Ray Source Lifetime

It is desirable to have components in the particle beam therapy system that require minimal or no maintenance over the lifetime of the particle beam therapy system. For example, it is desirable to equip the proton beam therapy system with an X-ray system having a long lifetime source, such as a lifetime of about 20 years.

In one system, described *infra*, electrons are used to create X-rays. The electrons are generated at a cathode where the lifetime of the cathode is temperature dependent. Analogous to a light bulb, where the filament is kept in equilibrium, the cathode temperature is held in equilibrium at temperatures at about 200, 500, or 1000 degrees Celsius. Reduction of the cathode temperature results in increased lifetime of the cathode. Hence, the cathode used in

generating the electrons is preferably held at as low of a temperature as possible. However, if the temperature of the cathode is reduced, then electron emissions also decrease. To overcome the need for more electrons at lower temperatures, a large cathode is used and the generated electrons are concentrated. The process is analogous to compressing electrons in an electron gun; however, here the compression techniques are adapted to apply to enhancing an X-ray tube lifetime.

Patient Immobilization

Accurate and precise delivery of a proton beam to a tumor of a patient requires: (1) positioning control of the proton beam and (2) positioning control of the patient. As described, *supra*, the proton beam is controlled using algorithms and magnetic fields to a diameter of about 0.5, 1, or 2 millimeters. This section addresses partial immobilization, restraint, and/or alignment of the patient to insure the tightly controlled proton beam efficiently hits a target tumor and not surrounding healthy tissue as a result of patient movement.

Patient Placement

Preferably, the patient 1930 is aligned in the proton beam path 269 in a precise and accurate manner. In a first placement system, the patient is positioned in a known location relative to the platform. For example, one or more of the positioning constraints position the patient in a precise and/or accurate location on the platform. Optionally, a placement constraint element connected or replaceably connected to the platform is used to position the patient on the platform. The placement constraint element(s) is used to position any position of the patient, such as a hand, limb, head, or torso element.

Monitoring Breathing

Preferably, the patient's breathing pattern is monitored. When a subject, also referred to herein as a patient, is breathing many portions of the body move with each breath. For example, when a subject breathes the lungs move as do relative positions of organs within the body, such as the stomach, kidneys, liver, chest muscles, skin, heart, and lungs. Generally, most or all parts of the torso move with each breath. Indeed, the inventors have recognized that in addition to motion of the torso with each breath, various motion also exists in the head and limbs with each breath. Motion is to be considered in delivery of a proton dose to the body as the protons are preferentially delivered to the tumor and not to surrounding tissue. Motion thus results in an ambiguity in where the tumor resides relative to the beam path. To partially overcome this concern, protons are preferentially delivered at the same point in each of a series of breathing cycles.

Initially a rhythmic pattern of breathing of a subject is determined. The cycle is observed or measured. For example, a proton beam operator can observe when a subject is breathing or is between breaths and can time the delivery of the protons to a given period of each breath. Alternatively, the subject is told to inhale, exhale, and/or hold their breath and the protons are delivered during the commanded time period.

Preferably, one or more sensors are used to determine the breathing cycle of the individual. Two examples of a breath monitoring system are provided: (1) a thermal monitoring system and (2) a force monitoring system.

Breath Control

Once the rhythmic pattern of the subject's breathing is determined, a signal is optionally delivered to the subject to more precisely control the breathing frequency. For example, a display screen is placed in front of the subject

directing the subject when to hold their breath and when to breathe. Typically, a breathing control module uses input from one or more of the breathing sensors. For example, the input is used to determine when the next breath exhale is to complete. At the bottom of the breath, the control module displays a hold breath signal to the subject, such as on a monitor, via an oral signal, digitized and automatically generated voice command, or via a visual control signal. Preferably, a display monitor is positioned in front of the subject and the display monitor displays at least breathing commands to the subject. Typically, the subject is directed to hold their breath for a short period of time, such as about one-half, one, two, or three seconds. The period of time the subject is asked to hold their breath is less than about ten seconds. The period of time the breath is held is preferably synchronized to the delivery time of the proton beam to the tumor, which is about one-half, one, two, or three seconds. While delivery of the protons at the bottom of the breath is preferred, protons are optionally delivered at any point in the breathing cycle, such as upon full inhalation. Delivery at the top of the breath or when the patient is directed to inhale deeply and hold their breath by the breathing control module is optionally performed as at the top of the breath the chest cavity is largest and for some tumors the distance between the tumor and surrounding tissue is maximized or the surrounding tissue is rarefied as a result of the increased volume. Hence, protons hitting surrounding tissue is minimized. Optionally, the display screen tells the subject when they are about to be asked to hold their breath, such as with a 3, 2, 1, second countdown so that the subject is aware of the task they are about to be asked to perform.

Proton Beam Therapy Synchronization with Breathing

A proton delivery control algorithm is used to synchronize delivery of the protons to the tumor within a given period of each breath, such as at the top or bottom of a breath when the subject is holding their breath. The proton delivery control algorithm is preferably integrated with the breathing control module. Thus, the

proton delivery control algorithm knows when the subject is breathing, where in the breath cycle the subject is, and/or when the subject is holding their breath. The proton delivery control algorithm controls when protons are injected and/or inflected into the synchrotron, when an RF signal is applied to induce an oscillation, as described *supra*, and when a DC voltage is applied to extract protons from the synchrotron, as described *supra*. Typically, the proton delivery control algorithm initiates proton inflection and subsequent RF induced oscillation before the subject is directed to hold their breath or before the identified period of the breathing cycle selected for a proton delivery time. In this manner, the proton delivery control algorithm can deliver protons at a selected period of the breathing cycle by simultaneously or nearly simultaneously delivering the high DC voltage to the second pair of plates, described *supra*, which results in extraction of the protons from the synchrotron and subsequent delivery to the subject at the selected time point. Since the period of acceleration of protons in the synchrotron is constant or known for a desired energy level of the proton beam, the proton delivery control algorithm is used to set an AC RF signal that matches the breathing cycle or directed breathing cycle of the subject.

Multi-Field Illumination

The 3-dimensional scanning system of the proton spot focal point, described *supra*, is preferably combined with a rotation / raster method. The method includes layer wise tumor irradiation from many directions. During a given irradiation slice, the proton beam energy is continuously changed according to the tissue's density in front of the tumor to result in the beam stopping point, defined by the Bragg peak, to always be inside the tumor and inside the irradiated slice. The novel method allows for irradiation from many directions, referred to herein as multi-field irradiation, to achieve the maximal effective dose at the tumor level while simultaneously significantly reducing possible side-effects on the surrounding healthy tissues in comparison with existing methods.

Essentially, the multi-field irradiation system distributes dose-distribution at tissue depths not yet reaching the tumor.

Those skilled in the art will recognize that the present invention may be manifested in a variety of forms other than the specific embodiments described and contemplated herein. Departures in form and detail may be made without departing from the spirit and scope of the present invention. Accordingly, the invention should only be limited by the Claims included below.

CLAIMS

1. An apparatus for tumor therapy using charged particles, the charged particles accelerated by a rounded corner polygon synchrotron, said synchrotron comprising:

a center; and

a charged particle circulation beam path running;

about said center;

through straight sections; and

through turning sections,

wherein each of said turning sections comprises a plurality of bending magnets,

wherein said circulation beam path comprises a length of less than sixty meters, and

wherein a number of said straight sections equals a number of said turning sections.

2. The apparatus of Claim 1, further comprising:

a first focusing edge; a second focusing edge; a third focusing edge; and a fourth focusing edge,

wherein a first of said turning sections comprises a first bending magnet and a second bending magnet,

wherein said first bending magnets terminates on opposite sides with said first focusing edge and said second focusing edge,

wherein a first plane established by said first focusing edge intersects a plane established by said second focusing edge beyond said center of said synchrotron,

wherein said second bending magnets terminates on opposite sides with said third focusing edge and said fourth focusing edge,

wherein a second plane established by said third focusing edge intersects a plane established by said fourth focusing edge beyond said center of said synchrotron,

wherein all of said first focusing edge; said second focusing edge; said third focusing edge; and said fourth focusing edge bend the charged particles toward said center of said synchrotron.

3. The apparatus of Claim 2, wherein at least two of said plurality of bending magnets further comprise a magnetic field focusing section, said focusing section comprising:

a geometry tapering from a first cross-sectional area to a second cross-sectional area, said second cross-sectional area comprising less than two-thirds of an area of said first cross-sectional area, said second cross-sectional area proximate said charged particle beam path.

4. The apparatus of Claim 3, wherein said geometry carries a magnetic field during use, wherein the magnetic field concentrates in density from said first cross-sectional area to said second-cross-sectional area.

5. The apparatus of Claim 4, wherein said second cross-sectional area comprises a flat surface, said flat surface comprising about a zero to three microns polish.

6. The apparatus of Claim 1, wherein said turning sections each comprise at least four bending magnets, said four bending magnets comprising at least eight edge focusing surfaces, wherein geometry of said edge focusing surfaces

focuses the charged particles in said charged particle circulation beam path during use.

7. The apparatus of Claim 1, wherein each of said turning sections turns the charged particles by about ninety degrees.

8. The apparatus of Claim 7, wherein each of said turning sections comprises at least four focusing edges, wherein geometry of said focusing edges yield an edge focusing effect on the charged particles.

9. The apparatus of Claim 8, said bending magnets comprising a tapered core, said tapered core comprising a first cross-section distance at least one and a half times longer than a second cross-section distance, said second cross-section distance proximate a gap, said gap having a surface polish of less than about ten microns roughness, said charged particle circulation beam path running through said gap.

10. The apparatus of Claim 1, wherein said number of turning sections comprises exactly four turning sections, wherein each of said four turning sections turns the charged particle circulation beam path about ninety degrees, said synchrotron capable of accelerating the charged particles to at least 300 MeV.

11. The apparatus of Claim 10, wherein said four turning sections comprise at least thirty-two charged particle edge focusing surfaces.

12. The apparatus of Claim 1, wherein said turning sections comprise at least eight bending magnets, wherein said charged particle circulation beam path does not pass through any operational quadrupole magnets.

13. The apparatus of Claim 1, each of said turning magnets comprising:
a gap, said charged particle beam path running through said gap, and
a core, wherein said core terminates at said gap with a surface comprising a finish of less than about ten microns polish.

14. The apparatus of Claim 13, further comprising:
a winding coil winding about said core; and
a correction coil winding about said core, wherein said correction coil operates at less than three percent of the power of said winding coil.

15. The apparatus of Claim 14, further comprising:
an extraction control algorithm, said extraction control algorithm receiving input generated by a current originating at an extraction foil, said extraction foil proximate said charged particle circulation beam path, said extraction control algorithm comparing a feedback input to an irradiation plan, said extraction control algorithm adjusting a radio-frequency field in a radio-frequency cavity system.

16. The apparatus of Claim 1, wherein at least one of said turning magnets further comprises:

a gap through which said charged particle circulation beam path runs; and
an amplifier geometry, wherein said amplifier geometry concentrates a magnetic field approaching said gap.

17. The apparatus of Claim 16, further comprising:

a magnetic winding comprising a coil wrapped around at least two of said turning magnets; and

a correction winding comprising a correction coil wrapped about said at least two of said turning magnets, wherein said correction winding operates at less than three percent of the power of said magnetic winding.

18. The apparatus of Claim 1, further comprising:

a winding coil, wherein a turn in said coil wraps around at least two of said turning magnets, wherein said turn does not occupy space directly between said at least two of said turning magnets.

19. The apparatus of Claim 18, further comprising:

a correction coil wrapped about said at least two turning magnets, wherein said correction coil comprises a turn that does not occupy space directly between said at least two of said turning magnets, wherein said correction coil operates at less than three percent of the power of said winding coil.

20. The apparatus of Claim 1, further comprising:

a negative ion source, said negative ion source producing negative ions in a negative ion beam;

an ion beam focusing lens focusing the negative ion beam; and

a converting foil, said converting foil converting the negative ion beam into the charged particles.

21. The apparatus of Claim 20, wherein said lens comprises field lines running, in a vacuum system, through the negative ion beam, wherein the field lines focus the negative ion beam, said ion beam focusing lens further comprising:

a first focusing electrode circumferentially surrounding the negative ion beam; and

a second focusing electrode comprising metal conductive paths at least partially blocking the negative ion beam,

wherein first electric field lines run between said first focusing electrode and said second focusing electrode, and

wherein the negative ions encounter first force vectors running up the first electric field lines that focus the negative ion beam.

22. The apparatus of Claim 21, wherein said metal conductive paths comprise any of:

a series of conductive lines running substantially in parallel across the negative ion beam;

a conductive grid crossing the negative ion beam; and

a focusing foil crossing the negative ion beam, said focusing foil having holes, said holes comprising a combined cross-sectional area of at least ninety percent of the cross-sectional area of the negative ion beam.

23. The apparatus of Claim 20, wherein said converting foil converts the negative ions into the charged particles, wherein said converting foil provides a vacuum barrier between said negative ion source and said charged particle circulation beam path.

24. The apparatus of Claim 20, wherein said converting foil provides a pressure seal between said ion beam focusing lens and said turning sections, wherein a first pump system operates to maintain a first vacuum within said ion beam focusing lens, wherein a second pump system operates to maintain a second vacuum in said charged particle circulation beam path.

25. The apparatus of Claim 20, wherein said negative ion source further comprises a magnetic field barrier separating a high energy plasma region from a low temperature plasma zone.

26. The apparatus of Claim 20, wherein said converting foil comprises:

a beryllium carbon film, wherein said carbon film comprises a thickness of about thirty to two hundred micrometers, wherein said carbon film forms a vacuum barrier between said negative ion source and said plurality of turning magnets.

27. The apparatus of Claim 1, wherein said synchrotron further comprises:

an extraction material;

at least a one kilovolt direct current field applied across a pair of extraction blades; and

a deflector,

wherein the charged particles pass through said extraction material resulting in reduced energy charged particles,

wherein the reduced energy charged particles pass between said pair of extraction blades,

wherein the direct current field redirects the reduced energy charged particles out of said synchrotron through said deflector, and

wherein said deflector yields an extracted charged particle beam.

28. The apparatus of Claim 27, further comprising an intensity controller controlling intensity of the extracted charged particles via a feedback control.

29. The apparatus of Claim 28, wherein an induced current results from the charged particles passing through said extraction material, wherein the induced current comprises said feedback input to said intensity controller.

30. A method for tumor therapy using charged particles, the charged particles accelerated by a rounded corner polygon synchrotron, said method comprising the step of:

accelerating the charged particles in a charged particle circulation beam path running about a center of said synchrotron, said charged particle circulation beam path comprising:

straight sections; and

turning sections,

wherein each of said turning sections comprises a plurality of bending magnets,

wherein said circulation beam path comprises a length of less than sixty meters, and

wherein a number of said straight sections equals a number of said turning sections.

31. The method of Claim 1, further comprising the step of:

bending the charged particles toward said center of said synchrotron using all of a first focusing edge, a second focusing edge, a third focusing edge, and a fourth focusing edge,

wherein a first of said turning sections comprises a first bending magnet and a second bending magnet,

wherein said first bending magnets terminates on opposite sides with said first focusing edge and said second focusing edge,

wherein a first plane established by said first focusing edge intersects a plane established by said second focusing edge beyond said center of said synchrotron,

wherein said second bending magnets terminates on opposite sides with said third focusing edge and said fourth focusing edge, and

wherein a second plane established by said third focusing edge intersects a plane established by said fourth focusing edge beyond said center of said synchrotron.

32. The method of Claim 31, further comprising the step of:

focusing the charged particles using at least two of said plurality of bending magnets that further comprise a magnetic field focusing section, said focusing section comprising:

a geometry tapering from a first cross-sectional area to a second cross-sectional area, said second cross-sectional area comprising less than two-thirds of an area of said first cross-sectional area, said second cross-sectional area proximate said charged particle beam path, wherein said geometry carries a magnetic field during use, wherein the magnetic field concentrates in density from said first cross-sectional area to said second-cross-sectional area.

33. The method of Claim 32, wherein said second cross-sectional area comprises a flat surface, said flat surface comprising about a zero to three microns polish.

34. The method of Claim 30, further comprising the step of:

focusing the charged particles in said charged particle circulation beam path during use with edge focusing surfaces having focusing geometry, wherein said turning sections each comprise at least four bending magnets, said four bending magnets comprising at least eight surfaces having said focusing geometry.

35. The method of Claim 30, further comprising the step of:

turning the charged particles about ninety degrees with each of said turning sections.

36. The method of Claim 35, wherein each of said turning sections comprises at least four focusing edges, wherein geometry of said focusing edges yield an edge focusing effect on the charged particles.

37. The method of Claim 9, said bending magnets comprising a tapered core, said tapered core comprising a first cross-section distance at least one and a half times longer than a second cross-section distance, said second cross-section distance proximate a gap, said gap having a surface polish of less than about ten microns roughness, said charged particle circulation beam path running through said gap.

38. The method of Claim 30, further comprising the steps of:

accelerating the charged particles to at least 300 MeV using said synchrotron, wherein said number of turning sections comprises exactly four turning sections; and

turning the charge particles about ninety degrees with each of said four turning sections.

39. The method of Claim 38, wherein said four turning sections comprise at least thirty-two charged particle edge focusing surfaces.

40. The method of Claim 30, wherein said turning sections comprise at least eight bending magnets, wherein said charged particle circulation beam path does not pass through any operational quadrupole magnets.

41. The method of Claim 30, further comprising the step of:

running the charged particles through a gap, said gap running through each of said turning magnets, said gap comprising a surface finish of less than about ten microns polish, wherein each of said turning magnets comprises a core terminating at said gap.

42. The method of Claim 41, further comprising the step of:

operating a correction coil at less than three percent of the power of a winding coil, said winding coil running about said core, said correction coil winding about said core.

43. The method of Claim 42, further comprising the steps of:

an extraction control algorithm comparing an input to an irradiation plan;
and

said extraction control algorithm adjusting a radio-frequency in a radio-frequency cavity system, said input comprising a current originating at an extraction foil when the charged particles in said charged particle circulation beam path transmit through said extraction foil.

44. The method of Claim 30, further comprising the step of:

concentrating a magnetic field approaching a gap using a tapering core geometry, said charged particle circulation beam path running through said gap, said gap present within said bending magnets.

45. The method of Claim 44, further comprising the step of:

operating a correction coil at less than three percent of the power of a winding coil, said winding coil comprising a single winding wrapped around at least two of said turning magnets; said correction coil comprising a single winding wrapped about said at least two of said turning magnets.

46. The method of Claim 30, further comprising the steps of:

generating a negative ion beam using a negative ion source;

focusing the negative ion beam using an ion beam focusing lens; and

converting the negative ion beam at a converting foil into the charged particles.

47. The method of Claim 46, wherein said lens comprises field lines running through the negative ion beam, wherein the field lines focus the negative ion beam, said ion beam focusing lens further comprising:

a first focusing electrode circumferentially surrounding the negative ion beam; and

a second focusing electrode comprising metal conductive paths at least partially blocking the negative ion beam,

wherein first electric field lines run between said first focusing electrode and said second focusing electrode, and

wherein the negative ions encounter first force vectors running up the first electric field lines that focus the negative ion beam.

48. The method of Claim 46, further comprising the step of:

creating a vacuum barrier using said converting foil between said negative ion source and said charged particle circulation beam path.

49. The method of Claim 46, further comprising the steps of:

providing a pressure seal between said ion beam focusing lens and said turning sections using said converting foil;

maintaining a first vacuum within said ion beam focusing lens; and

maintaining a second vacuum within said charged particle circulation beam path, wherein said second vacuum comprises a stronger vacuum than said first vacuum.

50. The method of Claim 46, further comprising the step of:

maintaining a magnetic field barrier in said negative ion source between a high energy plasma region and a low temperature plasma zone.

51. The method of Claim 46, further comprising the step of:

forming a vacuum barrier between said negative ion source and said plurality of turning magnets with said converting foil,

wherein said converting foil consists essentially of atoms having six or fewer protons, and

wherein said film comprises a thickness of about thirty to two hundred micrometers.

52. The method of Claim 30, further comprising the step of:

passing the charged particles through said extraction material resulting in reduced energy charged particles; and

applying at least a one kilovolt direct current field across a pair of extraction blades,

wherein the reduced energy charged particles pass between said pair of extraction blades, and

wherein the direct current field redirects the reduced energy charged particles out of said synchrotron through a deflector resulting in extracted charged particles.

53. The method of Claim 52, further comprising the step of:

controlling intensity of the extracted charged particles using an intensity controller and a feedback control.

54. The method of Claim 53, wherein said feedback control includes an induced current input resulting from said step of passing the charged particles through said extraction material.

1/18

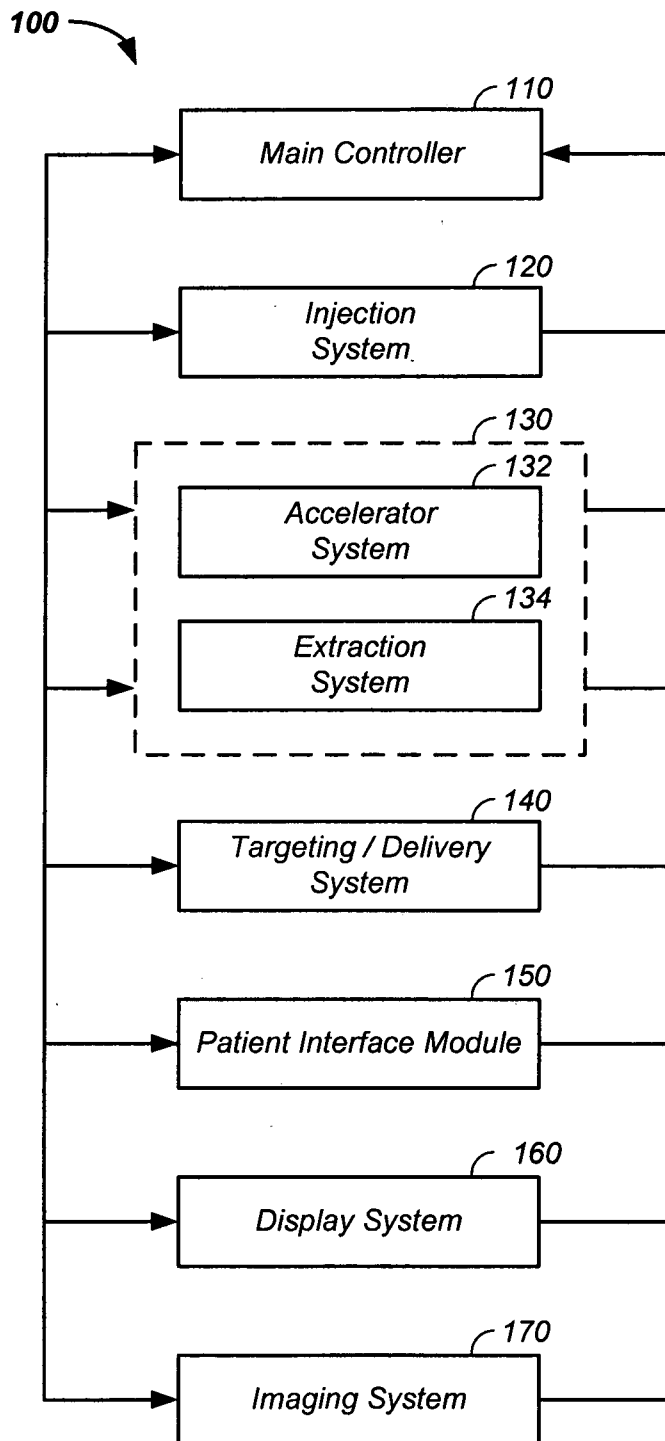

FIG. 1

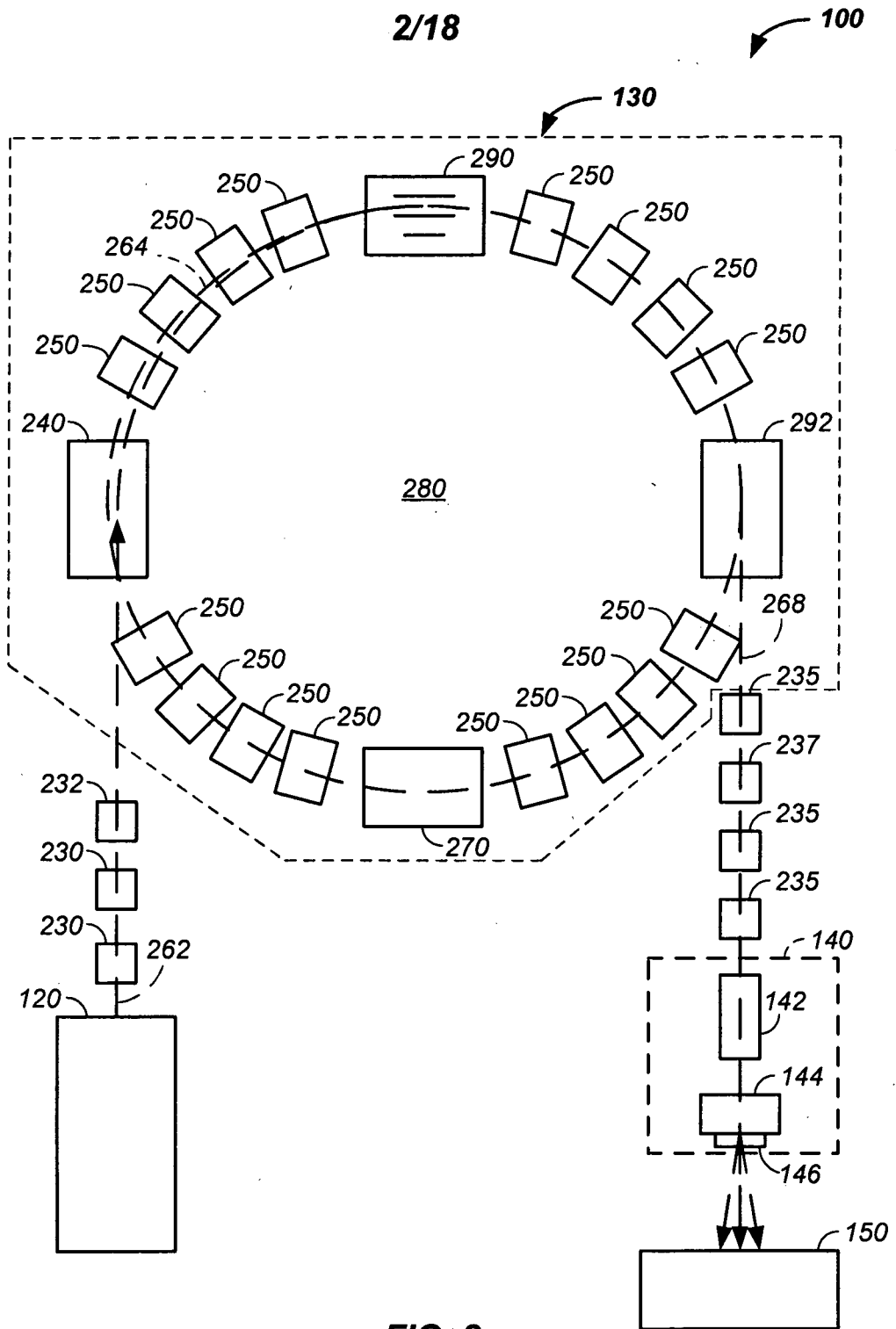

FIG. 2

3/18

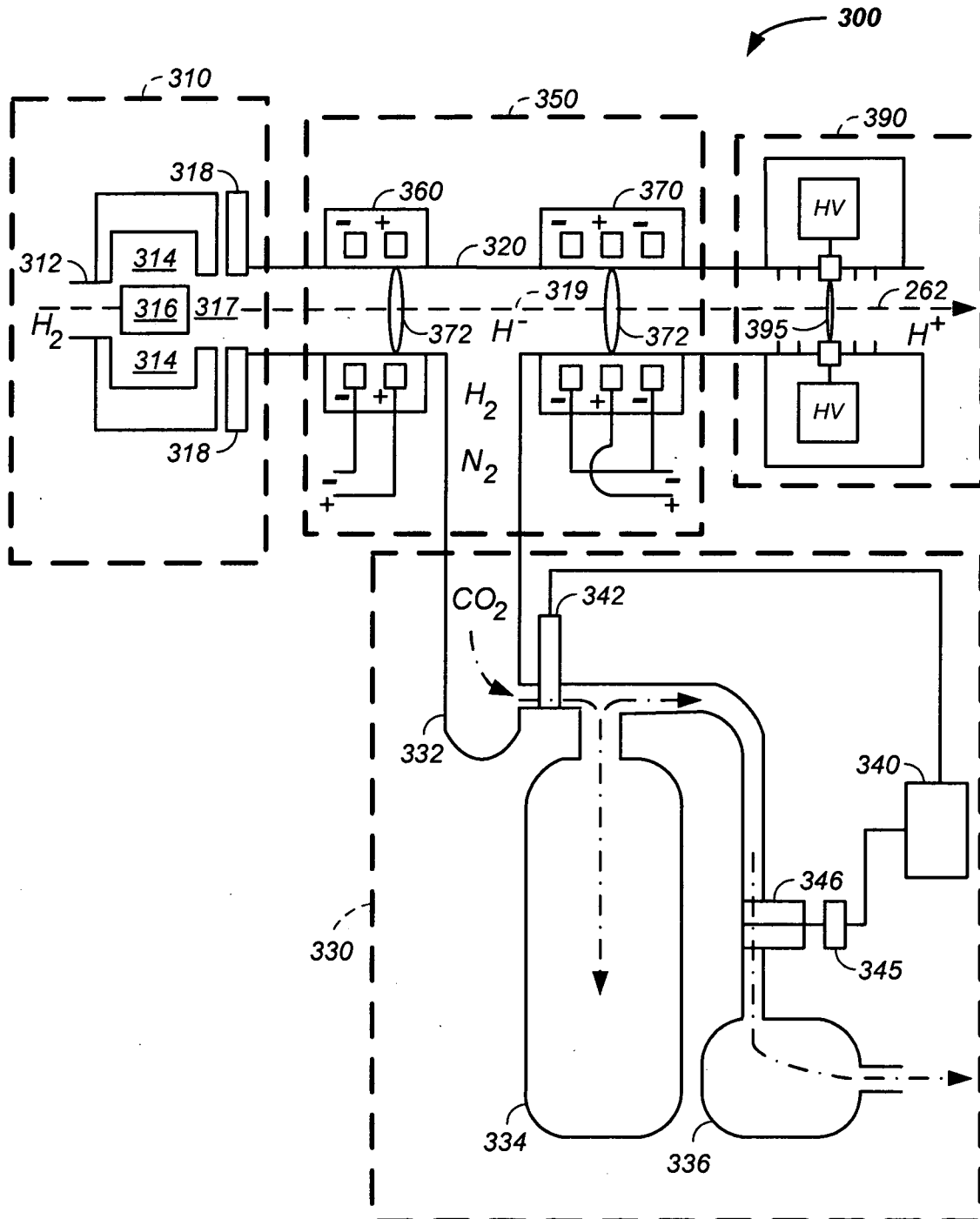

FIG. 3

4/18

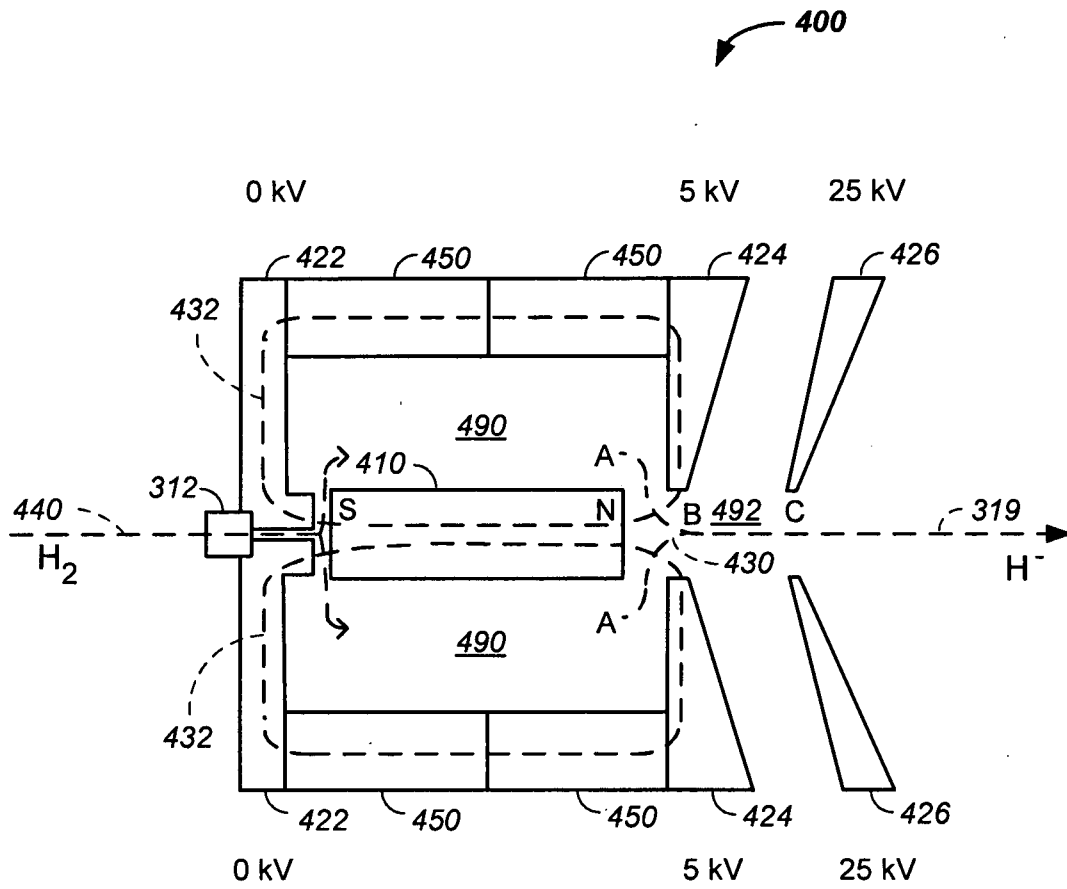

FIG. 4

5/18

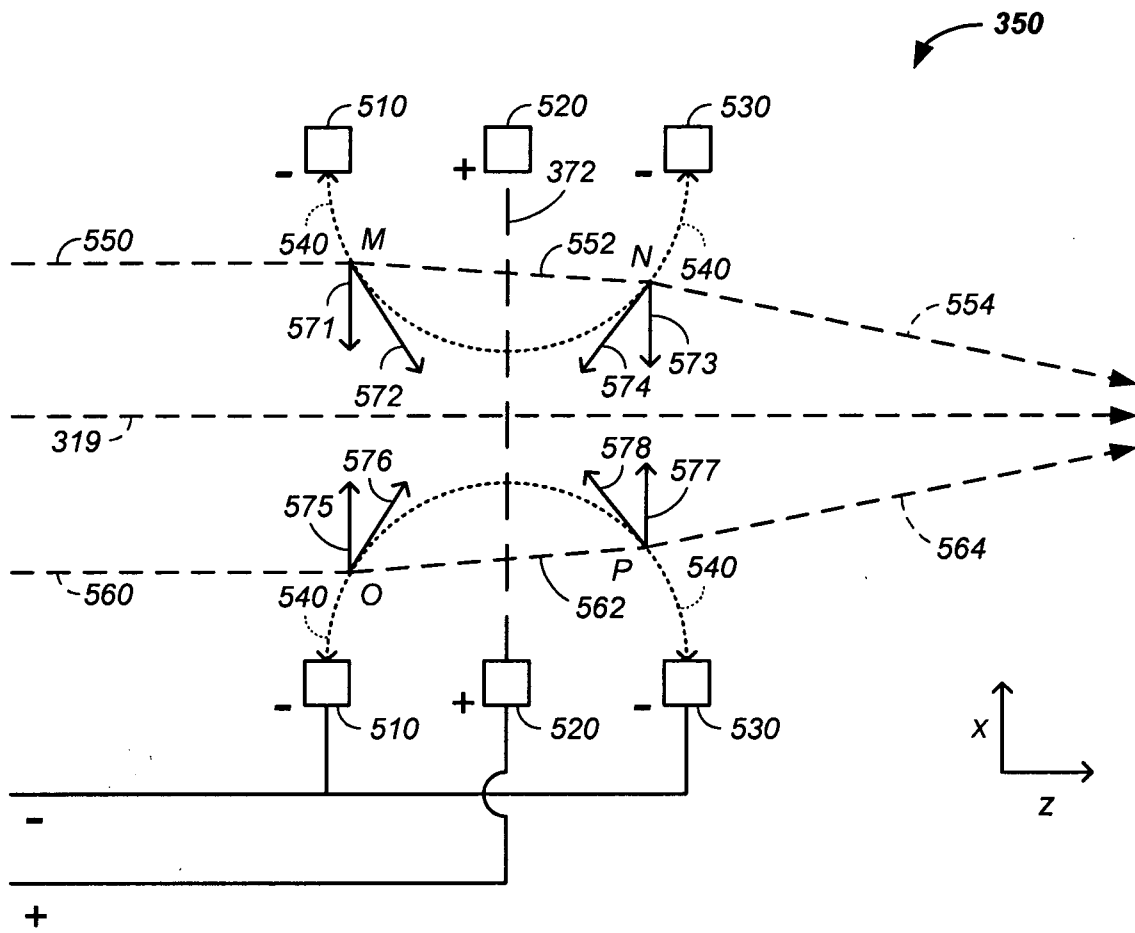

FIG. 5

6/18

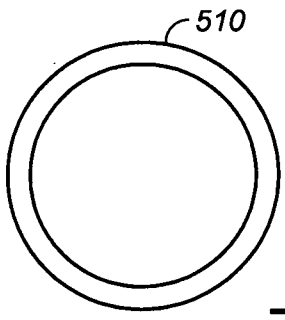

FIG. 6A

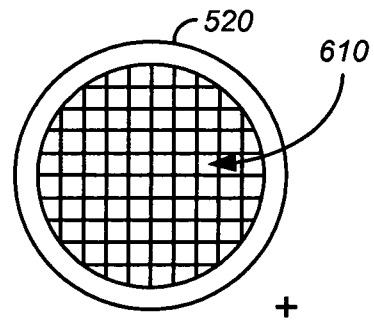

FIG. 6B

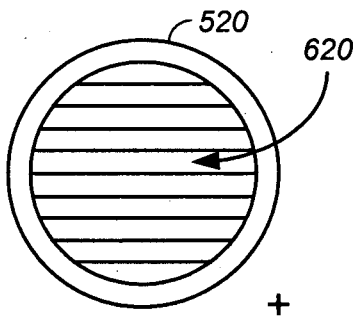

FIG. 6C

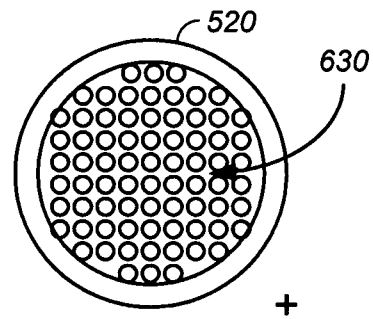

FIG. 6D

7/18

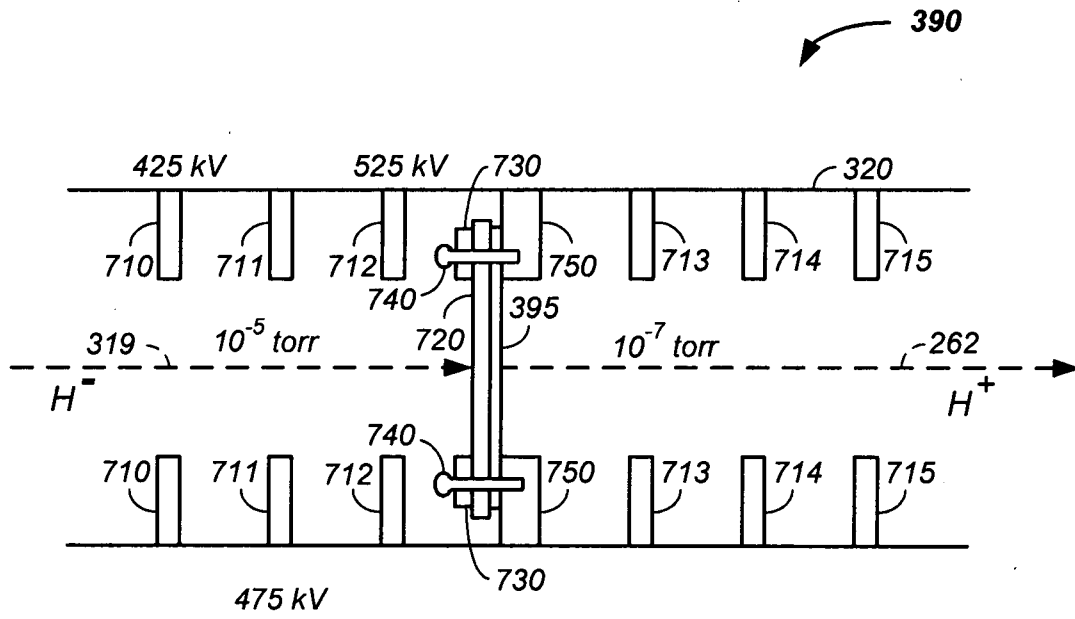

FIG. 7A

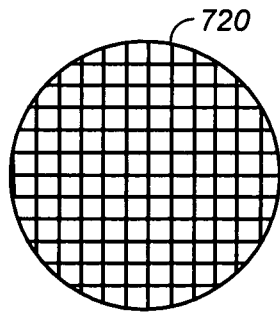

FIG. 7B

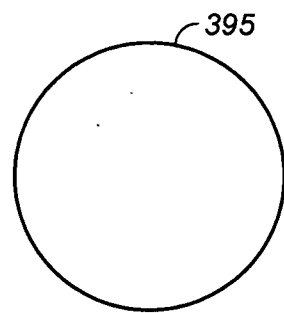

FIG. 7C

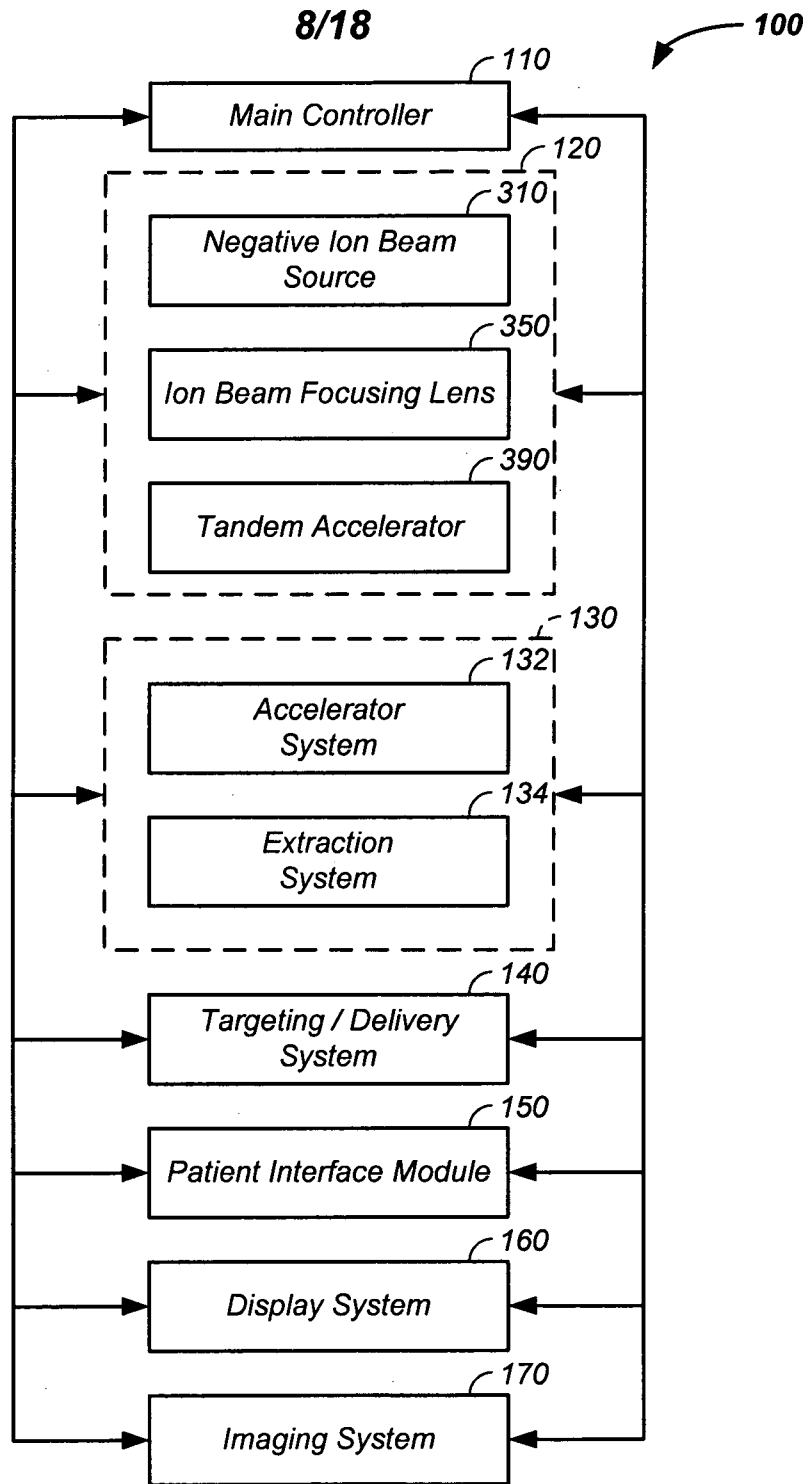

FIG. 8

9/18

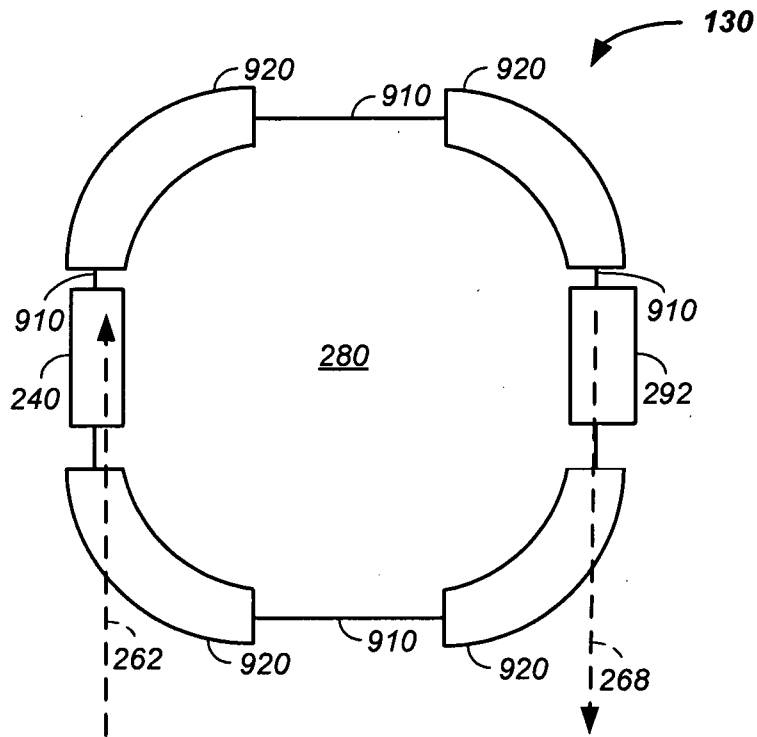

FIG. 9

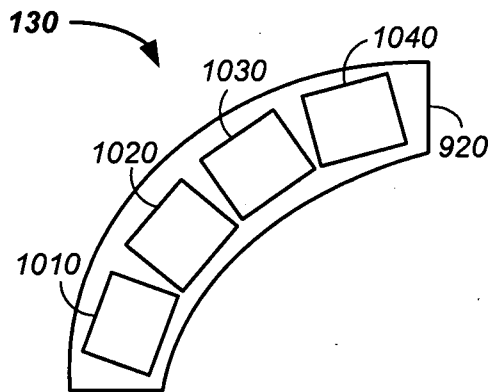
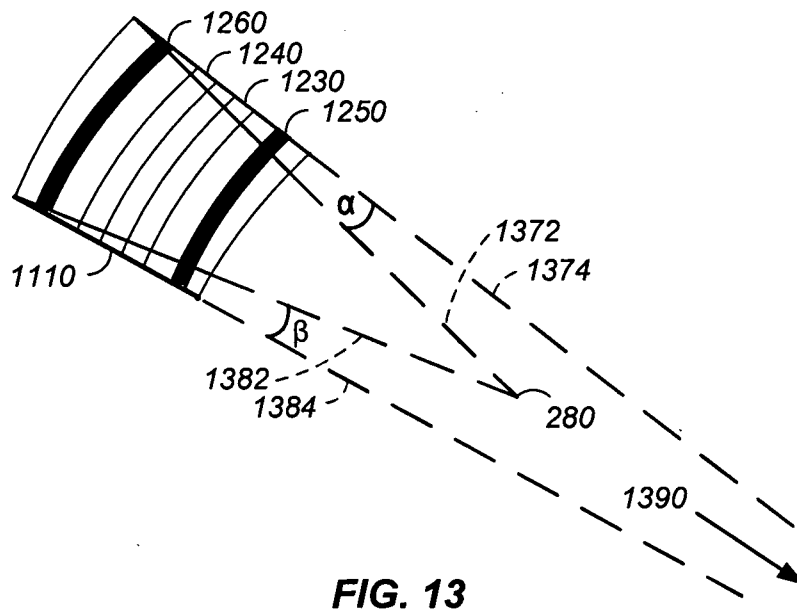
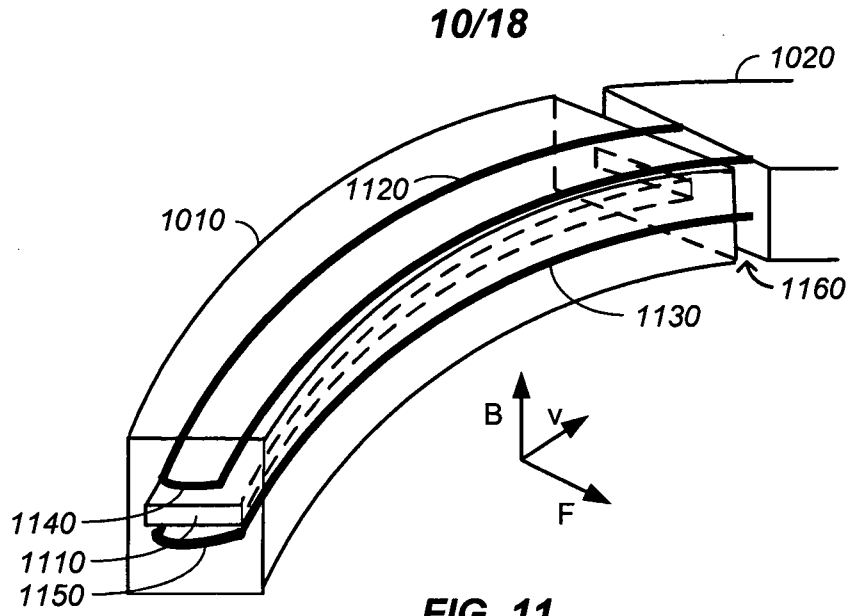

FIG. 10



11/18

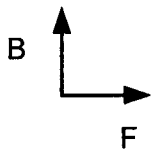
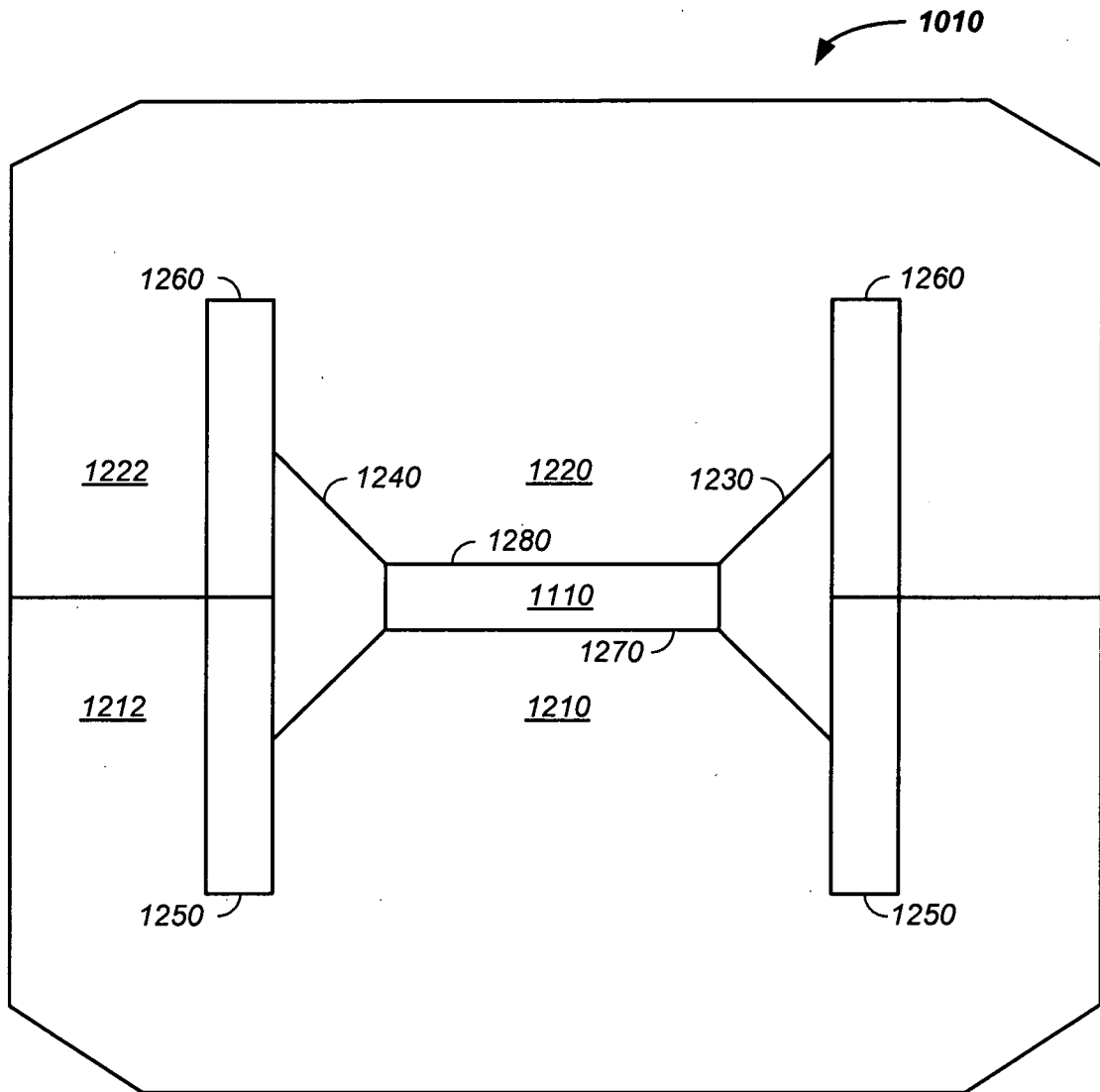

FIG. 12

12/18

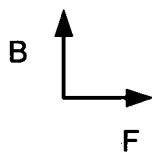
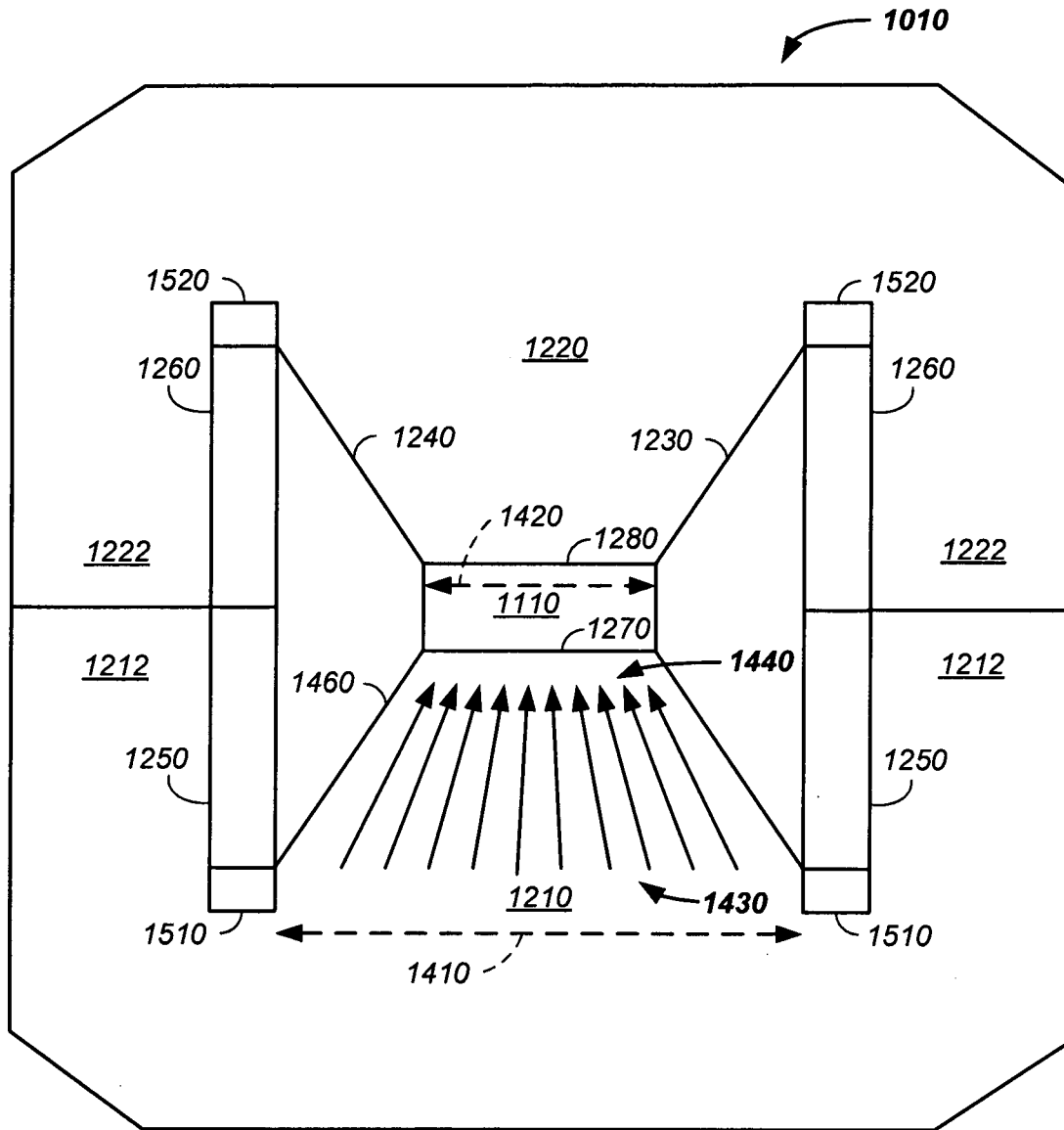

FIG. 14

13/18

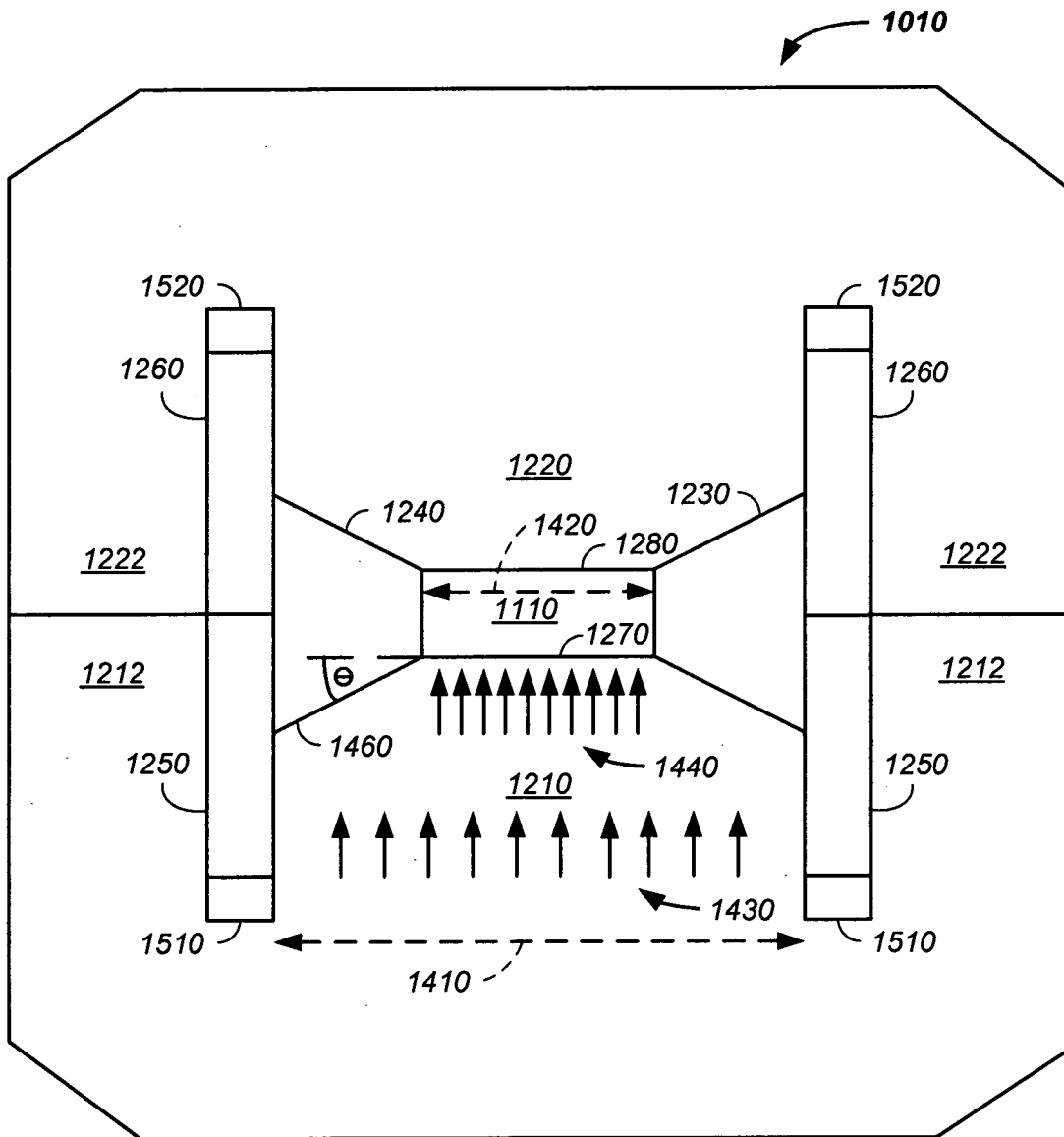

FIG. 15

14/18

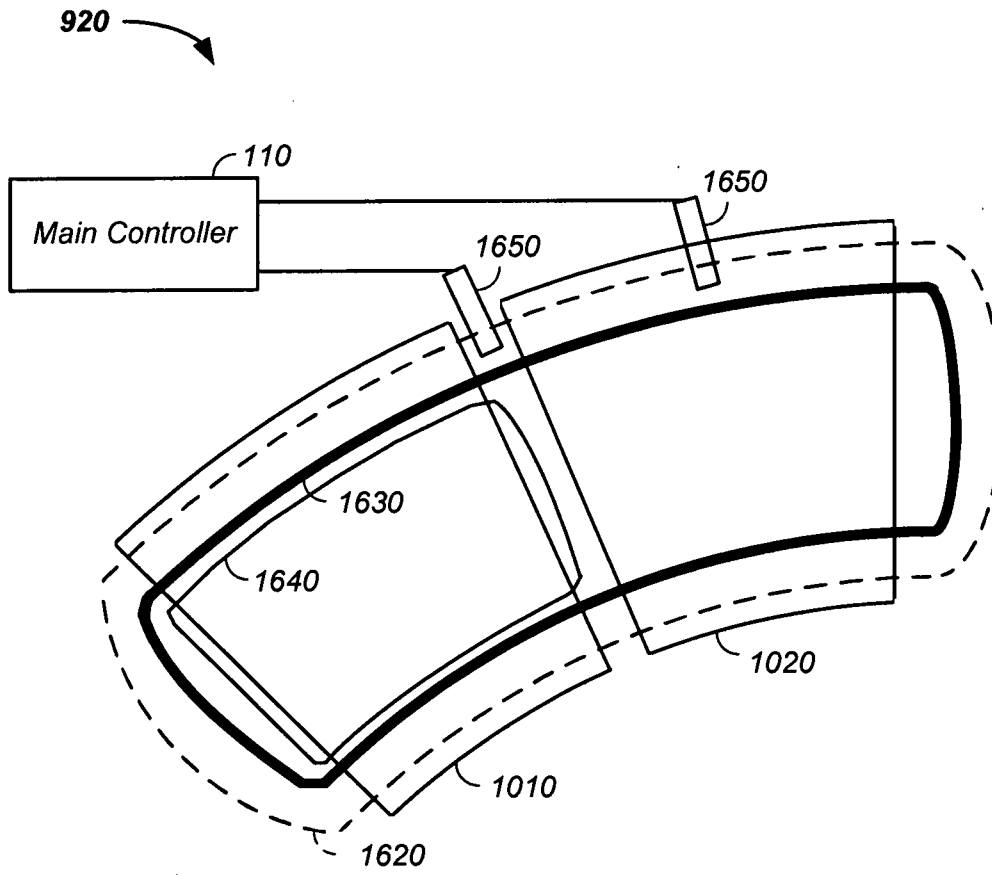

FIG. 16

15/18

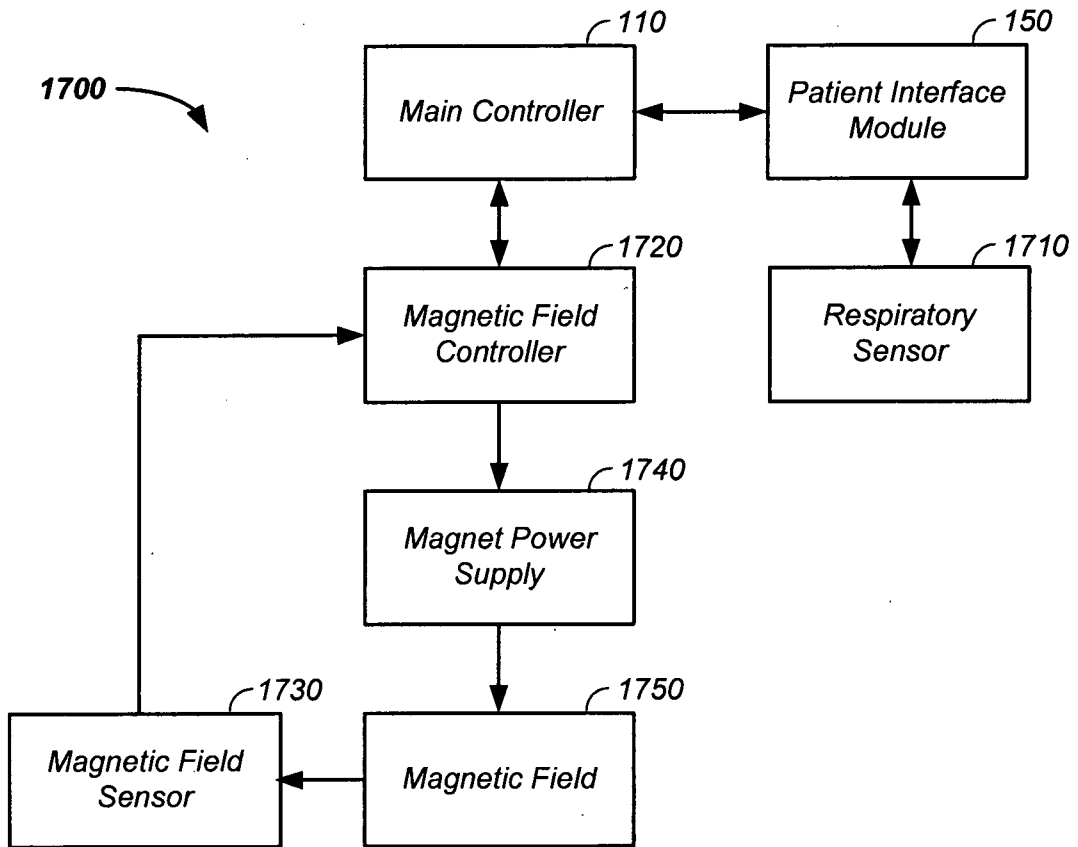

FIG. 17

16/18

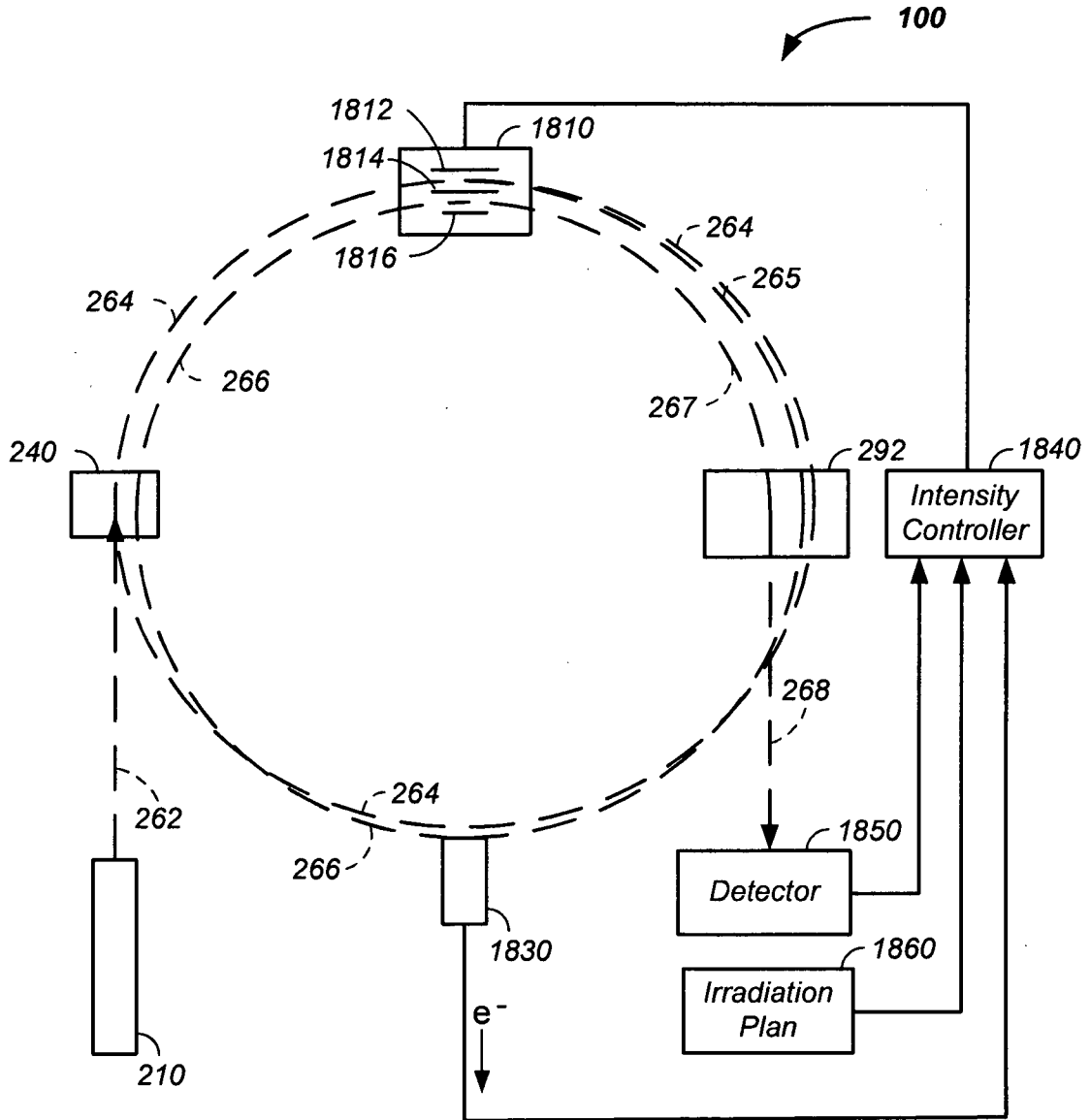

FIG. 18

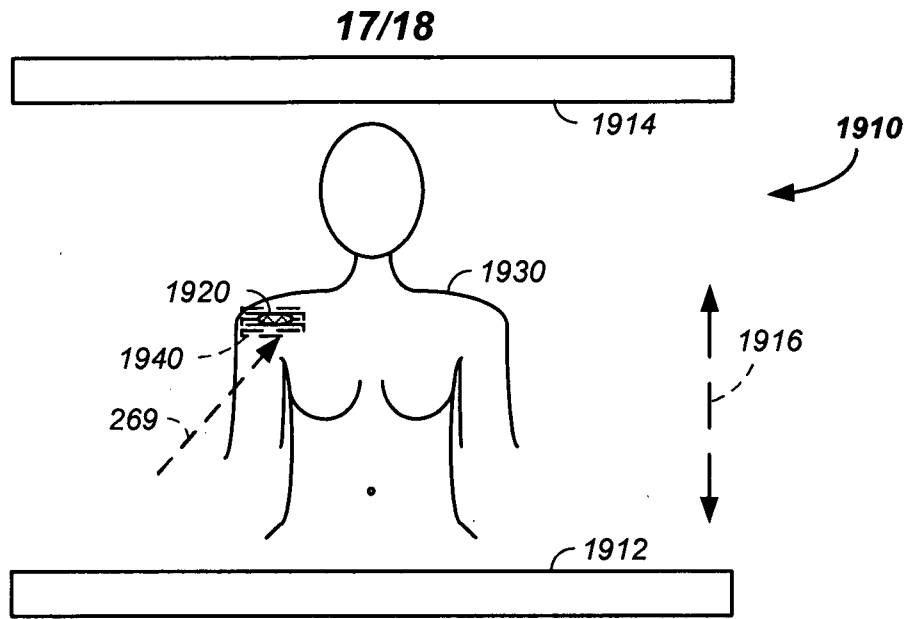

FIG. 19A

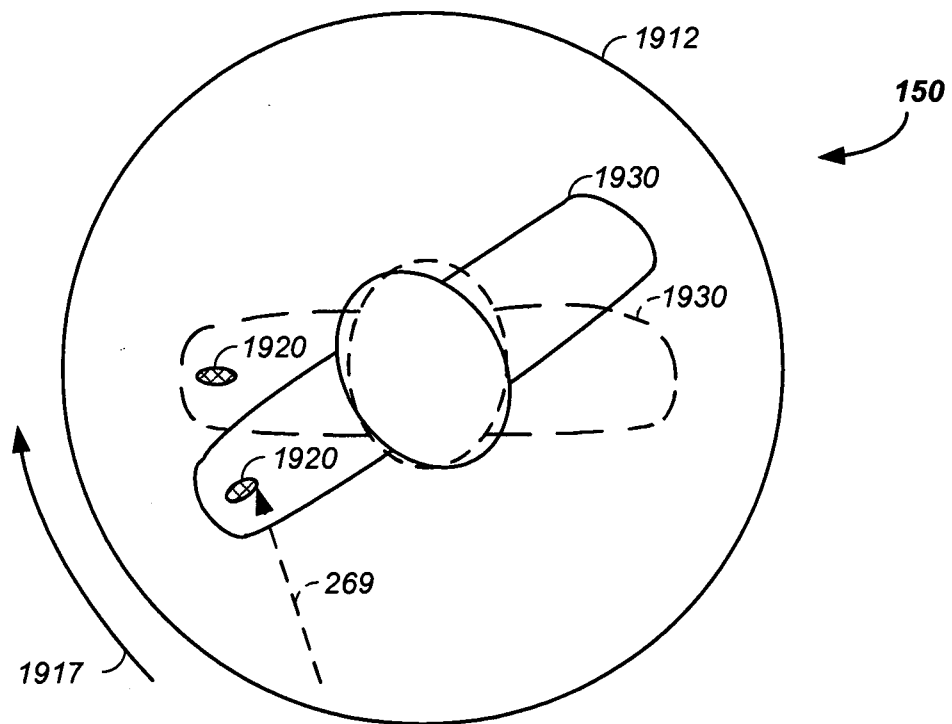

FIG. 19B

