



Europäisches Patentamt  
European Patent Office  
Office européen des brevets



(11) **EP 0 890 323 A2**

(12) **EUROPEAN PATENT APPLICATION**

(43) Date of publication:  
13.01.1999 Bulletin 1999/02

(51) Int. Cl.<sup>6</sup>: **A43C 3/02**

(21) Application number: **98201231.2**

(22) Date of filing: **17.04.1998**

(84) Designated Contracting States:  
**AT BE CH CY DE DK ES FI FR GB GR IE IT LI LU  
MC NL PT SE**  
Designated Extension States:  
**AL LT LV MK RO SI**

(72) Inventor: **Zanata, Francesco**  
**31030 Biadene di Montebelluna (Treviso) (IT)**

(74) Representative:  
**Cantaluppi, Stefano et al**  
**c/o JACOBACCI & PERANI S.p.A.**  
**Via Berchet, 9**  
**35131 Padova (IT)**

(30) Priority: **11.07.1997 IT PD970155**

(71) Applicant: **Zanata S.p.A.**  
**31030 Biadene di Montebelluna (Treviso) (IT)**

(54) **A lacing cleat**

(57) A lacing cleat for a laced fastening comprises a first and a second cheek (4, 5) which are disposed side by side and between which a channel (6) is defined, and a pin-shaped appendage (10) extending between the cheeks (4, 5) and optionally equipped with an idle pulley (21) for defining a lacing surface.

**FIG. 2**

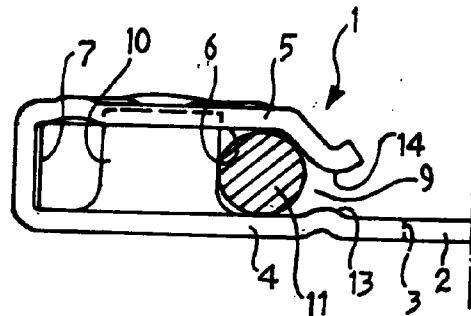

## Description

The present invention relates to a lacing cleat for a laced fastening comprising a first and a second cheek which are disposed side by side and between which a channel is defined. It is known to make footwear with a laced fastening in which the lace is guided through suitable cleats. The surfaces of known cleats offer a certain friction to the sliding of the lace, making it very difficult to fasten the lace of the fastening with the desired force.

A primary object of the present invention is to provide lacing cleats which are designed structurally and functionally to offer less friction to the sliding of the lace.

Another object of the invention is to provide a cleat which can restrain the lace once it is engaged in the channel. A further object is to provide a cleat which, whilst achieving the advantages set out above, can be produced at low cost.

One of the chief objects of the invention is to provide a cleat which is particularly strong and permits both conventional lacing and lacing with a purchase effect, and which is suitable for clamping the lace.

These and other objects described in detail below are achieved by a lacing cleat formed in accordance with the following claims.

The characteristics and advantages of the invention will become clearer from the following detailed description of two preferred embodiments thereof, given by way of non-limiting example, with reference to the appended drawings, in which:

Figures 1 and 2 are a plan view and a longitudinal section, respectively, of a first embodiment of the lacing cleat according to the invention,

Figures 3 and 4 are views of a second embodiment of the lacing cleat according to the invention, corresponding to Figures 1 and 2, respectively,

Figure 5 shows a possible use of the cleats of the preceding drawings.

In Figures 1 and 2, a first embodiment of a lacing cleat formed in accordance with the present invention is generally indicated 1. The cleat 1 comprises an attachment plate 2 through which one or more holes 3 extend and by which the cleat is attached to a respective flap 3a, 3b of a footwear upper (Figure 5) by means of rivets 3c or the like.

The plate 2 is extended to form a first and a second cheek 4, 5 which jointly define a channel 6 closed by an end portion 7 and open at the opposite end, that is, at an opening 9.

A cylindrical, pin-like appendage 10 extends between the cheeks 4, 5 and is preferably formed by drawing of the central region of the first cheek 4 towards the second cheek 5.

The appendage 10 has a tubular shape, open at both axial ends, and preferably opens beyond the second cheek 5 in the region of a hole 10a thereof, without,

however, any mechanical connection between the end of the appendage 10 and the second cheek.

The surface of the end 7 of the channel 6 and the opposite surface of the appendage 10 define, respectively, a second and a first lacing surface on which a lace 11 can be guided for sliding as described further below.

A narrow section is formed at the opening 9 of the channel 6 and is defined by the two cheeks 4, 5 which have, respectively, a projection 13 and a lip 14 facing one another and projecting towards the interior of the channel 6 in order to restrict its opening. This narrow section constitutes a restraining means for holding the lace 11 against the first lacing surface of the appendage 10 once it is engaged in the cleat 1.

It should be pointed out that, since the cheeks 4, 5 are connected to one another solely at the end 7 of the channel 6, they have a limited ability to move apart resiliently which, together with the resilient deformability of the lace, allows the latter to pass through the opening 9 of the channel 6 in order to be engaged in the cleat 1 where it remains held until it is forced out of the channel. Once the lace is arranged for lacing, it therefore remains in its position of engagement in the cleats until it is deliberately removed.

Finally, it should be noted that the second cheek 5 has a plurality of reinforcing ribs 15 projecting in relief towards the inside of the channel 6, towards the other cheek 4. The ribs 15 extend approximately radially relative to the axis of the appendage 10.

With reference now to Figures 3 and 4, a second embodiment of the cleat formed in accordance with the present invention is indicated 20. Details similar to those of the previous embodiment are labelled with the same reference numerals.

Unlike the cleat 1, the cleat 20 has a pulley 21 mounted idly on the appendage 10 which, in this embodiment, constitutes the pin of the pulley. The first lacing surface is therefore defined on the race 22 of the pulley 21. The sliding friction between the lace and the cleat is thus transformed into rolling friction, further improving the ability of the lace to slide.

It should be noted that, in the embodiment 20, there is a single hole 3 in the attachment plate 2. The cleat is thus mounted on the corresponding flap of the upper by a single rivet 3c, permitting limited orientation of the cleat under load. It should be understood that both of the embodiments proposed may be provided with attachment plates with one or more holes according to need.

In normal use, a lace 11 is engaged in the cleat 1 or 20 through the opening 9 so as to bear in sliding contact on the first lacing surface defined on the appendage 10 or on the race of the pulley 21, respectively. If it is desired to achieve a greater tightening load for a given tension applied to the ends of the lace and, at the same time, a clamping of the lace, in terms of greater resistance offered to the release of the lacing, the lace 11 can

be passed through the lacing cleats in the manner shown in Figure 5. Typically, this solution is implemented in the pairs of cleats which enclose the instep of the foot. The lace coming from the lower portion or toe of the footwear is first inserted against the end surface 7 of the channel 6 of one of the cleats 20 and is then passed over the appendage 10 or pulley 21 of the opposite cleat 20. A connection with purchase is thus achieved between the cleats and amplifies the tightening and clamping force, or opposes the release of the lace under load. The invention thus achieves the purposes and advantages indicated.

### Claims

1. A lacing cleat for a laced fastening, comprising a first and a second cheek (4, 5) which are disposed side by side and between which a channel (6) is defined, characterized in that it comprises a pin-shaped appendage (10) extending between the cheeks and defining a first lacing surface on its side opposite an end surface (7) of the channel (6). 5
2. A lacing cleat according to Claim 1, in which the channel (6) is open at the opposite end to the said end surface (7). 10
3. A lacing cleat according to Claim 1 or Claim 2, in which the appendage (10) is spaced from the end surface (7) of the channel (6), the end surface defining a second lacing surface. 15
4. A lacing cleat according to any one of Claims 1 to 3, in which a pulley (21) is mounted rotatably on the pin-shaped appendage (10). 20
5. A lacing cleat according to one or more of the preceding claims, in which the pin-shaped appendage (10) is cylindrical and hollow. 25
6. A lacing cleat according to one or more of the preceding claims, in which the pin-shaped appendage (10) is formed integrally with one of the cheeks (4, 5), for example, by drawing of the cheek towards the opposite cheek. 30
7. A lacing cleat according to one or more of the preceding claims, in which at least one of the cheeks (4, 5) has a plurality of reinforcing ribs (15) projecting towards the opposite cheek. 35
8. A lacing cleat according to Claim 7, in which the ribs (15) extend approximately radially relative to the axis of the appendage (10). 40
9. A lacing cleat according to one or more of the preceding claims, in which a first (4) of the cheeks is formed integrally with a plate (2) for the attachment of the cleat to a footwear upper, the ribs (15) being formed in the second cheek (5). 45
10. A lacing cleat according to one or more of the preceding claims, in which the cheeks (4, 5) define restraining means for holding the lace in the channel (6). 50
11. A lacing cleat according to Claim 10, in which the restraining means comprise a narrow section at the opening (9) of the channel. 55
12. A lacing cleat according to Claim 11, in which the narrow section is defined by at least one lip-like element (14) at the free end of the second cheek (5).
13. A lacing cleat according to Claim 11 or Claim 12, in which the narrow section is defined by a projection (13) in the first cheek (4).
14. A lacing cleat according to Claim 13, in which the projection (13) and the lip-like element (14) face one another in the channel (6).
15. A lacing cleat according to one or more of the preceding claims, in which the cheeks (4, 5) can be moved apart resiliently, the appendage (10) extending from one cheek to the other but being free relative to one of the cheeks.

FIG. 1

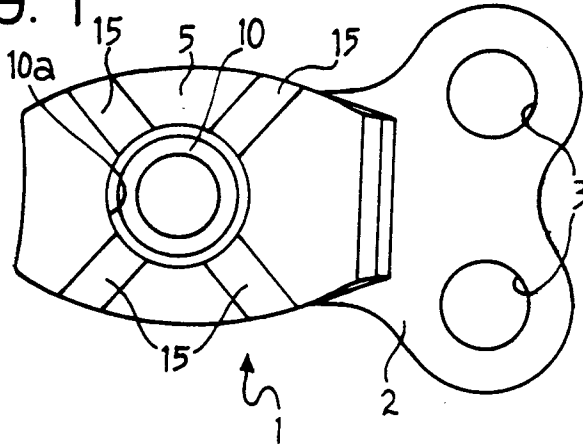

FIG. 2

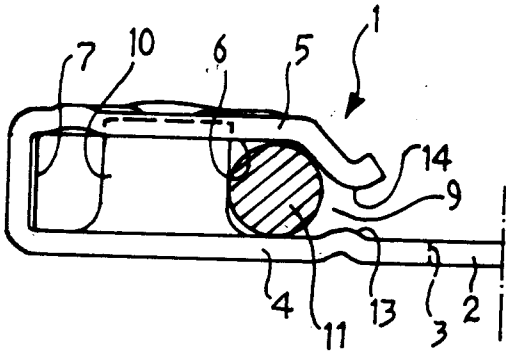

FIG. 3

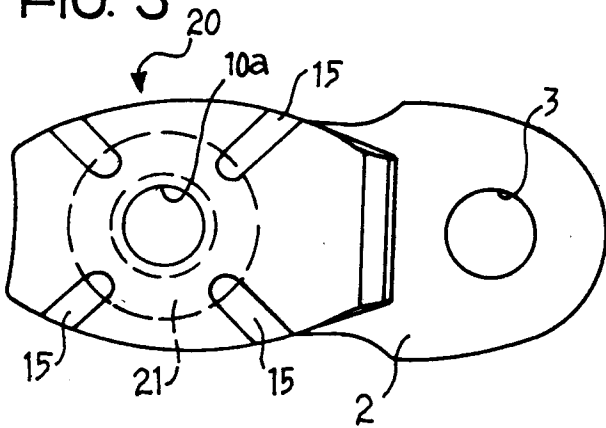

FIG. 4

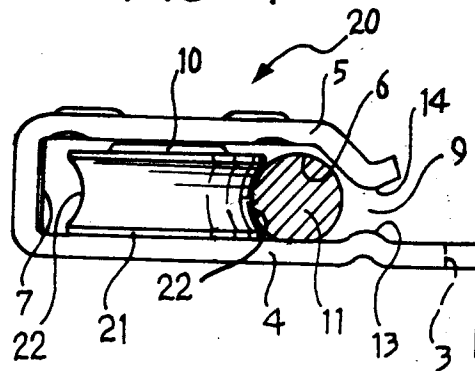

FIG. 5

