

19



Europäisches Patentamt
European Patent Office
Office européen des brevets



11 Publication number:

0 351 375 B1

12

EUROPEAN PATENT SPECIFICATION

- 45 Date of publication of patent specification: **22.09.93** 51 Int. Cl.⁵: **G05G 1/14, F16K 31/62, A61C 1/04**
- 21 Application number: **89830282.3**
- 22 Date of filing: **20.06.89**

54 **Compact pneumatic pedal assembly.**

30 Priority: **13.07.88 IT 2159088 U**

43 Date of publication of application:
17.01.90 Bulletin 90/03

45 Publication of the grant of the patent:
22.09.93 Bulletin 93/38

84 Designated Contracting States:
AT BE CH DE ES FR GB LI NL

56 References cited:
DD-A- 226 348
DE-A- 3 129 355
US-A- 4 612 954

73 Proprietor: **STEELCONTROL S.r.l.**
Via Trieste, 103
I-20064 Gorgonzola (Milano)(IT)

72 Inventor: **Sorba, Renzo Steelcontrol S.r.l.**
Via Trieste, 103
I-20064 - Gorgonzola (Milano)(IT)

74 Representative: **Cicogna, Franco**
Ufficio Internazionale Brevetti Dott.Prof.
Franco Cicogna Via Visconti di Modrone,
14/A
I-20122 Milano (IT)

EP 0 351 375 B1

Note: Within nine months from the publication of the mention of the grant of the European patent, any person may give notice to the European Patent Office of opposition to the European patent granted. Notice of opposition shall be filed in a written reasoned statement. It shall not be deemed to have been filed until the opposition fee has been paid (Art. 99(1) European patent convention).

Description

BACKGROUND OF THE INVENTION

The present invention relates to an improved pneumatic pedal assembly.

As is known pedal driving assemblies are frequently used for small size or micro motors, for example for the dentistry field and goldsmith's art, as well as in washing machines.

The valves used for controlling servovalves are however of comparatively great size (from 1/8" to 1/4") or they are paired or pair coupled, that is one pneumatic valve associated with an electric valve.

Moreover in prior apparatus of the above mentioned type, a pedal usually controls a remote control switch in turn controlling the driving coil of a servocontrol operating either a cylinder or another cylinder of a two cylinder operating assembly.

The document DE-A-31 29 355 discloses a pneumatic pedal assembly having substantially the features of the pre-characterizing portion of the main claim.

SUMMARY OF THE INVENTION

The present invention sets out to overcome the above mentioned drawbacks, by providing a pedal control assembly bypassing the electric aspect or elements of a control of the above mentioned type and which operates on servocontrol coils or solenoids by pneumatically operating on said servocontrol.

Within the scope of the above aim, a main object of the present invention is to provide such a pedal assembly which comprises exclusively pneumatic component thereby reducing to a minimum the making cost and maintenance and repairing requirements.

Another object of the invention is to provide such a control pedal assembly specifically designed for washing machines.

According to one aspect of the present invention, the above aim and objects, as well as yet other objects, which will become more apparent hereinafter, are achieved by a pneumatic pedal assembly, having the features of the characterizing part of the main claim.

BRIEF DESCRIPTION OF THE DRAWINGS

Further characteristics and advantages of the invention will become more apparent hereinafter from the following description of a preferred embodiment thereof, which is illustrated, by way of an indicative but not limitative example, in the figures of the accompanying drawing, where:

figure 1 is a schematic view illustrating a control pedal assembly with the casing mounted on the pedal element and valve body;

figures 2 and 3 are cross-sectional views showing a control pedal assembly including a normally closed 3-way valve body and a 5-way valve body with M5 fitting respectively;

figures 4 and 5 are front views respectively illustrating a control pedal assembly with a 3-way valve body and protected M5 fitting and a quick coupled 5-way valve body.

DESCRIPTION OF THE PREFERRED EMBODIMENT

With reference to the figures of the accompanying drawings, the control pedal assembly according to the present invention comprises a reduced size casing, indicated at the reference number 1, a pedal element 2 and either a 3-way or a 5-way valve body.

In the illustrated embodiment 3 of the 3-way valve body, either of the normally opened or normally closed type, and in the embodiment indicated at 4 of 5-way valve, there is included a quick type of fitting, indicated at 5, or a M5 type of fitting indicated at 5'.

The control pedal assembly according to the present invention is specifically provided for actuating a pneumatic servo-control in which the operating fluid, for example filtered and lubricated air, efficiently operates through the overall required temperature and pressure range, depending on the preset passage diameter and cross-section.

The casing 1 is preferably made of a black galvanized sheet metal, passivated against corrosion, and in the bottom of said casing there are formed threaded holes 6 for receiving screws for connecting the control pedal assembly to the machine to be controlled.

According to a preferred embodiment, the valve body 7 is made of anodized aluminium, whereas the spool member 8 is made of processed brass, the gaskets 9 being of conventional type.

It should be apparent that the subject control pedal assembly can be provided with a protective cover 10 (fig.4).

Claims

1. A pneumatic pedal assembly for controlling small size motors in dentistry apparatus, goldsmith's apparatus, washing machines and the like, comprising a substantially parallelepipedal casing supporting on a major face thereof a depressible pedal (2) of substantially rectangular shape, a pneumatic valve body (7) fixed inside said casing to be directly actuated by

said pedal (2), characterized in that said pneumatic valve body (7) is an anodized aluminium valve body fixed to a minor face of said casing (1), to said body (7) there being coupled an extending brass valve spool member (8) to be directly actuated by said pedal (2), and in that fitting means (5, 5') communicating with said valve body (7) are associated with said same minor face of said casing.

2. An assembly according to Claim 1, characterized in that said pneumatic valve body (7) is a 3-way valve body.
3. An assembly according to Claim 1, characterized in that said pneumatic valve body is a 5-way valve body.
4. An assembly according to Claim 1, characterized in that said fitting means (5, 5') comprise a quick type of fitting (5).
5. An assembly according to Claim 1, characterized in that said fitting means (5, 5') comprise a M5 type of fitting.

Patentansprüche

1. Pneumatisch gesteuerte Pedalvorrichtung zum Steuern von keinen Motoren innerhalb zahnärztlicher Geräte, Goldschmiedgeräte, Waschmaschinen und dergleichen, mit einem wesentlich Parallelepipedförmigen Kastenkörper, der, auf seine grössere Seite, ein druckbare Pedal, das eine wesentlich rechteckige Form weist auf, und einen Körper (7) eines pneumatischen Ventil, stützt, der um durch das obengenannte Pedal (2) direkt angetrieben werden, innerhalb des obengenannten Kastenkörpers befestigt wird, dadurch gekennzeichnet, dass der obengenannte Körper (7) eines pneumatischen Ventils einen Ventilkörper aus eloxiertem Aluminium ist, wobei dieser Körper auf die kleinere Seite des obengenannten Kastenkörpers (1) befestigt wird, wobei mit dem obengenannten Körper (7) ein sich erstreckende Spulenelement (8) eines Kupferventils gekoppelt wird, um durch das obengenannte Pedal (2) direkt angetrieben werden, und dass Zubehörteile (5, 5'), die mit dem obengenannten Ventilkörper (7) kommunizieren, mit derselben obengenannten kleineren Seite des obengenannten Kastenkörpers verbunden sind.
2. Vorrichtung nach Anspruch 1, dadurch gekennzeichnet, dass der obengenannte pneumatische Ventilkörper (7) einen 3-wegeventil ist.

3. Vorrichtung nach Anspruch 1, dadurch gekennzeichnet, dass der obengenannte pneumatische Ventilkörper einen 5-wegeventil ist.

5 4. Vorrichtung nach Anspruch 1, dadurch gekennzeichnet, dass die obengenannten Zubehörteile (5, 5') mit einem Zubehör (5) schneller Art versehen ist.

10 5. Vorrichtung nach Anspruch 1, dadurch gekennzeichnet, dass die obengenannten Zubehörteile (5, 5') mit einem M5-artigen Zubehör versehen ist.

15 Revendications

1. Dispositif de pédale à commande pneumatique pour contrôler les moteurs d'une mesure réduite dans les appareils d'odontologie, dans les appareils d'orfèvrerie, dans les machines à laver et similaires, comprenant une boîte essentiellement en forme d'un parallélépipède, supportant sur sa face la plus grande une pédale (2) pouvant être pressée et ayant une forme essentiellement rectangulaire, un corps de valve pneumatique (7) qui est fixé à l'intérieur de ladite boîte en vue d'être actionné directement par ladite pédale (2), caractérisé en ce que ledit corps (7) de valve pneumatique est un corps de valve fait d'aluminium anodisé, qui est fixé à la face la plus petite de ladite boîte (1), audit corps (7) il y étant accouplé un élément (8) étendu en forme de bobine pour la valve, en laiton, en vue d'être actionné directement par ladite pédale (2), et en ce que des éléments accessoires (5, 5') se trouvant en communication avec ledit corps (7) de valve, sont associés avec ladite face la plus petite de ladite boîte.

2. Dispositif selon la revendication 1, caractérisé en ce que ledit corps (7) de valve pneumatique est un corps de valve à trois-voies.

45 3. Dispositif selon la revendication 1, caractérisé en ce que ledit corps de valve pneumatique est un corps de valve à 5 voies.

50 4. Dispositif selon la revendication 1, caractérisé en ce que lesdits éléments accessoires (5, 5') comprennent un type rapide d'accessoire (5).

55 5. Dispositif selon la revendication 1, caractérisé en ce que lesdits éléments accessoires (5, 5') comprennent un type M5 d'accessoire.

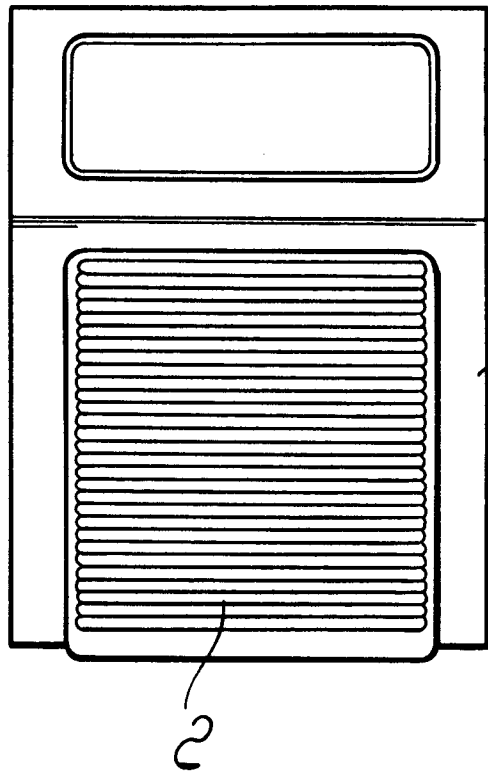

Fig. 1

Fig. 2

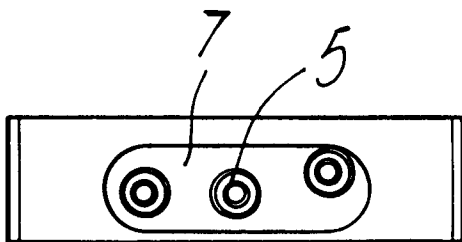
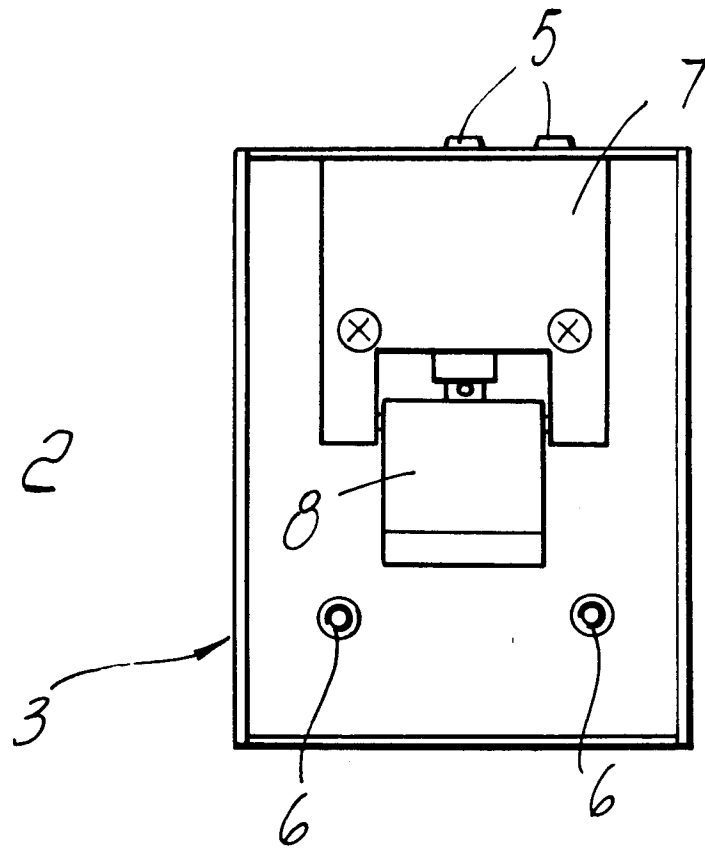

Fig. 5

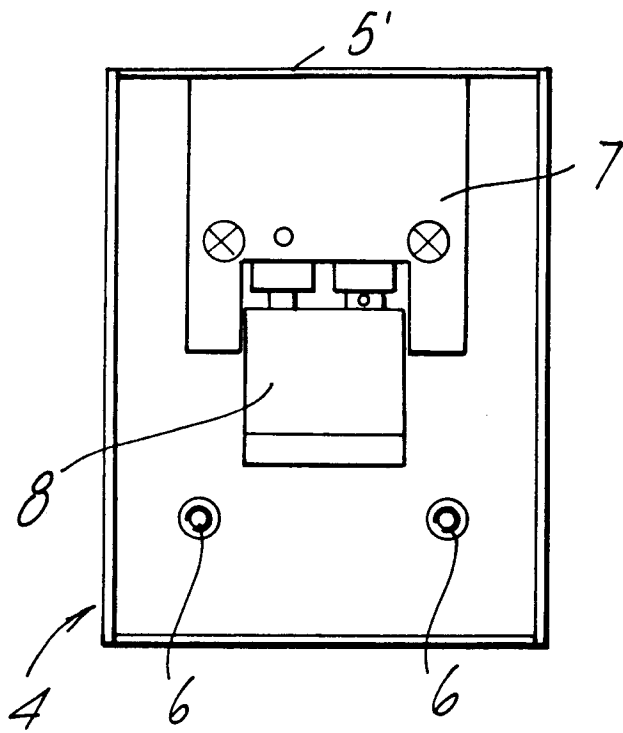

FIG. 3

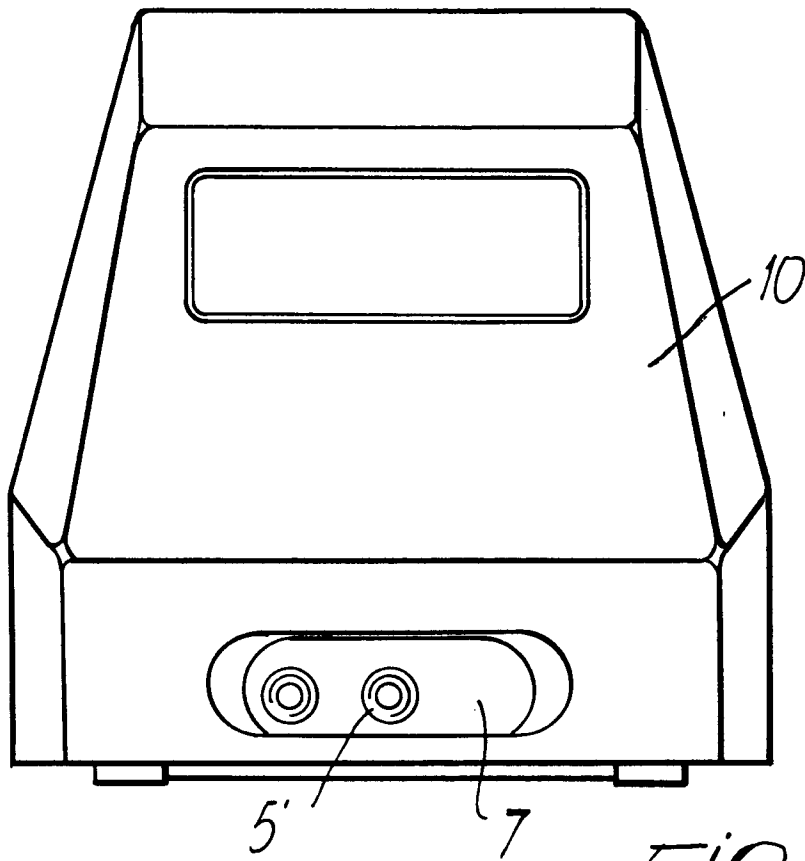

FIG. 4