

(19) **DANMARK**

(10) **DK/EP 3706841 T3**



Patent- og  
Varemærkestyrelsen

(12) **Oversættelse af  
europæisk patentskrift**

- 
- (51) Int.Cl.: **A 61 M 5/32 (2006.01)**
- (45) Oversættelsen bekendtgjort den: **2023-12-11**
- (80) Dato for Den Europæiske Patentmyndigheds bekendtgørelse om meddelelse af patentet: **2023-11-22**
- (86) Europæisk ansøgning nr.: **18765446.2**
- (86) Europæisk indleveringsdag: **2018-09-10**
- (87) Den europæiske ansøgnings publiceringsdag: **2020-09-16**
- (86) International ansøgning nr.: **EP2018074238**
- (87) Internationalt publikationsnr.: **WO2019091626**
- (30) Prioritet: **2017-11-07 EP 17200475**
- (84) Designerede stater: **AL AT BE BG CH CY CZ DE DK EE ES FI FR GB GR HR HU IE IS IT LI LT LU LV MC MK MT NL NO PL PT RO RS SE SI SK SM TR**
- (73) Patenthaver: **SHL Medical AG, Gubelstrasse 22 , PO Box 7710, 6302 Zug, Schweiz**
- (72) Opfinder: **LEANDER, Pär, Serenadvägen 18, 131 40 Nacka, Sverige**  
**HOLMQVIST, Anders, Skärgårdsvägen 207, 139 34 Värmdö, Sverige**
- (74) Fuldmægtig i Danmark: **Novagraaf Brevets, Bâtiment O2, 2 rue Sarah Bernhardt CS90017, F-92665 Asnières-sur-Seine cedex, Frankrig**
- (54) Benævnelse: **KANYLESKJOLDSFJERNER OG MEDIKAMENTAFGIVELSESIKKEHED, DER OMFATTER KANYLESKJOLDSFJERNEREN**
- (56) Fremdragne publikationer:  
**EP-A1- 2 468 328**  
**EP-A1- 2 878 322**  
**EP-A1- 2 886 144**  
**EP-A1- 3 222 313**  
**WO-A1-2015/110532**



# DESCRIPTION

## TECHNICAL FIELD

**[0001]** The present disclosure relates to a needle shield remover and in particular to a needle shield remover having a radially flexible body.

## BACKGROUND

**[0002]** Today's medicament delivery devices may be complex and involve many different components. The more components comprised in device, the more complicated and costly it becomes. It is therefore necessary to minimize the number of components and to reduce the cost and complexity of each individual component.

**[0003]** The present disclosure relates one such component, namely to a needle shield remover. The needle shield remover is often assembled with a cap, or closure member, of a medicament delivery device and is engaged to a needle shield, which protects a needle by hermetically enclosing it. The shield may comprise a flexible rubber member in which the needle is embedded, i.e. a flexible needle shield (FNS). For some applications, the FNS is provided with a rigid outer shell, i.e. a rigid needle shield (RNS). To be able to remove the needle shield before use of the medicament delivery device, the needle shield remover is provided with gripping members that engage the needle shield. Since the needle shield remover is attached to the cap, removal of the cap will also pull away the needle shield from the needle, due to the gripping members' engagement with the needle shield.

**[0004]** A conventional needle shield remover is disclosed in EP2255842, wherein a cap (manually operable member) comprises a needle shield remover (tubular shaped member), which surrounds a RNS. Flexible gripping members are arranged in the needle shield remover to engage the RNS such that when a user pulls the cap off a medicament delivery device, the needle shield remover will grip the RNS and pull it off an injection needle, thereby making the device ready for delivery of a dose of medicament.

**[0005]** EP2878322 A1 describes an invention that refers to a needle cap remover for a needle cap of a drug delivery device. The needle cap remover comprises a body having a material which differs from the material of the needle cap or of a rigid needle shield encasing the needle cap in at least one parameter, wherein a body portion, which covers the needle cap or the rigid needle shield encasing the needle cap, is adapted to capture the needle cap or the rigid needle shield encasing the needle cap by a positive and/or non-positive connections before or during removing of the needle cap and is adapted to shrink when a pulling force is applied.

**[0006]** EP3222313 A1 discloses a needle shield remover for removing a needle shield

covering a needle on a syringe includes a body having a proximal portion and a distal portion. The distal portion is moveable between a contracted configuration and an expanded configuration in response to opposite movement of the proximal portion. The distal portion includes an internal opening for receiving and at least partially surrounding a needle shield therein. An anchor extends inwardly from the distal portion into engagement with the needle shield when the distal portion is in the contracted configuration to secure the body to the needle shield. A sleeve is in fixed axial arrangement with the proximal portion of the body. The axial engagement maintains the distal portion of the body in the contracted configuration such that force applied to the sleeve away from the body removes the needle shield and body from a syringe.

**[0007]** WO2015110532 discloses a cassette unit suitable for use with an auto-injector having a drive unit. The cassette unit comprises a cassette unit housing defining a cassette unit housing cavity arranged for receipt of a syringe; a needle projection aperture; a needle cover defining a needle sheath for sheathing of a needle tip of the syringe; a removable cap that in a capping position fits over and thereby, acts such as to close off, the needle projection aperture, the removable cap defining a cap interior; provided to the removable cap, a cap insert; and provided to the cap insert, a connector defining one or more needle cover gripping elements for gripping the needle cover and the connector defines a central hub and the one or more needle gripper elements attach to the central hub and in spaced arrangement relative to each other. The connector locates within the removable cap such that the central hub of the connector is in spaced relationship with a forward end wall or surface of the cap interior and the needle cover gripping elements project away from the forward end cap wall or surface of the cap interior and towards the open end of the cap, and wherein the cap insert is shaped to allow for limited axial travel of the connector there within.

**[0008]** EP2886144 A1 discloses a drug delivery device comprising a housing capable of receiving and containing a container (syringe) and a needle safety device. The needle safety device comprises a needle cap arranged to cover and protect a needle, a needle shield relatively movable with respect to the housing to cover and protect the needle and a needle cap remover. The needle cap remover has an outer part adapted to be arranged to the housing and to cover the needle shield and partly the housing and an inner part adapted to be arranged to the needle cap.

**[0009]** EP2468328 A1 discloses an auto-injector for administering a dose of a liquid medicament (M), comprising- an outer casing, a syringe with a hollow needle and a stopper- a torsion spring and a gear arrangement for inserting the needle, delivering the medicament (M), and retracting the syringe after injection.

**[0010]** At least one skin contact trigger element is arranged at a proximal (P) end of the outer case, the skin contact trigger element translatable in longitudinal direction between a proximal position and a distal position and biased in proximal direction (P) in a manner to protrude from the outer casing in the proximal position, wherein in its proximal position the skin contact trigger element is arranged to prevent the spring means from being released and wherein the

skin contact trigger element in its distal position is arranged to allow release of the spring means.

**[0011]** However, the needle shield remover of the referenced prior art device suffers from the fact that it is costly, because it is formed out of a seamless stainless steel tube. In addition, the prior art device relies on relatively weak resilient force of flexible gripping members to engage the RNS and dislodge it from the injection needle - an operation which may require considerable force. The prior art gripping members may also rely on good tolerances for the gripping members to engage certain areas of the RNS, such as depressions in the outer circumferential surface, or the rear edge of the RNS. Since the position of the RNS relative to the needle shield remover may vary depending on tolerances of the glass container. The position may also depend on the handling of the delivery device since the container and its needle shield may move inside the delivery device, for instance due to accidental impacts. If the position of the needle shield is not correct, the prior art gripping members may not be able to engage the needle shield, which will result in the needle shield still being attached to the needle and to the container when the cap is removed from the housing.

## **SUMMARY**

**[0012]** In the present disclosure, when the term "distal" is used, this refers to the direction pointing away from the dose delivery site. When the term "distal part/end" is used, this refers to the part/end of the delivery device, or the parts/ends of the members thereof, which under use of the medicament delivery device is/are located furthest away from the dose delivery site. Correspondingly, when the term "proximal" is used, this refers to the direction pointing to the dose delivery site. When the term "proximal part/end" is used, this refers to the part/end of the delivery device, or the parts/ends of the members thereof, which under use of the medicament delivery device is/are located closest to the dose delivery site.

**[0013]** Further, the term "longitudinal", with or without "axis", refers to a direction or an axis through the device or components thereof in the direction of the longest extension of the device or the component.

**[0014]** The term "lateral", with or without "axis", refers to a direction or an axis through the device or components thereof in the direction of the broadest extension of the device or the component. "Lateral" may also refer to a position to the side of a "longitudinally" elongated body.

**[0015]** In a similar manner, the terms "radial" or "transversal", with or without "axis", refers to a direction or an axis through the device or components thereof in a direction generally perpendicular to the longitudinal direction, e.g. "radially outward" would refer to a direction pointing away from the longitudinal axis.

**[0016]** In view of the background outlined above, a general object of the present disclosure is

to provide a needle shield remover for a medicament delivery device, which needle shield remover is radially flexible and may exert a radial clamping force on a needle shield accommodated therein.

**[0017]** According to a main aspect of the disclosure it is characterised by a needle shield remover for a medicament delivery device, which needle shield remover comprises a metal tubular body, having a proximal part, a distal part, and a substantially circular cross-section, the tubular body is arranged with one slot in the tubular wall extending from a distal end of the body, at least half the length of the body, towards a proximal end, and in that an inner diameter of at least the distal part of the body, in a relaxed state, is smaller than an outer diameter of a needle shield that is to be accommodated by the body, such that at least the distal part of the body may flex radially outwards when the needle shield is inserted in the body to thereby exert a radially inwardly directed clamping force on the a needle shield accommodated by the body, wherein the radially inwardly directed clamping force of the body is configured to urge the rigid gripping members into contact with the needle shield accommodated by the body, wherein the body is formed of a rolled metal sheet, wherein the slot is formed of a gap between substantially parallel opposing edges of the rolled metal sheet, and wherein the rigid gripping members protrude radially inwards from the distal part of the body.

**[0018]** Due to the inner diameter of the body being smaller than the outer diameter of the needle shield, the body, or at least the distal part of the body, needs to flex radially outwards, i.e. to expand, to make room for the needle shield. When the needle shield is in place, i.e. accommodated in the body, the body will seek to return to the relaxed state and thereby exert a radially inwardly directed clamping force on the needle shield.

**[0019]** A rolled metal sheet is preferable to a tube in that it is easier and less expensive to manufacture the needle shield remover from a sheet than from a tube. It will also naturally provide the inwardly directed clamping force when it is flexed radially outwards.

**[0020]** An advantage of the rolled metal sheet is that the slot is formed by the space between the substantially parallel opposing edges of the metal sheet which is rolled to form the tubular body of the needle shield remover. The radial clamping force that is used to engage the needle shield is configured by adapting the diameter of the rolled body in relation to the diameter of the needle shield that is to be removed. A smaller diameter of the body results in a greater clamping force on the needle shield.

**[0021]** According to another object of the present disclosure the opposing edges of the proximal part of the body are arranged with mutually engaging structures such as to prevent radial flexing of the proximal part of the body when the distal part of the body flexes radially due to accommodation of a needle shield therein.

**[0022]** In order to stabilise the proximal part of the body at the connection with the cap, the metal sheet may be provided with an engaging structure, such as a positive connection, e.g. a jigsaw shape, at the proximal part of the body. The opposing edges of the proximal part of the

body may thereby be attached to each other to provide the proximal part of the tubular body with a rigid diameter.

**[0023]** According to another object of the present disclosure a transversal cut-out intersects the slot between the proximal part and the distal part to reduce radial flexing of the proximal part of the body when the distal part of the body flexes radially due to accommodation of a needle shield therein.

**[0024]** An alternative, or additional, solution is thereby provided to stabilise the proximal part of the tubular body by mechanically isolating the proximal part from the radial flexing of the distal part. The transversal slot intersects the longitudinal slot such that the radial forces resulting from the expansion of the distal part, as the needle shield remover accommodates the needle shield, are isolated and reduce the radial expansion forces on the proximal part.

**[0025]** According to another object of the present disclosure the rigid gripping members are formed as radially inwardly directed punched structures, having proximally directed edges to enhance friction between the body and a needle shield accommodated in the body, when the body is proximally urged.

**[0026]** The inwardly directed structures, having proximally directed edges, comprise holes punched out of the metal body, and the rim, or edge, of each hole is a relatively sharp lip that provides a frictional engagement with the outer surface of the needle shield accommodated in the body. Accordingly, an increased clamping force of the body of the needle shield remover also increases said frictional engagement since the gripping members are rigid and do not deform under the clamping force of the body.

**[0027]** According to another object of the present disclosure the proximal part of the tubular body is arranged with an attachment structure for connecting the needle shield remover to a cap of a medicament delivery device.

**[0028]** The tubular body forms the needle shield remover, which may be attached to a cap of a medicament delivery device, such that removal of the cap results in the removal of a needle shield that covers an injection needle of the medicament delivery device.

**[0029]** According to another object of the present disclosure the attachment structure comprises a circumferential groove formed in the tubular body.

**[0030]** A circumferential groove may be snap-fitted with a corresponding attachment structure of the cap.

**[0031]** According to another object of the present disclosure the attachment structure comprises radially outwardly directed tongues formed by cut-outs of the proximal end of the tubular body.

**[0032]** Tongues may be cut in the proximal end of the tubular body. The tongues are especially simple to cut and to bend in the metal sheet, which is thereafter rolled to form the tubular body.

**[0033]** According to another object of the present disclosure the attachment structure comprises a radially outwardly directed flange.

**[0034]** The proximal end of the body may also be formed as a radially outwardly directed flange, i.e. forming the attachment structure without tongues.

**[0035]** According to further object of the present disclosure a medicament delivery device comprises a needle shield remover according to any of the previous embodiments.

**[0036]** According to another object of the present disclosure a method of assembly of a needle shield remover with a cap according to any of the previous embodiments which comprises a generally tubular cap housing and a lid member, the method comprising steps of attaching the lid member to a proximal part of the cap housing (42); and configuring an attachment structure of the needle shield remover to be fixed or sandwiched between the lid member and the cap housing, such that the needle shield remover becomes axially fixed in relation to the cap, while a rotation of the needle shield remover relative to the cap is still allowed.

**[0037]** According to another object of the present disclosure a method of manufacturing a needle shield remover having a rolled metal sheet body for a medicament delivery device; the method of manufacturing the needle shield remover according to claims comprising steps of: supplying metal sheets and cutting into preferred widths and lengths; punching gripping members and attachment structures in the metal sheets; folding the attachment structures; forming the sheets into half-pipes; shaping of the half-pipes into tubular forms, which concluded the fabrication of the needle shield remover.

## **BRIEF DESCRIPTION OF THE DRAWINGS**

### **[0038]**

Fig. 1

a cross-sectional view of a prior art cap, needle shield remover, and syringe.

Fig. 2

a perspective view of a needle shield remover according to a first embodiment of the present disclosure.

Fig. 3

a perspective view of a needle shield remover according to a second embodiment of the present disclosure.

Fig. 4

an exploded perspective view of a cap and a needle shield remover according to a third

embodiment of the present disclosure.

Fig. 5

a cross-sectional view of a cap and a needle shield remover according to a third embodiment of the present disclosure.

## DETAILED DESCRIPTION

**[0039]** Fig. 1 shows a cross-sectional view of a known cap and needle shield remover. A needle 95 is fixedly mounted in a proximal end of a container 94, such as a glass syringe. The syringe is accommodated in a housing 99 of a medicament delivery device. A generally tubular cap 90 is assembled with a tubular needle shield remover 91 via a connection, where a mutual circumferential groove-protrusion 97 of the needle shield remover, mating with a corresponding protrusion-groove 98 of the cap 90. The cap-needle shield remover assembly is removably attached to the housing 99. A flexible needle shield 93b, embedding the needle 95, is attached to, and accommodated in, a rigid needle shield 93a. The needle shield remover 91 comprises flexible gripping members 92, in the form of radially inwardly protruding tongues, which engage the needle shield 93a and 93b by protruding into holes, or depressions, in a tubular wall of the rigid needle shield 93a. When the medicament delivery device is to be used, a user pulls the cap 90 proximally away from the housing 99. The gripping members 92 will thereby pull the rigid needle shield 93a and the flexible needle shield 93b off the needle 95, exposing the needle 95.

**[0040]** As previously described, prior art needle shield removers are relatively expensive components of a medicament delivery device, because they are often manufactured from seamless stainless steel tubes, which are cut in desired lengths and provided with gripping members 92 and attachment structures, such as the groove-protrusions 97, 98. They also rely on the flexible gripping members 92 being able to engage the needle shield, either at a depression at the circumferential side surface of the needle shield, or at the distal end, i.e. a rear-facing end surface of the needle shield. Due to tolerances and an uncertain position of the container 94 in relation to the housing 99, such an engagement cannot always be assured.

**[0041]** An object of the present disclosure is therefore to provide a less costly and more reliable needle shield remover. Basically, the solution pertains to a needle shield remover 30 which comprises a metal tubular body 100, 200, having a proximal part A, a distal part B, and a substantially circular cross-section, the tubular body 100, 200 being arranged with a slot extending from a distal end of the body, at least half the length of the body 100, 200, towards a proximal end, such that at least the distal part B of the body may flex radially outwards to exert a radially inwardly directed clamping force on a needle shield accommodated by the body 100, 200. See Figs 2-6.

**[0042]** The clamping force may be produced by ensuring that an inner diameter of at least the

distal part B of the body, in a relaxed state, is smaller than an outer diameter of the needle shield that is to be accommodated by the body. Thus, when the container with its needle and needle shield are mounted in a housing of the medicament delivery device, similarly to the prior art device shown in Fig. 1, the needle shield remover 30, which is assembled with a cap 40 (Fig. 7a and 7b), may be pushed onto the needle shield such that the distal part B of the body 100, 200 is radially expanded. As the metal body seeks to relax towards the relaxed, non-expanded state, the radially inwardly directed clamping force is exerted on the needle shield.

**[0043]** The clamping force may be exploited for the employment of an improved kind of rigid gripping members 32, as compared to the flexible prior art gripping members 92. The rigid gripping members 32 protrude radially inwards from a tubular wall of the distal part B of the body 100, 200. The gripping members 32 are formed as radially inwardly directed punched structures, having proximally directed edges to enhance friction between the body 100, 200 and a needle shield accommodated in the body 100, 200, when the body is proximally urged, such as when the cap 40 is removed from the housing of the medicament delivery device by the user.

**[0044]** The rigid gripping members 32 are relatively strong and mechanically resistant in relation to the conventional, flexible, gripping members 92. The radially inwardly directed clamping force of the body urges the rigid gripping members 32 into contact with a needle shield accommodated in the body 100, 200. By comparison, the conventional, flexible, gripping members 92 would be pressed flat against the needle shield due to the radial clamping force of the body 100, 200 of the needle shield remover 30. Consequently, flexible gripping members 92 would not be able to engage an outer surface of the needle shield.

**[0045]** The inwardly directed structures, having proximally directed edges, comprise holes punched out of the metal body. The rim, or edge, of each hole has a relatively sharp lip which provides a frictional engagement with the outer surface of the needle shield accommodated in the body 100, 200. Accordingly, an increased clamping force of the body of the needle shield remover also increases the frictional engagement since the gripping members 32 are rigid and do not deform under the clamping force of the body 100, 200.

**[0046]** The slot 10, 20 expands, or widens, as the needle shield is accommodated in the needle shield remover 30 from the distal end of the needle shield remover 30. Usually, the needle shield does not extend the whole length of the needle shield remover 30. The main flexing movement and clamping force of the needle shield remover will therefore be exerted by the distal part B. Furthermore, the proximal part is configured to be attached to the cap 40, as will be explained below. To ensure a good attachment to the cap it may be preferable to stabilise the proximal part A, to reduce the radial flexing thereof.

**[0047]** In one embodiment, the body 100 is formed of a rolled metal sheet. See Figs 2-5. The rolled metal sheet may be formed into a tubular body in a number of simple processing steps (Fig. 8). The metal sheet tubular body 100 is therefore a less costly alternative to the seamless stainless tube 91 of prior art devices. The diameter of the body 100 is furthermore easy to set

during manufacture of the body 100 to configure the appropriate clamping force.

**[0048]** The slot 10 of the rolled metal sheet tubular body is formed of a gap between substantially parallel opposing edges of the rolled metal sheet. The slot 10 extends the whole length of the body 100. Basically, the whole body may be allowed to flex radially as the needle shield is accommodated therein, without significantly affecting the attachment of the cap 40 at the proximal part A of the body 100. Such a configuration is shown in Fig. 2.

**[0049]** However, if the radial flexing of the proximal part A of the body 100 is perceived as a problem, various measures may be taken to reduce the flexing in the proximal part A, as mentioned above. Fig. 3 shows the needle shield remover 30 wherein a transversal cut-out 34 intersects the slot 10 between the proximal part A and the distal part B to reduce radial flexing of the proximal part A of the body when the distal part B of the body 100 flexes radially due to accommodation of a needle shield therein. The transversal cut-out thereby relieves the proximal part A of the radial forces at work in the distal part B when accommodating the needle shield in the needle shield remover 30, which stabilises the attachment of the needle shield remover with the cap 40. The transversal cut-out may be described as two transversal cut-out arms which extend from the slot 10. Each cut-out arm preferably extends at least a quarter of the circumference of the body 100 from the slot 10.

**[0050]** An alternative solution is shown in Figs 4 and 5, wherein the opposing edges of the proximal part A of the body 100 are arranged with mutually engaging structures 36a, 36b such as to prevent radial flexing of the proximal part of the body when the distal part of the body flexes radially due to accommodation of a needle shield therein. The mutually engaging structure 36a (Fig. 4) is shown as a positive connection, such as a jigsaw connection 36a. Other forms of connections are also conceivable, such as latches, snap fits, etc. The purpose is to lock the opposing edges of the proximal part A to each other to reduce the radial flexing.

**[0051]** Another alternative solution to achieve the stable proximal part A, but still provide the clamping forces around the needle shield is to form the slot 20 as a partial cut-out from a distal end of a wall of a metal tube such that the proximal part A of the body 200 is radially rigid and the distal part B of the body 200 is radially flexible. See Fig. 6. Obviously, the advantage of the low-cost, rolled metal sheet is lost, but the clamping forces achieved by the slot still allow the use of the rigid gripping members 32.

**[0052]** In Figs 2-7, the needle shield remover 30 is shown with the body 100, 200 arranged with an attachment structure 38, 39 for connecting the needle shield remover to a cap 40 of a medicament delivery device. The attachment structure may be radially extending tongues 38 formed by cut-outs of the proximal end of the tubular body 100, 200 or a radially outwardly directed flange 39 (Fig. 6).

**[0053]** Fig. 7a and 7b show an assembly of the needle shield remover 30 with a cap 40. The cap comprises a generally tubular cap housing 42 and a lid member 44. The lid member 44 may be attached to a proximal part of the cap housing 42 by conventional means such as

latches, catches, snap-fits, etc. The attachment structure 38, 39 of the needle shield remover 30 may be configured to be fixed, or sandwiched, between the lid member 44 and the cap housing 42, such that the needle shield remover 30 becomes axially fixed in relation to the cap 40. Rotation of the needle shield remover 30 relative to the cap 40 may still be allowed in order to reduce the problem of coring of the needle if the cap is rotated relative to the medicament delivery device upon removal of the cap 40 from the device.

**[0054]** An alternative attachment structure may be the conventional groove-protrusion structure known from prior art. An elongated protrusion along the circumferential surface of the body 100, 200 is configured to mate with an elongated groove of a corresponding attachment structure of the cap 40 in a snap-fit connection (not shown). Of course, the protrusion of the body may be exchanged for a groove, and the groove of the cap may be exchanged for a corresponding protrusion. However, the radially extending tongues 38, or flange 39, described above, are more robust to any radial flexing of the proximal part A of the needle shield remover 30.

**[0055]** Fig. 8 shows a conceptual view of some manufacturing steps of the needle shield remover 30 having a rolled metal sheet body 100. Metal sheets are supplied (i) and cut into preferred widths and lengths. Gripping members and attachment structures are punched in the metal sheets (ii). The attachment structures are folded (iii). The sheets are formed into half-pipes (iv), followed by shaping of the half-pipes into tubular forms (v), which concludes the fabrication of the needle shield remover (vi).

## REFERENCES CITED IN THE DESCRIPTION

### Cited references

This list of references cited by the applicant is for the reader's convenience only. It does not form part of the European patent document. Even though great care has been taken in compiling the references, errors or omissions cannot be excluded and the EPO disclaims all liability in this regard.

### Patent documents cited in the description

- [EP2255842A \[0004\]](#)
- [EP2878322A1 \[0005\]](#)
- [EP3222313A1 \[0006\]](#)
- [WO2015110532A \[0007\]](#)

- EP2886144A1 [0008]
- EP2468328A1 [0009]

## PATENTKRAV

1. Kanyleskjoldsfjerner (30) til en medikamentafgivelsesindretning, hvilken kanyleskjoldsfjerner (30) omfatter en rørformet metalkrop (100) med en proksimal del (A), en distal del (B) og et i det væsentlige cirkulært tværsnit, hvor den  
5 rørformede krop (100) er anbragt med én slids (10), i den rørformede væg, som strækker sig fra en distal ende af kroppen (100), mindst over halvdelen af kroppens (100) længde, hen imod en proksimal ende, og ved at en indvendig diameter af mindst den distale del (B) af kroppen (100), i en afspændt tilstand, er mindre end en udvendig diameter af et kanyleskjold, som skal indeholdes i kroppen (100), således  
10 at mindst den distale del af kroppen (100) kan bøje sig radialt udad, når kanyleskjoldet indføres i kroppen, for derved at udøve en radialt indadtil rettet fastspændingskraft på kanyleskjoldet, der er indeholdt i kroppen (100), hvor kroppens radialt indadtil rettede fastspændingskraft er konfigureret til at presse de stive gribeelementer (32) ind i kontakt med kanyleskjoldet, der er indeholdt i  
15 kroppen (100), hvor kroppen (100) er dannet af en udvalset metalplade, hvor slidsen (10) er dannet af en spalte mellem i det væsentlige parallelle modstående kanter på den udvalsedede metalplade, og hvor de stive gribeelementer (32) rager radialt indad fra den distale del af kroppen (100).
2. Kanyleskjoldsfjerner ifølge krav 1, hvor de modstående kanter på den  
20 proksimale del (A) af kroppen (100) er anbragt med indbyrdes indgribende strukturer (36a, 36b) med henblik på at forhindre radial bøjning af den proksimale del (A) af kroppen (100), når den distale del (B) af kroppen (100) bøjer sig radialt på grund af, at der deri er indeholdt et kanyleskjold.
3. Kanyleskjoldsfjerner (30) ifølge krav 1, hvor et tværsnit (34)  
25 gennemskærer slidsen (10) mellem den proksimale del (A) og den distale del (B) med henblik på at reducere radial bøjning af den proksimale del (A) af kroppen (100), når den distale del (B) af kroppen (100) bøjer sig radialt på grund af, at der deri er indeholdt et kanyleskjold.
4. Kanyleskjoldsfjerner (30) ifølge krav 1, hvor de stive gribeelementer (32)  
30 er dannet som radialt indadtil rettede udstansede strukturer med proksimalt rettede kanter med henblik på at forbedre friktion mellem kroppen (100) og et

kanyleskjold, der er indeholdt i kroppen (100), når kroppen (100) presses proksimalt.

5. Kanyleskjoldsfjerner (30) ifølge krav 1, hvor den proksimale del (A) af den rørformede krop (100) er indrettet med en fastgørelsesstruktur (38, 39) med henblik på at forbinde kanyleskjoldsfjerner (30) med en hætte (40) på en medikamentafgivelsesindretning.
6. Kanyleskjoldsfjerner (30) ifølge krav 5, hvor fastgørelsesstrukturen omfatter en periferisk rille, der er dannet i den rørformede krop.
7. Kanyleskjoldsfjerner (30) ifølge krav 5, hvor fastgørelsesstrukturen (38) omfatter radiale udadtil rettede tunger, der er dannet af udskæringer i den proksimale ende af den rørformede krop (100).
8. Kanyleskjoldsfjerner (30) ifølge krav 5, hvor fastgørelsesstrukturen (39) omfatter en radiale udadtil rettet flange.
9. Medikamentafgivelsesindretning, der omfatter en kanyleskjoldsfjerner (30) ifølge et hvilket som helst af de foregående krav.
10. Fremgangsmåde til samling af en kanyleskjoldsfjerner (30) ifølge krav 1-8 med en hætte (40), der omfatter et generelt rørformet hættehus (42) og et lågelement (44), hvilken fremgangsmåde omfatter følgende trin:
  - fastgørelse af lågelementet (44) til en proksimal del af hættehuset (42); og
  - konfigurerings af en fastgørelsesstruktur (38, 39) af kanyleskjoldsfjerner (30) med henblik på at være fikseret eller indeklemmet mellem lågelementet (44) og hættehuset (42), således at kanyleskjoldsfjerner (30) bliver aksialt fikseret i forhold til hætten (40), mens en rotation af kanyleskjoldsfjerner (30) i forhold til hætten (40) stadig muliggøres.
11. Fremgangsmåde til fremstilling af en kanyleskjoldsfjerner (30) med en udvalset metalpladekrop (100) til en medikamentafgivelsesindretning; hvor fremgangsmåden til fremstilling af kanyleskjoldsfjerner (30) ifølge krav 1-10 omfatter følgende trin:

- tilførsel af metalplader og udskæring i foretrukne bredder og længder;
- udstansning af gribeelementer (32) og fastgørelsesstrukturer (38) i metalpladerne;
- foldning af fastgørelsesstrukturerne (38);
- 5 - dannelse af pladerne til halve rør;
- formning af de halve rør til rørformer (100), hvilket afslutter fremstillingen af kanyleskjoldsfjerner (30).

# DRAWINGS

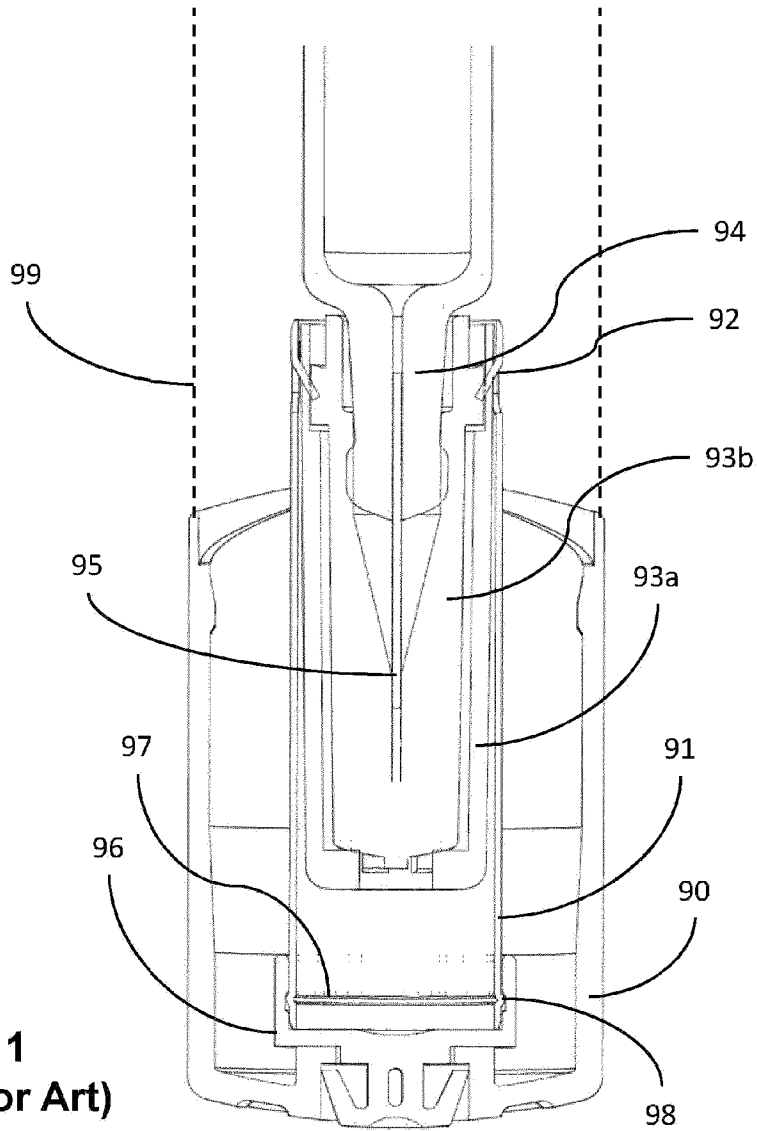

**Fig. 1**  
**(Prior Art)**

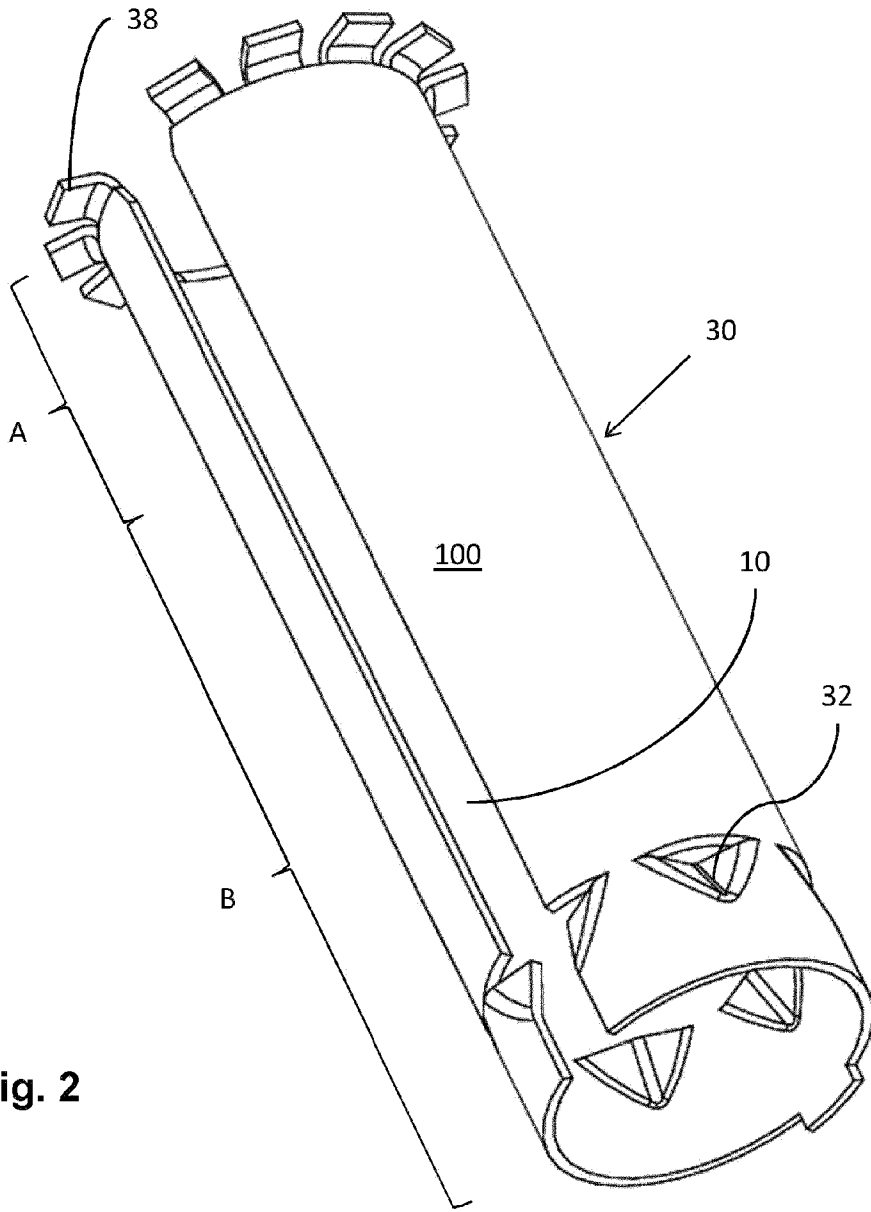

Fig. 2

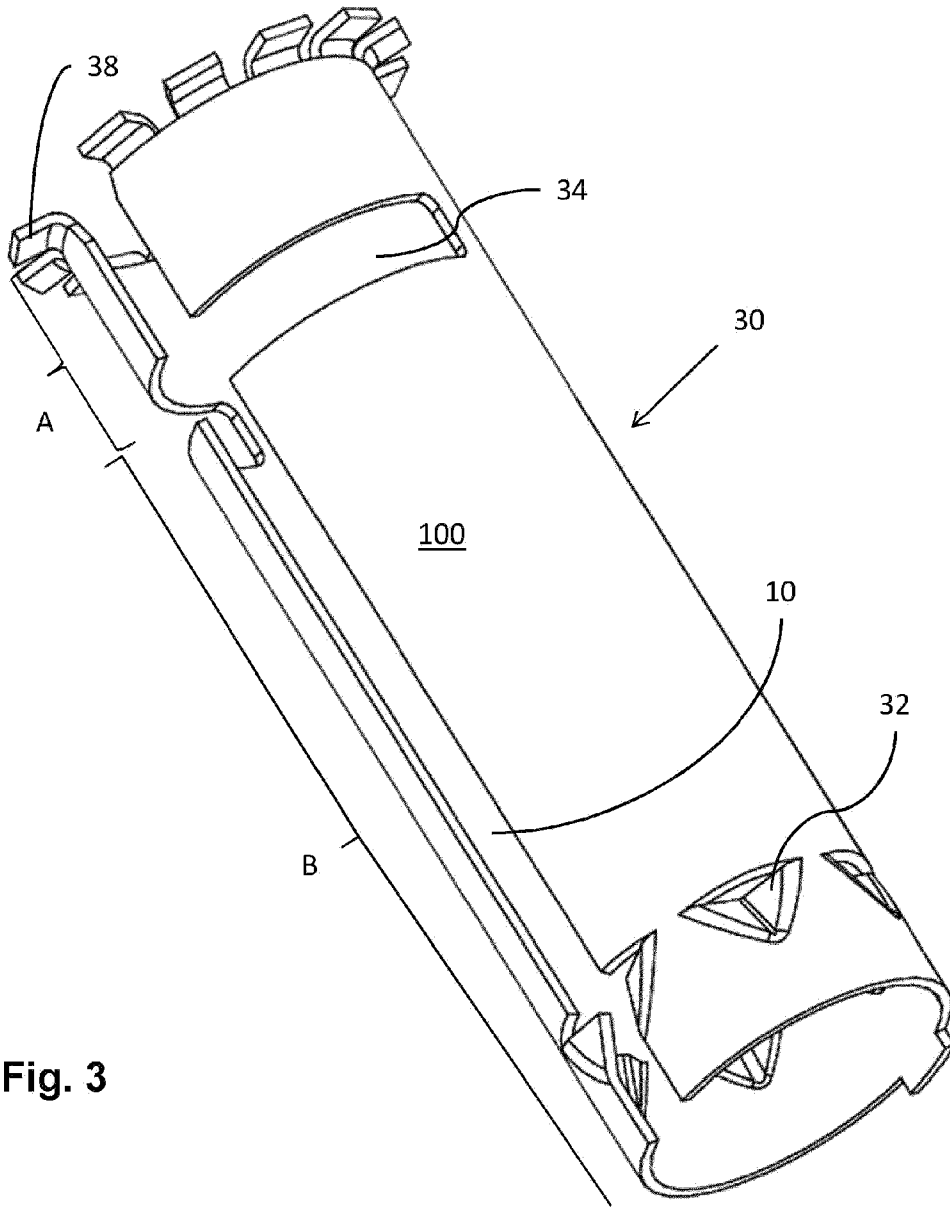

Fig. 3

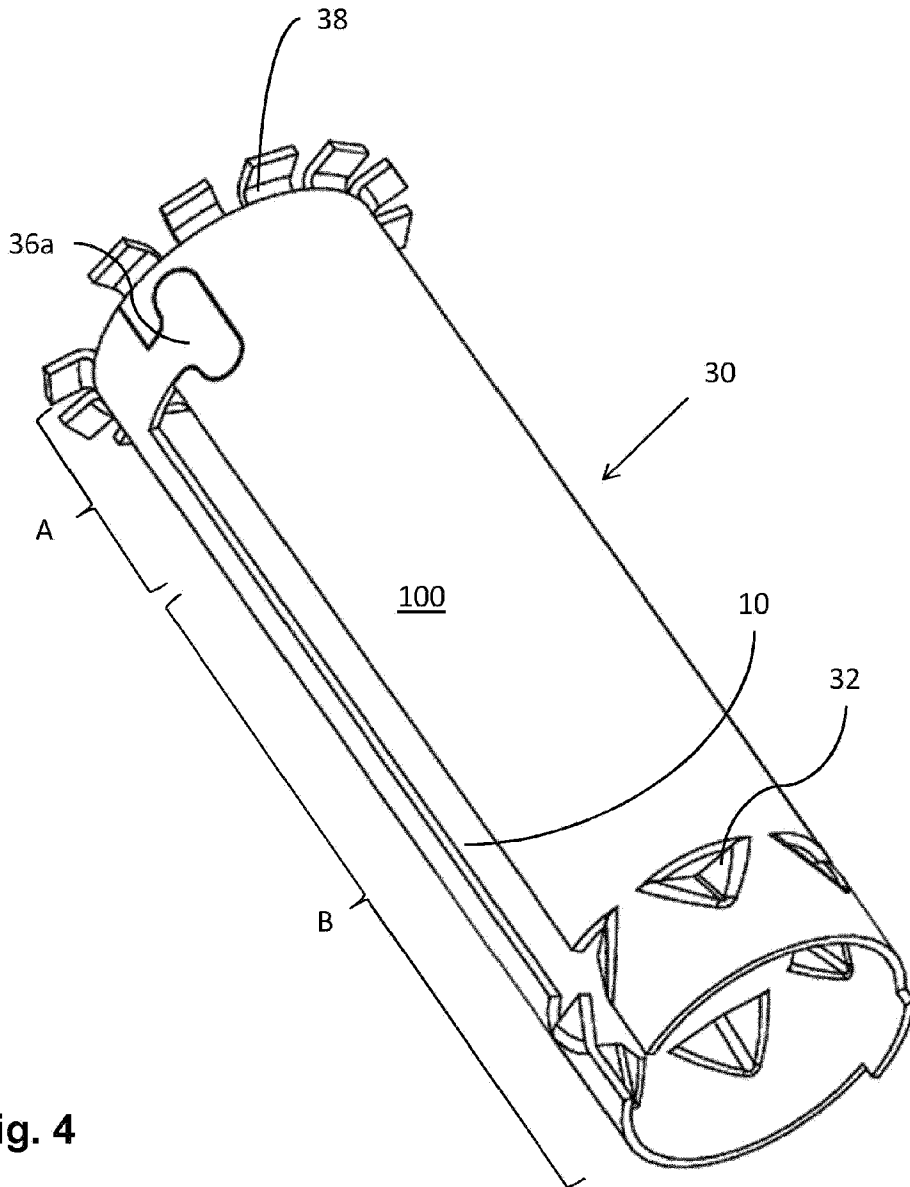

Fig. 4

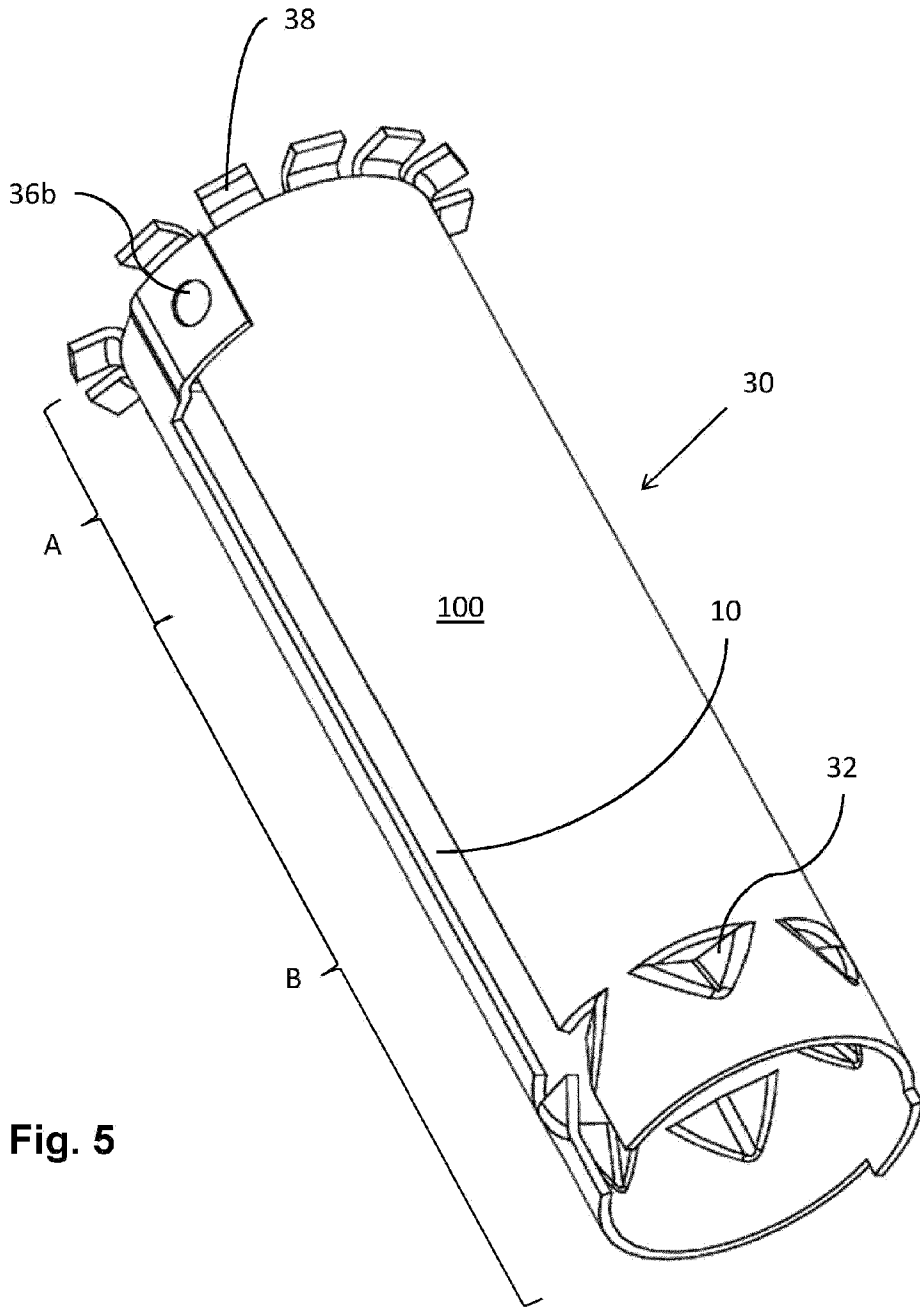

Fig. 5

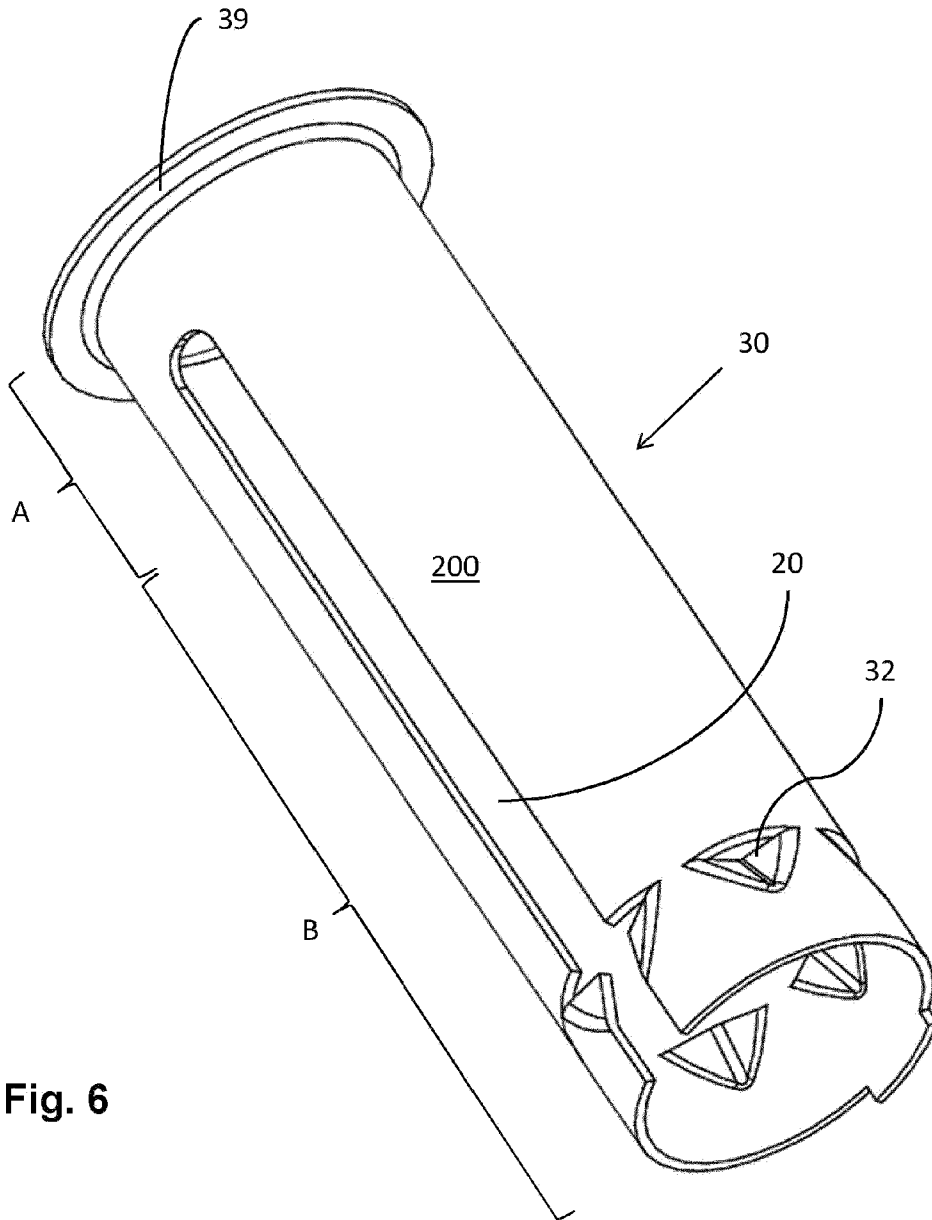

Fig. 6

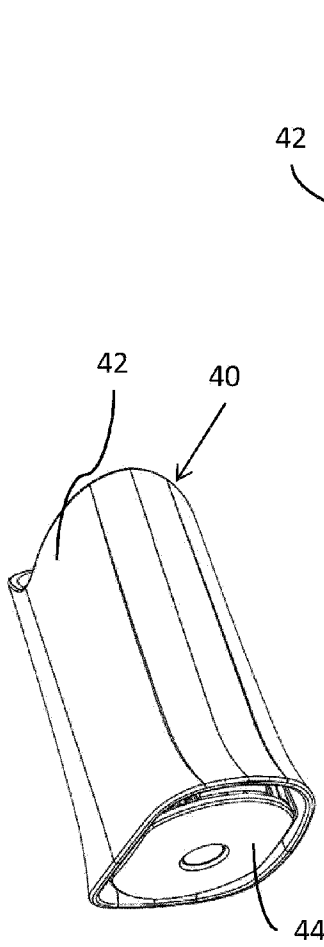

Fig. 7A

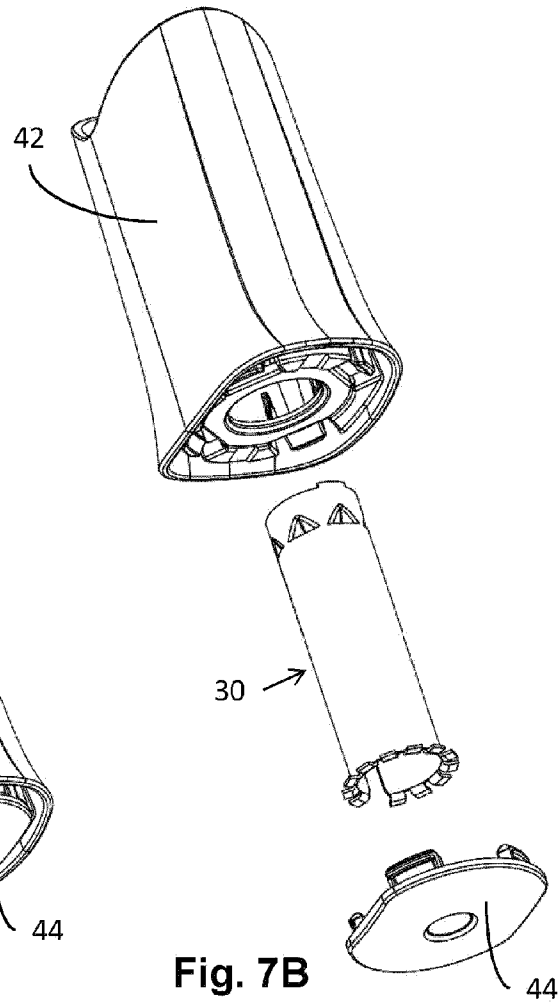

Fig. 7B

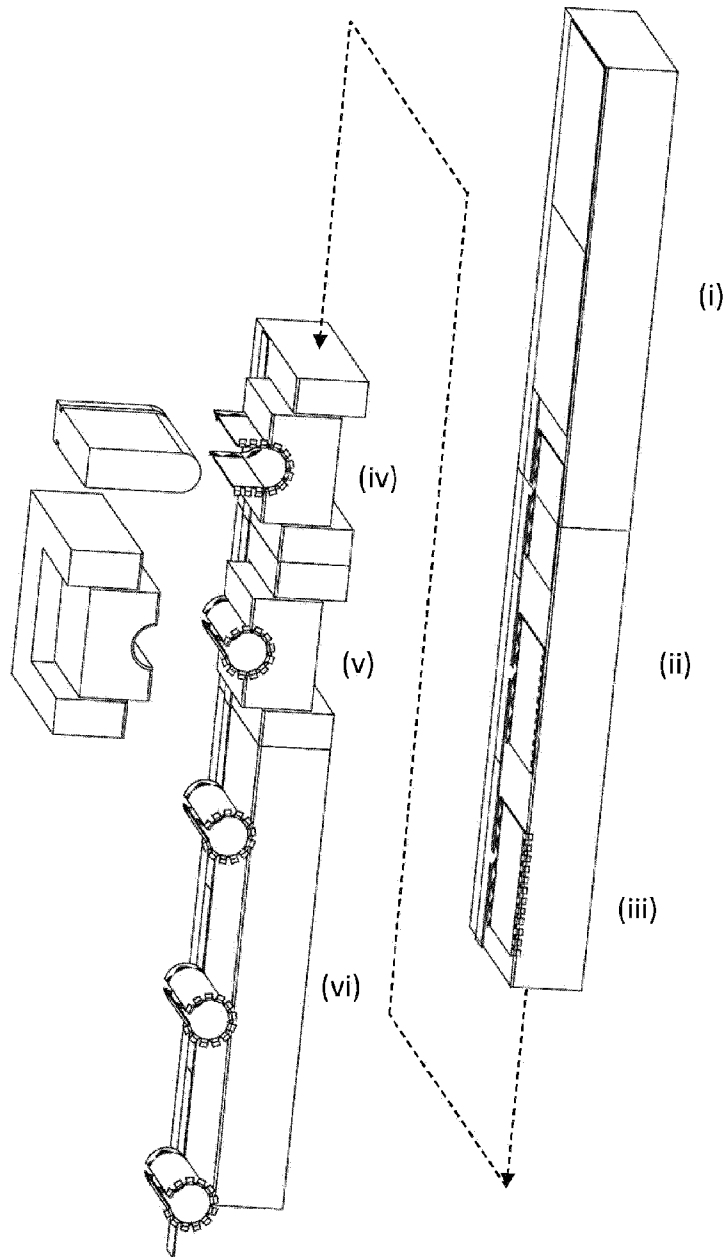

Fig. 8