

(19) World Intellectual Property Organization  
International Bureau



(43) International Publication Date  
19 April 2001 (19.04.2001)

PCT

(10) International Publication Number  
**WO 01/27386 A1**

(51) International Patent Classification<sup>7</sup>: D21F 1/06, 1/08

20, FIN-40520 Jyväskylä (FI). SAARENRINNE, Pentti [FI/FI]; Huikarinkatu 2, FIN-33820 Tampere (FI).

(21) International Application Number: PCT/FI00/00872

(74) Agent: KOLSTER OY AB; Iso Roobertinkatu 23, P.O. Box 148, FIN-00121 Helsinki (FI).

(22) International Filing Date: 11 October 2000 (11.10.2000)

(25) Filing Language: English

(81) Designated States (*national*): AE, AG, AL, AM, AT, AT (utility model), AU, AZ, BA, BB, BG, BR, BY, BZ, CA, CH, CN, CR, CU, CZ, CZ (utility model), DE, DE (utility model), DK, DK (utility model), DM, DZ, EE, EE (utility model), ES, FI, FI (utility model), GB, GD, GE, GH, GM, HR, HU, ID, IL, IN, IS, JP, KE, KG, KP, KR, KR (utility model), KZ, LC, LK, LR, LS, LT, LU, LV, MA, MD, MG, MK, MN, MW, MX, MZ, NO, NZ, PL, PT, RO, RU, SD, SE, SG, SI, SK, SK (utility model), SL, TJ, TM, TR, TT, TZ, UA, UG, US, UZ, VN, YU, ZA, ZW.

(26) Publication Language: English

(30) Priority Data:  
19992195 12 October 1999 (12.10.1999) FI

(71) Applicant (*for all designated States except US*): METSO PAPER INC. [FI/FI]; Fabianinkatu 9 A, FIN-00130 Helsinki (FI).

(72) Inventors; and

(84) Designated States (*regional*): ARIPO patent (GH, GM, KE, LS, MW, MZ, SD, SL, SZ, TZ, UG, ZW), Eurasian patent (AM, AZ, BY, KG, KZ, MD, RU, TJ, TM), European patent (AT, BE, CH, CY, DE, DK, ES, FI, FR, GB, GR, IE, IT, LU, MC, NL, PT, SE), OAPI patent (BF, BJ, CF, CG, CI, CM, GA, GN, GW, ML, MR, NE, SN, TD, TG).

(75) Inventors/Applicants (*for US only*): AHOLA, Jussi [FI/FI]; Melakatu 2 D 23, FIN-33410 Tampere (FI). POHJALA, Elina [FI/FI]; Tasanteenraitti 4 E 9, FIN-33610 Tampere (FI). SOINI, Sakari [FI/FI]; Kermisenkuja 5 C 16, FIN-31400 Somero (FI). RAJALA, Veli-Matti [FI/FI]; Leinolankatu 78, FIN-33580 Tampere (FI). LINDROOS, Kati [FI/FI]; Mekaniikanpolku 18 B 20, FIN-33720 Tampere (FI). NYBERG, Petri [FI/FI]; Ruulahdentie 16 B

Published:  
— With international search report.

[Continued on next page]

(54) Title: METHOD AND ARRANGEMENT FOR MIXING PULP COMPONENTS IN THE MANUFACTURE OF PAPER

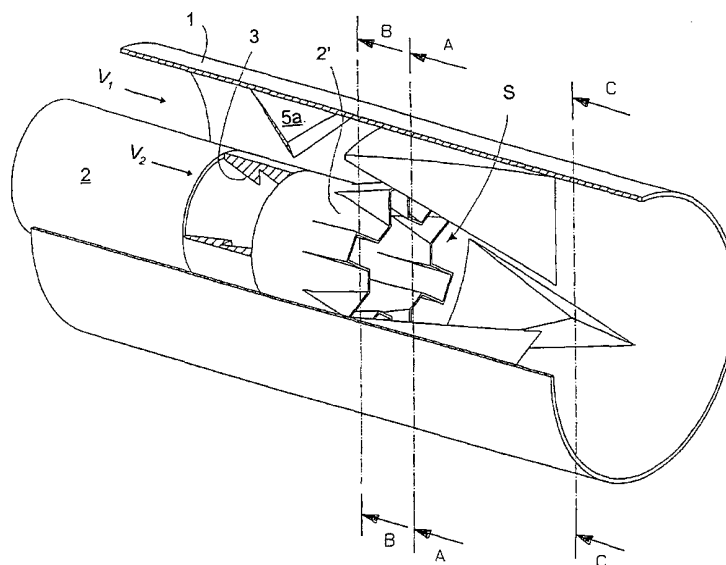

(57) Abstract: The invention relates to a method of mixing pulp components in the manufacture of paper, in which method the pulp components to be mixed are led to a mixing point (S) along tubes arranged inside each other. The pulp component flows are mixed by generating turbulence in them by means of the end of an inner tube (2; 2a to 2c), the cross-section of which end is wave-like. This turbulence is guided and its effect is intensified by means of form parts (4a to 4c) in connection with the mixing point, which form parts are arranged on the inner surface of the outer tube. Further, the invention relates to an arrangement implementing the mixing of pulp components in accordance with the method.

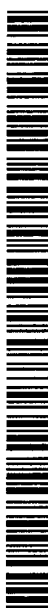

WO 01/27386 A1



---

*For two-letter codes and other abbreviations, refer to the "Guidance Notes on Codes and Abbreviations" appearing at the beginning of each regular issue of the PCT Gazette.*

## **METHOD AND ARRANGEMENT FOR MIXING PULP COMPONENTS IN THE MANUFACTURE OF PAPER**

The invention relates to a method of mixing pulp components in the manufacture of paper, according to which method a first pulp component is fed  
5 along an outer tube to a mixing point, the other pulp components being fed along at least one inner tube arranged inside the outer tube to the mixing point, whereby flows of said pulp components combine at the mixing point.

Further, the invention relates to an arrangement for mixing pulp components in the manufacture of paper, which arrangement comprises an  
10 outer tube for leading a first pulp component to a mixing point and at least one inner tube arranged inside the outer tube, whereby the inner tube is arranged substantially in parallel with the outer tube at least by its outer end, and in which arrangement a second pulp component is arranged to be led from the inner tube to the mixing point in such a way that flows of the pulp components  
15 to be fed are arranged to combine at the mixing point.

There are several points in different processes of paper manufacture where different mixtures of fluid and desired pulps and other substances have to be mixed with each other. For example, fibre pulp is thickened and diluted as required by feeding fibre suspension or dilution water thereto prior to  
20 leading it to the head box of the paper machine. Required additives, such as colouring, retention and filling agents, may also be mixed into the main flow. The fluids may be mixed using different tube mixers or by means of mechanical mixers in a tank. Cones and different tube joints, such as T and Y joints, are utilized for the mixing taking place in a tube. Further, additives may be  
25 mixed into a fluid flow by feeding them as jets against the main flow in the direction of the radius. A problem with known solutions is, however, that the mixing does not take place in a satisfactory way, which causes various problems at the following stages of the process. For example, variation in the consistency of the fibre flow as a result of inferior mixing in the dilution or thickening easily leads to problems in the product quality.  
30

An object of the present invention is to provide a novel and improved solution for mixing pulp components in a tube.

The method according to the invention is characterized by generating at the mixing point turbulence in the flows of the pulp components to be  
35 mixed by means of an inner tube end having a wave-like cross-section, and by guiding the turbulence generated in this way by means of form parts posi-

tioned in the vicinity of the inner tube end and arranged on the inner surface of the outer tube (1), the greatest cross-section of the form parts being after the outermost end of the inner tube in the direction of flow.

Further, the arrangement according to the invention is characterized  
5 in that the outer end of the inner tube has a wave-like cross-section, whereby it is arranged to generate turbulence in the flows to be mixed; that in connection with the mixing point, there are form parts arranged on the inner surface of the outer tube for guiding the generated turbulence; and that the greatest  
10 cross-section of the form parts is after the outermost end of the inner tube in the direction of flow.

The essential idea of the invention is that the pulp components are fed to the mixing point of the pulp components along tubes arranged inside each other. For the purpose of mixing, the cross-section of the inner tube end is made wave-like, whereby it generates turbulence in the pulp component  
15 flows. The mixing effect of the turbulence is intensified by means of form parts arranged on the inner surface of the outer tube in connection with the mixing point, which form parts guide and intensify the generated turbulence. Still further, the essential idea of a preferred embodiment of the invention is that the cross-section of a form part changes in the direction of the radius and periphery of the outer tube in the direction of flow, whereby it changes from a linear  
20 front edge to a sector of a circle and back to a linear rear edge.

An advantage of the invention is that the pulp components to be mixed can be mixed with each other more efficiently and reliably than before, whereby the earlier problems at the following stages of the manufacturing  
25 process, resulting from the mixing, can be avoided. This naturally improves the efficiency of the process and enables manufacture of products having uniform quality. Moreover, good mixing even allows smaller amounts of additional components to be mixed into the main flow, because now inferior mixing does not have to be compensated for with oversized feed of components. Form  
30 parts according to the invention allow intensification of the turbulence generated by means of the inner tube end having a wave-like cross-section, more efficient mixing of the pulp components being consequently achieved. Further, what is known as the ejector effect can be reduced by means of form parts. As a form part is formed in such a way that its cross-section area begins from  
35 zero and ends at zero, the fibres or other component parts do not adhere to it but it remains clean easily. Combining an inner tube having a suitable wave-

like form and suitable dimensions with form parts suitably dimensioned and appropriately positioned relative to the end of the inner tube allows the tailoring of a mixer giving the best possible result in each particular case.

5 The invention is described in more detail in the attached drawings, in which

Figure 1 is a schematic sectional perspective view of an arrangement according to the invention; and Figure 2 illustrates, also as a perspective view, a corresponding arrangement seen from a slightly different angle;

10 Figures 3a to 3c schematically illustrate cross-sections of the arrangement according to the preceding figures; and

Figure 4 is a schematic sectional view of still another application of the arrangement according to the invention.

Figure 1 illustrates a simplified view of an arrangement according to the invention. The arrangement comprises an outer tube 1, one side of which  
15 has been sectioned in the figure to show the structure of the tube. An inner tube 2 is arranged inside the outer tube, substantially in parallel with the outer tube. Preferably, the tubes 1 and 2 are arranged coaxially. A first flow  $V_1$  denoted in the figure flows in the outer tube, while a second flow  $V_2$  flows in the inner tube. The pulp component flowing in the tubes is a mixture of a fluid and  
20 a suitable dry solid, such as a mixture of fibre and water, or alternatively mere fluid, such as dilution water. Generally, the main flow which consists of fibre pulp, for example, is led along an annular channel limited by the outer tube and the inner tube. Correspondingly, a side flow to be mixed into the main flow is led along the channel limited by the inner tube, which side flow consists of  
25 dilution water or some additive, for example. It is obvious that the flows may also be arranged in the opposite way. The flows  $V_1$  and  $V_2$  are mixed with each other at a mixing point denoted by S in the figure. The mixing is brought about by generating turbulence in the flows. For this purpose, the cross-section form of the end 2' of the inner tube is wave-like. The wave-like form refers to, for  
30 example, a sine wave, a serrated wave, a rectangular wave or other wavelike forms applicable to the purpose, by means of which the flows can be made swirl. Further, the inner tube may comprise a fluidizator 3 before the wave-like end. This kind of a fluidizator further intensifies the mixing, particularly when the consistency of the flowing substance is high (a plug flow). The fluidizator  
35 shown in the figure first comprises a converging part in the direction of flow, which part then enlarges rapidly, causing changes in the flow rate and pres-

sure. The structure and operating principle of such a fluidizator as such are known to a person skilled in the art and are therefore not described in greater detail herein.

In accordance with the idea of the invention, form parts 4a to 4c are  
5 arranged in the outer tube in the part following the end of the inner tube, the purpose of which pieces is to affect the turbulence generated by means of the wave-like cross-section form of the inner tube end 2' and thus to further intensify the mixing of the pulp components. Such form parts are arranged on the inner periphery of the outer tube and their number and dimensioning are de-  
10 termined as required. Preferably, there are three form parts arranged at equal distances from each other on the periphery of the tube 1 and at equal distances from the inner tube in the direction of the longitudinal axis of the tubes. A preferred cross-section of the form parts can be seen in Figure 3a. Seen from the direction of flow, the area of a form part is at first zero, because its  
15 front edge is a linear surface in the direction of the periphery; when proceeding in the direction of flow, the area grows in the direction of the radius into a cross-section formed as a sector of a circle. At the same time as it grows in the direction of the radius of the tube 1, proceeding in the direction of flow, the form part begins to diminish in the direction of the periphery. Hence, the rear  
20 edge of the form part is linear again, as can be clearly seen in Figure 3b. Such form parts can also be arranged in such a way that the sharp edge in the direction of the radius is directed forwards, i.e. in the manner exactly opposite to what is shown in the figures. In both cases, it is typical of the form part that it begins as a linear surface, its area being substantially zero, and ends again  
25 as a linear surface. Such a form part easily remains clean, because fibres and other substances in the flow do not easily adhere to it. Further, such a form part directs the flows flexibly toward each other and affects in this way the mixing of the pulp components. Although the figures show that the front edge of the form part is at the end of the inner tube, it is totally feasible to arrange  
30 the form parts and the end of the inner tube end in such a manner that they overlap part of the way, but in such a manner that the greatest cross-section of the form parts is after the inner tube end in the direction of flow. Thus, the flows have time to mix sufficiently as a result of the turbulence before the form parts start to guide them. Correspondingly, the form parts may be arranged at  
35 a predetermined distance from the end of the inner tube in the direction of flow.

Figure 3c, in particular, shows second form parts 5a to 5c arranged on the inner surface of the outer tube 1 before the end of the inner tube in the direction of flow. Such form parts also generate turbulence and intensify the mixing. These form parts may be pyramid-like, as shown in the figure, or alternatively, profiles like the form parts after the mixing point may be used.

Mixing characteristics of the arrangement according to the invention may be adjusted by changing the position of the form parts relative to the wave-like end of the inner tube, by changing the dimensions and/or the form of the form parts and by combining a suitable number of different form parts. Further, the form parts may in some cases be arranged at slightly different distances from the inner tube end in the direction of the longitudinal axis of the outer tube and at irregular distances on the periphery. The form parts may also be adjustable. This allows, for example, adjustment of the position of the form parts both relative to the tube and relative to each other. As regards their form and dimensions, the form parts may also be constructed in such a way that they can be adjusted in different ways.

Figure 4 shows a solution having several, in this case three, inner tubes 2a to 2c in the direction of the outer tube. If required, there may be more inner tubes. The cross-section of each inner tube end is wave-like. Form parts growing in the direction of the radius and diminishing in the direction of the periphery are arranged in connection with the mixing point. Second form parts before the mixing point may also be used.

Further, form parts may in some cases be used for facilitating the support of inner tubes inside the outer tube.

The drawings and the related description are only intended to illustrate the idea of the invention. The details of the invention may vary within the scope of the claims.

## CLAIMS

1. A method of mixing pulp components in the manufacture of paper, according to which method a first pulp component is fed along an outer tube (1) to a mixing point (S), the other pulp components being fed along at least one inner tube (2; 2a to 2c) arranged inside the outer tube to the mixing point, whereby flows ( $V_1$  to  $V_4$ ) of said pulp components combine at the mixing point (S), **characterized** by generating at the mixing point (S) turbulence in the flows ( $V_1$  to  $V_4$ ) of the pulp components to be mixed by means of an inner tube end (2') having a wave-like cross-section; and by guiding the generated turbulence by means of separate form parts (4a to 4c) positioned in the vicinity of the inner tube end (2') and arranged on the inner surface of the outer tube (1), the greatest cross-section of the form parts being after the outermost end of the inner tube in the direction of flow.

2. A method according to claim 1, **characterized** by fluidizing at least one of the flows ( $V_1$  to  $V_4$ ) of the pulp components prior to leading it to the mixing point (S).

3. A method according to claim 1 or 2, **characterized** by arranging several inner tubes inside the outer tube, whereby several separate flows are led to the mixing point (S).

4. An arrangement for mixing pulp components in the manufacture of paper, which arrangement comprises an outer tube (1) for leading a first pulp component to a mixing point (S), and at least one inner tube (2; 2a to 2c) arranged inside the outer tube, whereby the inner tube is arranged substantially parallel with the outer tube at least by its outer end, a second pulp component being arranged to be led to the mixing point in such a way that flows ( $V_1$  to  $V_4$ ) of the pulp components to be fed are arranged to combine in the mixing point (S), **characterized** in that the outer end (2') of the inner tube has a wave-like cross-section, whereby it is arranged to generate turbulence in the flows ( $V_1$  to  $V_4$ ) to be mixed; that in connection with the mixing point (S), there are form parts (4a to 4c) arranged on the inner surface of the outer tube (1) for guiding the generated turbulence; and that the greatest cross-section of the form parts is after the outermost end of the inner tube in the direction of flow.

5. An arrangement according to claim 4, **characterized** in that the area of the form parts (4a to 4c) in the direction of flow is at first zero,

growing then in the direction of the radius or periphery of the outer tube until it diminishes again to zero in the direction of the radius or periphery, whereby the front and rear edges of the form part are linear and in the part between them the area of the form part has the form of a sector of a circle.

5           6. An arrangement according to claim 5, **characterized** in that the front edge of the form part (4a to 4c) is a linear surface in the direction of the periphery of the outer tube (1), and the rear edge of the form part is, in turn, a linear surface in the direction of the radius of the outer tube.

10           7. An arrangement according to claim 5, **characterized** in that the front edge of the form part (4a to 4c) is a linear surface in the direction of the radius of the outer tube (1), and the rear edge of the form part is, in turn, a linear surface in the direction of the periphery of the outer tube.

15           8. An arrangement according to any one of claims 4 to 7, **characterized** in that the arrangement comprises second form parts (5a to 5c) on the inner surface of the outer tube (1) before the mixing point (S).

            9. An arrangement according to any one of claims 4 to 8, **characterized** in that the inner tube (2; 2a to 2c) comprises a fluidizator (3) before the wave-like end (2').

20           10. An arrangement according to any one of claims 4 to 9, **characterized** in that the position of the form parts is adjustable.

            11. An arrangement according to any one of claims 4 to 10, **characterized** in that the form of the form parts is adjustable.

1/4

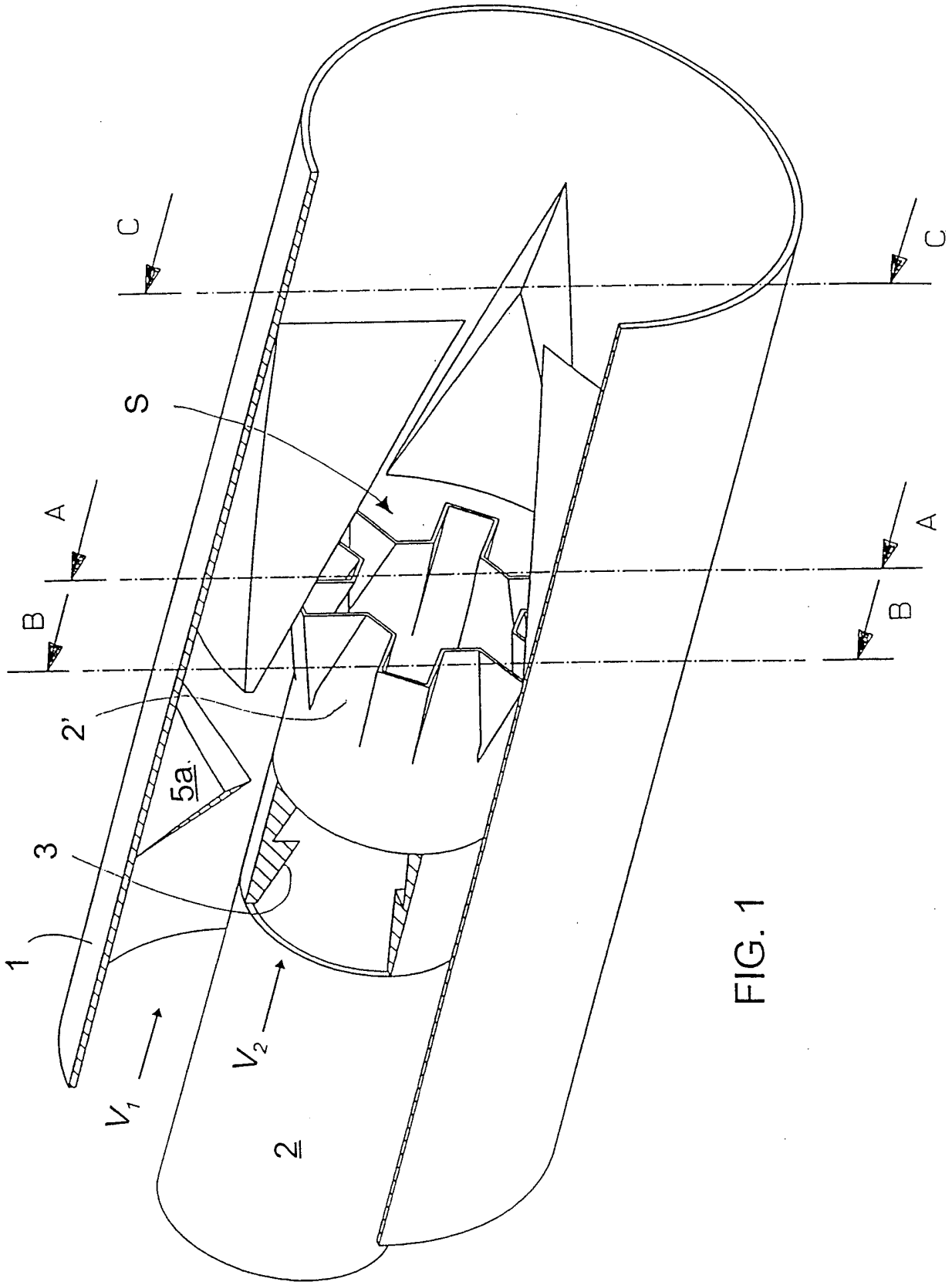

FIG. 1

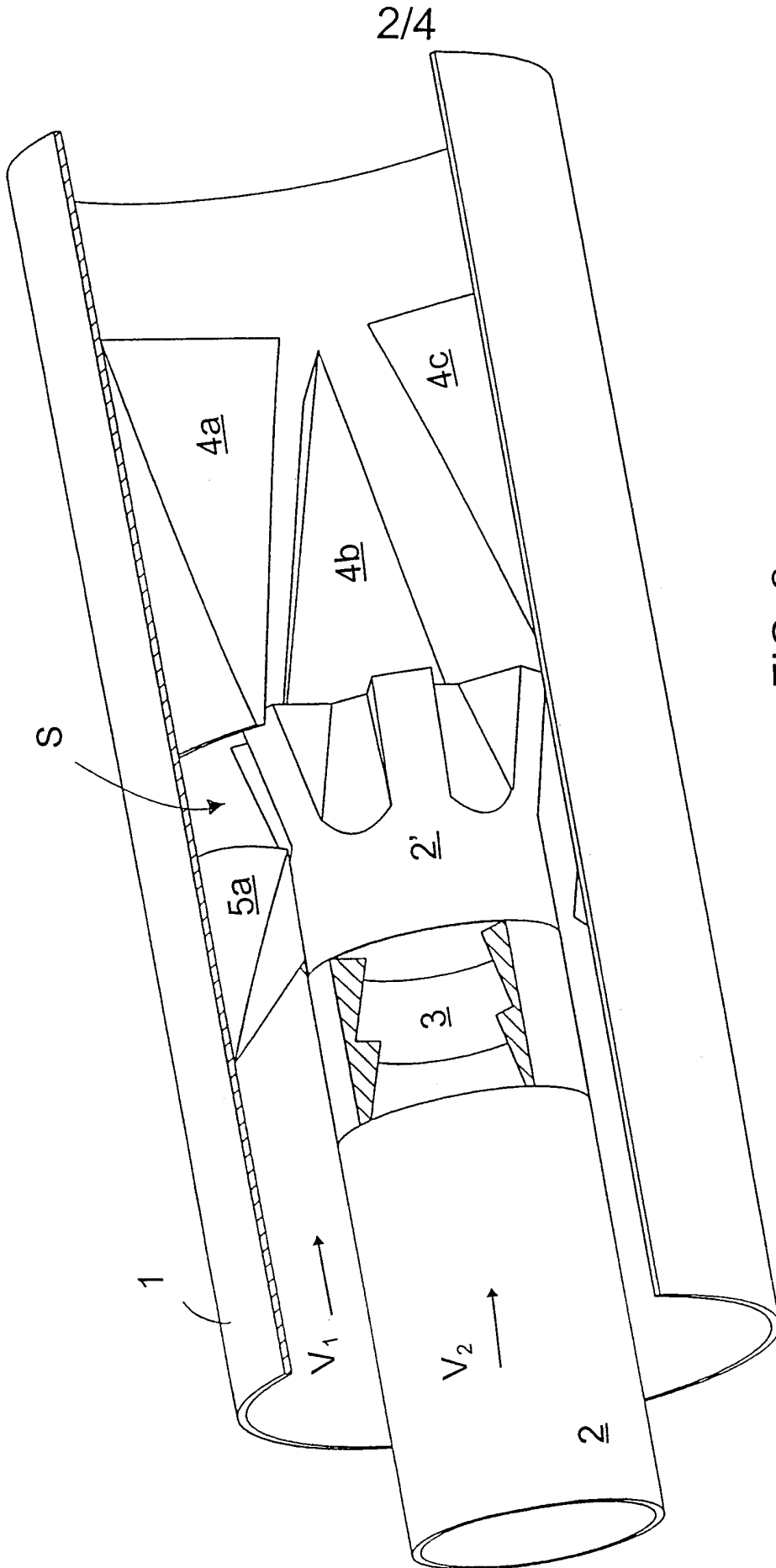

FIG. 2

3/4

SECTION A - A

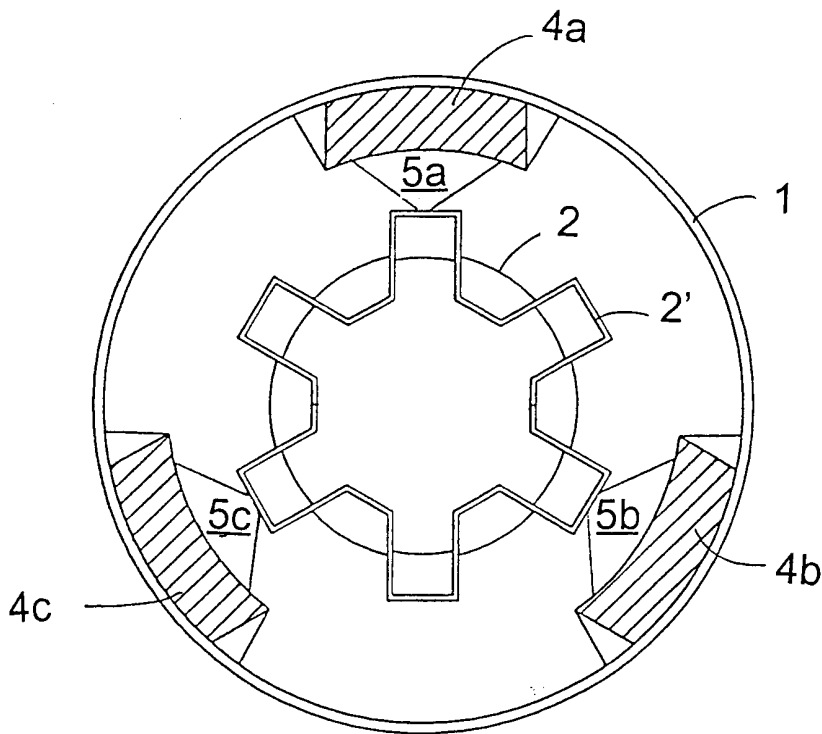

FIG. 3a

SECTION C - C

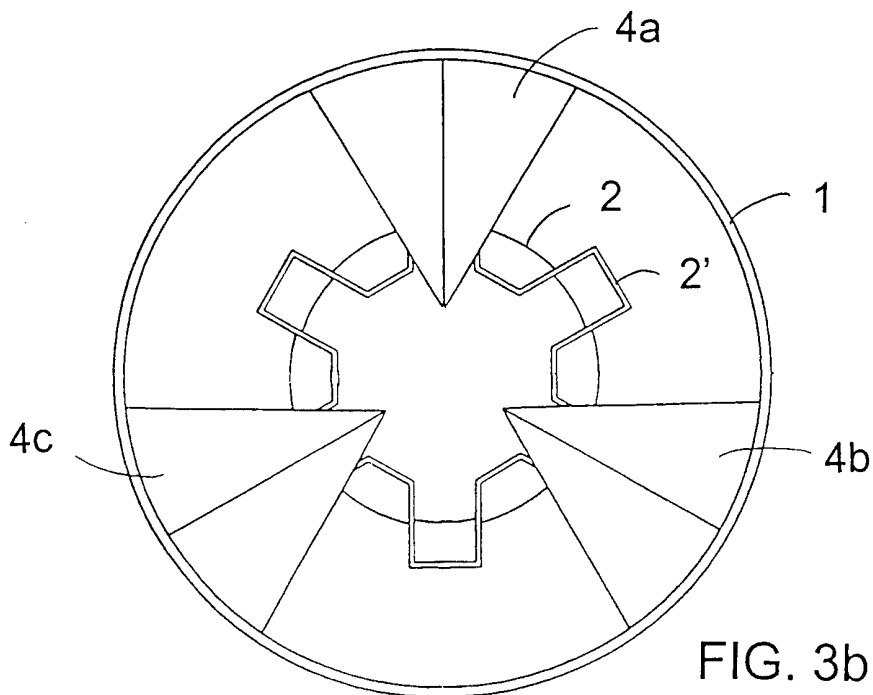

FIG. 3b

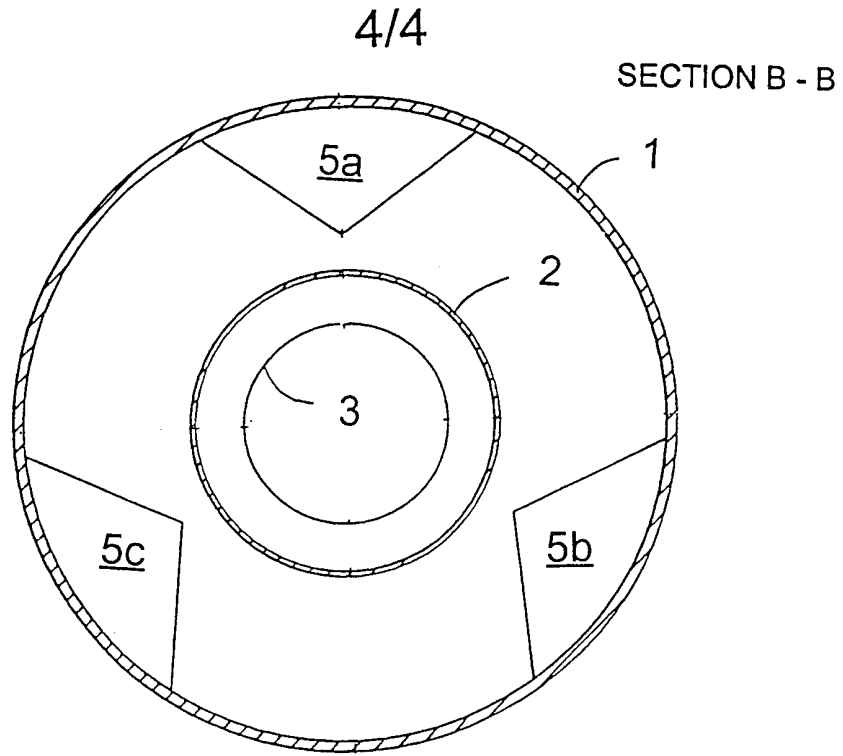

FIG. 3c

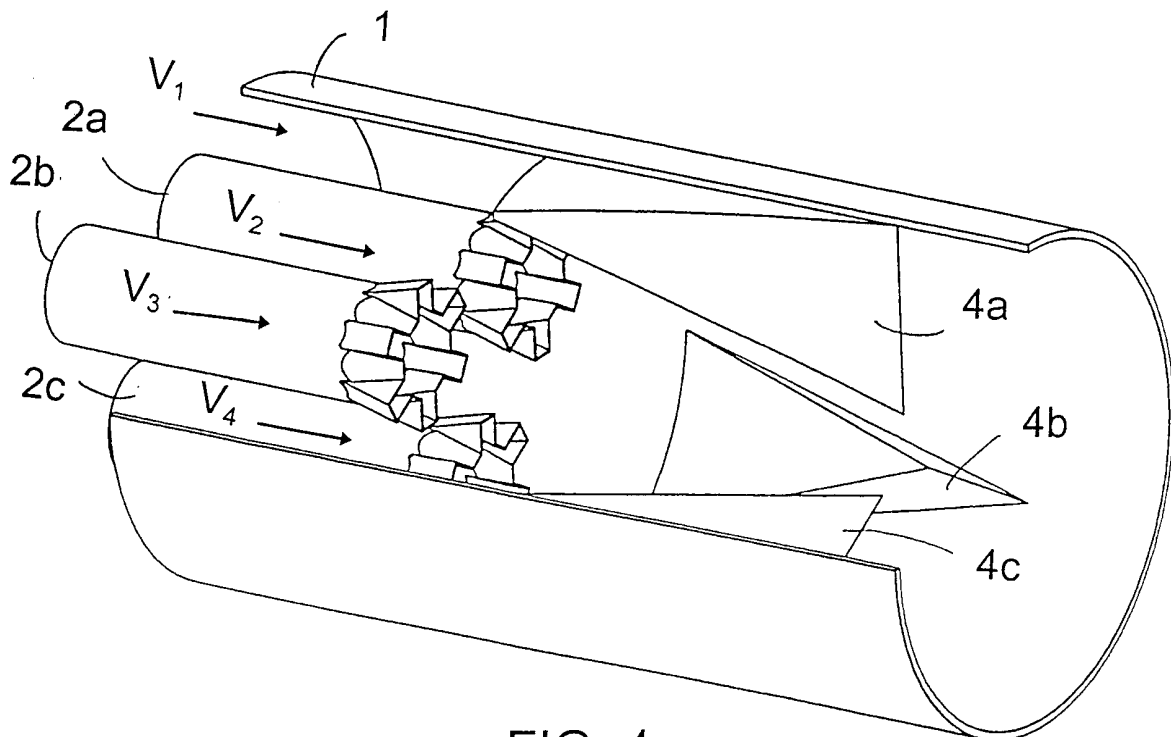

FIG. 4

# INTERNATIONAL SEARCH REPORT

International application No.

**PCT/FI 00/00872**

<b>A. CLASSIFICATION OF SUBJECT MATTER</b>				
<b>IPC7: D21F 1/06, D21F 1/08</b> According to International Patent Classification (IPC) or to both national classification and IPC				
<b>B. FIELDS SEARCHED</b>				
Minimum documentation searched (classification system followed by classification symbols)				
<b>IPC7: D21F</b>				
Documentation searched other than minimum documentation to the extent that such documents are included in the fields searched				
<b>SE,DK,FI,NO classes as above</b>				
Electronic data base consulted during the international search (name of data base and, where practicable, search terms used)				
<b>C. DOCUMENTS CONSIDERED TO BE RELEVANT</b>				
Category*	Citation of document, with indication, where appropriate, of the relevant passages	Relevant to claim No.		
P,X	<b>WO 9964666 A1 (VALMET CORPORATION),</b> <b>16 December 1999 (16.12.99)</b>  <p style="text-align: center;">--</p>	1,4		
A	<b>US 5030326 A (JEAN P. NOUS), 9 July 1991</b> <b>(09.07.91)</b>  <p style="text-align: center;">--</p>	1,4		
A	<b>US 3839145 A (KARL BUECKLE), 1 October 1974</b> <b>(01.10.74)</b>  <p style="text-align: center;">--</p> <p style="text-align: center;">-----</p>	1,4		
<input type="checkbox"/> Further documents are listed in the continuation of Box C. <input checked="" type="checkbox"/> See patent family annex.				
<table style="width: 100%; border: none;"> <tr> <td style="width: 50%; border: none;">                     * Special categories of cited documents:                      "A" document defining the general state of the art which is not considered to be of particular relevance                      "E" earlier application or patent but published on or after the international filing date                      "L" document which may throw doubts on priority claim(s) or which is cited to establish the publication date of another citation or other special reason (as specified)                      "O" document referring to an oral disclosure, use, exhibition or other means                      "P" document published prior to the international filing date but later than the priority date claimed                 </td> <td style="width: 50%; border: none;">                     "Γ" later document published after the international filing date or priority date and not in conflict with the application but cited to understand the principle or theory underlying the invention                      "X" document of particular relevance: the claimed invention cannot be considered novel or cannot be considered to involve an inventive step when the document is taken alone                      "Y" document of particular relevance: the claimed invention cannot be considered to involve an inventive step when the document is combined with one or more other such documents, such combination being obvious to a person skilled in the art                      "&amp;" document member of the same patent family                 </td> </tr> </table>			* Special categories of cited documents: "A" document defining the general state of the art which is not considered to be of particular relevance "E" earlier application or patent but published on or after the international filing date "L" document which may throw doubts on priority claim(s) or which is cited to establish the publication date of another citation or other special reason (as specified) "O" document referring to an oral disclosure, use, exhibition or other means "P" document published prior to the international filing date but later than the priority date claimed	"Γ" later document published after the international filing date or priority date and not in conflict with the application but cited to understand the principle or theory underlying the invention "X" document of particular relevance: the claimed invention cannot be considered novel or cannot be considered to involve an inventive step when the document is taken alone "Y" document of particular relevance: the claimed invention cannot be considered to involve an inventive step when the document is combined with one or more other such documents, such combination being obvious to a person skilled in the art "&" document member of the same patent family
* Special categories of cited documents: "A" document defining the general state of the art which is not considered to be of particular relevance "E" earlier application or patent but published on or after the international filing date "L" document which may throw doubts on priority claim(s) or which is cited to establish the publication date of another citation or other special reason (as specified) "O" document referring to an oral disclosure, use, exhibition or other means "P" document published prior to the international filing date but later than the priority date claimed	"Γ" later document published after the international filing date or priority date and not in conflict with the application but cited to understand the principle or theory underlying the invention "X" document of particular relevance: the claimed invention cannot be considered novel or cannot be considered to involve an inventive step when the document is taken alone "Y" document of particular relevance: the claimed invention cannot be considered to involve an inventive step when the document is combined with one or more other such documents, such combination being obvious to a person skilled in the art "&" document member of the same patent family			
Date of the actual completion of the international search	Date of mailing of the international search report			
<b>23 January 2001</b>	<b>29-01-2001</b>			
Name and mailing address of the ISA/ Swedish Patent Office Box 5055, S-102 42 STOCKHOLM Facsimile No. +46 8 666 02 86	Authorized officer  <b>Olov Jensen/ELY</b> Telephone No. +46 8 782 25 00			

# INTERNATIONAL SEARCH REPORT

Information on patent family members

27/12/00

International application No.

PCT/FI 00/00872

Patent document cited in search report	Publication date	Patent family member(s)	Publication date
WO 9964666 A1	16/12/99	AU 4517299 A FI 104384 B FI 981286 A	30/12/99 00/00/00 06/12/99
US 5030326 A	09/07/91	CA 1327471 A EP 0418445 A FR 2631353 A	08/03/94 27/03/91 17/11/89
US 3839145 A	01/10/74	DE 2045920 A,B,C FR 2107699 A SE 370556 B,C	23/03/72 05/05/72 21/10/74