



## INTERNATIONAL APPLICATION PUBLISHED UNDER THE PATENT COOPERATION TREATY (PCT)

<p>(51) International Patent Classification <sup>6</sup> : <b>A61F 11/00</b></p>	<p><b>A1</b></p>	<p>(11) International Publication Number: <b>WO 97/32551</b></p> <p>(43) International Publication Date: 12 September 1997 (12.09.97)</p>						
<p>(21) International Application Number: PCT/US97/03523</p> <p>(22) International Filing Date: 3 March 1997 (03.03.97)</p> <p>(30) Priority Data:</p> <table border="0"> <tr> <td>60/012,801</td> <td>4 March 1996 (04.03.96)</td> <td>US</td> </tr> <tr> <td>08/739,724</td> <td>7 November 1996 (07.11.96)</td> <td>US</td> </tr> </table> <p>(71) Applicant: ENERGY LIFE SYSTEMS CORPORATION [US/US]; 3303 Harbor Boulevard, Unit D-13, Costa Mesa, CA 92626 (US).</p> <p>(72) Inventors: HUSSEIN, Hany; 3303 Harbor Boulevard, Unit D-13, Costa Mesa, CA 92626 (US). SULEK, Stanislaw; 3303 Harbor Boulevard, Unit D-13, Costa Mesa, CA 92626 (US).</p> <p>(74) Agent: O'NEILL, James, G.; Suite 625, 3200 Bristol Street, Costa Mesa, CA 92626-1810 (US).</p>		60/012,801	4 March 1996 (04.03.96)	US	08/739,724	7 November 1996 (07.11.96)	US	<p>(81) Designated States: JP, European patent (AT, BE, CH, DE, DK, ES, FI, FR, GB, GR, IE, IT, LU, MC, NL, PT, SE).</p> <p><b>Published</b> <i>With international search report.</i> <i>With amended claims and statement.</i></p>
60/012,801	4 March 1996 (04.03.96)	US						
08/739,724	7 November 1996 (07.11.96)	US						
<p>(54) Title: DEVICE AND METHOD FOR TRANS MYOCARDIAL REVASCULARIZATION</p>								
<p>(57) Abstract</p>								
<p>A device (22) for insertion into the heart wall (25) suited for Trans Myocardial Revascularization (TMR) providing means for the delivery from the heart chamber into the heart wall (25) of blood nutrients. The device (22) has a hollow cylindrical body (21) containing a cavity and side ports (23) situated within that cavity. The cavity is in fluid communication with the heart chamber. The side ports (23) are in fluid communication with the heart wall (25). Distal and proximal end regions of the device (22) provide means (65) to secure the device in the heart wall. In addition, a system (36) for the insertion of the device (22) including a tubular body (40) and a needle point (43) is disclosed. A method for TMR includes the steps of displacement of myocardial tissue, or creation of a channel in that tissue, and placement into heart wall (25) of a stent (22) in the space generated by displaced tissue or channel.</p>								

**FOR THE PURPOSES OF INFORMATION ONLY**

Codes used to identify States party to the PCT on the front pages of pamphlets publishing international applications under the PCT.

AM	Armenia	GB	United Kingdom	MW	Malawi
AT	Austria	GE	Georgia	MX	Mexico
AU	Australia	GN	Guinea	NE	Niger
BB	Barbados	GR	Greece	NL	Netherlands
BE	Belgium	HU	Hungary	NO	Norway
BF	Burkina Faso	IE	Ireland	NZ	New Zealand
BG	Bulgaria	IT	Italy	PL	Poland
BJ	Benin	JP	Japan	PT	Portugal
BR	Brazil	KE	Kenya	RO	Romania
BY	Belarus	KG	Kyrgystan	RU	Russian Federation
CA	Canada	KP	Democratic People's Republic of Korea	SD	Sudan
CF	Central African Republic	KR	Republic of Korea	SE	Sweden
CG	Congo	KZ	Kazakhstan	SG	Singapore
CH	Switzerland	LI	Liechtenstein	SI	Slovenia
CI	Côte d'Ivoire	LK	Sri Lanka	SK	Slovakia
CM	Cameroon	LR	Liberia	SN	Senegal
CN	China	LT	Lithuania	SZ	Swaziland
CS	Czechoslovakia	LU	Luxembourg	TD	Chad
CZ	Czech Republic	LV	Larvia	TG	Togo
DE	Germany	MC	Monaco	TJ	Tajikistan
DK	Denmark	MD	Republic of Moldova	TT	Trinidad and Tobago
EE	Estonia	MG	Madagascar	UA	Ukraine
ES	Spain	ML	Mali	UG	Uganda
FI	Finland	MN	Mongolia	US	United States of America
FR	France	MR	Mauritania	UZ	Uzbekistan
GA	Gabon			VN	Viet Nam

**Device and Method for Trans Myocardial Revascularization**

5

**Assignee:** Energy Life Systems Corporation, Costa Mesa, California.

**10 Technical Field:**

This invention is generally directed to the fields of cardiac surgery and interventional cardiology, and particularly to mechanical devices and methods suited for improving blood flow to the heart muscle by Trans Myocardial Revascularization (TMR).

**15 Background of the invention:**

Symptomatic occlusive coronary artery disease that does not respond to medical or interventional treatment is a major challenge for cardiac surgeons and cardiologists. The discovery of sinusoidal communications within the myocardium (Wearns, 1933)  
**20** has motivated researchers to attempt various methods for myocardial revascularization based on the existence of this vascular mesh network. These methods aimed at the delivery of oxygenated blood to the vicinity of the sponge-like sinusoidal plexus in order to restore blood flow to the ischemic myocardium.  
**25** Several investigators have attempted to deliver oxygenated blood directly from the left ventricle into the myocardial sinusoids by employing needle acupuncture to create transmural channels. Trans Myocardial Revascularization (TMR) has been employed clinically (Mirhoseini, 1991) by utilizing a CO<sub>2</sub> laser system for  
**30** creating transmural channels in the left ventricular myocardium. These channels are typically 1 mm in diameter and extend throughout the wall thickness (15 to 20 mm) of the ventricle. It has been hypothesized that TMR works by providing a fluid conduit for oxygenated blood to flow from the endocardiac surface (heart  
**35** chamber) to the myocardium inner layers thus providing oxygenated blood to myocardial cells without requiring coronary circulation; as in reptiles. Animal studies in the canine model have

demonstrated the feasibility of this approach. In these studies, an increase in survival rate was demonstrated in dogs that had transmural channels and ligated coronary arteries.

While clinical studies have demonstrated improvements in patient status following TMR, histological studies indicate that the channels created for TMR tend to close shortly after the procedure. Randomized, prospective clinical trials are underway to examine the merit of TMR compared to medical treatment. In the meantime, research studies are being initiated to provide an understanding of the mechanism by which TMR actually works.

It would be desirable to develop means for maintaining the patency of TMR channels created within the myocardium. Furthermore, it would be desirable to create channels for TMR without requiring the use of an expensive and bulky laser system such as the currently available CO<sub>2</sub> laser system. This invention provides the desired means for producing trans myocardial channels that are likely to remain patent, and that do not require laser application for generating these channels.

Specifically, the objective of the present invention is to generate needle-made channels or space in the ischemic heart wall, and to place in these channels (or space) an array of stents in order to provide improved means for supplying blood nutrients to ischemic myocardial tissue. Nutrients flow to the stented channels from the ventricular cavity, and diffuse from the side ports of the stent to the myocardial tissue through the needle-made channels.

Our disclosed TMR approach of producing stented, needle-made, channels is supported by the recent scientific evidence (Whittaker et al, 1996) that needle-made transmural channels can protect ischemic tissue. Whittaker et al assessed myocardial response at two months to laser and needle-made channels in the rat model which has little native collateral circulation. They found that channels created by a needle can protect the heart against coronary artery occlusion, and that these channels provide greater protection to ischemic tissue than channels created by laser. The limitation of needle-made channels is early

closure (Pifarre, 1969). The disclosed stenting approach offers a possible solution to the early closure problem, while taking advantage of simple and effective needle-made channels for TMR.

5 **Summary of the invention:**

This invention provides stent and needle means for creating and maintaining a patent lumen in the diseased myocardium. This stent provides a conduit for the flow of blood nutrients from the ventricular chamber to the intramyocardial vascular network. This  
10 stent can be used as the sole therapy or as an adjunctive therapy to other forms of TMR.

Revascularization of the myocardium can be achieved and maintained by creating stented, needle-made, channels within the myocardial tissue. These channels can allow blood nutrients  
15 within the left ventricular cavity to find direct access to ischemic zones within the ventricular wall independent of access through the coronary arteries.

Various configurations of the stent are disclosed; including flexible and rigid stents, screw stents, sleeve stents, and  
20 others. Manual or powered means are disclosed for the placement of the stent in the heart wall. The proximal end of the stent terminates at the epicardial surface and provides mechanical closure means to prevent stent detachment and leakage of blood from the ventricle.

The stent is designed so as to maintain an adequate pressure gradient between the left ventricle and the myocardial tissue in order to maintain the flow from the ventricular cavity to the myocardial tissue of blood nutrients.

Furthermore, the disclosed TMR stent defines a cavity which can  
30 be pressurized during operation so as to enhance the flow of blood to myocardial tissue. Each stent can essentially operate as a mini-pump that is activated by myocardial contraction or by an external energy source.

35 Several embodiments of the stent are proposed, including the following: flexible spring, rigid sleeve, hollow screw, helical screw, and pumping (active) stent. The stent can be prestressed

or made from memory metal in order to minimize the size of the stent during the insertion process.

**Brief description of the drawings:**

- 5 In the drawings:  
Figure 1 is a cross-sectional view of a TMR stent inserted in a heart wall. The stent is configured as an expandable coil spring having an integral anchoring wire.
- 10 Figure 2 is a cross-sectional view of a TMR stent having the configuration of a rigid sleeve having side ports.  
Figure 3 is a cross-sectional view of a TMR stent having the configuration of a hollow screw with side ports.
- 15 Figure 4 is a cross-sectional view of a TMR stent having the configuration of a wire screw.
- Figure 5 is a cross sectional view of a flexible stent having an integral anchoring coil.
- 20 Figure 6 is a cross-sectional view of a TMR stent having the configuration of a miniature pump.
- 25 Figure 7 shows a device and method for insertion into the heart wall of a TMR stent.  
Figure 8 shows an alternate device and method for insertion into the heart wall of a TMR stent.
- 30 Figure 9 shows a catheter device and method utilizing a percutaneous access for insertion of a TMR stent into a needle-made space within the heart wall.
- 35 Figure 10 shows an alternate catheter device and method utilizing a percutaneous access for creating a channel in the heart wall, and for insertion in this channel of a TMR stent.

**Description of preferred embodiments:**

Figure 1 shows a flexible TMR stent having a coil spring body 21 defining a cavity 22 and spacing 23 between the turns of said spring body. In this embodiment, blood nutrients flow from the heart chamber 24 to the heart wall 25 by passage through the coil spring cavity 22 and spacing 23. An anchoring wire 65 secures the stent to the heart wall.

Figure 2 shows a TMR stent which comprises a tubular body 1, cavity 2, side ports 3, retainer 4, and closure 5. In this embodiment, blood nutrients 6 are transported from the heart chamber (ventricle) 7, through the cavity 1 and side ports 2, to the heart wall 8.

Figure 3 shows a TMR stent which is a hollow screw having a threaded body 9, cavity 10, side ports 11, closure 12, and slot 15. In this embodiment, blood nutrients flow from the heart chamber 13 to the heart wall 14 by passage through the cavity 10 and side ports 11.

Figure 4 shows a TMR stent which is a hollow wire screw having an elongated hollow coil body 16, side ports 17, and anchor 18. In this embodiment, blood nutrients flow from the heart chamber 19 to the heart wall 20 by passage through the hollow core of the wire 16 and side ports 17.

Figure 5 shows a flexible stent having a coil body 26 and an anchoring coil 27 which is an integral part of the stent. The anchoring coil prevents detachment of the stent from the heart wall.

Figure 6 shows a TMR device having a cylindrical body 28 defining a cavity 29. A valve 30, pumping element 31, and side ports 32 are situated within the cavity 29. In this embodiment, blood nutrients flow from the heart chamber 33 to the pumping cavity 29. The valve 30 is activated and the pumping element 31 operates

to displace the blood from the pumping cavity 29 through side ports 32 to the heart wall 34.

5 Figure 7 shows the construction and method of use of a delivery device for creating a pathway in the heart wall and for placement of a myocardial stent in this pathway. In this figure, a needle obturator 36 carries a stent 35 having an anchoring wire 37. The obturator and stent are inserted through the heart wall 38 until the endocardiac surface is reached. Additional improvements  
10 include a channel 66 that is placed in the obturator body to provide indication that the obturator's distal end 67 has crossed the endocardiac surface 39.

15 Figure 8 shows the construction and method of operation of an alternate delivery system for placement in the heart wall of a TMR device. Figure 8A shows a delivery system having a pin 40 and handle 41 having a locking device 42. An obturator 43 is mounted in the pin 40. The obturator 43 has a recess 44 (Figure 8B) to engage the distal end of a TMR device 45. The pin 40 has a recess  
20 46 (Figure 8B) to engage the proximal end of a TMR device 45. The method of use involves the placement of a TMR device 45 over an obturator 43. The pin 47 is then rotated to create a radial stress on the TMR device 48 (Figure 8D). The pin 47 is locked into the handle 49 (Figure 8C). Advancement through the heart wall  
25 50 of the obturator and TMR device is achieved by pressing the obturator through the heart wall (Figures 8E, 8F). The pin 51 is released from handle 52 by withdrawing the locking device 53 (Figures 8G, 8H). This causes the TMR device 54 to be released from the obturator 55. The obturator 55 is then pulled back from  
30 the heart wall 56 leaving the TMR device 57 imbedded in the heart wall (Figure 8I).

35 Figure 9 shows a catheter 58 having a slidable wire 59 which terminates at its distal end into a needle point 60. A stent 61 is mounted proximal to the needle point. Advancing the needle spreads the heart wall tissue and positions the stent into that



tissue. Withdrawal of the needle releases the stent in the heart wall.

5 Figure 10 shows a catheter 62 which incorporates a slidable wire 63 that terminates at its distal end into a drill or other mechanical attachment for making holes in the heart wall tissue. A stent 64 is mounted proximal to the drilling tool on the slidable wire. Advancing the drilling tool creates a channel in the tissue and positions the stent in this channel. Withdrawal  
10 of the drilling tool releases the stent in the heart wall.

The disclosed TMR device is expected to incorporate a cavity having a diameter in the range of 1-5 millimeters and a length in the range of 10-30 millimeters. The body of the TMR device is  
15 made of a bio-compatible material that resists clot formation; such as stainless steel. The TMR device may also be coated with a material, such as gold or carbon, that further reduces thrombus formation at the surface of the TMR device. The TMR device may also be made from carbon, gold, platinum, or other suitable  
20 materials.

The number of TMR devices used for each patient depends on the size of the device and the surface area of the heart segment that is being revascularized. For example, a small segment may require  
25 only one TMR device while a large segment may require 10 TMR devices to be implanted in the heart wall.

**We claim:**

1. A device suitable for Trans Myocardial Revascularization (TMR), wherein the improvement comprises a body which can be implanted in a heart wall in order to provide a conduit for the flow of blood nutrients from a heart chamber to said heart wall.
2. The device in accordance with claim 1 wherein said body includes a cavity that is in fluid communication with a heart chamber.
3. The device in accordance with claim 2 wherein said device is made from a material that resists thrombosis.
4. The device in accordance with claim 2 wherein said cavity is coated with a material that resists thrombosis.
5. The device in accordance with claim 2 wherein said body is made from a memory metal alloy.
6. A device in accordance with claim 1 wherein said body includes a cavity that is in fluid communication with a portion of the heart wall.
7. The device in accordance with claim 1 wherein said body is rigid.
8. The device in accordance with claim 1 wherein said body is flexible.
9. The device in accordance with claim 1 wherein said body is expandable.
10. The device in accordance with claim 1 wherein said body is tubular.

11. The device in accordance with claim 10 wherein said tubular body is a rigid sleeve having at least one side port.
12. The device in accordance with claim 10 wherein said tubular body is a spring.
13. The device in accordance with claim 10 wherein said tubular body is a hollow screw having at least one side port.
14. The device in accordance with claim 10 wherein said tubular body is a hollow wire screw having at least one side port.
15. The device in accordance with claim 1 wherein said body includes a cavity and said cavity terminates at one end into a closure means.
16. The device in accordance with claim 1 wherein said body includes means for securing said device to the heart wall.
17. The device in accordance with claim 1, further including valve means in said body.
18. The device in accordance with claim 1, further including pump means in said body.
19. A method for performing TMR consisting of the following steps:
  - a. Identifying a portion of a heart wall that is targeted for treatment by TMR;
  - b. Obtaining access to the heart wall; and
  - c. Inserting a TMR device into the heart wall.

20. A method for performing TMR consisting of the following steps:
- a. Identifying a portion of a heart wall that is targeted for treatment by TMR;
  - b. Obtaining access to the heart wall;
  - 5 c. Creating a channel in the heart wall; and
  - d. Inserting a TMR device into the heart wall.
21. A delivery system suitable for delivery to a heart wall of a TMR device, characterized in that said delivery system consists of the following:
- a. Means to carry said TMR device;
  - b. Means to penetrate the heart wall; and
  - 5 c. Means to release said TMR device within the heart wall.
22. A method for the placement in a heart wall of a suitable TMR device, said method including the step of insertion of said TMR device into the heart wall.
23. A method in accordance with claim 22 wherein said insertion is accomplished by turning the TMR device into the heart wall.
24. A method in accordance with claim 22 wherein said insertion is accomplished by pushing the TMR device into the heart wall.
25. A method in accordance with claim 22 wherein said insertion is performed by employing mechanical means.
26. A method in accordance with claim 22 wherein said insertion is facilitated by the use of obturator means for spreading the heart wall during said insertion of said TMR device.

27. A method in accordance with claim 22 wherein said insertion is facilitated by the release into the heart wall of an expandable pre-stressed TMR device.
28. A delivery device for inserting a TMR stent into a heart wall; said delivery device characterized in that a tubular body carries the stent and inserts said stent in the heart wall.
29. The delivery device in accordance with claim 28 wherein said delivery device has a needle point for creating a pathway in the heart wall.
30. The delivery device in accordance with claim 28 wherein said delivery device has means for insertion of the stent into said pathway.
31. The delivery device in accordance with claim 28 wherein said tubular body has proximal and distal ends, and said delivery device has a channel that is in fluid communication with said proximal and distal ends.

**AMENDED CLAIMS**

[received by the International Bureau on 5 August 1997 (05.08.97);  
original claims 1-18 amended; remaining claims  
unchanged (3 pages)]

1. A stent for Trans Myocardial Revascularization in a portion of a heart wall wherein the improvement comprises: an elongated body; the elongated body being adapted to be secured in an opening formed in a heart wall and including means for holding the elongated body in place in the heart wall opening.
2. The stent of claim 1 wherein the elongated body has an outside surface and an inside surface, and includes an internal cavity bound by the inside surface.
3. The stent of claim 2, further including at least one opening connecting the internal cavity to the outside surface.
4. The stent of claim 1 wherein the elongated tubular body is a rigid sleeve with at least one opening comprising a side port therein.
5. The stent of claim 4 wherein the rigid sleeve has a plurality of side ports therein.
6. The stent of claim 1 wherein the elongated tubular body is a spring.
7. The stent of claim 1 wherein the elongated tubular body is a hollow screw with at least one opening comprising a side port in the hollow screw.
8. The stent of claim 7 wherein the hollow screw has a plurality of side ports therein.
9. The stent of claim 1 wherein the elongated tubular body is a hollow wire coil with at least one opening comprising a side port therein.

10. The stent of claim 9 wherein the hollow wire coil has a plurality of side ports therein.
11. The stent of claim 1 wherein the elongated tubular body has an internal cavity with two ends, and one of the two ends closes the cavity at that end.
12. The stent of claim 1 wherein the means for securing the elongated body in place in an opening comprises an integral anchoring means.
13. The stent of claim 12 wherein the elongated body is a spring having two ends and the integral anchoring means comprises a stem and an arm secured to one of the two ends.
14. The stent of claim 12 wherein the elongated body is a rigid sleeve having two ends with a plurality of openings extending through the rigid sleeve; and the integral anchoring means comprises a retaining means formed at one of the two ends.
15. The stent of claim 12 wherein the elongated body is rigid and has two ends with a screw thread being formed on the outside surface thereof; and a plurality of openings are formed in the elongated rigid body extending from the internal cavity to the outside surface.
16. The stent of claim 15 wherein the screw thread formed on the outside surface is the integral anchoring means.

17. The stent of claim 12 wherein the elongated body is a hollow wire coil having two ends and a plurality of openings formed therein; and the integral anchoring means comprises a mechanical anchor formed at one of the two ends.
18. The stent of claim 1, further including valve means and pump means secured in the elongated body.
19. A method for performing TMR consisting of the following steps:
- a. Identifying a portion of a heart wall that is targeted for treatment by TMR;
  - b. Obtaining access to the heart wall; and
  - c. Inserting a TMR device into the heart wall.

5



**STATEMENT UNDER ARTICLE 19**

The replacement pages 8, 9 and 9A contain new claims 1 through 18, to replace old claims 1 through 18. Claim 1, the only independent claim, now specifically claims an elongated body, and that the elongated body is adapted to be secured in an opening formed in a heart wall, and includes means for holding the elongated body in place in the heart wall opening.

Claims 2 through 18 are dependent on claim 1, and have been modified to include further specific structure.

These replacement claims 1 through 18 are felt to more properly set forth the inventive stent, in view of the cited patents included with the Notification of the 24th of April. Nothing new had been added by these new claims 1 through 18, since the specification as filed, and the drawings discuss and show all of the claimed features.

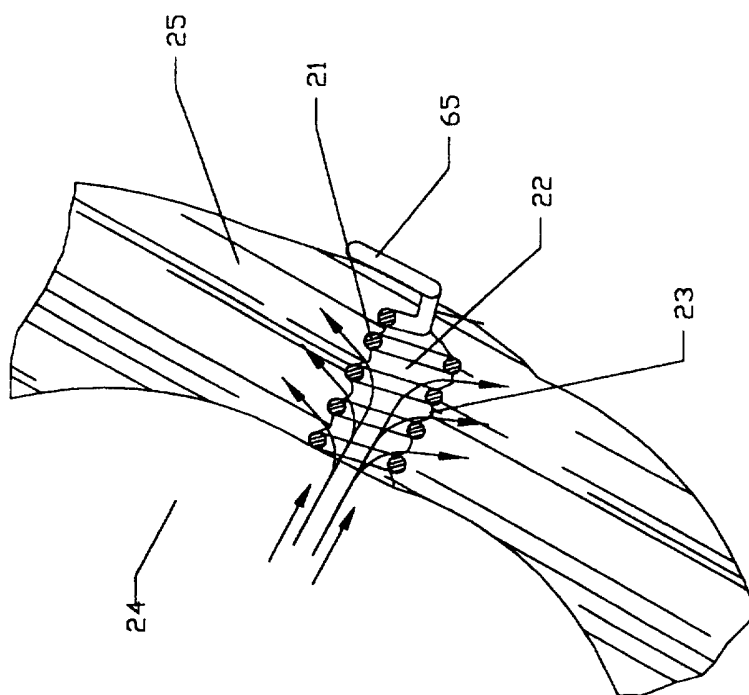

FIGURE 1

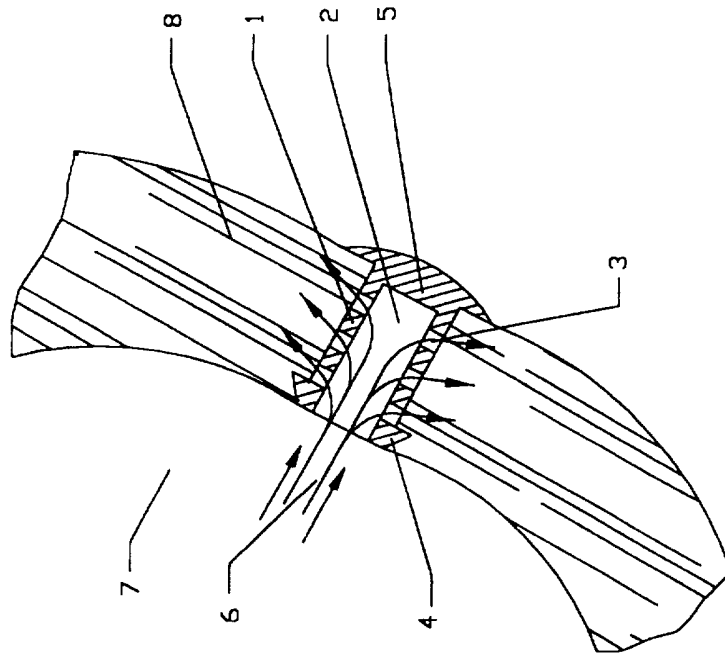

FIGURE 2

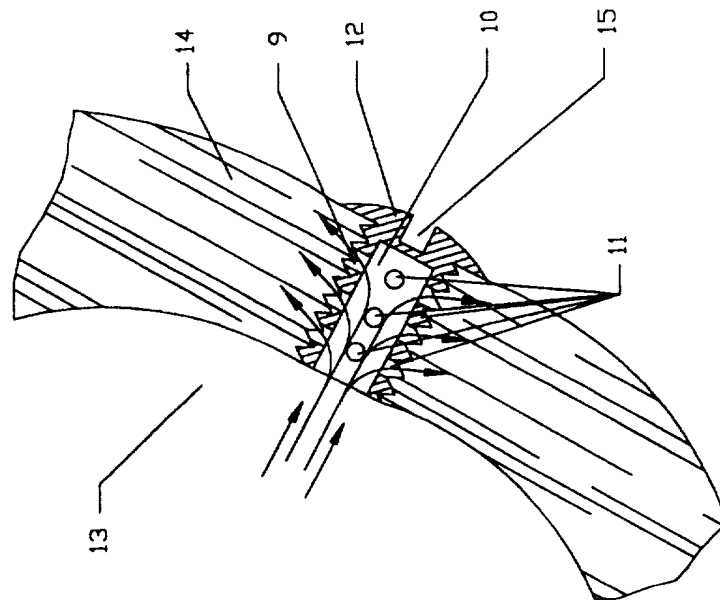

FIGURE 3

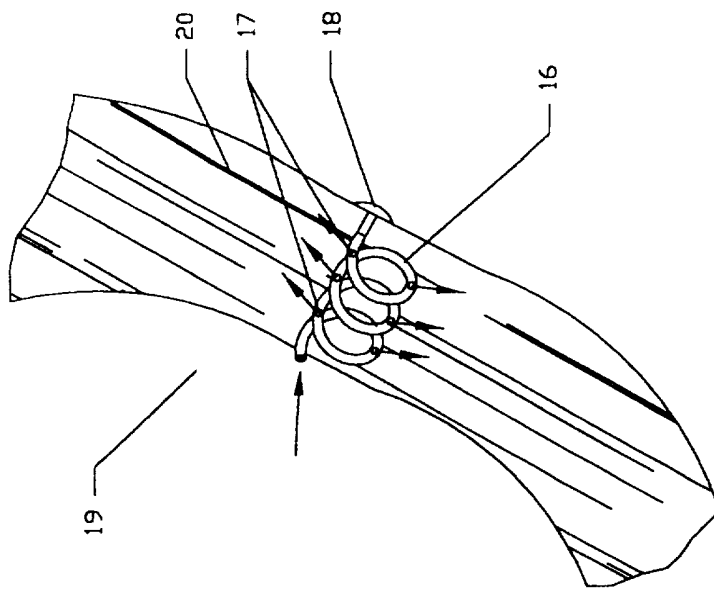

FIGURE 4

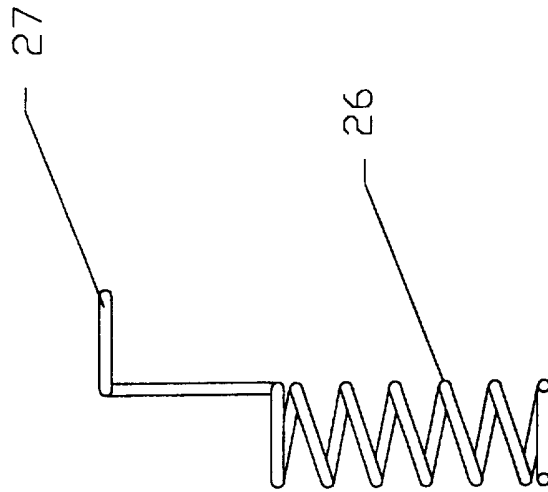

FIGURE 5

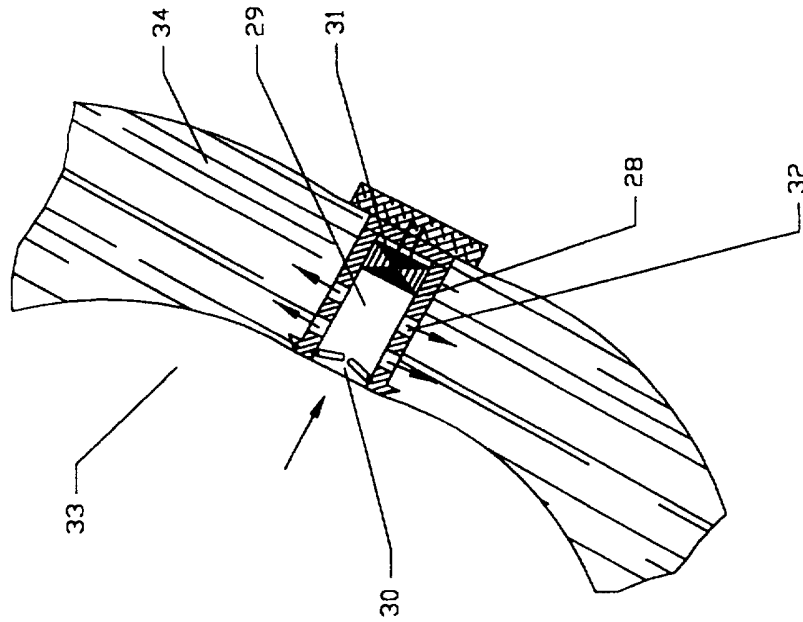

FIGURE 6

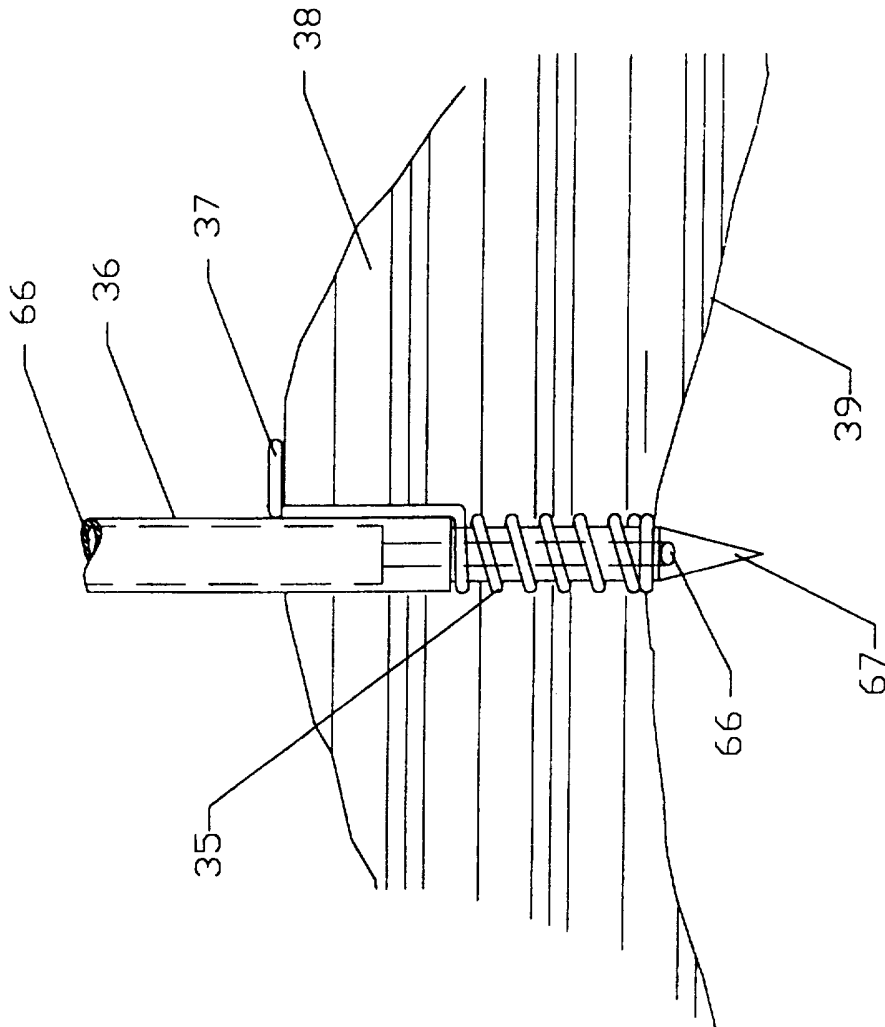

FIGURE 7



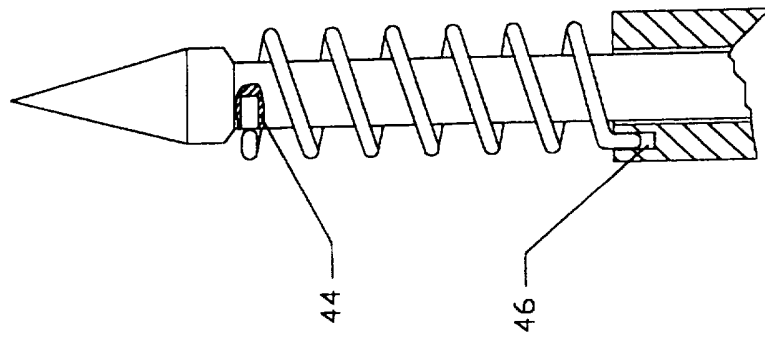

FIGURE 8B

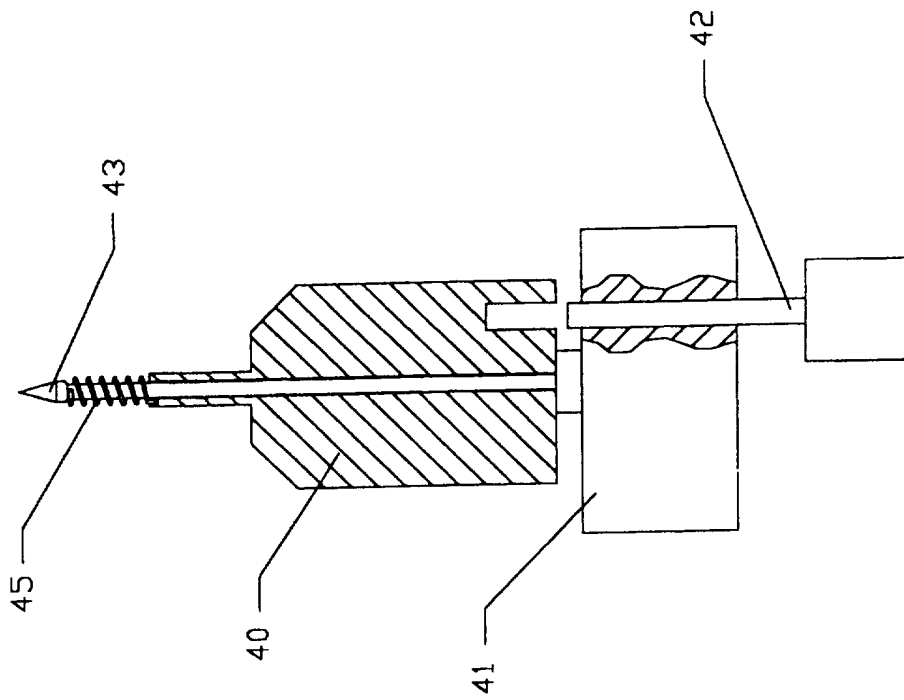

FIGURE 8A

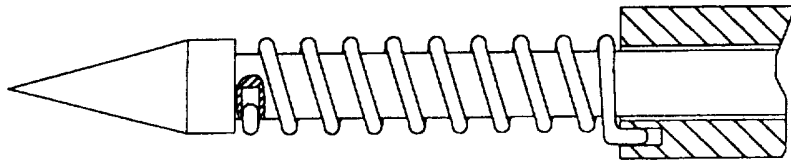

FIGURE 8D

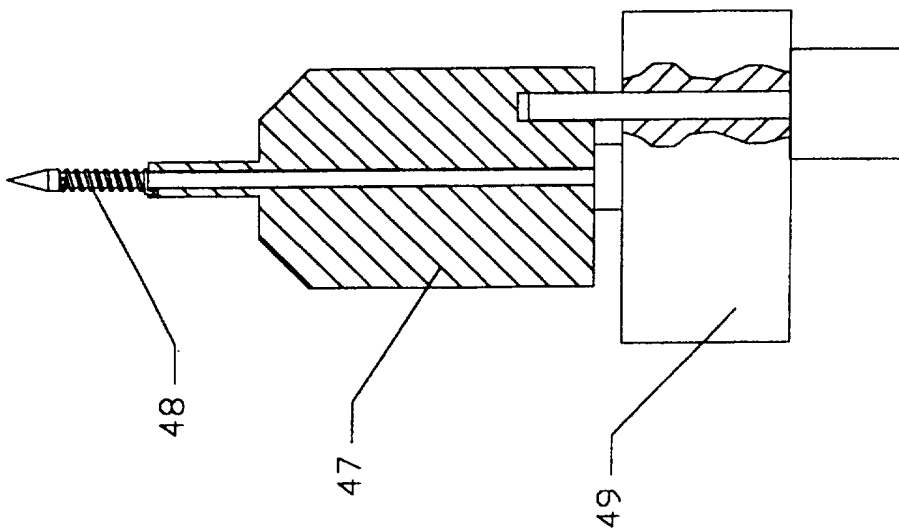

FIGURE 8C

10/13

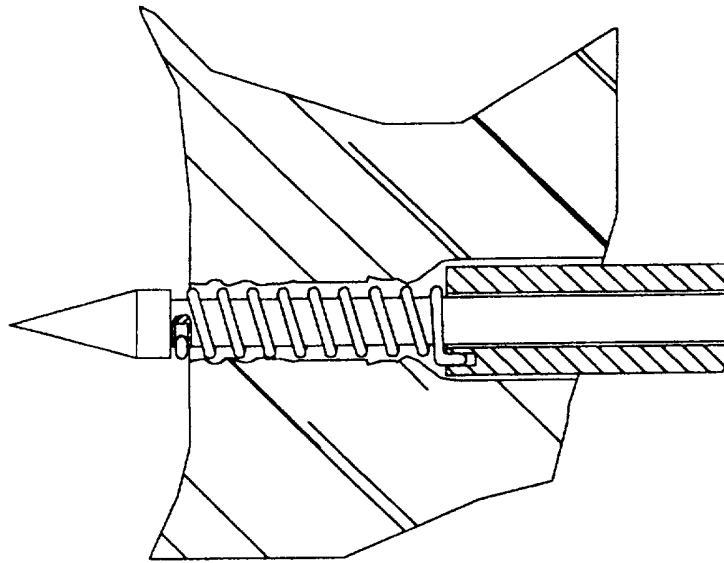

FIGURE 8F

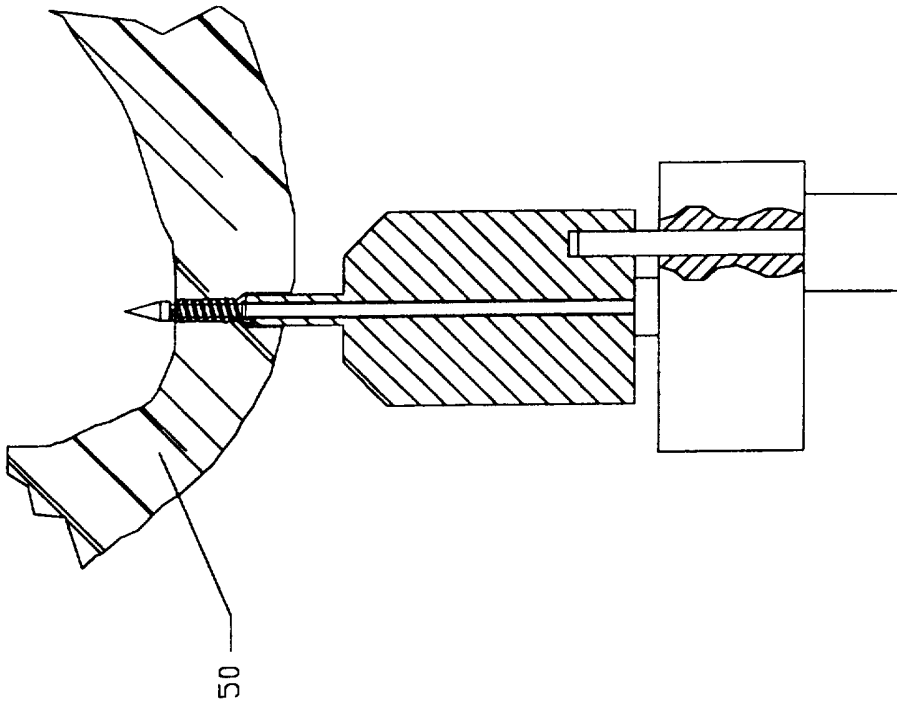
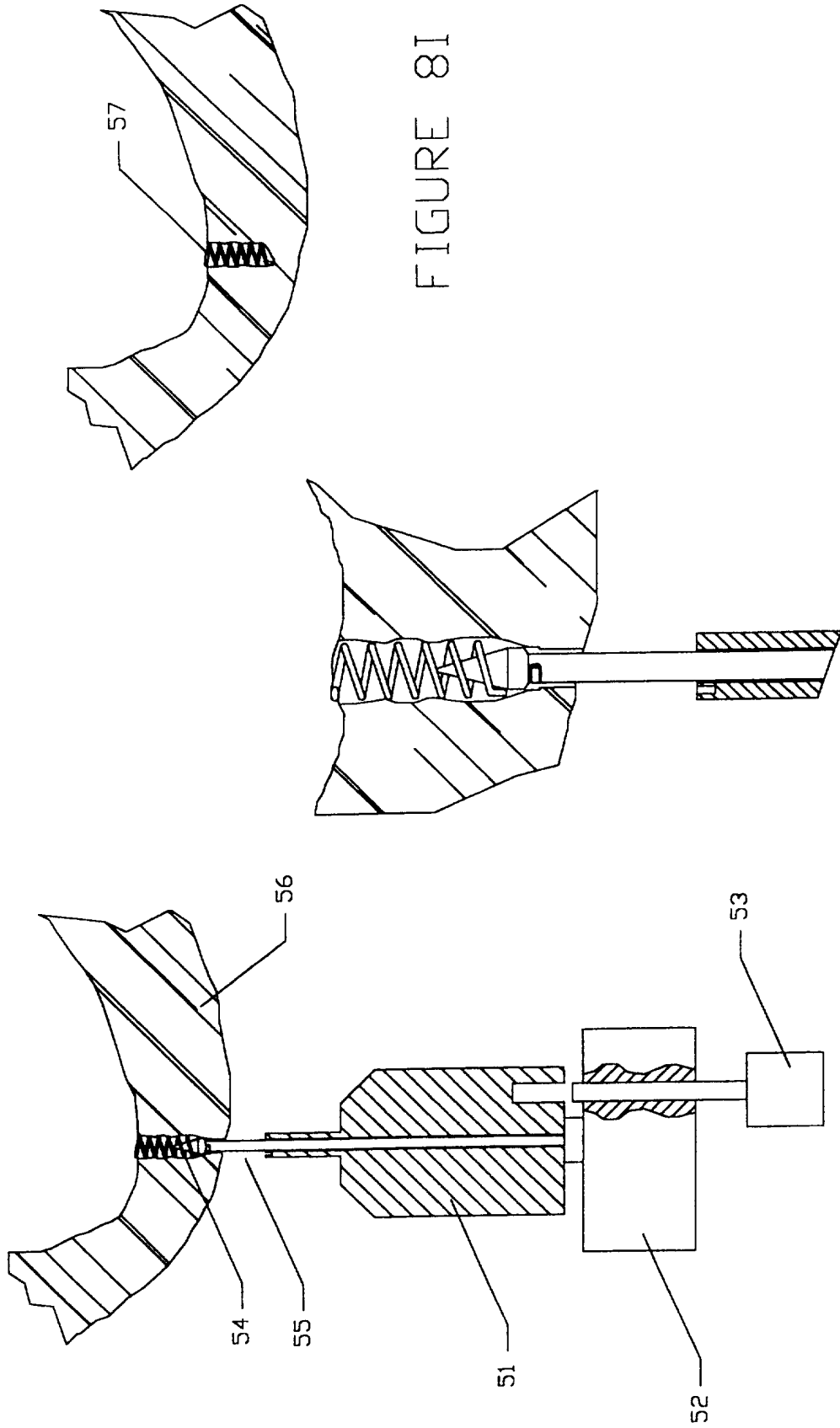

FIGURE 8E



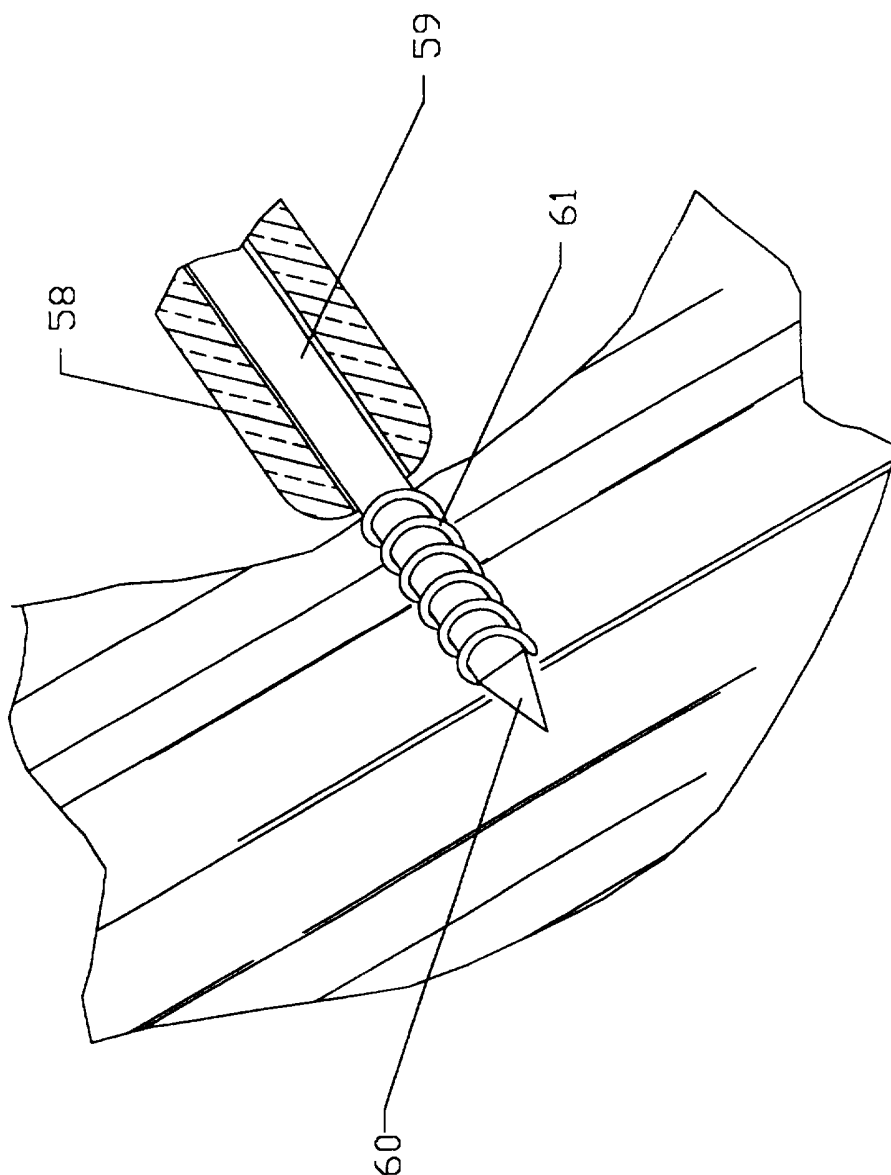

FIGURE 9

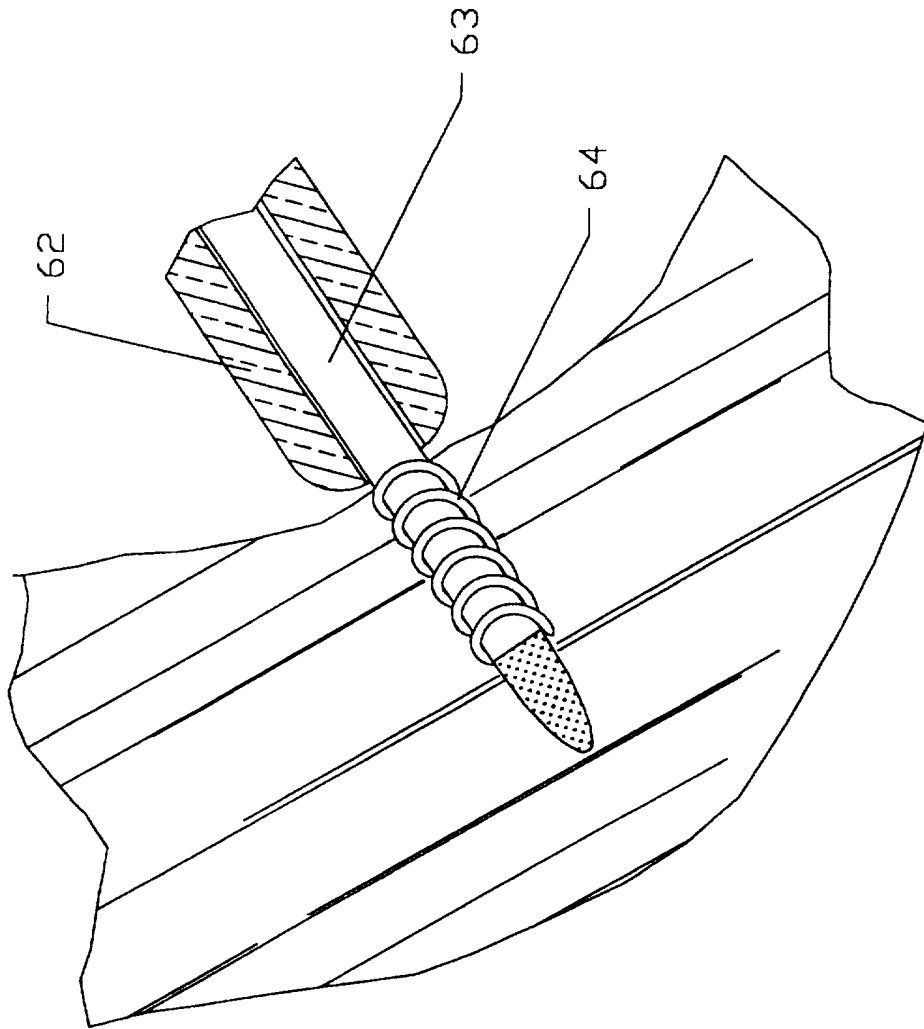

FIGURE 10

INTERNATIONAL SEARCH REPORT

International application No.  
PCT/US97/03523

<b>A. CLASSIFICATION OF SUBJECT MATTER</b>																				
IPC(6) :A61F 11/00 US CL :606/108 According to International Patent Classification (IPC) or to both national classification and IPC																				
<b>B. FIELDS SEARCHED</b>																				
Minimum documentation searched (classification system followed by classification symbols) U.S. : 606/108, 195, 198, 185, 215; 604/164, 165, 264; 623/11, 12.																				
Documentation searched other than minimum documentation to the extent that such documents are included in the fields searched																				
Electronic data base consulted during the international search (name of data base and, where practicable, search terms used) APS search terms: heart (2a)wall, stent or graft, needle or trocar, thrombosis, pump, trans myocardial and revascularization.																				
<b>C. DOCUMENTS CONSIDERED TO BE RELEVANT</b>																				
Category*	Citation of document, with indication, where appropriate, of the relevant passages	Relevant to claim No.																		
X ---- Y	US 5,287,861 A (Wilk) 22 February 1994, see the entire document.	1-2, 5-6, 8-10, 19-22, and 25-31. ----- 3-4, 7, 11-14, 15-17, and 23-24.																		
X -- Y	US 5,380,299 A (Fearnot et al) 10 January 1995, see the entire document.	1, 4. ----- 3																		
X	US 4,477,930 A (Totten et al) 10 October 1984, see the entire document.	1, 15-17.																		
X	US 5,376,114 A (Jarvik) 27 December 1994, see the entire document.	1, 18.																		
<input checked="" type="checkbox"/> Further documents are listed in the continuation of Box C. <input type="checkbox"/> See patent family annex.																				
<table border="0"> <tr> <td>* Special categories of cited documents:</td> <td>"T"</td> <td>later document published after the international filing date or priority date and not in conflict with the application but cited to understand the principle or theory underlying the invention</td> </tr> <tr> <td>"A" document defining the general state of the art which is not considered to be of particular relevance</td> <td>"X"</td> <td>document of particular relevance; the claimed invention cannot be considered novel or cannot be considered to involve an inventive step when the document is taken alone</td> </tr> <tr> <td>"E" earlier document published on or after the international filing date</td> <td>"Y"</td> <td>document of particular relevance; the claimed invention cannot be considered to involve an inventive step when the document is combined with one or more other such documents, such combination being obvious to a person skilled in the art</td> </tr> <tr> <td>"L" document which may throw doubts on priority claim(s) or which is cited to establish the publication date of another citation or other special reason (as specified)</td> <td>"&amp;"</td> <td>document member of the same patent family</td> </tr> <tr> <td>"O" document referring to an oral disclosure, use, exhibition or other means</td> <td></td> <td></td> </tr> <tr> <td>"P" document published prior to the international filing date but later than the priority date claimed</td> <td></td> <td></td> </tr> </table>			* Special categories of cited documents:	"T"	later document published after the international filing date or priority date and not in conflict with the application but cited to understand the principle or theory underlying the invention	"A" document defining the general state of the art which is not considered to be of particular relevance	"X"	document of particular relevance; the claimed invention cannot be considered novel or cannot be considered to involve an inventive step when the document is taken alone	"E" earlier document published on or after the international filing date	"Y"	document of particular relevance; the claimed invention cannot be considered to involve an inventive step when the document is combined with one or more other such documents, such combination being obvious to a person skilled in the art	"L" document which may throw doubts on priority claim(s) or which is cited to establish the publication date of another citation or other special reason (as specified)	"&"	document member of the same patent family	"O" document referring to an oral disclosure, use, exhibition or other means			"P" document published prior to the international filing date but later than the priority date claimed		
* Special categories of cited documents:	"T"	later document published after the international filing date or priority date and not in conflict with the application but cited to understand the principle or theory underlying the invention																		
"A" document defining the general state of the art which is not considered to be of particular relevance	"X"	document of particular relevance; the claimed invention cannot be considered novel or cannot be considered to involve an inventive step when the document is taken alone																		
"E" earlier document published on or after the international filing date	"Y"	document of particular relevance; the claimed invention cannot be considered to involve an inventive step when the document is combined with one or more other such documents, such combination being obvious to a person skilled in the art																		
"L" document which may throw doubts on priority claim(s) or which is cited to establish the publication date of another citation or other special reason (as specified)	"&"	document member of the same patent family																		
"O" document referring to an oral disclosure, use, exhibition or other means																				
"P" document published prior to the international filing date but later than the priority date claimed																				
Date of the actual completion of the international search 09 MAY 1997	Date of mailing of the international search report 24 JUN 1997																			
Name and mailing address of the ISA/US Commissioner of Patents and Trademarks Box PCT Washington, D.C. 20231 Facsimile No. (703) 305-3230	Authorized officer <i>Justine Yu</i> Justine Yu Telephone No. (703) 308-2675																			

INTERNATIONAL SEARCH REPORT

International application No.  
PCT/US97/03523

C (Continuation). DOCUMENTS CONSIDERED TO BE RELEVANT

Category*	Citation of document, with indication, where appropriate, of the relevant passages	Relevant to claim No.
Y	US 5,354,309 A (Schnepp-Pesch et al) 11 October 1994, see the entire document.	7, 11-14.