

D. TRACY & G. HOBBS.
SEWING MACHINE.

No. 40,000.

Patented Sept. 15, 1863.

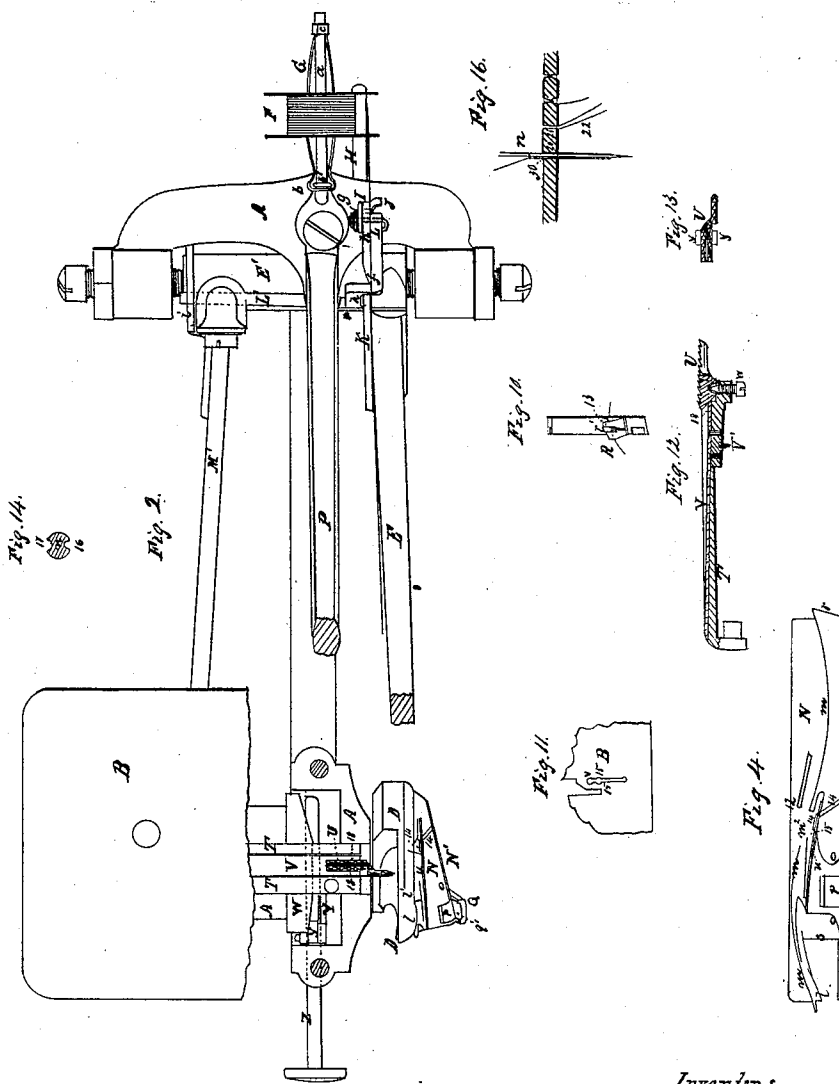

Witnesses.
Henry Chapin
O. F. Harris

Inventors.
Dwight Tracy
G. Hobbs

D. TRACY & G. HOBBS.
SEWING MACHINE.

No. 40,000.

Patented Sept. 15, 1863.

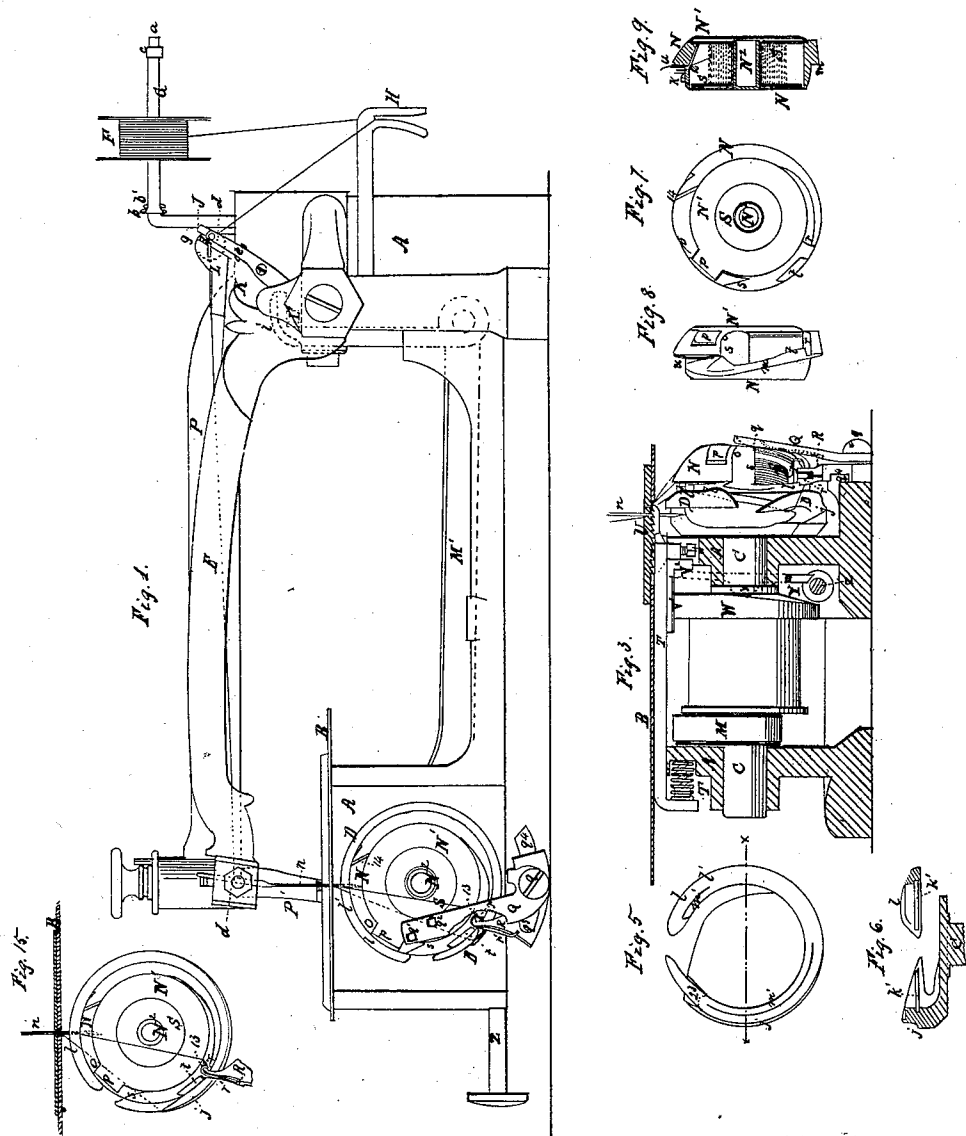

Witnesses
Henry Chapin
O. H. Harris

Inventors.
Dwight Tracy
Geo. Hobbs.

UNITED STATES PATENT OFFICE.

DWIGHT TRACY AND GEORGE HOBBS, OF WORCESTER, MASSACHUSETTS,
ASSIGNORS TO DWIGHT TRACY, AFORESAID.

IMPROVEMENT IN SEWING-MACHINES.

Specification forming part of Letters Patent No. 40,000, dated September 15, 1863.

To all whom it may concern:

Be it known that we, DWIGHT TRACY and GEORGE HOBBS, both of Worcester, in the county of Worcester and State of Massachusetts, have invented certain new and useful Improvements in Sewing-Machines; and we do hereby declare that the following is a full, clear, and exact description of the same, reference being had to the accompanying drawings, forming part of this specification, in which—

Figure 1 is a side view elevation of our improved sewing-machine. Fig. 2 is a top view of the same with part of the work-plate, the presser, and the needle-arm broken away to show the parts beneath it. Fig. 3 is a front view of the same with the framing and cloth-plate in section. Fig. 4 shows the rim of the spool-case projected on a plane. Figs. 5 and 6 are views of the rotating hook. Figs. 7, 8, and 9 are different views of the spool-case. Fig. 10 is a top view of the loop-check. Fig. 11 is a plan of the portion of the work-plate through which the needle and thread pass. Fig. 12 is a longitudinal vertical sectional view of the feed bar and dog and their appendages. Fig. 13 is a top view of the dog detached from the feed-bar. Fig. 14 is a transverse section of the needle on a scale much longer than natural size. Fig. 15 is a face view of the rotating hook, spool-case, and check. Fig. 16 is a diagram illustrative of the action of the needle on drawing the thread from the upper spool.

Similar letters and numbers of reference indicate the parts in all the figures.

The subject-matter of our invention consists of several improvements in sewing-machines, a part of which improvements are more particularly applicable to machines which make the "lock-stitch," so called, by means of a needle and rotating hook and bobbins, similar to what is known as the "Wheeler & Wilson machine," and other improvements, which are more or less applicable to sewing-machines of other descriptions.

Our first improvement relates to the employment, in a sewing-machine which forms the stitches by means of a needle and rotating hook and bobbin, or their equivalents, of certain new devices so combined and arranged in the machine that we are able to accomplish in such a machine the same purpose that is

accomplished in a machine that uses a needle and shuttle, by means of certain improvements which are the subject of Letters Patent to Dwight Tracy, dated September 11, 1860, No. 30,012—that is, to deliver to the needle, when it is inserted into the cloth or other material, the proper length of thread at each stitch necessary to make the stitch, corresponding to the thickness of material to be sewed and the length of the stitches, however they may vary, and to draw up such measured length of thread to complete the stitch by a positive motion, by which means the machine is adapted to the various conditions of work without adjustment by the operator. In "shuttle-machines," so called, where one stitch is completed before the next is commenced, the free thread between the eye of the needle and the last stitch made is all upon the needle side of the cloth; but when the stitch is made with the needle and rotating hook, as in the Wheeler & Wilson machine, one stitch is not completed until after the next is commenced, and a part of the slack or free thread is upon the opposite side of the cloth from the needle in the form of a loop, which is extended by the rotating hook. This condition of things requires the arrangement of mechanism to be modified from what is described in said Tracy's Patent No. 30,012, and the manner in which we have combined and arranged the needle and hook and bobbin and its case, with other accessory devices, to be hereinafter described, so that they will co-operate to control the proper delivery of the needle-thread and the uniform tightening of the stitches, as before described, constitutes the subject-matter of our first improvement.

Our second improvement consists in the employment, in combination with the devices which control the needle-thread in the delivering the same to the needle and the tightening of the stitch, of a device for drawing the thread from the bobbin to make the next stitch while the needle-thread is clamped or otherwise held, so that the varying resistance of the bobbin has no effect upon its delivery to the needle, and also that the thread can be freely delivered to the needle as required; and it also consists in a new combination and arrangement of the parts which form the clamping device, by which the thread is held and released at the proper

times in the operation of sewing, as before described.

Our third improvement consists in the employment, in combination with the rotating hook, of a spool-case set obliquely to the axis of the hook, each so adapted to the other in their details of construction as to co operate in the manner hereinafter described, by which a much larger spool or bobbin can be used than by the modes of construction usually adopted; and it also consists in the employment, in combination with a revolving hook and spool-case or its equivalent for carrying the lower thread, of a device which we call a "loop-check," which serves to hold the spool-case in position, to hold the loop of needle-thread below the cloth, and assist in its proper delivery to the needle, and also to hold the loop so as to enable the hook to leave it.

Our fourth improvement consists in a new mode of constructing the feeding instrument, by which a more uniform feed can be maintained with varying conditions of the work; and it also consists in a new mode of constructing the feeding-cam and the parts which co-operate with the same for the purpose of producing a variable and noiseless feed.

In the drawings, A is the frame of the machine; B, the work-plate; C, the main shaft, carrying the rotating hook D; E, the needle-arm; P, the presser-arm, and P' the presser, all, with the exception of the rotating hook D, constructed in a manner similar to what is known as the "Wheeler & Wilson sewing-machine."

F is the spool which supplies thread to the needle, arranged upon a double elliptical spring, G, which is fitted at its ends *b* and *c* to turn upon a stationary spindle, *a*, which is secured in the framing A, as shown. The needle-thread shown in red color is conveyed from the spool F through a forked arm, H, attached to and vibrating with the needle-arm, and from this arm through a spring friction-clamp, I J, attached to the needle-arm, thence through an intermittently-acting gripper, K L, also attached to the needle arm, and thence through the usual guide, *d*, at the end of the needle-arm, to the eye of the needle *n*. The part I of the friction-clamp I J and the part K of the gripper K L are portions of the same plate attached rigidly to the needle-arm. The movable portion J of the friction-clamp is placed on a small pin, *d*, and has applied to it, to produce the necessary pressure, a spring, *e*, secured to the plate I K by a screw, *e'*. The object of this friction-clamp is to keep a gentle tension on the thread between the gripper and the spool when the gripper is open. The movable portion L of the gripper constitutes a portion of a lever, L L', whose fulcrum is a knife-edge, *f*, formed on the plate K; and it is kept closed upon the thread during nearly three fourths of the revolution of the rotating hook by means of a conical volute spring, *g*, applied with its center exactly opposite to where the thread passes through the gripper; but during the re-

mainder of the revolution, commencing soon after the needle enters the cloth, the gripper is open to permit the delivery of thread to the needle.

The object of the gripper is to hold the thread positively to prevent any delivery of thread from the spool at the time of tightening each stitch. The lever L, constituting the movable jaw of the gripper, is confined to its fulcrum *f* by a slight projection, *h*, on the plate K. The said lever is acted upon to open the gripper by means of an arm, *i*, rigidly attached to the rod M', which transmits motion from the eccentric M on the main shaft to the rocker E', which carries the needle-arm, the opening being effected by the lever and arm being moved toward each other by the relative movements of the rod M' and the rocker E', and the closing being effected by the spring *g* as the movements of the said rod and rocker are continued. The forked arm H renders the operating portion of the needle-thread at all times independent of the spool F by keeping a quantity of thread greater than required for the longest stitches liberated or drawn off from the spool in advance of its being required for use, the liberation or drawing off of the thread from the spool being effected by the descent of the said forked arm as the needle-bar rises, the gripper K L having at the time a firm hold upon the thread, so that any irregularity in the friction of the spool or in the delivery of the thread, owing to entanglement or other cause, cannot affect the free delivery of the thread and the uniform tightening of the stitch. By thus keeping a portion of the thread liberated in advance, the thread is enabled to be used from a ball or skein as well as from a spool, by which means a great saving may be effected in large manufacturing operations, owing to the lower cost of the thread in balls and skeins.

The rotating hook D, of which Fig. 5 is a side view, and Fig. 6 a central section in the plane indicated by the line *x x*, Fig. 5, differs in some particulars from those heretofore used, in order to adapt it to work in combination with the spool-case N, and to so control the loop of needle-thread below the table as to assist in delivering the proper measured quantity of thread to the needle required to make each stitch, as will be hereinafter described.

The spool-case N, of which Fig. 7 is an outer face view, Fig. 8 a side view, and Fig. 9 an axial section, consists of a circular box deep enough to contain a spool, S, which is large enough to hold two hundred yards of the coarsest thread ordinarily used in sewing-machines. This case has a hinged cover or door, N', in its outer side to permit the introduction and removal of the spool, and it has a fixed central spindle, N², attached to its back for the reception of the spool, such spindle being made hollow to make the case as light as possible. *p* is the hinge of the door N', which closes with a snap. The said case is set in the hook in an oblique position, as shown in Fig. 2, such ob-

lique position being maintained by its being furnished with an oblique flange or shoulder, *m*, which extends all round, except opposite to the work-plate B, where it is omitted for a short distance, as shown at *m*², in the projection, Fig. 4, and the said flange or shoulder resting against the annular seat *m'*, provided for it in the rotating hook, the said seat being parallel with the planes of revolution of the said hook. The case is held up to the rotating hook by a guard-finger, Q, which is arranged to swing aside on a fixed pin, *g*, to permit the spool-case to be taken from or inserted in the hook, which can only be done while the tongue *k* on the case is opposite to the opening between the point and heel of the hook.

The bearing-surfaces of the finger Q consist of springs *q'* *q*², which hold the case securely against the seat in the hook in such manner as to prevent rattling, but yet permit the loops to slip freely off the outer face of the case and prevent the thread from being checked unevenly by any movement of the case from the hook. The oblique position of the case is partly to permit the needle to pass it and partly to enable the thread to be easily thrown around it, which, owing to its great thickness, would otherwise be difficult, and the prominent part that receives the loop as it is cast from the hook just as the stitch is tightened keeps the loop extended, thus preventing the thread from curling around the point of the needle in sewing thin goods. The front of the case is so cut away as to form an opening, *r* *s*. The object of so cutting it away is twofold—viz., to allow the thread to freely leave the loop-check R, which will be presently described, and to form a shoulder, *r*, against which the said check acts as a stop, to prevent the rotation of the case with the hook in the operation of the machine.

At a short distance in front of the shoulder *r* there is formed on the case a projection, *t*, to which the check serves as a stop to prevent the case from turning in the opposite direction to that above mentioned. The tongue *k*, before mentioned, having its point 12 not far from the needle, catches the thread of the loop soon after the commencement of its extension by the rotating hook, and by preventing it from being drawn round the periphery of the spool-case causes one side of it to be turned over the back of the said case. The purpose of the groove *k'* in the rotating hook is to enable the point 12 always to catch the loop of the needle-thread as it is carried forward by the rotation of the hook and prevent it from being drawn into the joint between the hook and spool-case. The locking-thread (shown in blue color) leaves the spool-case through an opening, 14, in the top, and in order to prevent its being drawn out too easily it has applied to press upon it outside of the said hole a spring, *u*, in which is a notch, 15, to guide it to the needle-hole in the work-plate.

The loop-check R is made of steel or other metal and, as before described, is stationary

in front of the shoulder *r* of the spool-case. Its upper or operating part, 13, viewed looking toward the side of the rotating hook and spool-case, as in Fig. 1, is of slightly hooked form, but so rounded as to present no angles that would hold the thread, so that it could not be drawn off by a pull in more or less upward direction after it is relieved from the hook. The said part 13, viewed from the top, as shown in Fig. 10, which is a top view of the loop-check, has an oblique surface, so that while the thread is placed across it and held partly around it, or kept stretched tightly against it, as shown in Fig. 10 by the red line, the said thread cannot be drawn from under it by an upward pull; but when the thread is not thus held closely around or across it an upward pull will draw it off easily. The lower part of the loop, in being drawn over the spool-case by an operation substantially the same as that in other rotating-hook sewing-machines, arrives at the shoulder *r* and slips off it and under the loop-check, as shown in Figs. 1 and 3, and the rotating hook has then drawn the part of the loop which passed behind the case (which I will term the "back part") to such a position that the portion of the thread under the check will have the direction shown in Fig. 10, and so be held by the check alone, and the rotating hook will continue to give this direction to the back part of the loop until the loop has been entirely thrown off it. This loop-check is secured to the framing of the machine by means of the screw *g*, on which the finger Q works, and it is grooved to fit a tongue, *q*¹, on the framing, and has a slot, *q*³, for the passage of the screw *g*, to provide for its adjustment in a direction concentric to the axis of the rotating hook and spool-case, the object of such adjustment being to bring it farther or not so far under the spool-case, to make it act earlier or later in the descent of the needle, and thus cause a greater or less quantity of the needle-thread to be taken from its spool, the said check acting in combination with the needle to effect and regulate the supply of its thread from the spool. The said check has fitted to a mortise in its point a light spring, *r'*, which projects very slightly from it, but is kept within the check by the pressure of the shoulder *r* against it in the running of the machine until the thread of the loop commences to pass between the said shoulder and the check, when it aids to press back the said shoulder far enough to let it pass, but continues to detain the thread momentarily after it has passed the solid portion of the check, and hence it makes the liberation of the thread from the check easier and more gradual. Although we have described the loop-check as arranged in combination with a spool-case, yet it may be usefully employed in machines where the spool-case is not used, as is the case in the Wheeler & Wilson machine, before referred to, in which case the position and form of the same would be altered to adapt it to the hook and bobbin used in such machines.

The combined operation of the rotating hook, spool-case, thread-controlling apparatus, and loop-check is as follows: Just as the eye of the needle is descending through the cloth, and as the loop last formed and upon the hook is approaching very near to the check, as shown in Fig. 1, the hook by its continued rotation draws the loop over the shoulder *r* and under the check *R*, which detains the loop, so that it will be tightly drawn around the hook and spool-case before the needle has completed its descent, after which the necessary amount of thread to allow the needle to complete its downward movement is drawn from the spool through the open gripper. This quantity is the amount necessary to form a perfect stitch. The check then continues to detain the loop until the latter has escaped from the point of the rotating hook and commences to be drawn up by the ascent of the needle. The tightening of the stitch is effected in the usual manner by the combined action of the continued rise of the needle-arm and the continued rotation of the hook, except in sewing thick goods, when it receives an additional strain just before the loop is turned off the point of the hook by the check. As the needle is completing its upward movement the forked arm *H* by its descent draws off thread from the spool *F*. In this action of the fork *H* its movement is sufficient to draw off more thread than is necessary to make a stitch. The quantity of thread drawn through the gripper by the needle in its descent is gaged by the thickness of the cloth and the length of feed, and as it is desirable to have the upper and lower threads interlace in the middle of the cloth the difference in the quantity required by the needle for various thickness is equal to the difference of thickness, but the action of the needle, unless it were connected by the action of the hook and check, as will be presently explained, would be to make the difference equal to twice that amount. This action is caused by the unfinished stitch and the location of the slack thread on the opposite side of the work to that from which the needle-thread is supplied, as we will now attempt to explain by the aid of Fig. 16. When the eye of the needle reaches the cloth at 30 the loop 22, below the table, will be shortened by the thickness of the cloth, as shown at 21, and when it has descended through the cloth the loop will be shortened again by the thickness of the cloth, as shown at 20. If the length of the loop below the table were the same in sewing thick as in sewing thin goods, the quantity of thread drawn from the spool would be such that the under or locking thread would be just drawn to the under side. The needle cannot commence drawing thread from the spool until it has drawn the loop below the cloth tight around the check, spool-case, and hook, on account of the friction on the thread produced by the friction-clamp *J* being greater than the friction on the thread passing through the cloth at 21. Hence by causing the length of the loop to be decreased as the cloth in-

creases in thickness the amount of the decrease will be free to be drawn up by the needle, which will correspondingly delay the commencement of drawing from the spool and the quantity taken. This is effected partly by the position of the shoulder of the hook and check at the time of commencing to draw thread from the spool and partly by the shape of the heel or tail of the hook over which the thread rests during the drawing of the thread. This is illustrated by Figs. 1, 15, both of which show the position of the parts at the time of commencing to take thread from the spool. Fig. 1 shows the positions with thick goods and Fig. 15 with thin goods. It will be seen in Fig. 15 that the rotating hook has passed much farther and the loop is much longer, its thread being in a tortuous position, the part passing over the heel resting on the fullest part *l*. In Fig. 1 the hook is much less advanced, and the thread on the heel is in the lowest part, which produces the necessary shortening of the loop for the aforesaid correction. The length of the loop may be decreased to the desired extent by cutting out the heel at *l*.

The improvement in the feeding device is best illustrated in Fig. 12, in which and in Figs. 2 and 3 *T* represents the feed-bar, applied under the work-plate in the manner common to what is known as the "four-motion" feed, and having the toothed dog *U* connected with it by a spring, *V*, to permit the upward and downward movement to bite and release the cloth; but the dog, instead of being rigidly attached to the spring, as is usually the case, is arranged to rock, so as to adapt itself to any increase or diminution of thickness of the work, either sudden or gradual. The said dog is made of a separate piece of steel, with a curved or rounded bottom, and a conical cavity in the said bottom for the reception of the pointed end of an adjusting-screw, *w*, screwed through a block of metal, *V'*, which is riveted or otherwise secured to the spring *V*. Portions 18 18 of the spring are extended beyond its connection with the said block to press upon the flat upper surfaces of shoulders *y y*, provided on the sides of the dog near the middle of its length, and so keep the dog on the point of the screw, on which it is free to rock to accommodate itself to the varying thickness of the work. The vertical movement of the feeding-bar *V*, to cause the dog *U* to engage with the cloth, is imparted by an incline on the periphery of the cam *W* acting against the bottom of the block *V'*, and the longitudinal movement of the bar is produced by the broad inclined face of the same piece acting against the contact-surface *y* upon the lever *Y*, (shown partly in dotted lines in Fig. 3,) which lever acts against the projection *V²* upon the feed-bar, and throws it forward in the direction that the teeth of the feed-dog *U* are inclined. The movement of the system in the opposite direction is produced by the spring *T'*. The face of the cam *W*, which acts upon

the lever Y, is made with the incline at the periphery of sufficient elevation to give the feeding-dog an extent of motion in the direction of the seam sufficient for the longest stitch required to be made, and at the other part next to the shaft of an elevation sufficient to make the shortest stitch desired to be made, and the surface in a radial direction inclined from one to the other.

The lever Y is mounted upon an axis, Z, which is made to slide longitudinally in bearings in the frame A, transversely to the shaft C, so as to present the contact-surface y to that part of the cam W which will impart just the extent of motion to the feed-dog U that will give the desired length to the stitches. The advantage in employing such a cam to actuate the feed-bar is that the contact-surface y of the lever Y bears constantly upon it, whatever may be the length of stitch to be made, so that the movements of the feeding mechanism are noiseless and without abruptness in any part, however fast the machine may be run.

Having thus described our invention, we desire to be understood that we do not claim broadly the delivery to the needle of the exact length of thread required to make each stitch before the stitch is made, and then drawing up the thread by a positive action to complete the stitch, as that has already been done in the machine patented to Dwight Tracy, No. 30,012, before mentioned; but

What we do claim is as follows, namely:

1. In a sewing-machine which forms the stitches by means of a needle and rotating hook, as described, the delivering to the needle at each stitch a measured length of the needle-thread corresponding to the thickness of material to be sewed and the length of the stitches to be made, and the drawing up of such measured length of thread by a uniform and positive action to complete the stitch by means of the needle and its actuating mech-

anism, and the gripper for holding and controlling the needle-thread above the cloth, and the rotating hook and loop-check for holding and distending the loop of needle-thread below the cloth, or other devices equivalent thereto, so combined and arranged as to co-operate substantially in the manner herein described.

2. The employment, in combination with the devices which control the needle-thread in delivering the same to the needle and tightening the stitch, of a device for drawing sufficient thread from the bobbin to make the next stitch in advance of its delivery to the needle, substantially in the manner and for the purpose described.

3. Forming the clamping device or gripper for the needle-thread by a combination of the bent lever L' with the plate K on the needle-arm, or their equivalents, and operated by the stop i on the connecting-rod M', substantially as described.

4. The employment, in combination with the rotating hook, of a spool-case placed diagonally to the axis of motion of the hook, and held in position by any appropriate devices to enable a large bobbin to be used and the loop of needle-thread to be passed around it more readily, substantially as described.

5. The employment, in combination with a needle and rotating hook for manipulating the needle-thread, of the "loop-check," so called, constructed and operating substantially as described.

6. The employment of a detached or movable feed-dog, as described, in combination with the feeding mechanism, substantially as described.

Boston, August 16, 1862.

DWIGHT TRACY.
GEO. HOBBS.

Witnesses:

HENRY CHAPIN,
O. F. HARRIS.