



US00RE44925E

(19) **United States**
(12) **Reissued Patent**
Vincent

(10) **Patent Number:** **US RE44,925 E**
(45) **Date of Reissued Patent:** ***Jun. 3, 2014**

(54) **SPATIAL REFERENCED PHOTOGRAPHIC SYSTEM WITH NAVIGATION ARRANGEMENT**

(56) **References Cited**

U.S. PATENT DOCUMENTS

(75) Inventor: **Robert S. Vincent**, Wakefield, MA (US)

3,363,332 A 1/1968 Wilson et al.

3,580,996 A 5/1971 Maxey

(73) Assignee: **Transcenic, Inc.**, Lake Charles, LA (US)

(Continued)

(*) Notice: This patent is subject to a terminal disclaimer.

FOREIGN PATENT DOCUMENTS

(21) Appl. No.: **13/084,087**

CA 2058877 8/1992

JP 63164782 7/1988

(22) Filed: **Apr. 11, 2011**

(Continued)

Related U.S. Patent Documents

OTHER PUBLICATIONS

Reissue of:

(64) Patent No.: **7,050,102**
Issued: **May 23, 2006**
Appl. No.: **09/723,767**
Filed: **Nov. 28, 2000**

Vu, Ngoc-Yen; PCT Search Report, dated May 15, 1996, PCT No. PCT/US96/01434; 1 page.

(Continued)

U.S. Applications:

Primary Examiner — Twyler Haskins

Assistant Examiner — Carramah J Quiett

(63) Continuation of application No. 12/126,664, filed on May 23, 2008, now Pat. No. Re. 42,289, which is an application for the reissue of Pat. No. 7,050,102, which is a continuation of application No. 08/894,206, filed as application No. PCT/US96/01434 on Jan. 31, 1996, now Pat. No. 6,195,122, which is a continuation-in-part of application No. 08/383,471, filed on Jan. 31, 1995.

(74) *Attorney, Agent, or Firm* — Fitch, Even, Tabin & Flannery, LLP

(51) **Int. Cl.**
H04N 5/222 (2006.01)
H04N 5/232 (2006.01)
H04N 5/77 (2006.01)
H04N 5/228 (2006.01)

(57) **ABSTRACT**

An image system which captures, along with the images, information defining both the position and the orientation of the camera along with the distance to the subject. A video camera is attached to three accelerometers, two gyroscopes, and a rangefinder. Data gathered from these devices and defining the pitch, yaw, and roll of the camera, the camera's acceleration, and the distance to the subject is captured and recorded along with video images. The video images are later stored within a computer's data base along with data defining the position and orientation of the camera and the distance to the subject for each image, this latter data being computed from the captured data. The images may then be presented to the user in a three-dimensional display in which the user can navigate through the images using a joystick device, with the images located in positions corresponding to the positions in space of the objects that were imaged.

(52) **U.S. Cl.**
CPC **H04N 5/23293** (2013.01); **H04N 5/772** (2013.01); **H04N 5/232** (2013.01)
USPC ... **348/333.02**; 348/141; 348/143; 348/208.2; 348/208.14

(58) **Field of Classification Search**
USPC 348/135, 141-143, 207.99, 207.1, 348/208.2, 208.12, 208.14, 222, 373-375
See application file for complete search history.

12 Claims, 30 Drawing Sheets

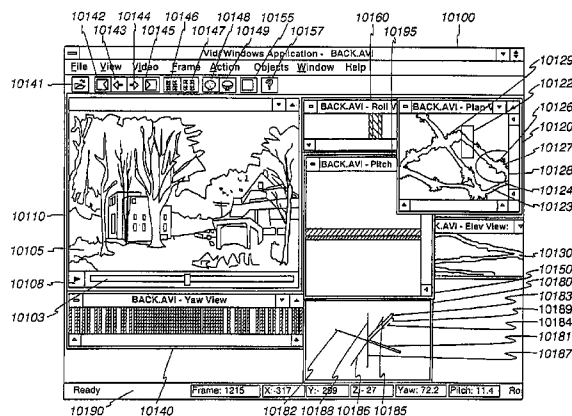

(56)

References Cited

U.S. PATENT DOCUMENTS

4,023,202 A	5/1977	Louie et al.	5,335,072 A	8/1994	Tanaka et al.
4,084,184 A	4/1978	Crain	5,381,338 A	1/1995	Wysocki et al.
4,169,666 A	10/1979	Slater et al.	5,384,588 A	1/1995	Martin et al.
4,179,823 A	12/1979	Sullivan et al.	5,388,990 A	2/1995	Beckman
4,283,766 A	8/1981	Snyder et al.	5,392,225 A	2/1995	Ward
4,343,037 A	8/1982	Bolton	5,396,583 A	3/1995	Chen et al.
4,373,169 A	2/1983	Burkam	5,490,075 A	2/1996	Howard et al.
4,449,198 A	5/1984	Kroon et al.	5,495,576 A	2/1996	Ritchey
4,463,380 A	7/1984	Hooks, Jr.	5,512,941 A	4/1996	Takahashi et al.
4,484,192 A	11/1984	Seitz et al.	5,523,783 A	6/1996	Cho
4,486,775 A	12/1984	Catlow	5,530,650 A	6/1996	Biferno et al.
4,488,249 A	12/1984	Baker	5,555,018 A	9/1996	Von Braun
4,495,580 A	1/1985	Keeearn	5,559,707 A	9/1996	DeLorme et al.
4,561,063 A	12/1985	Craig et al.	5,563,650 A	10/1996	Poelstra
4,628,453 A	12/1986	Kamejima et al.	5,568,152 A	10/1996	Janky et al.
4,645,459 A	2/1987	Graf et al.	5,598,209 A *	1/1997	Cortjens et al. 348/211.12
4,682,160 A	7/1987	Beckwith, Jr. et al.	5,600,368 A	2/1997	Matthews
4,687,326 A	8/1987	Corby, Jr.	5,601,353 A	2/1997	Naimark et al.
4,737,921 A	4/1988	Goldwasser et al.	5,602,564 A *	2/1997	Iwamura et al. 715/782
4,751,507 A	6/1988	Hama et al.	5,633,946 A	5/1997	Lachinski et al.
4,752,836 A	6/1988	Blanton et al.	5,636,036 A	6/1997	Ashbey
4,766,541 A	8/1988	Bleich et al.	5,642,285 A	6/1997	Woo et al.
4,791,572 A	12/1988	Green, III et al.	5,644,694 A	7/1997	Appleton
4,807,158 A	2/1989	Blanton et al.	5,645,077 A	7/1997	Foxlin
4,829,304 A	5/1989	Baird	5,682,332 A	10/1997	Ellenby et al.
4,855,820 A	8/1989	Barbour	5,684,943 A	11/1997	Abraham et al.
4,855,822 A	8/1989	Narendra et al.	5,689,611 A	11/1997	Ohta et al.
4,857,902 A	8/1989	Naimark et al.	5,703,604 A	12/1997	McCutchen
4,876,651 A	10/1989	Dawson et al.	5,729,471 A	3/1998	Jain et al.
4,891,761 A	1/1990	Gray et al.	5,739,848 A	4/1998	Shimoura et al.
4,910,674 A	3/1990	Lerche	5,751,578 A	5/1998	Quinn et al.
4,939,662 A	7/1990	Nimura	5,764,276 A	6/1998	Martin et al.
4,939,663 A	7/1990	Baird	5,768,640 A	6/1998	Takahashi et al.
4,969,036 A	11/1990	Bhanu et al.	5,793,367 A	8/1998	Taguchi
4,972,319 A	11/1990	Delorme	5,794,216 A	8/1998	Brown
4,984,179 A	1/1991	Waldern	5,815,411 A	9/1998	Ellenby et al.
4,989,151 A	1/1991	Nuimura	5,838,906 A *	11/1998	Doyle et al. 715/205
4,992,866 A	2/1991	Morgan	5,850,352 A	12/1998	Moezzi et al.
4,994,971 A	2/1991	Poelstra	5,854,843 A	12/1998	Jacknin et al.
5,016,007 A	5/1991	Iihoshi et al.	5,881,321 A	3/1999	Kivolowitz
5,023,725 A	6/1991	McCutchen	5,897,223 A	4/1999	Tritchew et al.
5,023,798 A	6/1991	Neukirchner et al.	5,913,078 A	6/1999	Kimura et al.
5,049,988 A	9/1991	Sefton et al.	5,937,096 A	8/1999	Kawai
5,060,162 A	10/1991	Ueyama et al.	6,006,126 A	12/1999	Cosman
5,072,396 A	12/1991	Fitzpatrick et al.	6,011,585 A	1/2000	Anderson
5,073,819 A	12/1991	Gates et al.	6,037,936 A	3/2000	Ellenby et al.
5,075,861 A	12/1991	Hasson et al.	6,040,824 A *	3/2000	Maekawa et al. 345/173
5,086,396 A	2/1992	Waruszewski et al.	6,064,355 A	5/2000	Donahue
5,089,816 A	2/1992	Holmes, Jr.	6,133,947 A	10/2000	Mikuni
5,115,398 A	5/1992	De Jong	6,141,034 A	10/2000	McCutchen
5,123,088 A	6/1992	Kasahara et al.	6,195,122 B1	2/2001	Vincent
5,124,938 A	6/1992	Algrain	6,233,004 B1	5/2001	Tanaka et al.
5,128,874 A	7/1992	Bhanu et al.	6,282,362 B1	8/2001	Murphy et al.
5,133,050 A	7/1992	George et al.	6,292,215 B1	9/2001	Vincent
5,146,212 A	9/1992	Venolia	6,449,011 B1	9/2002	Muramatsu et al.
5,155,683 A	10/1992	Rahim	6,680,746 B2	1/2004	Kawai et al.
5,166,878 A	11/1992	Poelstra	6,768,563 B1	7/2004	Murata et al.
5,177,685 A	1/1993	Davis et al.	7,050,102 B1	5/2006	Vincent
5,182,641 A	1/1993	Diner et al.	7,849,393 B1	12/2010	Henricks et al.
5,187,571 A	2/1993	Braun et al.	RE42,289 E	4/2011	Vincent
5,189,402 A	2/1993	Naimark et al.	2001/0026318 A1	10/2001	Yonezawa et al.
5,214,615 A	5/1993	Bauer	2002/0067412 A1	6/2002	Kawai
5,214,757 A	5/1993	Mauney et al.	2010/0250120 A1	9/2010	Waupotitsch et al.
5,227,985 A	7/1993	DeMenthon	2010/0302280 A1	12/2010	Szeliski et al.
5,259,037 A	11/1993	Plunk	2010/0325589 A1	12/2010	Ofek et al.
5,262,867 A	11/1993	Kojima			
5,265,025 A	11/1993	Hirata			
5,267,042 A	11/1993	Tsuchiya et al.			
5,268,998 A	12/1993	Simpson			
5,270,694 A	12/1993	Naimark et al.			
5,274,387 A	12/1993	Kakihara et al.			
5,299,300 A	3/1994	Femal et al.			
5,322,441 A	6/1994	Lewis et al.			
5,325,472 A	6/1994	Horiuchi et al.			
5,327,233 A	7/1994	Choi			

FOREIGN PATENT DOCUMENTS

JP	03072309	3/1991
JP	4336091	11/1992
JP	5048964	2/1993
JP	2004173083	6/2004
WO	9016131	12/1990
WO	9300647	1/1993

OTHER PUBLICATIONS

Vu, N.; PCT Examination Report, dated Mar. 10, 1997; PCT No. PCT/US96/01434; 6 pages.

(56)

References Cited

OTHER PUBLICATIONS

- Non-Final Office Action dated Apr. 14, 2010; U.S. Appl. No. 12/126,664; 20 pages.
- Radatz, J.; "gimbal", The IEEE Standard Dictionary of Electrical and Electronic Terms; 1997, New York, NY; IEEE Standards Office, Sixth Edition, p. 454.
- Mohl, R.; "Development and Implementation of the Movie Map," Chapters 3-6, pp. 87-227. 1981.
- Fisher, S.S. et al.; "Virtual Environment Display System", Interactive 3D Graphics, Oct. 23-24, pp. 77-87, 1986.
- Fisher, S. S.; "Viewpoint Dependent Imaging: An Interactive Stereoscopic Display"; Department of Architecture; Oct. 8, 1981. pp. 1-77.
- Mohl, R.; "Development and Implementation of the Movie Map," Chapters 1 and 2 (pp. 1 to 86, particularly the overview description presented on p. 9 and the system configuration description presented on pp. 56-81) of "Cognitive space in the interactive movie map: an investigation of spatial learning in virtual environments." M.I.T. Ph. D. Thesis (Dept. of Architecture, MA Institute of Technology, Cambridge, MA, 1982). (Downloadable from MIT Libraries DSpace Citable URI: <http://hdl.handle.net/1721.1/15702>).
- Wilson, K.S., "The Palenque Optical Disc Prototype: Design of Multimedia Experiences for Education and Entertainment in a Nontraditional Learning Context. Technical Report No. 44", Center for Children and Technology, Bank Street College of Education, May 1987, pp. 1-15, 19 pages.
- Ackermann, F., "On the Status and Accuracy Performance of GPS Photogrammetry", University of Stuttgart, Institute for Photogrammetry, 1994, pp. 80-90, Stuttgart, Germany, 11 pages.
- Arons, B., "Mit's Sampler Disc of Disc Techniques", Educational and Industrial Television, Jun. 1984, pp. 36-40, vol. 16, No. 6, 4 pages.
- Aukstakalnis, S. et. al., "Silicon Mirage: The Art and Science of Virtual Reality", 1992, Part III, pp. 183-208, Peachpit Press, Inc., Berkeley, United States of America, 33 pages.
- Bao-Zong, Y. et. al., "Tutorial: Computer Vision-Towards a Three-Dimensional World", Engineering Applications of Artificial Intelligence, Jun. 1989, pp. 94-108, vol. 2, 15 pages.
- Blinn, J., "Where Am I? What Am I Looking At?", Jim Blinn's Corner, IEEE Computer Graphics and Applications, Jul. 1988, pp. 76-81, 6 pages.
- Bove, Jr., V.M., "Pictorial Applications for Range Sensing Cameras", SPIE Image Processing, Analysis, Measurement, and Quality, 1988, pp. 10-17, vol. 901, 8 pages.
- Brooks, Jr., F.P., "Grasping Reality Through Illusion: Interactive Graphics Serving Science", University of North Carolina, Department of Computer Science, Mar. 1988, pp. 1-13, Chapel Hill, United States of America, 15 pages.
- Brooks, T. L. et. al., "Operator Vision Aids for Telerobotic Assembly and Servicing in Space", Proceedings of the 1992 IEEE International Conference on Robotics and Automation, May 1992, pp. 886-891, Nice, France, 6 pages.
- Stoker, C.R. et al, "Antarctic Undersea Exploration Using a Robotic Submarine with a Telepresence User Interface", Environmental Applications of AI, IEEE Expert, Dec. 1995, pp. 14-23, 10 pages.
- Teodosio, L. A. and Mills, M., "Panoramic Overviews for Navigating Real-World Scenes", Massachusetts Institute of Technology and Apple Computer, 1993, 6 pages.
- Dixon, D., "DVI Pilot Applications", Manifest Technology: Making Sense of Digital Media Technology, Copyright 1999-2012, 5 pages.
- Drucker, S. M. et. al., "Intelligent Camera Control in a Virtual Environment", Proceedings of Graphics Interface '94, 1994, pp. 190-199, 10 pages.
- Drucker, S. M., "Intelligent Camera Control for Graphical Environments", Program in Media Arts and Sciences, School of Architecture and Planning, Massachusetts Institute of Technology, Jun. 1994, pp. 1-207, Cambridge, United States of America, 207 pages.
- El-Sheimy, N. et. al., "Kinematic Positioning in Three Dimensions Using CCD Technology", Vehicle Navigation and Information Systems Conference, 1993, pp. 472-475, Ottawa, Canada, 4 pages.
- El-Sheimy, N., "A GPS/INS Aided Video Camera System for Rapid GIS Surveys in Urban Centers", 7th International Technical Meeting of the Satellite Division of the Institute of Navigation, Sep. 1994, pp. 1357-1366, Salt Lake City, United States of America, 11 pages.
- Fisher, S.S., "Viewpoint Dependent Imaging: An Interactive Stereoscopic Display", Massachusetts Institute of Technology, 1982, pp. 1-77, 77 pages.
- Fitzmaurice, G.W., et al., "Virtual Reality for Palmtop Computers", ACM Transactions on Information Systems, Jul. 1993, pp. 197-218, vol. 11, No. 3, 22 pages.
- Fuller, B. B. et. al., "An Overview of the Magic Project", The MITRE Corporation, Dec. 1993, pp. 1-8, 14 pages.
- Glenn, S., "Real Fun, Virtually: Virtual Experience Amusements and Products in Public Space Entertainment", SimGraphics Engineering Corporation, 1992, pp. 77-83, South Pasadena, United States of America, 7 pages.
- Habfeld, S. et. al., "Intraoperative Navigation in Oral and Maxillofacial Surgery", International Journal of Oral and Maxillofacial Surgery, 1995, pp. 111-119, vol. 24, Denmark, 9 pages.
- Hine III, B.P., et. al., "The Application of Telepresence and Virtual Reality to Subsea Exploration", The 2nd Workshop on Mobile Robots for Subsea Environments, Proc. ROV'94, May 1994, 11 pages.
- Hitchner, L. E., "The NASA Ames Virtual Planetary Exploration Testbed", Wescon Conference Record, Nov. 1992, pp. 1-6, Anaheim, United States of America, 6 pages.
- Hitchner, L. E., "Virtual Planetary Exploration: A Very Large Virtual Environment", Tutorial on Implementing Immersive Virtual Environments, 1992, pp. 6.1-6.16, 16 pages.
- Holloway, R. et. al., "Virtual-Worlds Research at the University of North Carolina at Chapel Hill", Proceedings of Computer Graphics '91, Nov. 1991, pp. 181-196, London, England, 15 pages.
- Ince, I. et. al., "Virtuality and Reality: A Video/Graphics Environment for Teleoperation", STX Robotics, 1991, pp. 1083-1089, 7 pages.
- Iwata, H., "Force Display for Virtual Worlds", Institute of Engineering Mechanics, University of Tsukuba, 1992, pp. 111-116, Tsukuba, Japan, 6 pages.
- Laurel, B. et. al., "Interface and New Interactive Systems", 1990, pp. 2-1 to 2-13, Transcript, 13 pages.
- Leclerc, Y. G. et. al., "TerraVision: A Terrain Visualization System", AI Center, SRI International, Apr. 22, 1994, pp. 1-20, 20 pages.
- Lippman, A., "Movie-Maps: An Application of the Optical Videodisc to Computer Graphics", Architecture Machine Group, Massachusetts Institute of Technology, 1980, pp. 32-42, Cambridge, United States of America, 11 pages.
- McKeown, Jr., D.M. et al., "Research in Automated Analysis of Remotely Sensed Imagery", Image Understanding Workshop: Proceedings of a Workshop held in Washington, D.C., Apr. 1993, pp. 231-251, Morgan Kaufmann Publishers, Inc., San Mateo, United States of America, 30 pages.
- Miller, G. et. al., "The Virtual Museum: Interactive 3D Navigation of a Multimedia Database", The Journal of Visualization and Computer Animation, 1992, pp. 183-197, vol. 3, No. 3, 16 pages.
- Mohl, R., "Cognitive Space in the Interactive Movie Map: An Investigation of Spatial Learning in Virtual Environments", Department of Architecture, Massachusetts Institute of Technology, 1981, pp. 1-226, 232 pages.
- Naimark, M., "Elements of Realspace Imaging: A Proposed Taxonomy", Electronic Imaging Proceeding, 1991, pp. 1-10, vol. 1457, San Jose, United States of America, 10 pages.
- Naimark, M., "Magic Windows, Magic Glasses, and Magic Doors: Experiencing Place via Media", Artshow catalog, Kanagawa International Art and Science Exhibition, Oct. 1989, pp. 1-2, Kanagawa, Japan, 2 pages.
- Naimark, M., "Moviemap Basics", MultiMediale 2 catalog, Zentrum fur Kunst und Medientechnologie, 1991, p. 2, Karlsruhe, Germany, 1 page.
- Naimark, M., "Spatial Correspondence in Motion Picture Display", Optics in Entertainment II, 1984, pp. 78-81, vol. 462, 4 pages.
- Naimark, M., "The Optical Videodisc and New Media Forms", Video 80, San Fransisco International Film Festival, 1982, pp. 24-25, 2 pages.

(56)

References Cited

OTHER PUBLICATIONS

- Naimark, M., "VBK—A Moviemap of Karlsruhe' Mediated Reality and the Consciousness of Place", *Tomorrow's Realities* catalog, *Signograph*, 1991, p. 2, Las Vegas, United States of America, 1 page.
- Negroponte, N., "The Impact of Optical Videodiscs on Filmmaking", *Massachusetts Institute of Technology*, Jun. 1979, pp. 1-29, 32 pages.
- Nitao, J. J., et. al., "Computer Modelling: A Structured Light Vision System for a Mars Rover", *SPIE—The International Society for Optical Engineering, Proceedings: Mobile Robots IV*, Nov. 1989, pp. 168-177, vol. 1195, Philadelphia, United States of America, 11 pages.
- Novak, K., "Application of Digital Cameras and GPS for Aerial Photogrammetric Mapping", *Department of Geodetic Science and Surveying, Center for Mapping, The Ohio State University*, 1992, pp. 5-9, 5 pages.
- Pausch, R., "Virtual Reality on Five Dollars a Day", *ACM*, 1991, pp. 265-270, 6 pages.
- Ripley, G.D., "DVI—A Digital Multimedia Technology", *Journal of Computing in Higher Education*, 1990, pp. 74-103, vol. I (2), 30 pages.
- Schwarz, K. P. et. al., "VIASAT—A Mobile Highway Survey System of High Accuracy", *IEE Vehicle Navigation and Information Systems Conference*, 1993, pp. 476-481, Ottawa, Canada, 6 pages.
- Sequeira, V. et. al., "3D Environment Modelling Using Laser Range Sensing", *Robotics and Autonomous Systems*, 1995, pp. 81-91, vol. 16, 11 pages.
- Shiffer, M. J., "A Geographically-Based Multimedia Approach to City Planning", *ACM, CHI94 Conference Companion*, 1994, pp. 265-266, Boston, United States of America, 2 pages.
- Shiffer, M. J., "A Hypermedia Implementation of a Collaborative Planning System", *University of Illinois at Urbana-Champaign*, 1992, pp. 1-188, Urbana, United States of America, 202 pages.
- Defendants' Supplemental Response to Plaintiff's First Set of Interrogatories (No. 6), dated Feb. 29, 2012; 19 pgs.
- Defendants' Supplemental Response to Plaintiff's First Set of Interrogatories (No. 6), dated Feb. 29, 2012; Exhibit A; 10 pgs.
- Teodosio, L. A., "Salient Stills", *Media Arts and Science Section, School of Architecture and Planning, Massachusetts Institute of Technology*, Jun. 1992, pp. 1-71, Cambridge, United States of America, 71 pages.
- Thorman, C.P., "Using Video as Textural Input to a Computer Graphic Database", *Massachusetts Institute of Technology*, Dec. 1988, pp. 1-20, 25 pages.
- Vanderburgh, J.C., "Space Modeler: An Expanded, Distributed, Virtual Environment for Space Visualization", *Air Force Institute of Technology*, Dec. 1994, pp. 1-79, 93 pages.
- Ware, C. et. al., "Exploration and Virtual Camera Control in Virtual Three Dimensional Environments", *ACM*, 1990, pp. 175-183, 9 pages.
- Wilson, K. G., "Synthetic BattleBridge: Information Visualization and User Interface Design Applications in a Large Virtual Reality Environment", *Air Force Institute of Technology*, Dec. 1993, pp. 1-85, 95 pages.
- Wilson, K. S. et. al., "The Palenque Project: A Process of Design and Development as Research in the Evolution of an Optical Disc Prototype for Children. Technical Report No. 47", *Center for Children and Technology, Bank Street College of Education*, Dec. 1987, pp. 1-12, 15 pages.
- Wilson, K. S., "Palenque: An Interactive Multimedia Digital Video Interactive Prototype for Children", *Center for Children and Technology, Bank Street College of Education*, 1988, pp. 275-279, 5 pages.
- Wilson, K. S., "The Palenque Optical Disc Prototype: The Design of a Multimedia Discovery Based Experience for Children", *Children's Environments Quarterly*, 1988, pp. 7-13, vol. 5, No. 4, 7 pages.
- Wu, S. S. C., et. al., "Photogrammetric Application of Viking Orbital Photography", *Planet Space Sci.*, 1982, pp. 45-55, vol. 30, No. 1, Pergamon Press Ltd., Great Britain, 10 pages.
- Young, D., *Inventing Interactive*, <http://www.inventinginteractive.com/2010/03/18/a5pen-movie-map/>. Printed on Oct. 25, 1992, 77 pages.
- Zhou, Q. et. al., "Development of a Multimedia Spatial Information System", *Invited and Presented Papers of the XVIIth Congress, Technical Commission II, Systems for Data Processing and Analysis*, Aug. 1992, pp. 67-71, United States of America, 6 pages.
- Defendants' Supplemental Response to Plaintiff's First Set of Interrogatories (No. 6), dated Feb. 29, 2012; Exhibit B-1; 60 pgs.
- Defendants' Supplemental Response to Plaintiff's First Set of Interrogatories (No. 6), dated Feb. 29, 2012; Exhibit B-2; 83 pgs.
- Defendants' Supplemental Response to Plaintiff's First Set of Interrogatories (No. 6), dated Feb. 29, 2012; Exhibit B-3; 103 pgs.
- Defendants' Supplemental Response to Plaintiff's First Set of Interrogatories (No. 6), dated Feb. 29, 2012; Exhibit B-4; 83 pgs.
- Defendants' Supplemental Response to Plaintiff's First Set of Interrogatories (No. 6), dated Feb. 29, 2012; Exhibit B-5; 68 pgs.
- Defendants' Supplemental Response to Plaintiff's First Set of Interrogatories (No. 6), dated Feb. 29, 2012; Exhibit B-6; 83 pgs.
- Defendants' Supplemental Response to Plaintiff's First Set of Interrogatories (No. 6), dated Feb. 29, 2012; Exhibit B-7; 54 pgs.
- Defendants' Supplemental Response to Plaintiff's First Set of Interrogatories (No. 6), dated Feb. 29, 2012; Exhibit B-8; 65 pgs.
- Defendants' Supplemental Response to Plaintiff's First Set of Interrogatories (No. 6), dated Feb. 29, 2012; Exhibit B-9; 83 pgs.
- Microsoft Corporation's Answer and Counterclaims to Transcenic, Inc.'s First Amended Complaint for Patent Infringement; filed Sep. 12, 2011; 11 pgs.
- Mapquest, Inc. and AOL Inc.'s Answer, Defenses, and Counterclaims to Transcenic, Inc.'s Complaint for Infringement; filed Sep. 12, 2011; 12 pgs.
- Complaint for Patent Infringement; filed Jul. 1, 2011; 97 pgs.
- Defendant Goggle Inc.'s Answer and Counterclaims to Transcenic, Inc.'s First Amended Complaint for Patent Infringement; filed Sep. 12, 2011; 13 pgs.
- First Amended Complaint for Patent Infringement; filed Aug. 24, 2011; 99 pgs.
- Notice of Service for Defendant's Supplemental Response to Plaintiff's First Set of Interrogatories (No. 6) dated Feb. 29, 2011; 3 pgs.
- Aspen Interactive Movie Map from 222.youtube.com/watch?v=Hf6LkqgXPMUmeature=related; DEF0005847.
- Aspen Movie Map from www.youtube.com/watch?v=w18MyqszIYc; DEF0005848.
- Bank Street College of Education; Palenque Color Slides; DEF0005766-DEF0005835.
- Bank Street College; "Palenque Project—PANS"; Oct. 6, 1986; DEF0005143-DEF0005146.
- Beers, B.J.; "Frank 2: System for Photographical Registration for Analogue Picture Presentation and Map Making. Second Phase of Examination"; Jan. 1985; DEF0005851-DEF0005883.
- Beers, B.J.; "Frank—the design of a new land surveying system using panoramic images"; 1985; DEF0005884-DEF0006042.
- Bogaerts, J.M.; Frank: System for Photographical Registration for Analogue Picture Presentation and Map Making; Mar. 1982; DEF0006296-DEF0006362.
- Brock, B.; "Computers in the Classroom, Palenque Model is an Innovative Videodisc Project, Developed by the Bank Street College in New York, has Added an Adventurous Edge to Learning"; Oct. 6, 1987; DEF0005139-0005142.
- Carson, K. M.; "A Color Spatial Display Based on a Raster Framebuffer and Varifocal Mirror"; Feb. 1985; DEF0005034-DEF0005104.
- Charnley, D. et al.; "Surface Reconstruction from Outdoor Image Sequences"; 1988, DEF0005357-DEF0005362.
- Computer World, Magasin; 1987; DEF0004251-DEF0004260.
- Defendants' Fourth Supplemental Response to Plaintiff's First Set of Interrogatories (No. 6); dated Jul. 13, 2012; 72 pgs.
- Defendants' Second Supplemental Response to Interrogatory No. 6; Exhibit A; dated Jun. 29, 2012; 20 pgs.
- Defendants' Second Supplemental Response to Interrogatory No. 6; Exhibit B-10; dated Jun. 29, 2012; 58 pgs.
- Defendants' Second Supplemental Response to Interrogatory No. 6; Exhibit B-11; dated Jun. 29, 2012; 32 pgs.

(56)

References Cited

OTHER PUBLICATIONS

- Defendants' Second Supplemental Response to Interrogatory No. 6; Exhibit B-12; dated Jun. 29, 2012; 31 pgs.
- Defendants' Second Supplemental Response to Plaintiff's First Set of Interrogatories (No. 6); dated Jun. 29, 2012; 36 pgs.
- Defendants' Third Supplemental Response to Interrogatory No. 6; Exhibit B-13; dated Jul. 6, 2012; 67 pgs.
- Defendants' Third Supplemental Response to Interrogatory No. 6; Exhibit B-14; dated Jul. 6, 2012; 64 pgs.
- Defendants' Third Supplemental Response to Plaintiff's First Set of Interrogatories (No. 6); dated Jul. 6, 2012; 52 pgs.
- D'Ignazio, F.; "d'iversions. An Electronic Field Trip"; *Compute!'s Gazette*, d'iversion, Murder at Palenque; Sep. 1988; DEF0004261-DEF0004262.
- Discursions Architecture Machine Group—Video; DEF0005846.
- Dixon, D.F., et al.; *Computer Graphics World*; "DVI Video/Graphics"; Jul. 1987; DEF0004263-DEF0004266.
- Friedman, Gary L.; "The Trustworthy Digital Camera: Restoring Credibility to the Photographic Image"; Dec. 1992 to Nov. 1994, DEF0005371-DEF0005377.
- Haas, V.; "Frank-Enkele aspecten van de verwerking van waarnemingen gedaan met het uitwekingsinstrument; de meetmethodiek, instrumentele fouten en voorverwerking van de waarnemingen"; 1988; DEF0006043-DEF0006181.
- Halfhill, T.R.; "Byte Magazine, See You Around"; May 1995; DEF0006823-DEF0006830.
- Hanson, et al.; "Overview of the SRI Cartographic Modeling Environment"; Jan. 1992; DEF0006888-DEF0006904.
- Harvard Gazette; "Multi-Media Computer Project Offers a Trip to Mayan Ruins"; Apr. 29, 1988; DEF0004292-DEF0004293.
- Information Zooms, pp. 57-66; DEF0005836-DEF0005845.
- Instructor, Special High-Tech Issue; 1987; DEF0004383-DEF0004419; 37 pgs.
- Interactive Media Manifestatie-International Conference Eindhoven, The Netherlands; Jun. 1987; DEF0004420-DEF0004426.
- Kunkel, P.; "Hyper Media"; Mar./Apr. 1989; DEF0004791-DEF0004793.
- LaserActive '87 Applications and Innovations; Sep. 29 to Oct. 2, 1987; DEF0004794-DEF0004826.
- Les Chemins Du Virtuel-Simulation infomatique et creation industrielle; 1989; DEF0004827-DEF0005018.
- Loveria, G., et al.; "MultiMedia: DVI Arrives"; Fall, 1990; DEF0005019-DEF0005022.
- Luther, A.C.; "IEEE Spectrum-DVI: how it works, You are there and in control"; pp. 45-50; Sep. 1988; DEF0005236-DEF0005254; 119 pgs.
- Manes, S.; "The Road to Respect"; Mar. 1989; DEF0005023-DEF0005033.
- McMillian, L., et al.; "Plenoptic Modeling: An Image-Based Rendering System, Department of Computer Science University of North Carolina at Chapel Hill"; Aug. 1995; DEF0005169-DEF0005176.
- Montgomery, H.; "Task Force Differential, In-Flight Differential, and Video Van Mapping"; Feb. 1994; DEF0006498-DEF0006502.
- Naimark, M.; "VBK—A Moviemap of Karlsruhe" Mediated Reality and the Consciousness of Place; Tomorrow's Realities catalog, Siggraph '91, Las Vegas; DEF0005105-DEF0005107.
- National Association of Home Builders; "Virtual Reality, Masco Corporation's Walk-through Software"; May 1996, DEF0005626-DEF0005631.
- National Convention Center, Boston, MA, Jun. 20-22, 1989; "National Educational Computing Conference—Final Program"; DEF0005108-DEF0005128.
- Palenque Handwritten Notes; DEF0004267-DEF0004291.
- Palenque Log Sheet—Team II; dated Apr. 7, 1986; DEF0005129-DEF0005138.
- Palenque Photographs; DEF0005759-DEF0005760.
- Palenque Photographs; DEF0005761-DEF0005762.
- Palenque Photographs; DEF0005763-DEF0005765.
- Palenque Route Numbers; DEF0005187-DEF0005198.
- Palenque: Optical Disc Prototype Video; DEF0005849.
- Perry, T.S.; *Science Observer—A New World of Viewer-Controlled Video*; Mar. 1989; DEF0005199-DEF0005201.
- Blaho, G.; *Field Experiences with Fully Digital Mobile Stereo Image Acquisition System*; May 24-26, 1995; DEF0007551-DEF0007560.
- Bossler, et al.; *Accuracies Obtained by the GPSVan*; Nov. 14-16, 1995; DEF0007498-DEF0007507.
- Bossler, et al.; *GPS and GIS Map the Nation's Highways*; Mar. 1991; DEF0007473-DEF0007484.
- Bossler, et al.; *Mobile Mapping Systems: New Tools for the Fast Collection of GIS Information*; Mar. 23-25, 1993; DEF0007485-DEF0007497.
- Defendants' Fifth Supplemental Response to Plaintiff's First Set of Interrogatories (No. 6); dated Oct. 24, 2012; 90 pgs.
- Defendants' Fifth Supplemental Response to Plaintiff's First Set of Interrogatories (No. 6); dated Oct. 24, 2012; Exhibit B-15; 63 pgs.
- He, et al.; *Automatic Analysis of Highway Features from Digital Stereo-Images*; 1992; DEF0007508-DEF0007515.
- He, et al.; *The Accuracy of Features Positioned with the GPSVan*; Jun. 6-10, 1994; DEF0007516-DEF0007524.
- Proceedings 1995 Mobile Mapping Symposium, The Ohio State University Center for Mapping and Geodetic Science and Surveying; May 24-26, 1995; DEF0007525-DEF0007530.
- The Ohio State University Center for the Commercial Development of Space: *Real-Time Mapping Satellite Mapping Annual Report 1991*; 1991; DEF0007735-DEF0007774.
- The Ohio State University Center for the Commercial Development of Space: *Real-Time Mapping Satellite Mapping—Annual Report 1992*; 1992; DEF0007617-DEF0007654.
- The Ohio State University Center for the Commercial Development of Space: *Real-Time Mapping Satellite Mapping—Annual Report 1993*; 1993; DEF0007655-DEF0007680.
- The Ohio State University Center for the Commercial Development of Space: *Real-Time Mapping Satellite Mapping—Annual Report 1994*; 1994; DEF0007681-DEF0007709.
- The Ohio State University Center for the Commercial Development of Space: *Real-Time Mapping Satellite Mapping—Annual Report 1995*; 1995; DEF0007710-DEF0007734.
- Toth, Jr., M.V.; *A Conceptual Approach to Imaging for Mobile Mapping*; May 24-26, 1995; DEF0007540-DEF0007550.
- Toth, C.; *Experiences with a Fully Digital Image Acquisition System*; Feb. 27, 1995; DEF0007531-DEF0007539.
- Bove, Jr., M.V.; "Pictorial Applications For Range Sensing Cameras"; *Proceedings, SPIE vol. 901; Image Processing, Analysis, Measurement, and Quality*; Los Angeles, CA, Jan. 13-15, 1988; DEF0007830-DEF0007840; 11 pages.
- Discursions Architecture Machine Group; Scitex, MIT 1983; DEF0007781-DEF0007782; 2 pages.
- El-Shelmy, N.; "A GPS/INS Aided Video Camera System for Rapid GIS Surveys in Urban Centers"; *The Institute of Navigation, Proceedings of ION GPS-94; 7th International Technical Meeting of the Satellite Division of the Institute of Navigation*; Part 2, Salt Palace Convention Center, Salt Lake City, Utah; Sep. 20-23, 1994; DEF0006761-DEF0006771; 11 pgs.
- Friedman, G. L.; "The Trustworthy Digital Camera: Restoring Credibility to the Photographic Image," *IEEE Transactions on Consumer Electronics*, Nov. 1993, vol. 39, No. 4; DEF0007861-DEF0007868; 8 pages.
- Glenn, S.; "Real Fun, Virtually: Virtual Experience Amusements and Products in Public Space Entertainment"; *Beyond The Vision, The Technology, Research, and Business of Virtual Reality*; *Proceedings of Virtual Reality '91, The Second Annual Conference on Virtual Reality, Artificial Reality, and Cyberspace*; San Francisco, Sep. 23-25, 1991; DEF0007841-DEF0007850; 10 pages.
- Goad, C.C.; "The Ohio State University Highway Mapping Project: The Positioning Component"; *Department of Geodetic Science and Surveying, The Ohio State University*; DEF0008553-DEF0008556; 4 pages.
- He, G., et al.; "Spatial Data Collection With The GPSVan Mobile Mapping System"; *ISPRS International Society for Photogrammetry and Remote Sensing*, vol. 30, Part 4; *Proceedings of the Symposium Mapping and Geographic Information Systems*; May 31-Jun. 3, 1994, Athens, GA; DEF0008470-DEF0008479; 10 pages.

(56)

References Cited

OTHER PUBLICATIONS

- Ince, I, et al.; "Virtuality and Reality: A Video/Graphics Environment for Teleoperation"; Conference Proceedings, 1991 IEEE International Conference on Systems, Man, and Cybernetics; Oct. 13-16, 1991, vol. 2, School of Engineering and Applied Science; DEF0007878-DEF0007886; 9 pages.
- Loveria, G., et al.; "MultiMedia: DVI Arrives"; Byte IBM Special Edition; Seventh Annual Extra All-IBM Edition; "Guideposts for the 90s"; vol. 15, No. 11, Fall, 1990; DEF0007785-DEF0007790; 6 pages.
- McDonald, N.H., et al.; "Video Graphic Query Facility Database Design"; Department of Computer Science and Engineering; University of South Florida, Tampa, Florida 33620; 1981; DEF0008568-DEF0008577; 10 pages.
- McKeown, Jr., D. M., et al.; "Research in Automated Analysis of Remotely Sensed Imagery"; Proceedings: Image Understanding Workshop; Defense Advanced Research Projects Agency, Apr. 1993; DEF0006831-DEF0006860; 30 pages.
- Naimark, M.; "Elements of Realspace Imaging: A Proposed Taxonomy"; Proceedings SPIE—The International Society for Optical Engineering; Stereoscopic Displays and Applications II; vol. 1457; San Jose, CA; Feb. 25-27, 1991; DEF0007791-DEF0007804; 14 pp.
- Nitao, J. J., et al.; "Computer modelling: a structured light vision system for a Mars rover"; Proceedings, Mobile Robots IV; Nov. 6-7, 1989, Philadelphia, PA; SPIE vol. 1195; DEF0006877-DEF0006887; 11 pages.
- Novak, K.; "Application of Digital Cameras and GPS For Aerial Photogrammetric Mapping"; ISPRS, Washington, D.C., 1992; International Archives of Photogrammetry and Remote Sensing; vol. XXIX, Part B4; DEF0008527-DEF0008540; 14 pages.
- Schwarz, K. P., et al.; "VIASAT—A Mobile Highway Survey System of High Accuracy"; Proceedings of the IEEE-IEE Vehicle Navigation and Information Systems Conference; Ottawa, Ontario, Oct. 12-15, 1993; DEF0007869-DEF0007877; 9 pages.
- Teodosio, L. A.; "Panoramic Overviews for Navigating Real-World Scenes"; Proceedings ACM Multimedia 93, Anaheim, CA, Aug. 1-6, 1993; DEF0007822-DEF0007829; 8 pages.
- The Center for Mapping, The Ohio State University, Columbus, OH; Dec. 1, 1991; "The GPS/Imaging/GIS Project"; Application of the Global Positioning System for Transportation Planning: A Multi-State Project; DEF0008244-DEF0008460; 214 pages.
- Tomasi, C., et al.; "Shape and Motion From Image Streams: A Factorization Method"; Proceedings of the National Academy of Sciences of the United States of America; Nov. 1, 1993, vol. 90, No. 21; DEF0007851-DEF0007860; 10 pages.
- Toth, C.K.; "Imaging Component of Mobile Mapping Systems", brochure; Center for Mapping; The Ohio State University; DEF0008494-DEF0008526; 33 pages.
- Ware, C., et al.; "Exploration and Virtual Camera Control in Virtual Three Dimensional Environments"; Proceedings 1990 Symposium on Interactive 3D Graphics; Snowbird, Utah, Mar. 25-28, 1990; DEF0007805-DEF0007816; 12 pages.
- Zhou, Q., et al.; "Development of a Multimedia Spatial Information System"; ISPRS, Washington, D.C., 1992; International Archives of Photogrammetry and Remote Sensing; vol. XXIX, Part B2; DEF0008541-DEF0008552; 12 pages.
- Poelman, C.J., et al.; "A Paraperspective Factorization Method for Shape and Motion Recovery"; Oct. 29, 1992; DEF0004181-DEF0004210.
- Poelstra, T.J.; "The Frank System: First Results"; 1993; DEF0006473-DEF0006483.
- Ressler, S.; "Approaches Using Virtual Environments with Mosaic"; Dec. 22, 1994; DEF0006484-DEF0006491.
- Robinett, W.; "Synthetic Experience: A Taxonomy, Survey of Earlier Thought, and Speculations on the Future"; DEF0006905-DEF0006934.
- San Francisco Walking Tour Video; 1994; DEF0005850.
- Schachter, B.J.; "Computer Image Generation"; 1983; DEF0006503-DEF0006750.
- Shenchang, E.; "QuickTime VR—An Imaged-Based Approach to Virtual Environment Navigation"; 1995; DEF0005177-DEF0005186.
- Sniffer, M.; Augmenting Geographic Information with Collaborative Multimedia Technologies; Nov. 1989; DEF0006935-DEF0006952.
- Smith, K.W.; "Verkenningberekeningen Met Het Frank-System"; Sep. 1991; DEF0006363-DEF0006472.
- Stanton, D.; Fire Drill Couldn't Chase Us Away From NECC's Multimedia Demos; Oct. 1989; DEF0005355-DEF0005356.
- Szeliski, R.; "Image Alignment and Stitching: A Tutorial"; Dec. 10, 2006; DEF0004294-DEF0004382.
- Teaching and Research—Using Technology Tools—1988 OIT Colloquium Series; DEF0005366-DEF0005370.
- The Aspen Institute Chronicle, "Enhancing the Social Benefits of New Electronic Technologies"; vol. 2, No. 4; Winter, 1988; DEF0004233-DEF0004238.
- The Development of the Frank Surveying System and the Frank Image Viewing System; Jul. 1993; DEF0006290-DEF0006295.
- The Frank Image Retrieval System; DEF0006288-DEF0006289.
- Tomasi, C, et al.; "Shape and Motion from Image Streams: a Factorization Method—Full Report on the Orthographic Case"; Mar. 1992; DEF0005202-DEF0005235.
- Tsai, R.Y.; "A Versatile Camera Calibration Technique for High-Accuracy 3D Machine Vision Metrology Using Off-the-Shelf TV Cameras and Lenses"; Aug. 1987; DEF0004211-DEF0004232.
- Vincent, L.; "Taking Online Maps Down to Street Level"; Dec. 2007; DEF0005363-DEF0005395.
- Wilson, K., et al.; "Palenque Project Production Plan"; Mar. 24, 1986; DEF0005147-DEF0005168.
- Wilson, K.; "The Palenque Design: Children's Discovery Learning Experiences in an Interactive Multimedia Environment"; 1988; DEF0004436-DEF0004695.
- Wilson, K.S.; "Bank Street College of Education for Children and Technology, Palenque: A Multimedia Video Interactive Prototype for Children"; Jun. 1990; DEF0005632-DEF0005645.
- Wilson, K.S.; "Palenque Project Design"; Mar. 1986; DEF0005646-DEF0005715.
- Wilson, K.S.; "The Palenque Optical Disc Prototype: Design of Multimedia Experiences for Education and Entertainment in a Non-traditional Learning Content"; 1988; DEF0003611-DEF0003629.
- Wolters, K.; "Beeldmatching Tijends Het Frank-Meetproces"; 1994; DEF0006182-DEF0006287.
- Appendix to Plaintiff Transcenic, Inc.'s Claim Construction Opening Brief dated Sep. 6, 2012; 96 pages.
- Appendix to Plaintiff Transcenic, Inc.'s Claim Construction Answering Brief dated Oct. 5, 2012; 490 pages.
- Declaration of Anne Shea Gaza in Support of Defendants' Opening Claim Construction Brief dated Sep. 6, 2012; 23 pages.
- Declaration of Dr. Chandrajit L. Bajaj dated Sep. 6, 2012; 218 pages.
- Declaration of Jason J. Rawnsley in Support of Defendants' Responsive Claim Construction Brief dated Oct. 5, 2012; 21 pages.
- Declaration of Joseph L. Mundy on Behalf of Defendants dated Oct. 5, 2012; 105 pages.
- Defendants' Opening Claim Construction Brief dated Sep. 6, 2012; 39 pages.
- Defendants' Responsive Claim Construction Brief dated Oct. 5, 2012; 61 pages.
- Joint Claim Construction Chart filed Jul. 30, 2012; 254 pages.
- Plaintiff Transcenic, Inc.'s First Supplemental Responses and Objections to Defendants' Second Set of Common Interrogatories (No. 4) including exhibits, dated Jan. 20, 2013; 499 pages.
- Transcenic's Amended Claim Construction Chart dated Sep. 6, 2012; 16 pages.
- Transcenic's Claim Construction Answering Brief dated Oct. 5, 2012; 30 pages.
- Transcenic's Claim Construction Opening Brief dated Sep. 6, 2012; 37 pages.
- Plaintiff Transcenic, Inc.'s Responses and Objections to Defendants' Second Set of Common Interrogatories (No. 4); dated May 18, 2012; 1459 pgs.

(56)

References Cited

OTHER PUBLICATIONS

Order for Memorandum Opinion issued Sep. 17, 2013, in litigation case No. 11-cv-582 pending in the U.S. District Court for the District of Delaware; 5 pages.

Memorandum Opinion regarding claim construction for U.S. Pat. No. RE42,289, dated Sep. 17, 2013, in litigation case No. 11-cv-582

pending in the U.S. District Court for the District of Delaware; 19 pages.

Jane Radatz, "gimbal", The IEEE Standard Dictionary of Electrical and Electronic Terms, 1997, New York, NY: IEEE Standards Office, Sixth Edition, p. 454.*

* cited by examiner

Fig. 1

SPATIALLY REFERENCED CAMERA

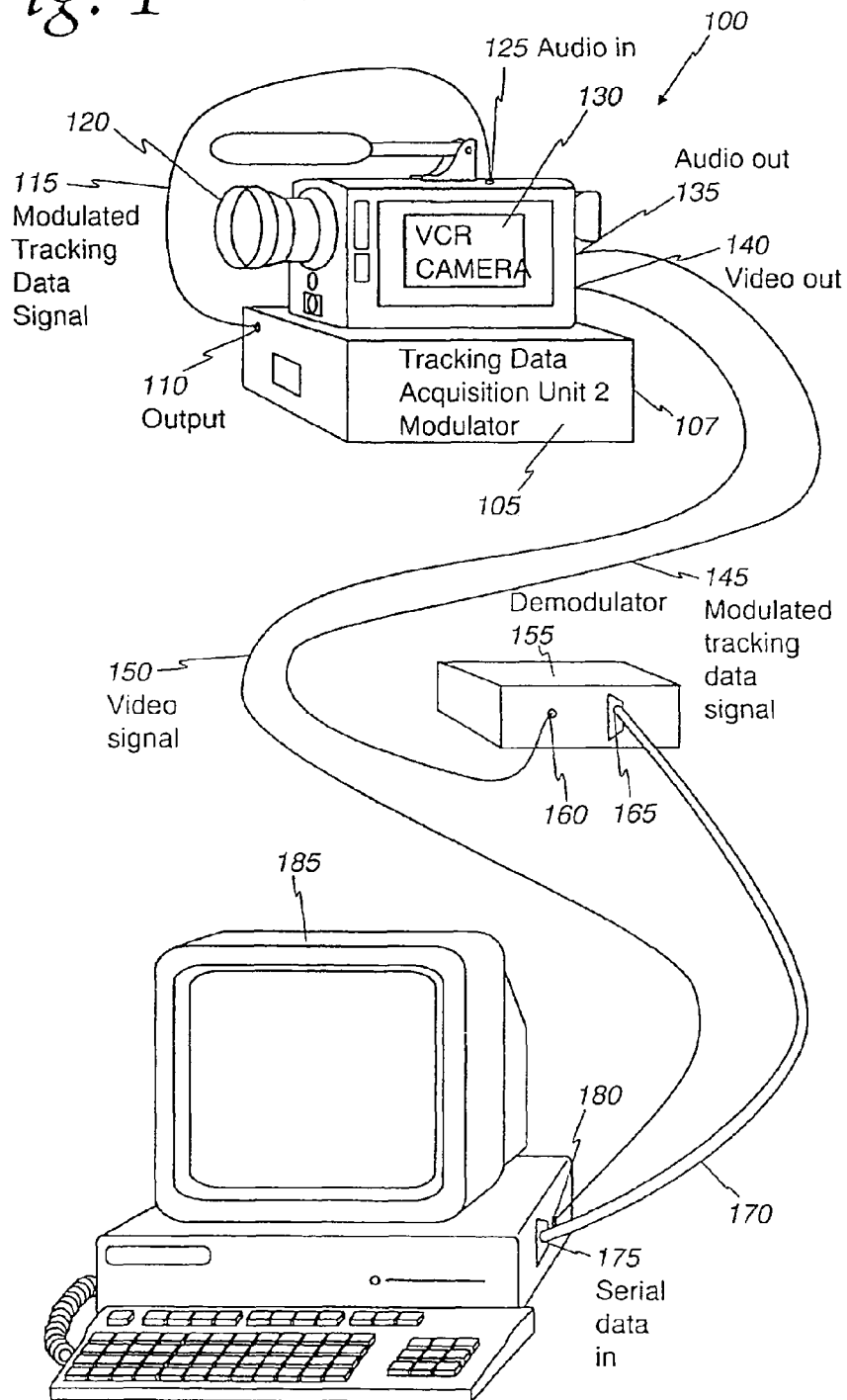

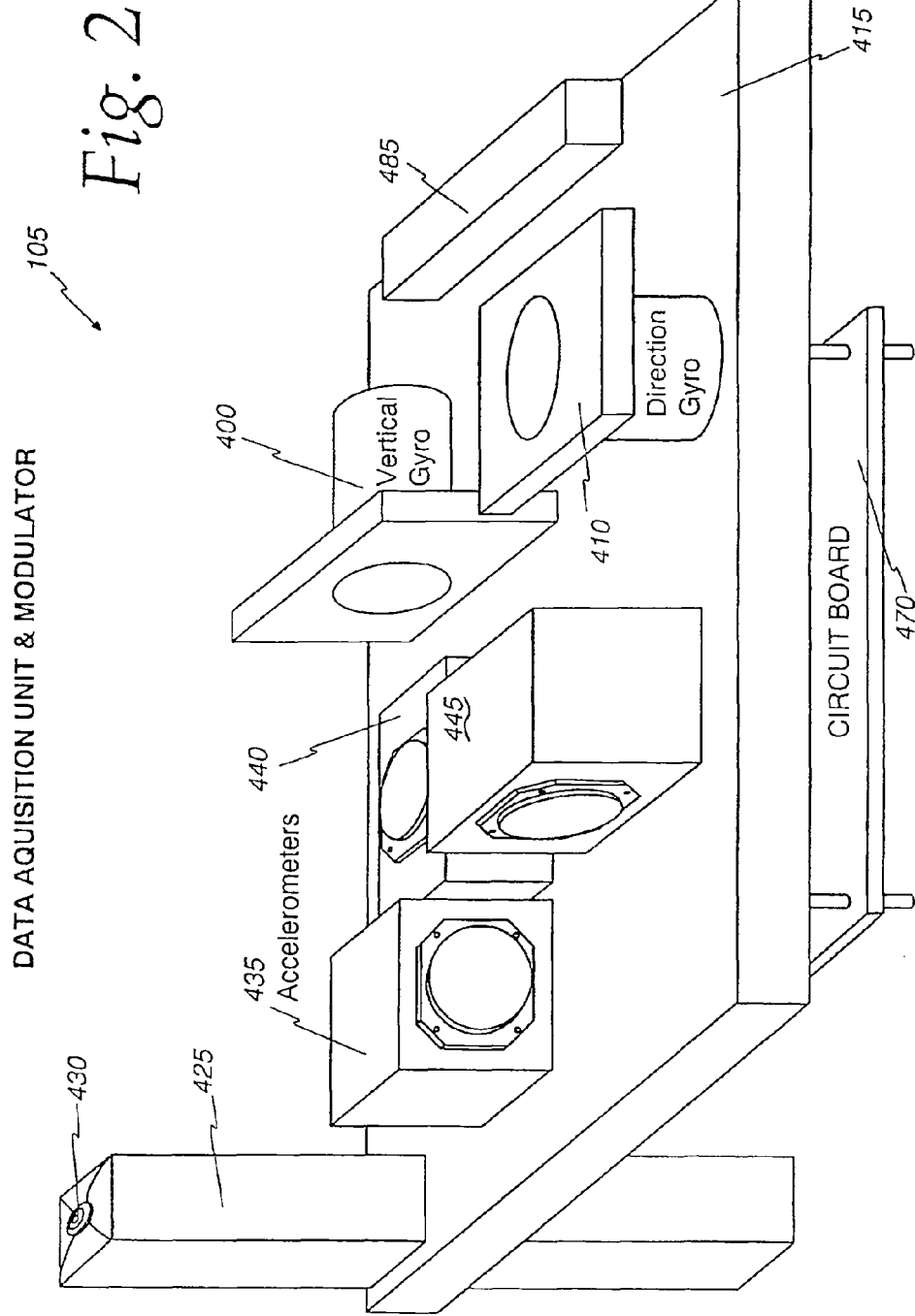

Fig. 3

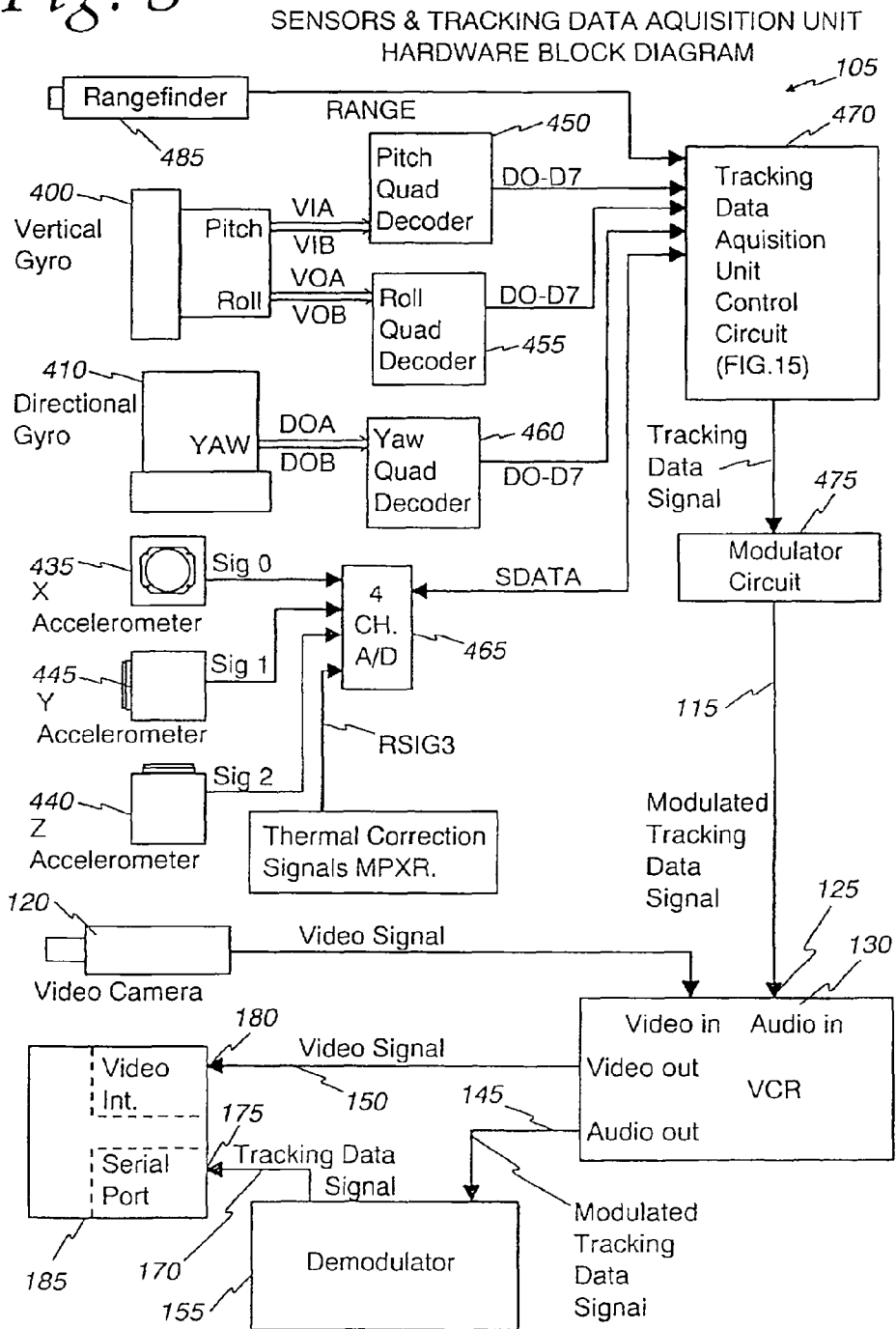

Fig. 4 TRACKING DATA ACQUISITION UNIT - DATA FORMAT DIAGRAM

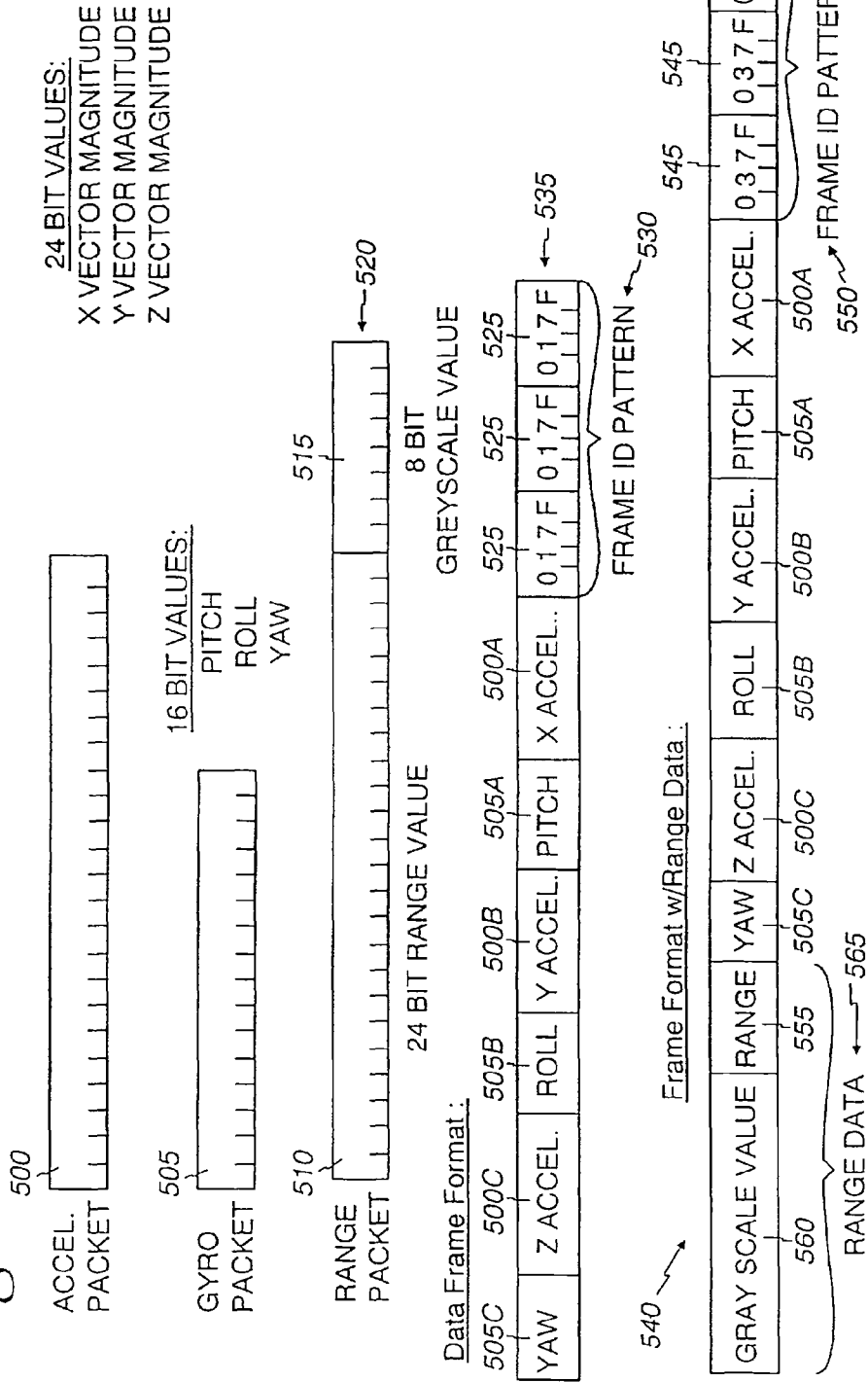

Fig. 5

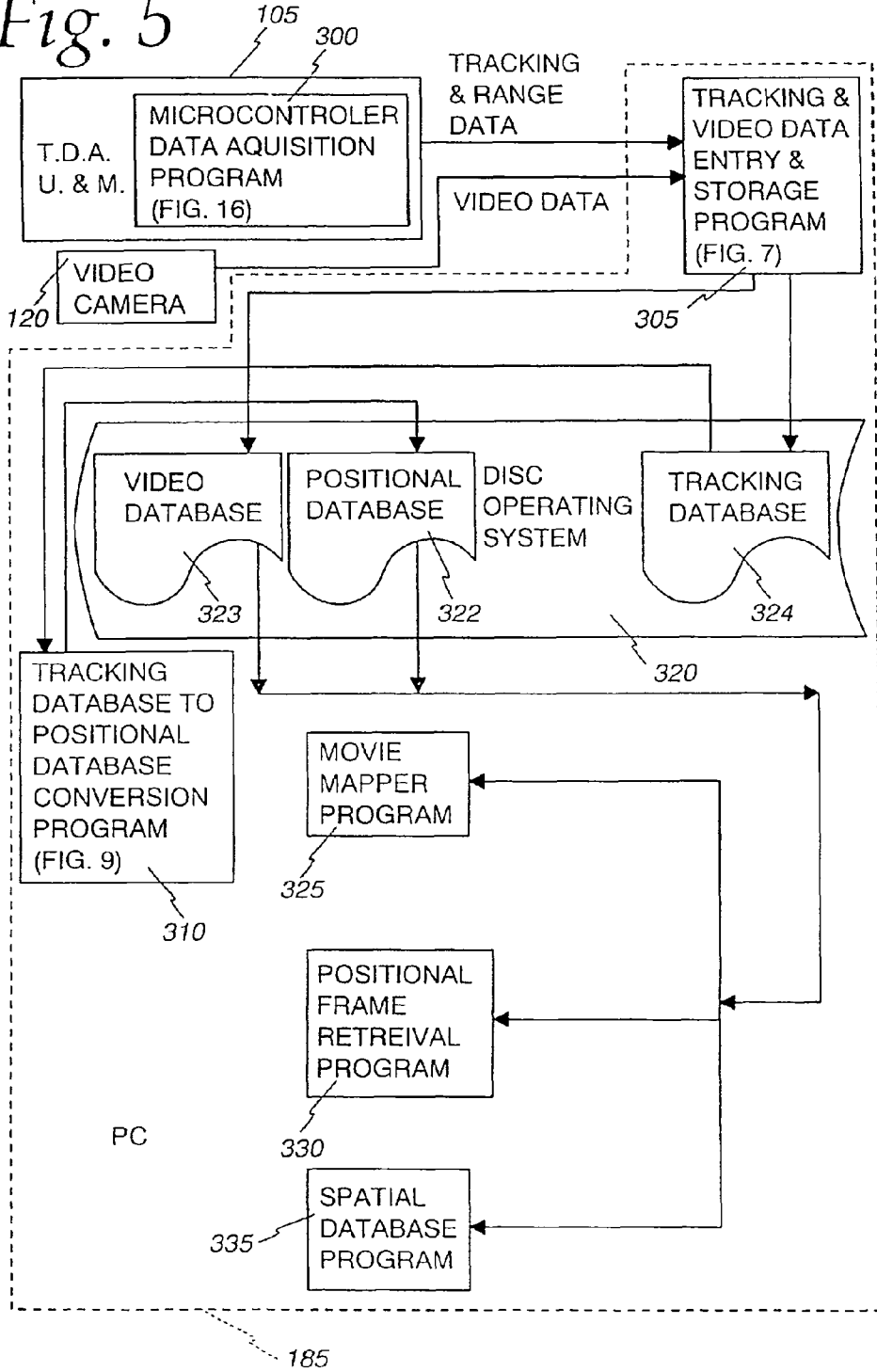

Fig. 6

TRACKING DATA ACQUISITION UNIT DATA FLOW DIAGRAM

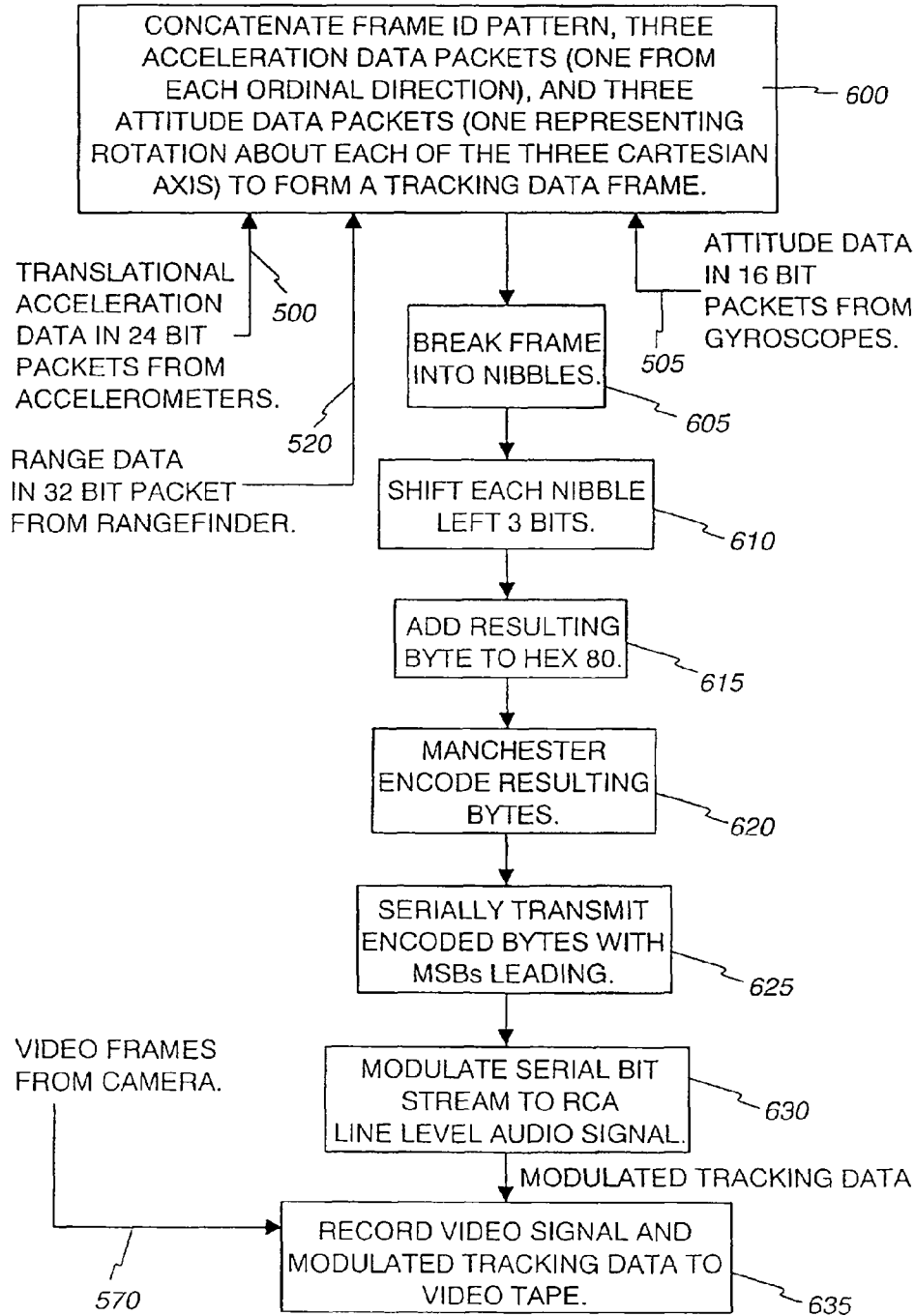

Fig. 7

TRACKING AND VIDEO DATA ENTRY AND STORAGE PROGRAM DATA FLOW DIAGRAM

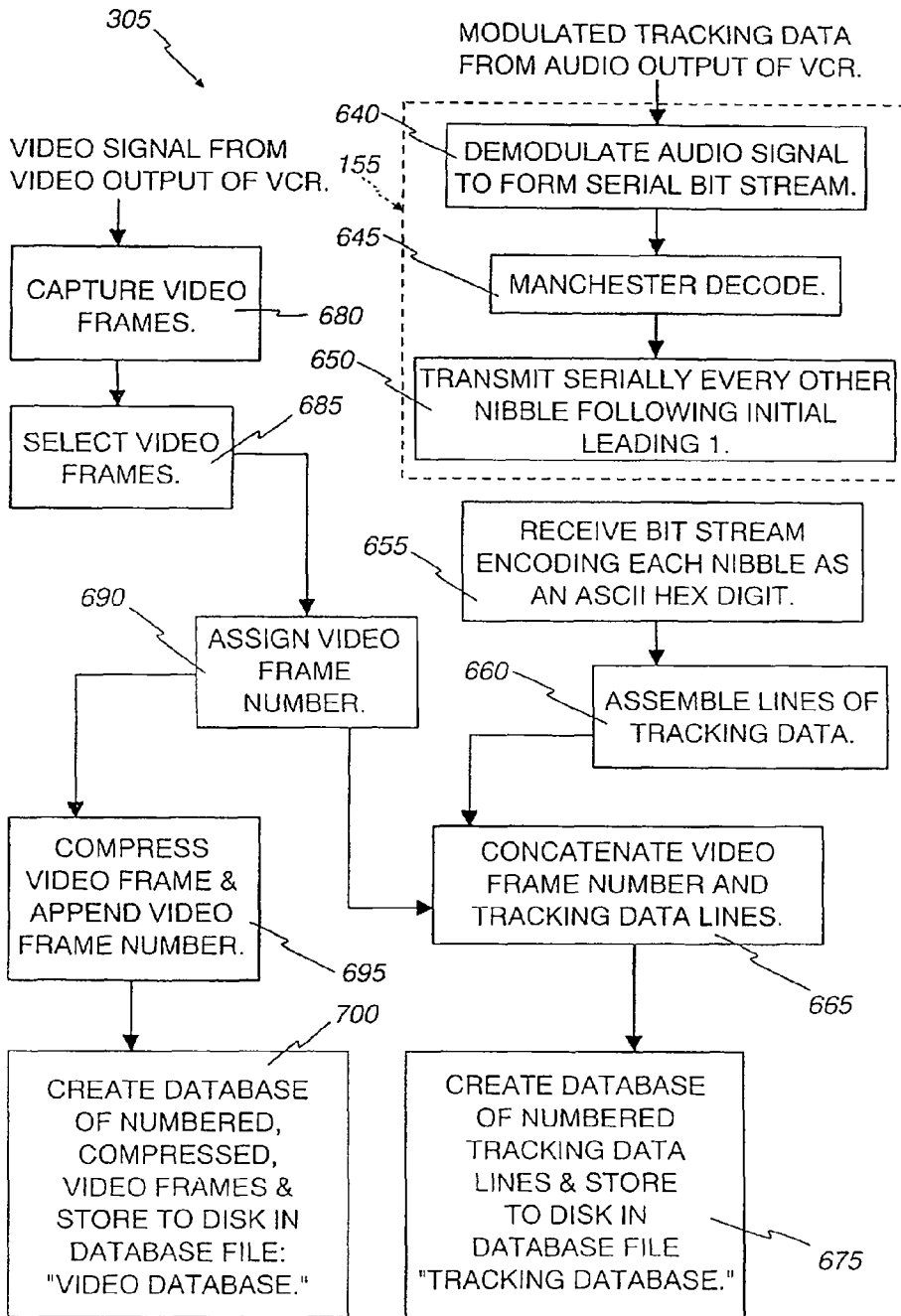
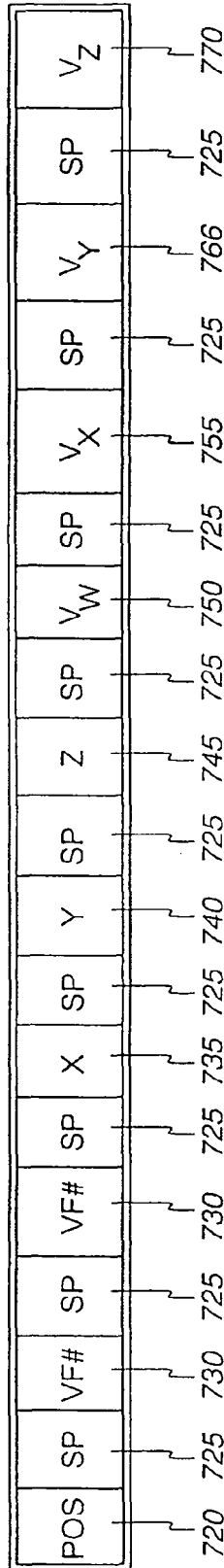

Fig. 8

POSITIONAL DATA RECORD FORMAT

715

QUATERNION POSITION NOTATION RECORD FORMAT



775

DIRECT ANGULAR NOTATION RECORD FORMAT

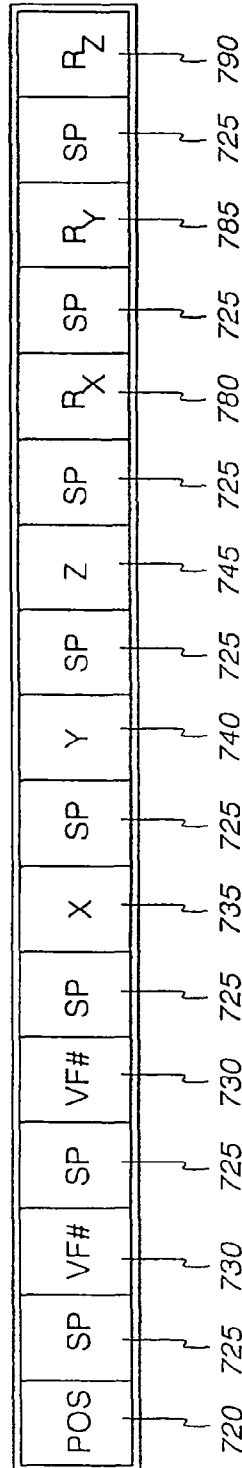

Fig. 9

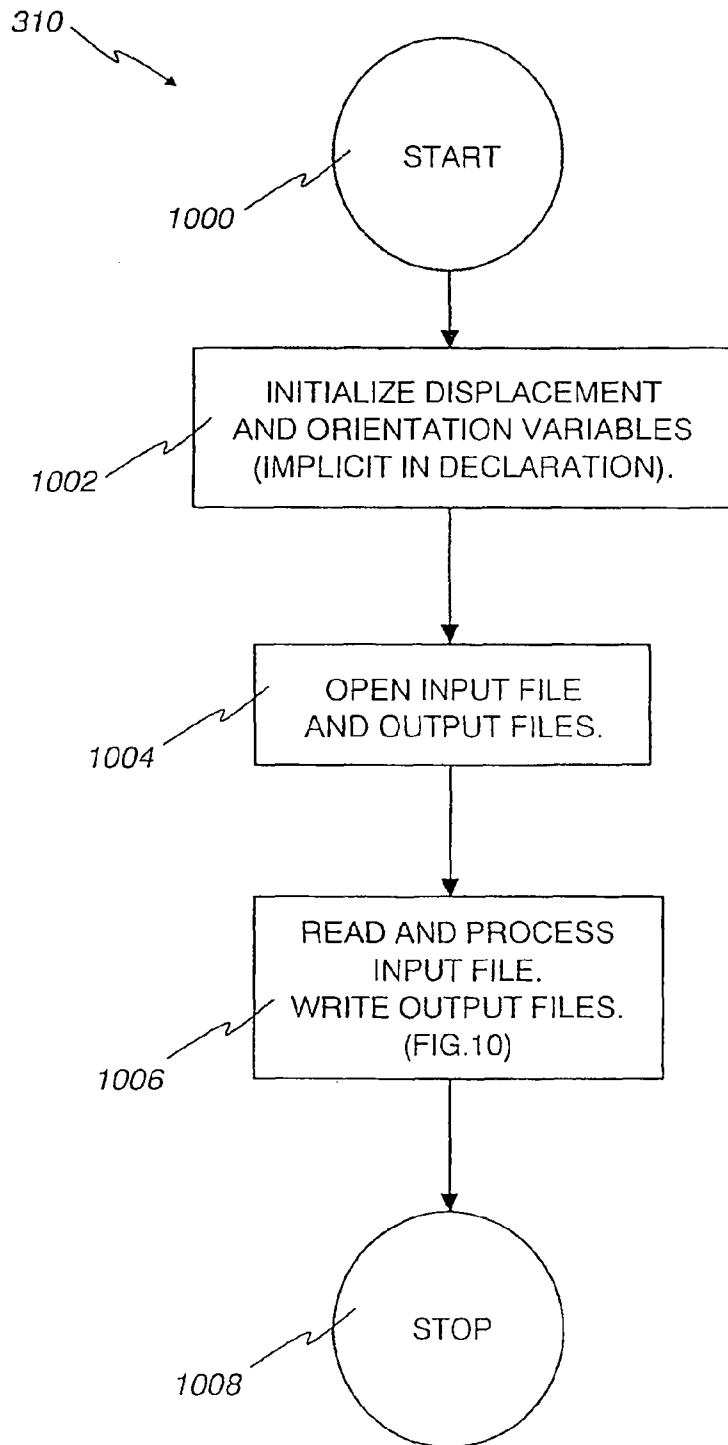

Fig. 10

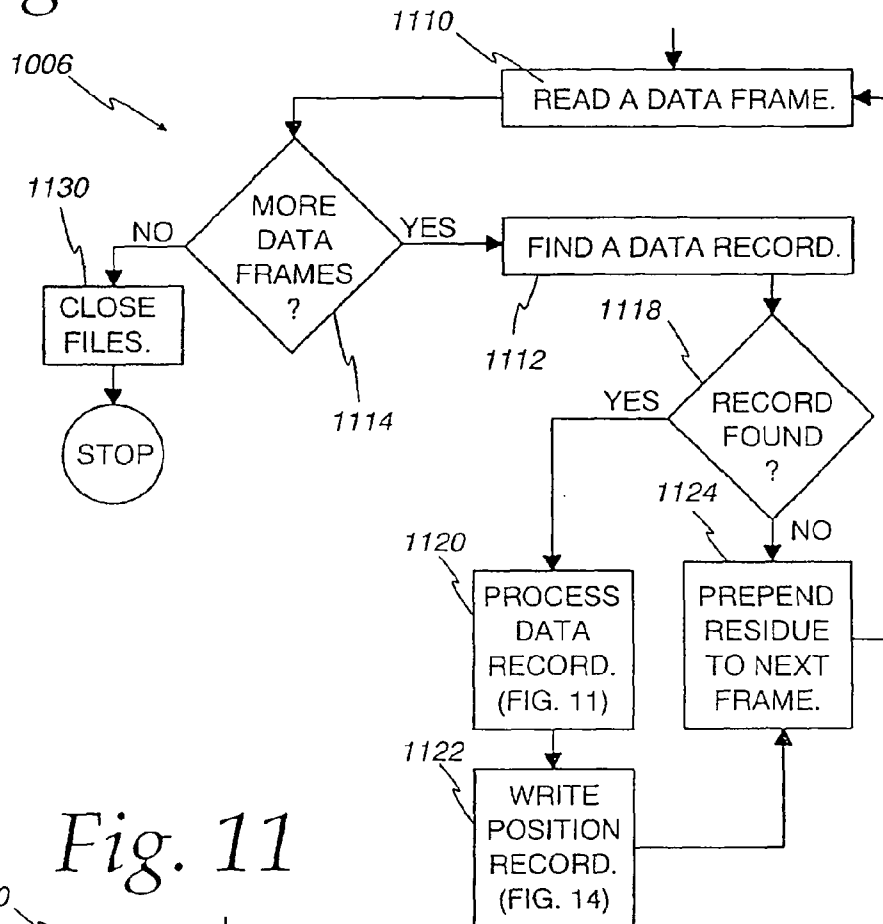

Fig. 11

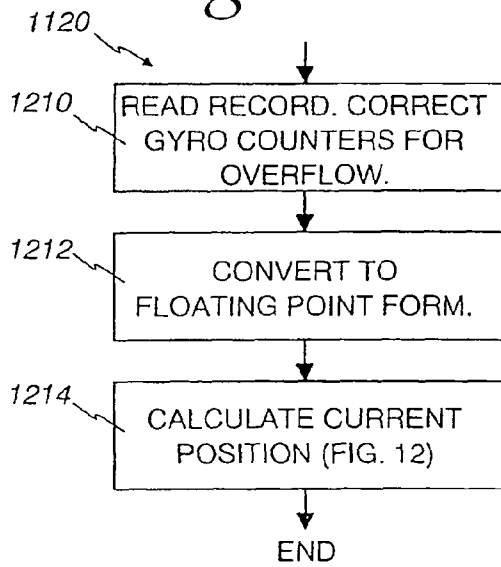

Fig. 12

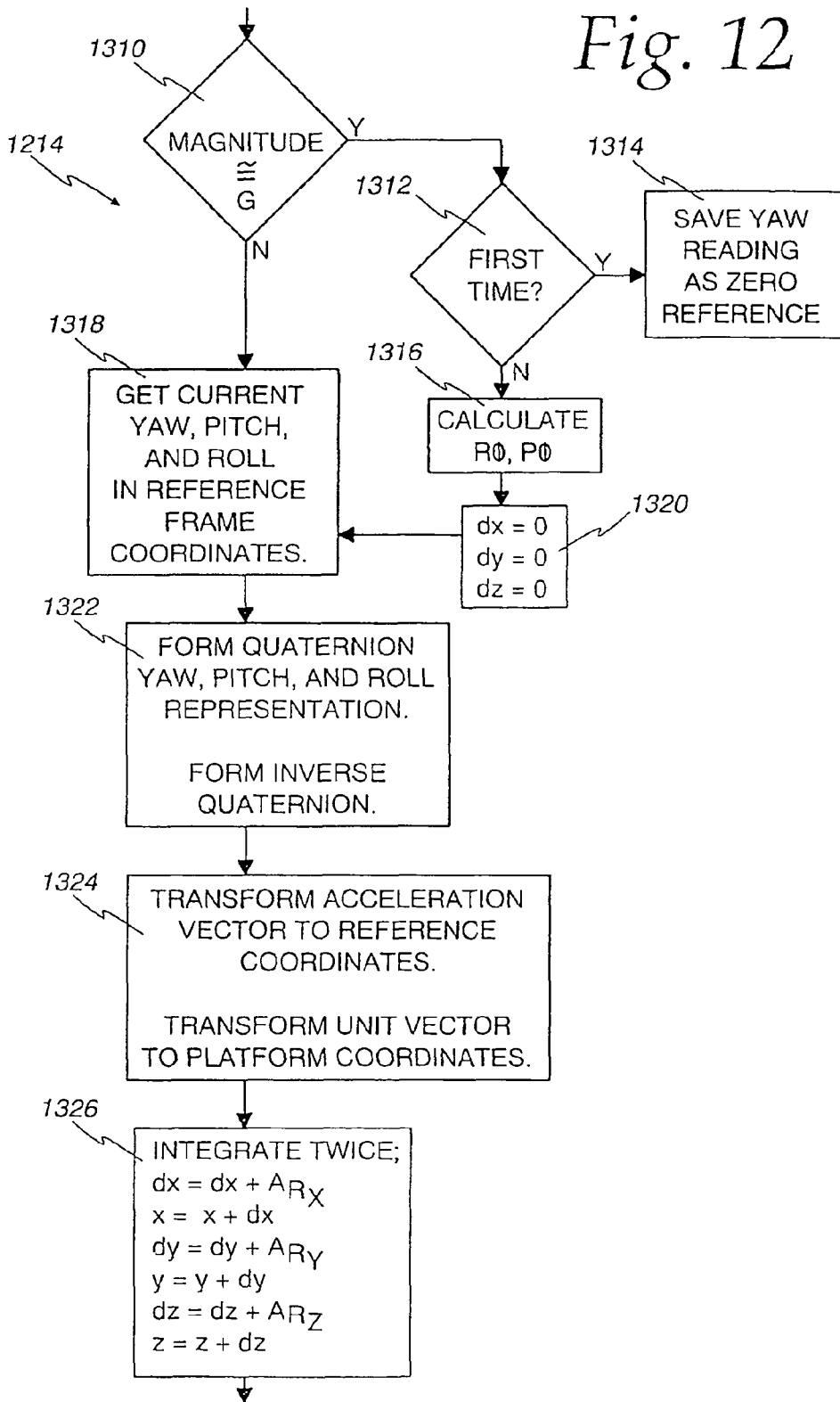

Fig. 13

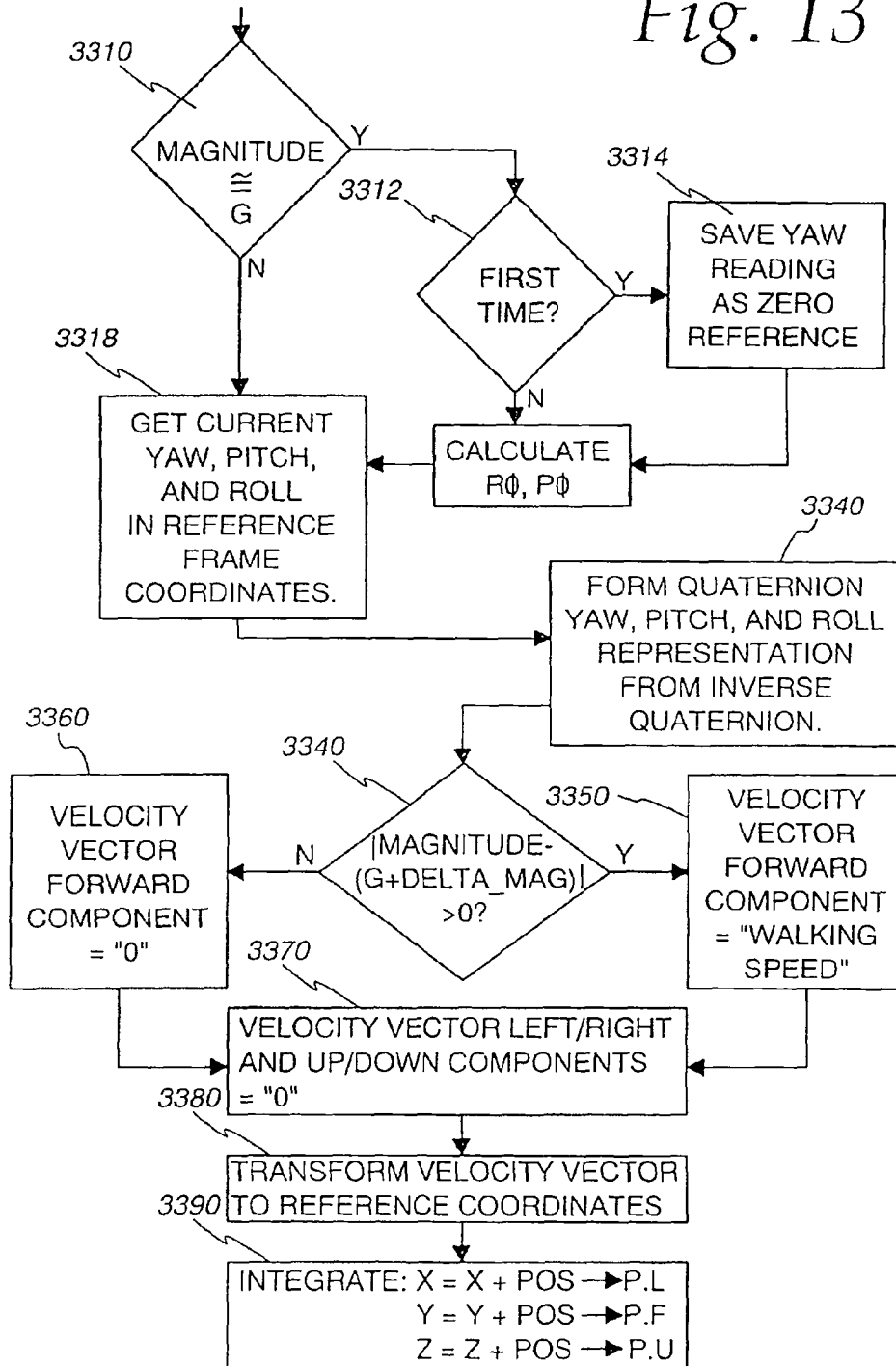

Fig. 14

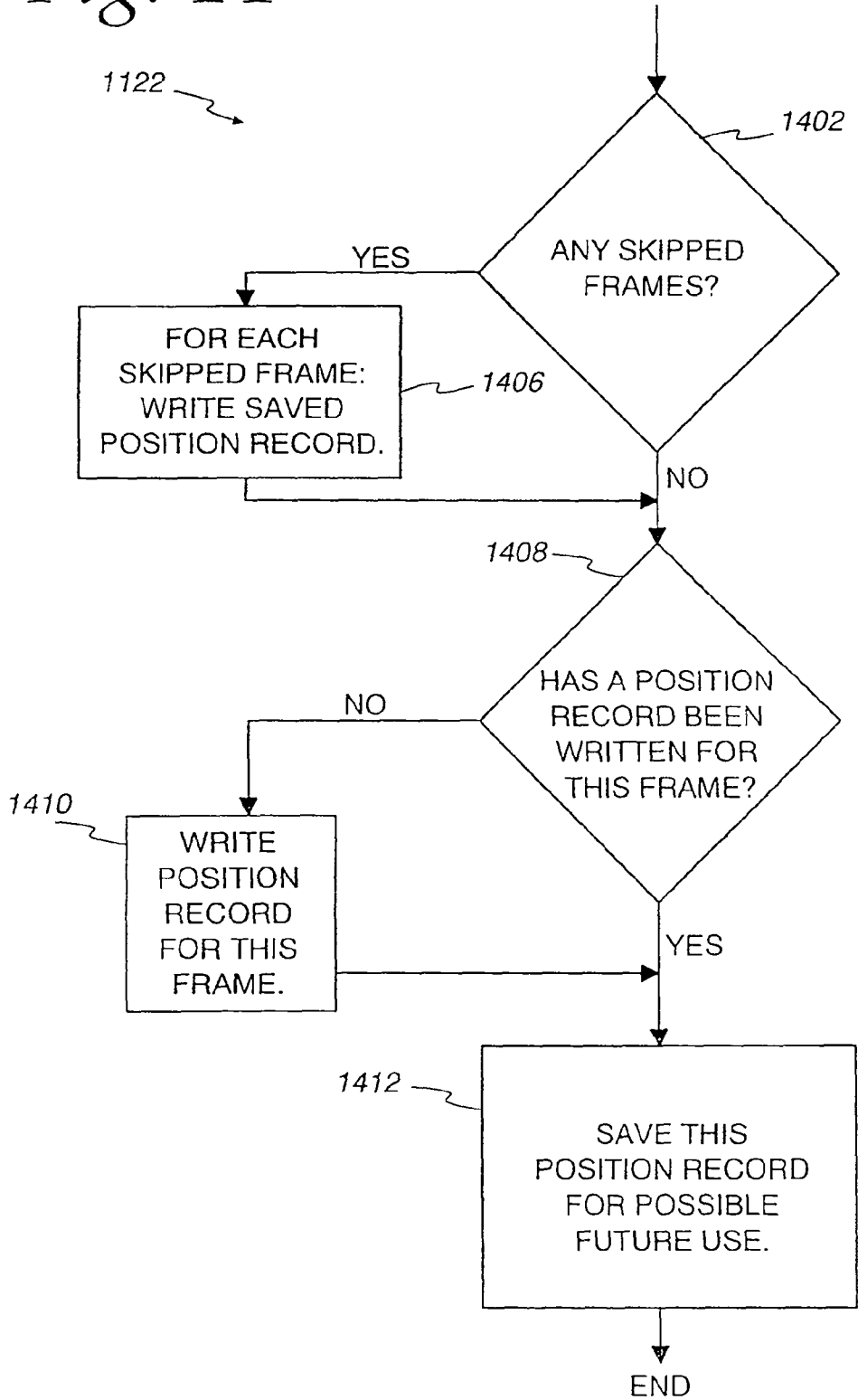

Fig. 15A

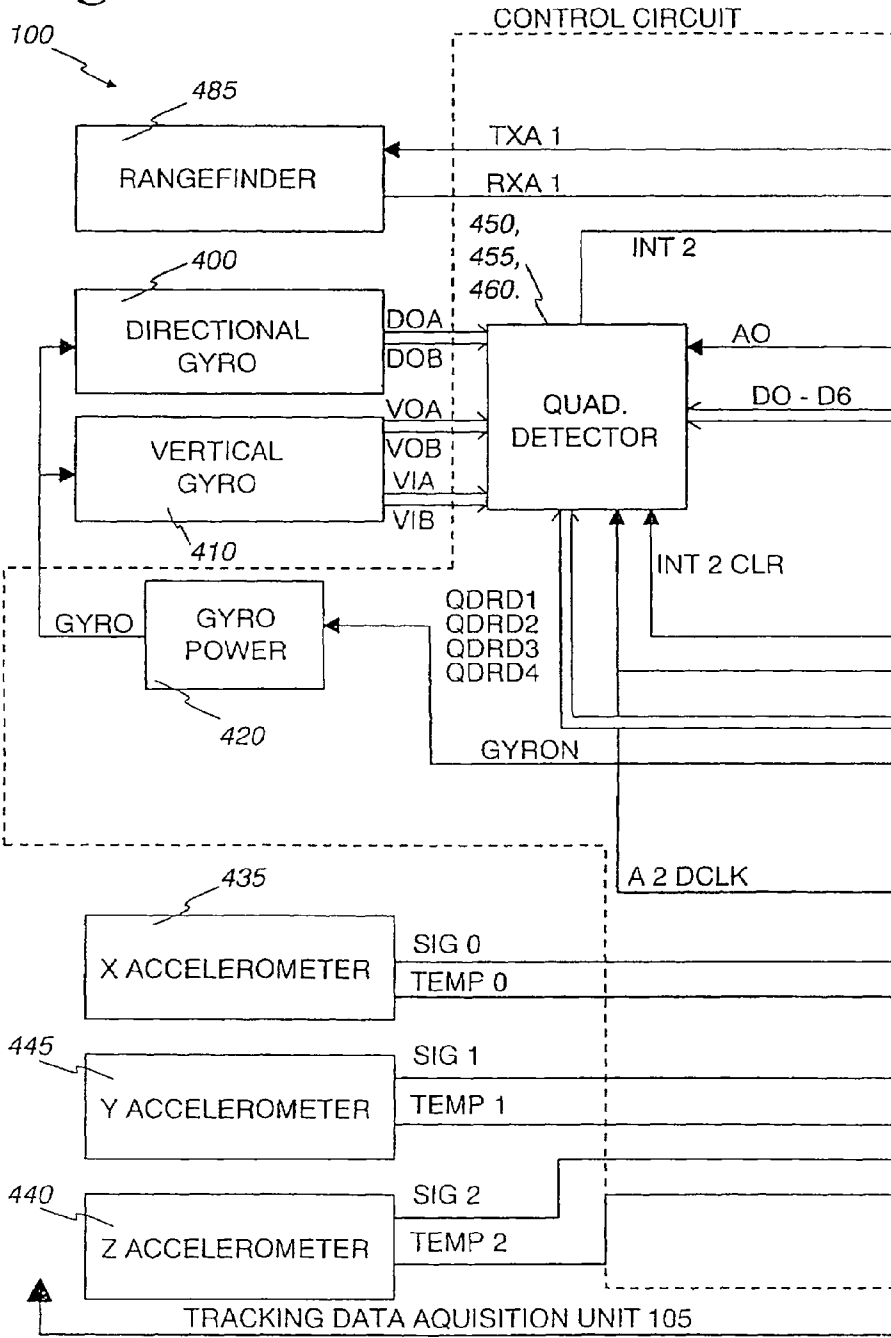

Fig. 15B

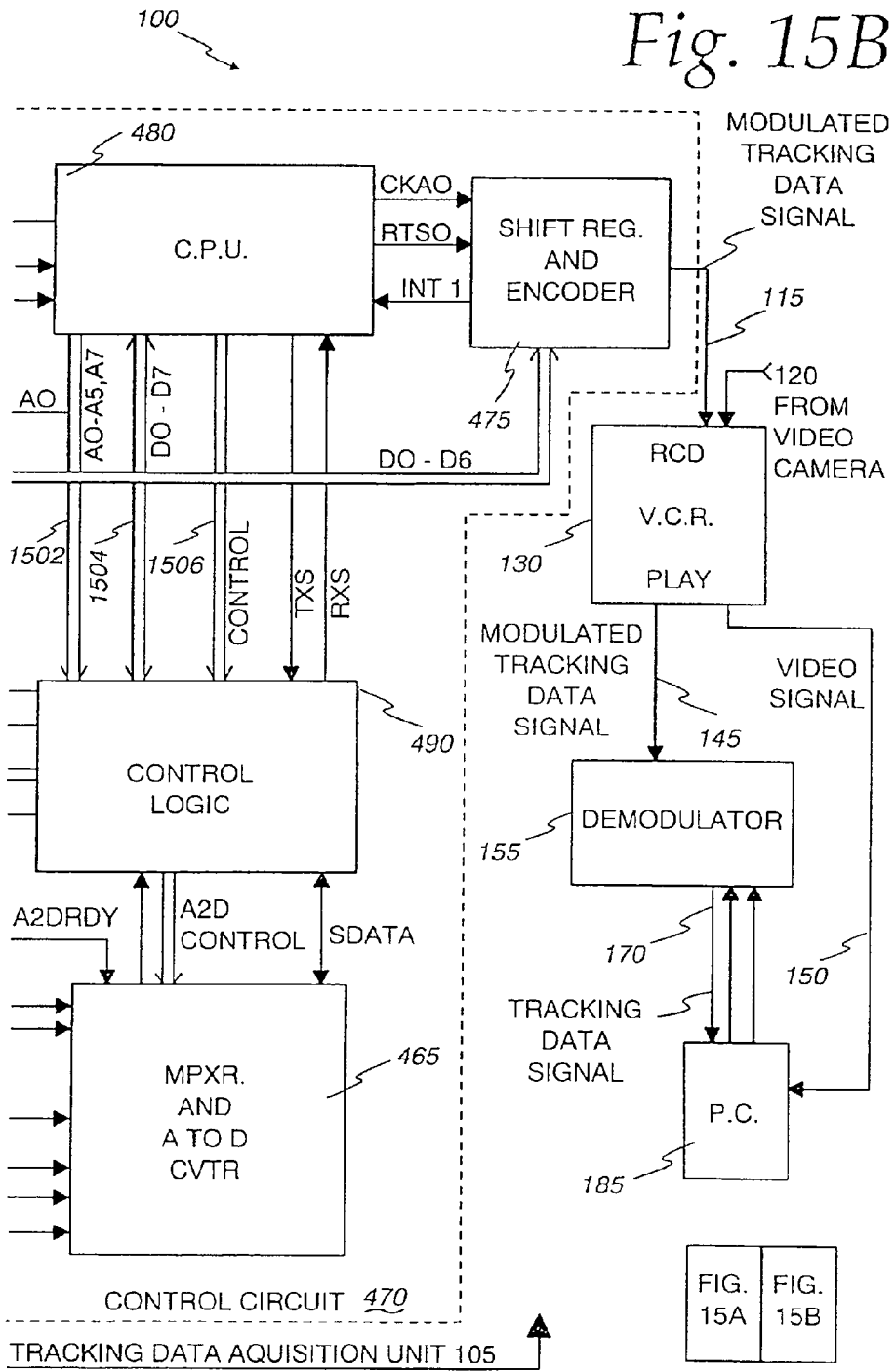

FIG. 15A	FIG. 15B
----------	----------

Fig. 16

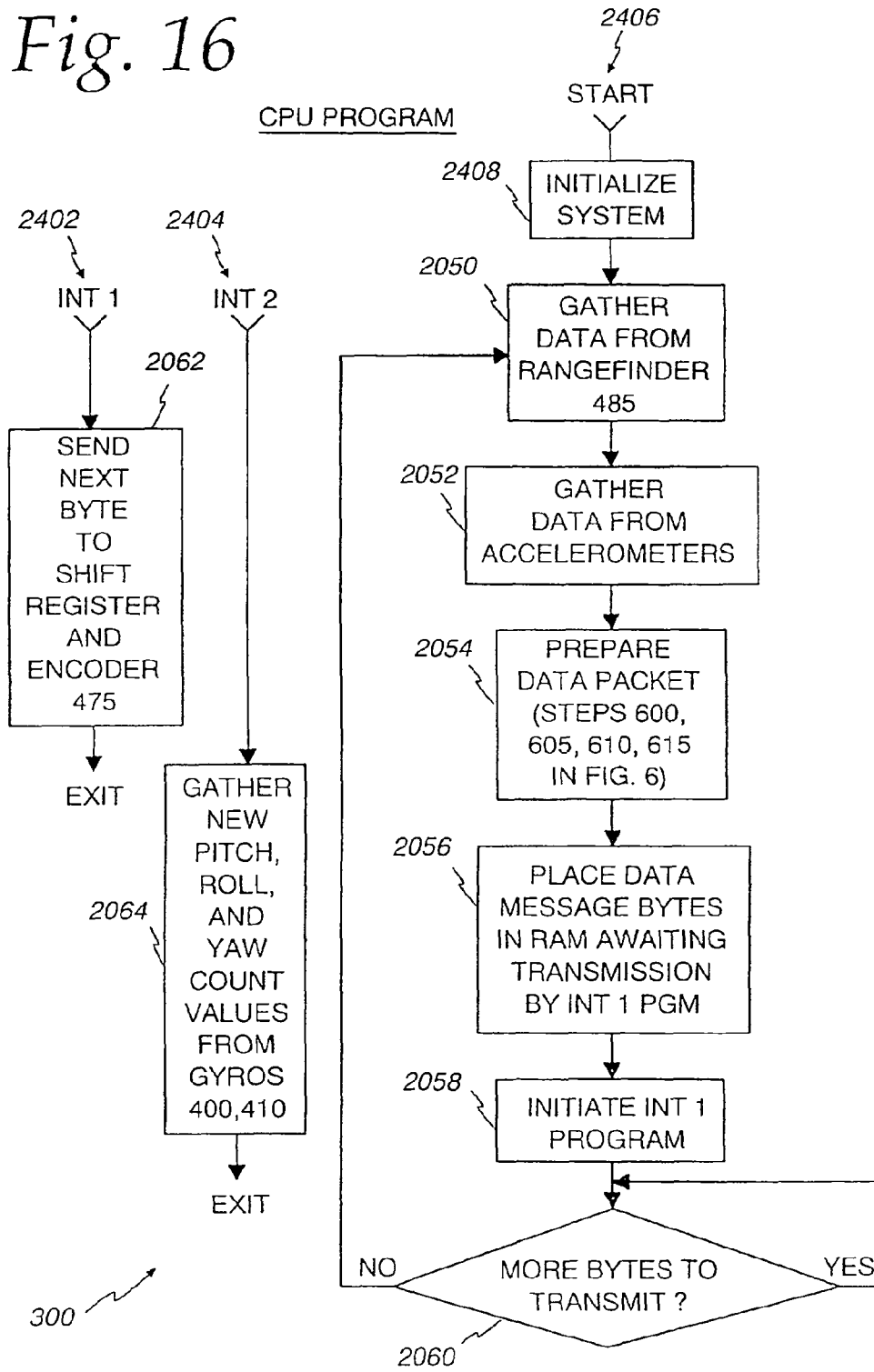

Fig. 17

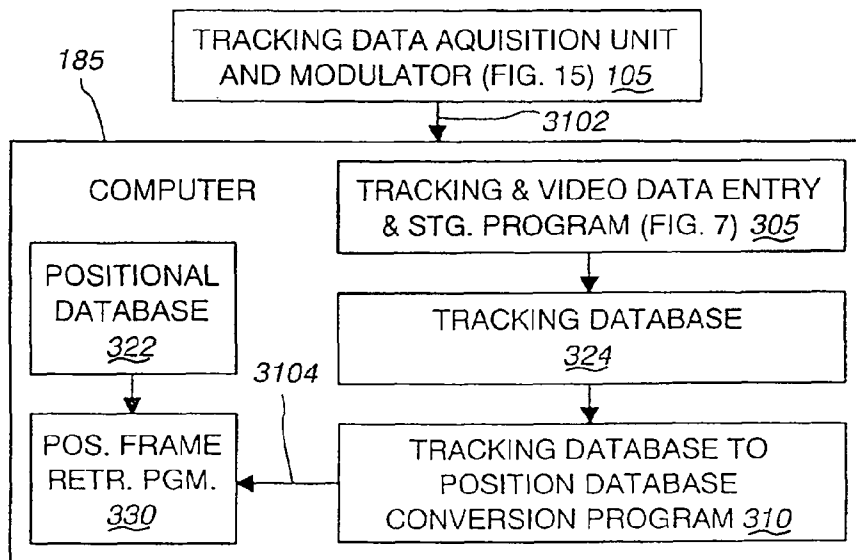

Fig. 18

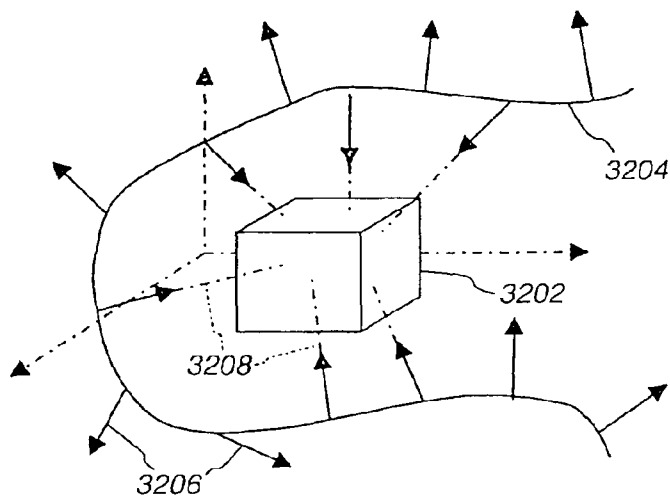

Fig. 20

10220

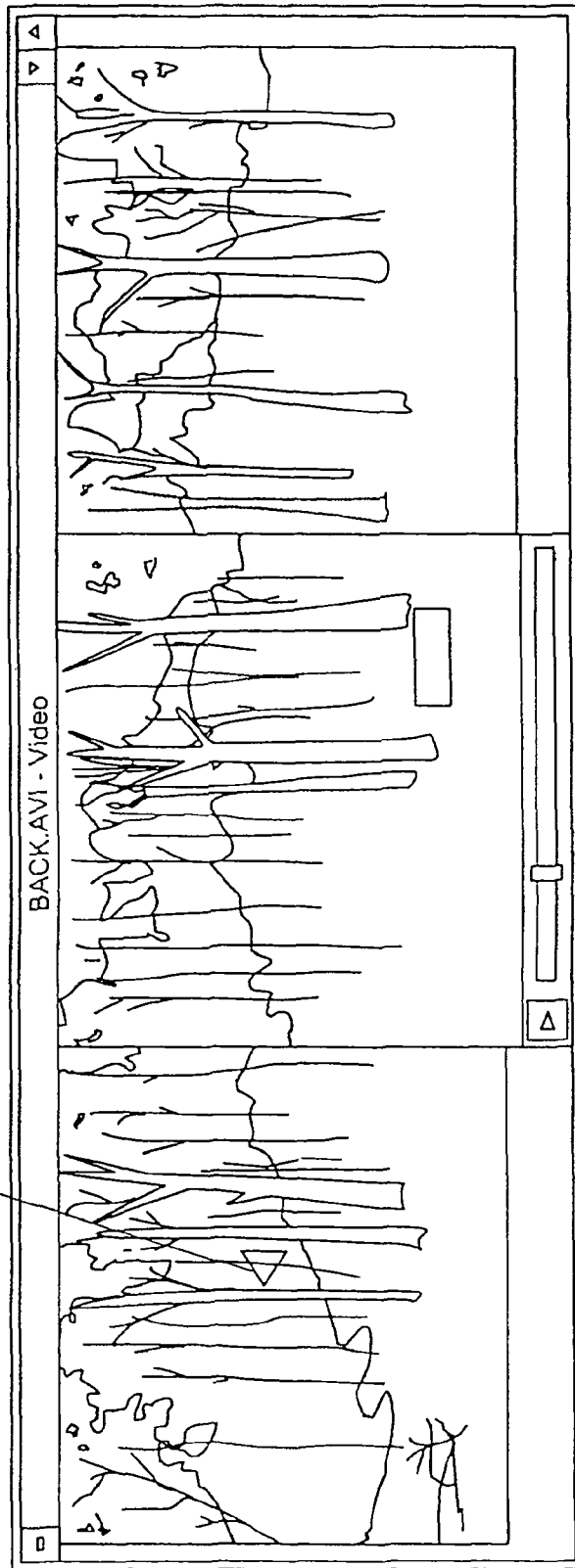

Fig. 21

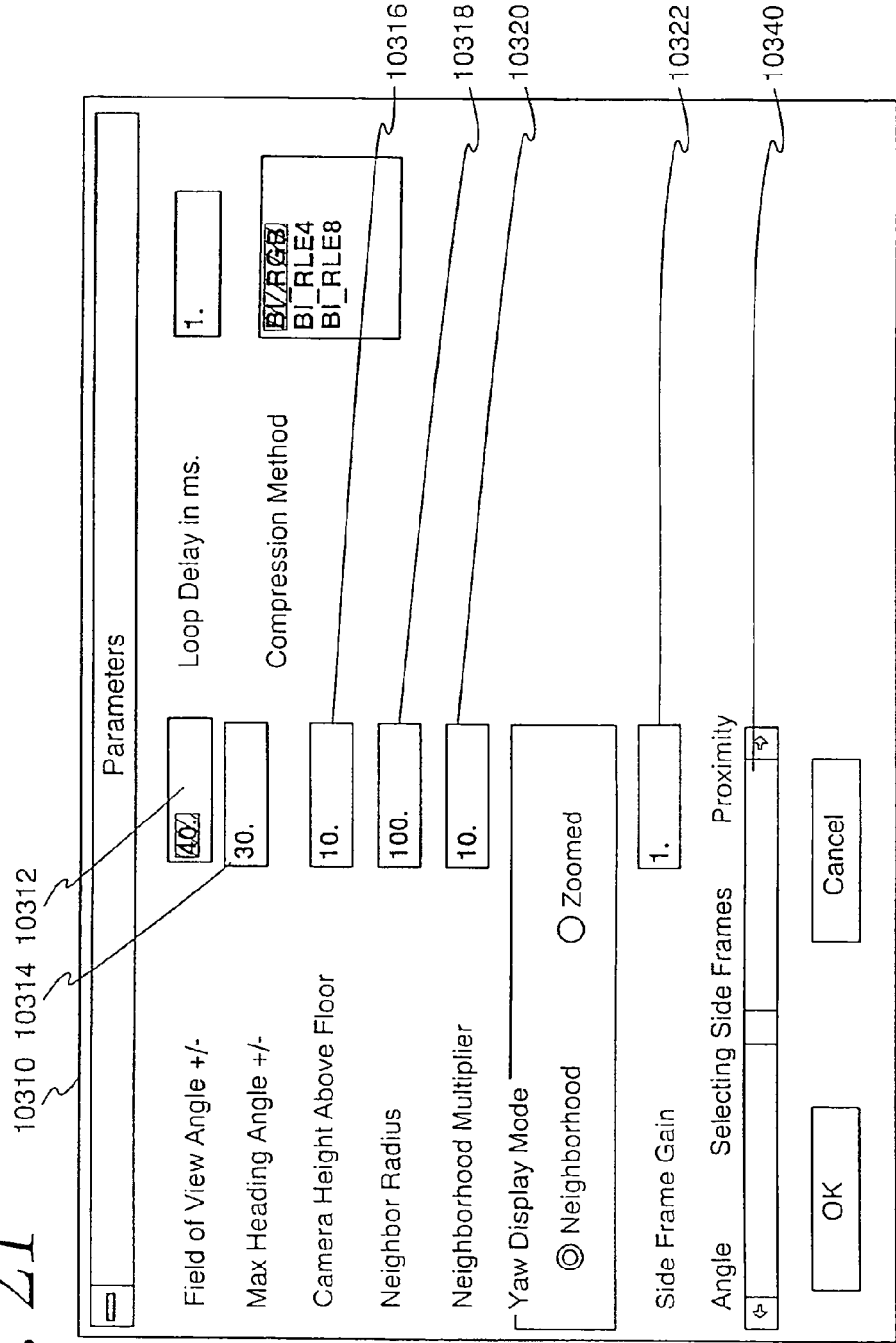

Fig. 22

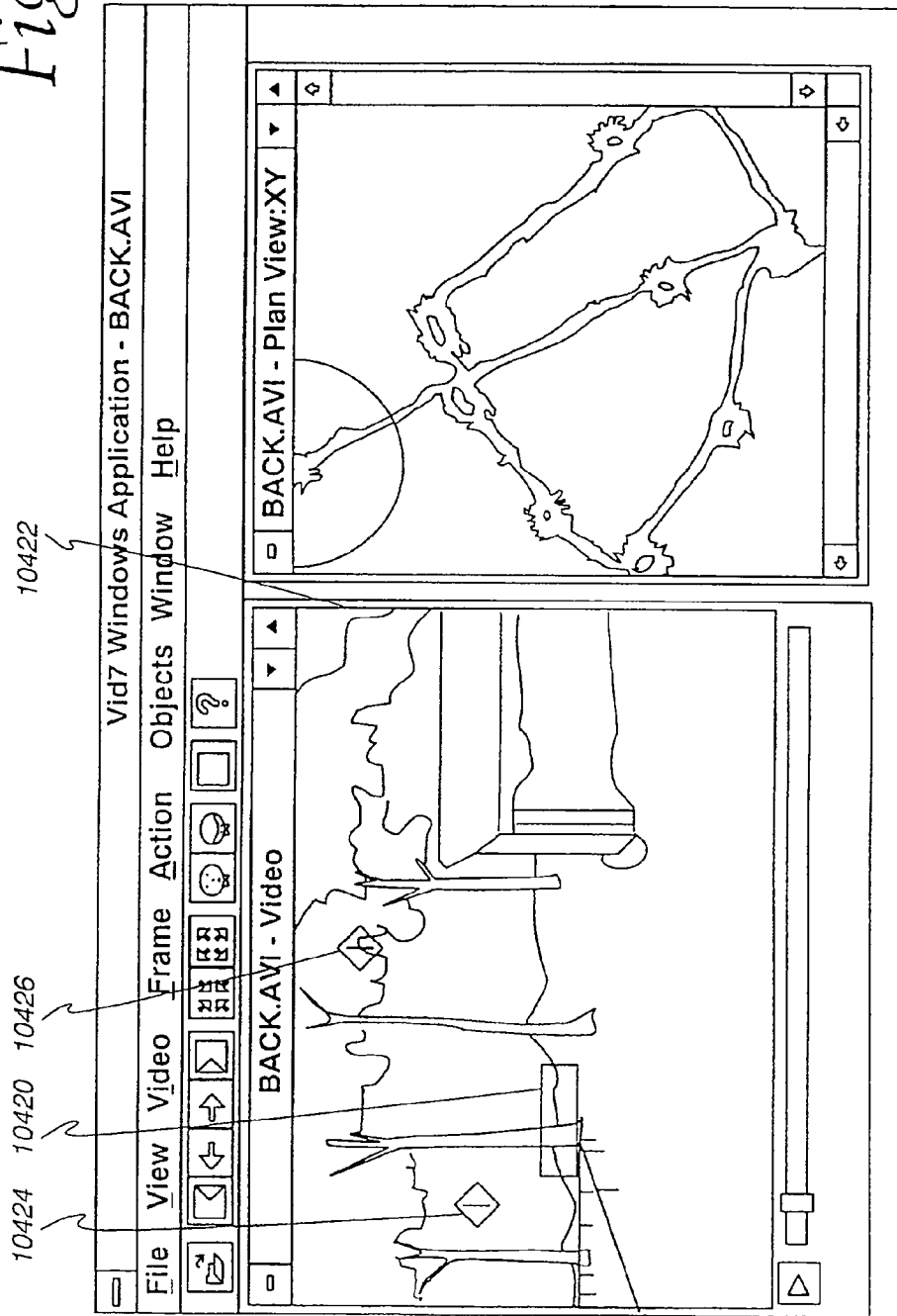

Fig. 23

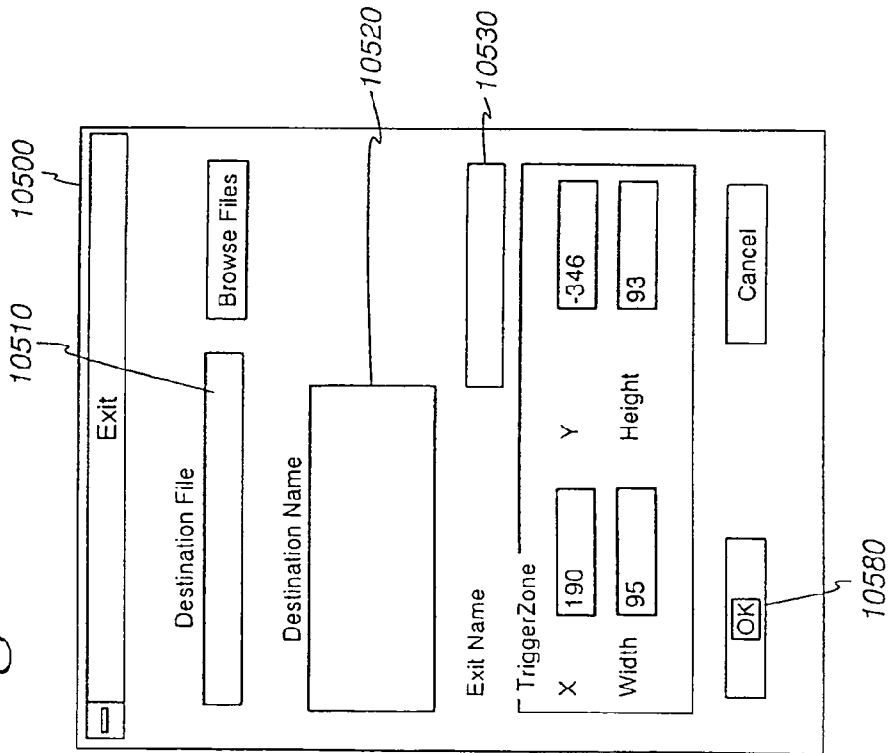

Fig. 24

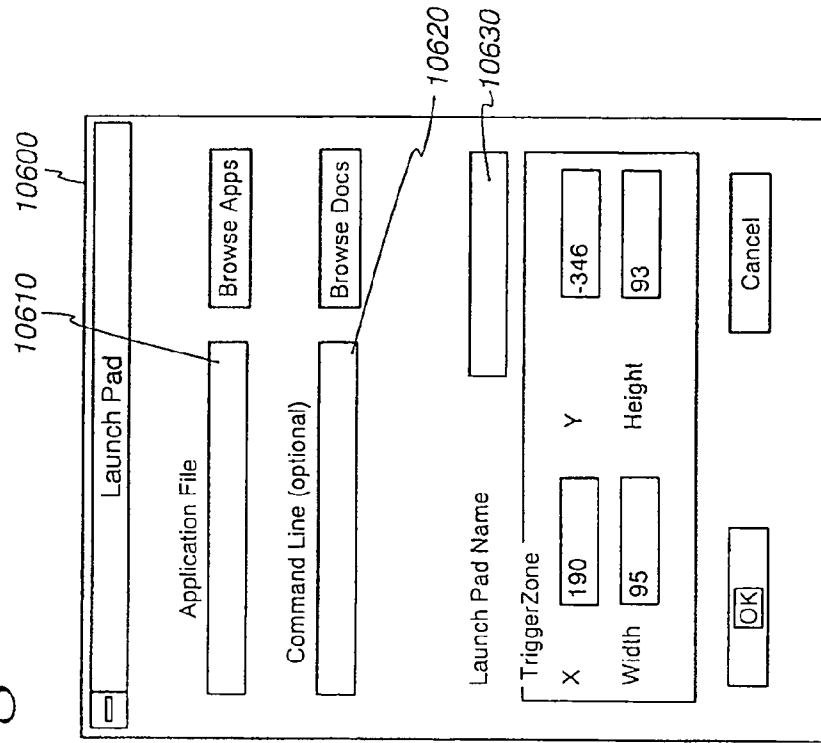
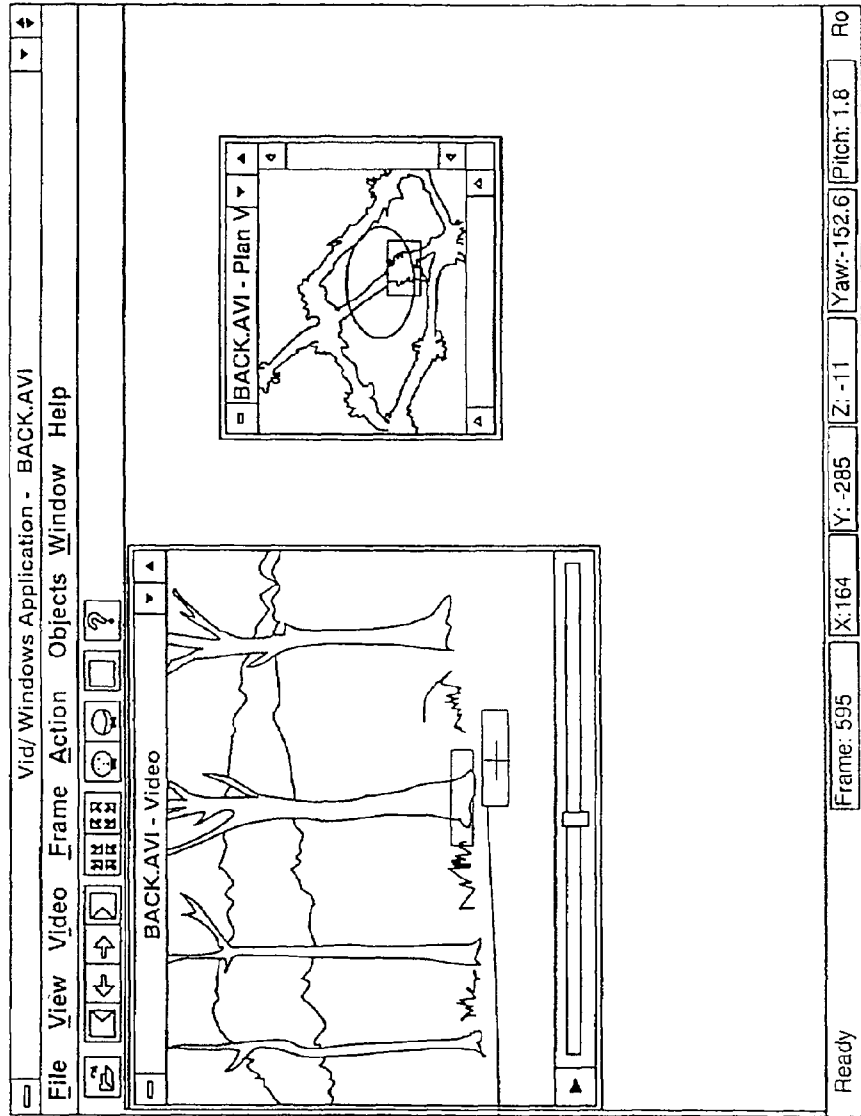

Fig. 25



10722

Fig. 26

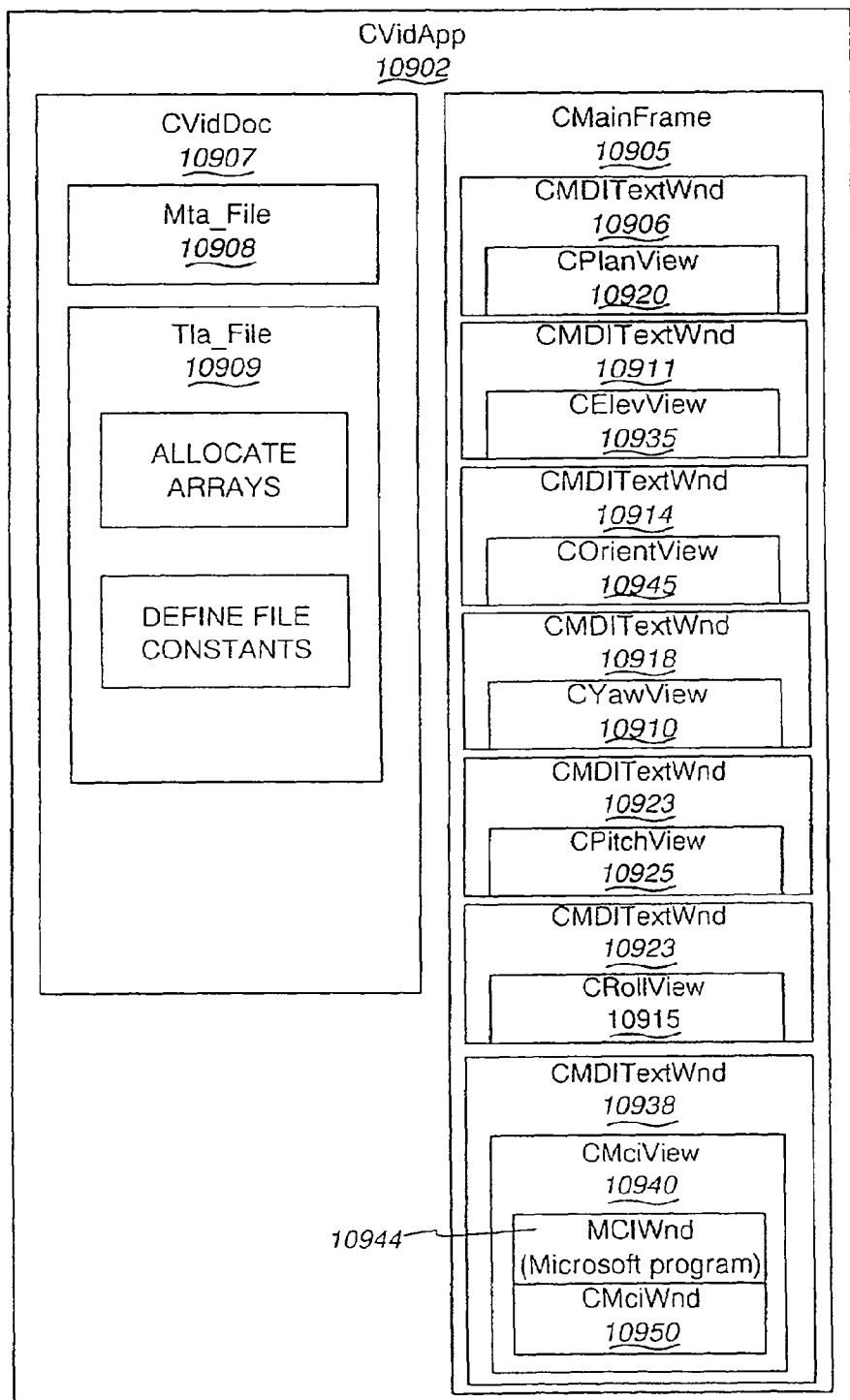

Fig. 27

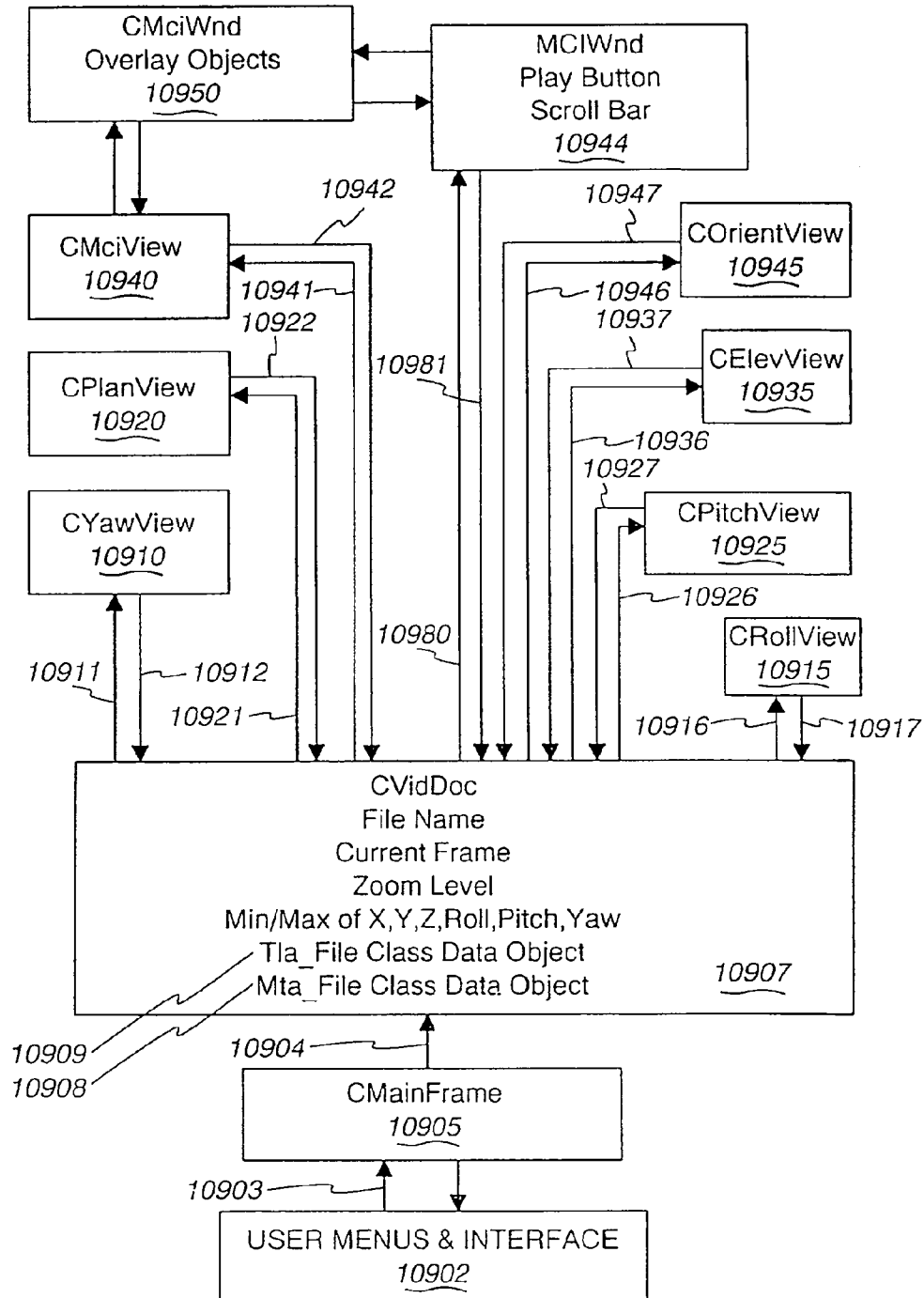

Fig. 28

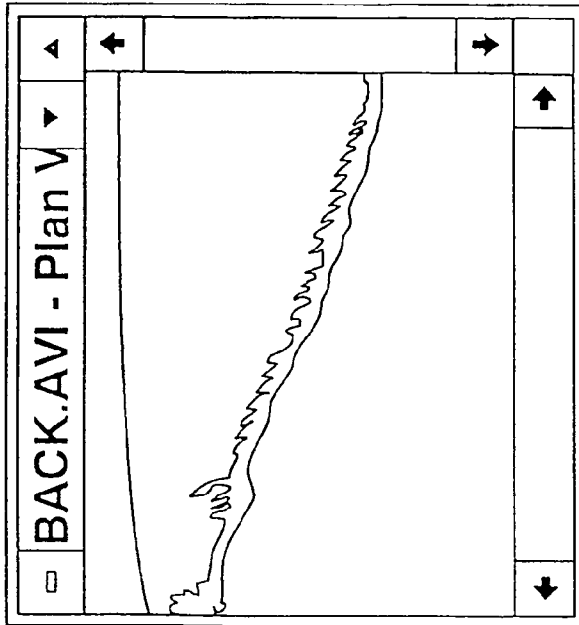

Fig. 29

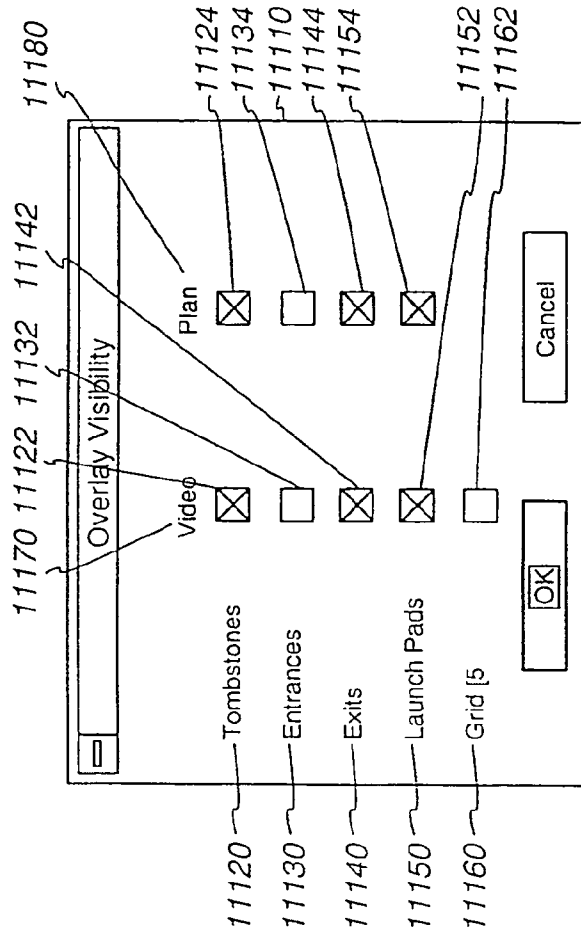

Fig. 30

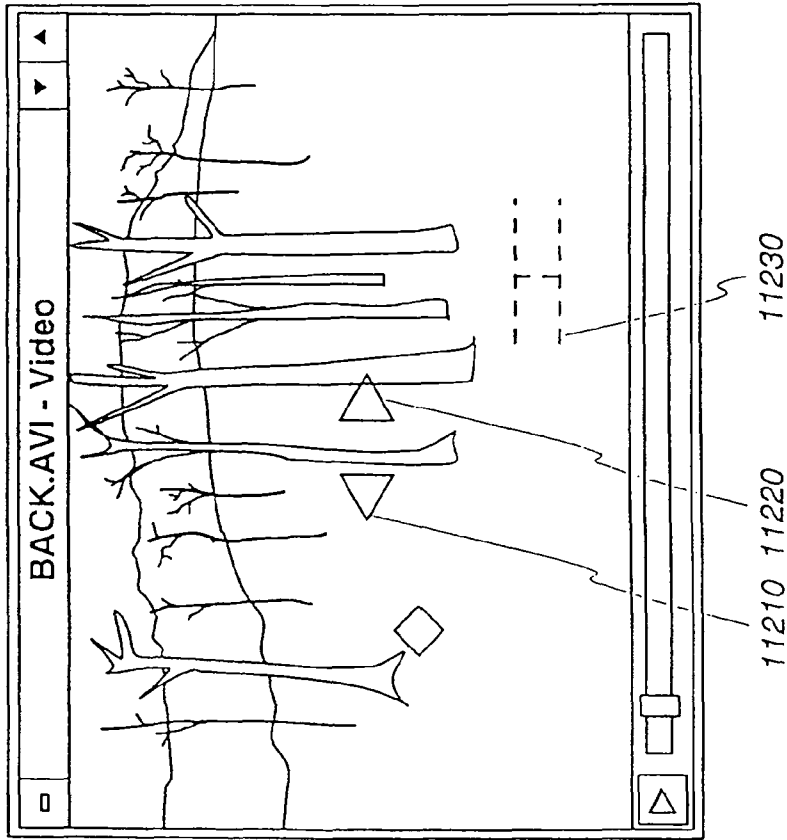

Fig. 31

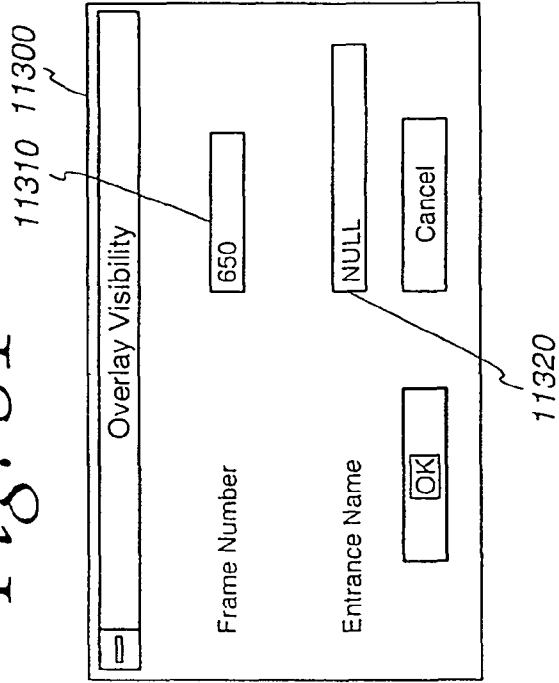

Fig. 32

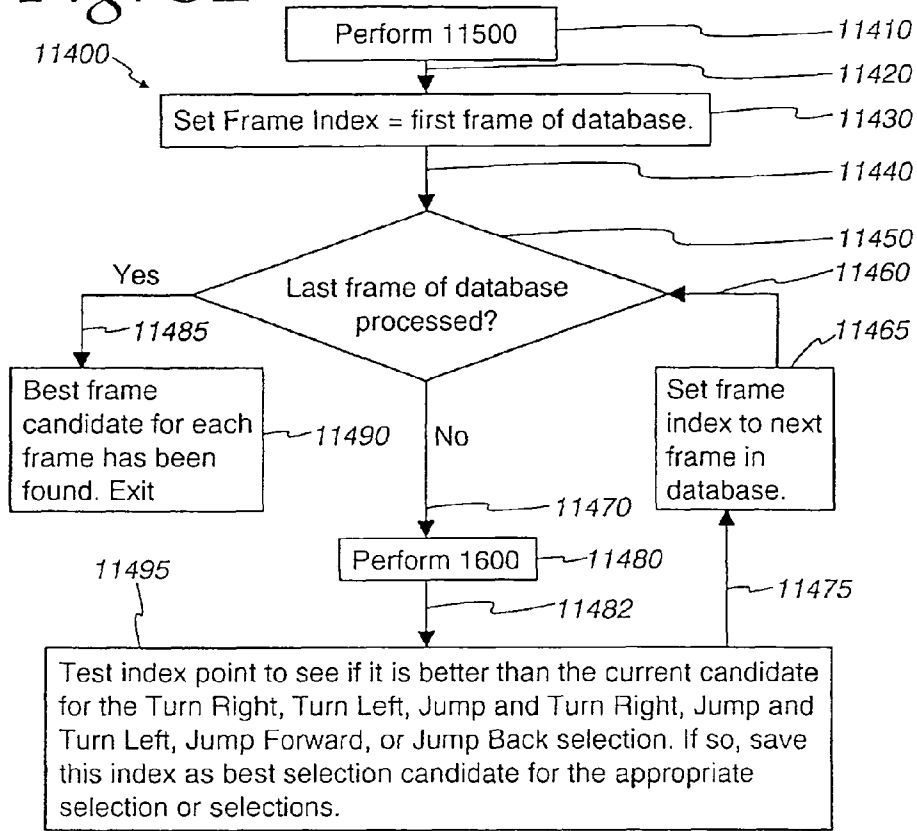

Fig. 33

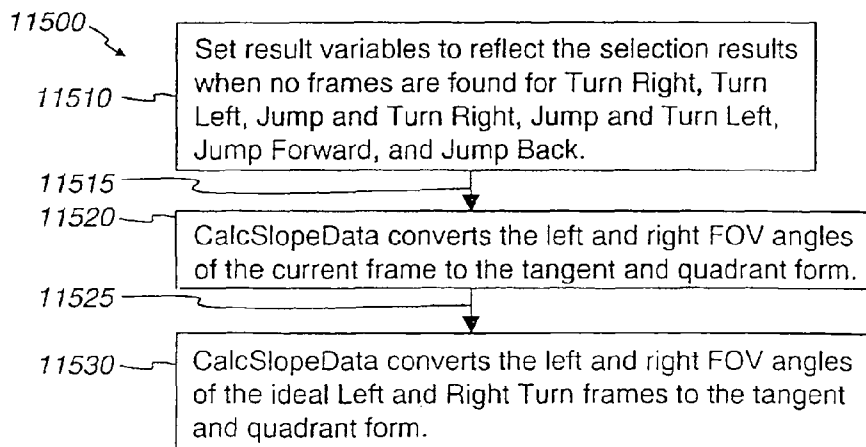

Fig. 34

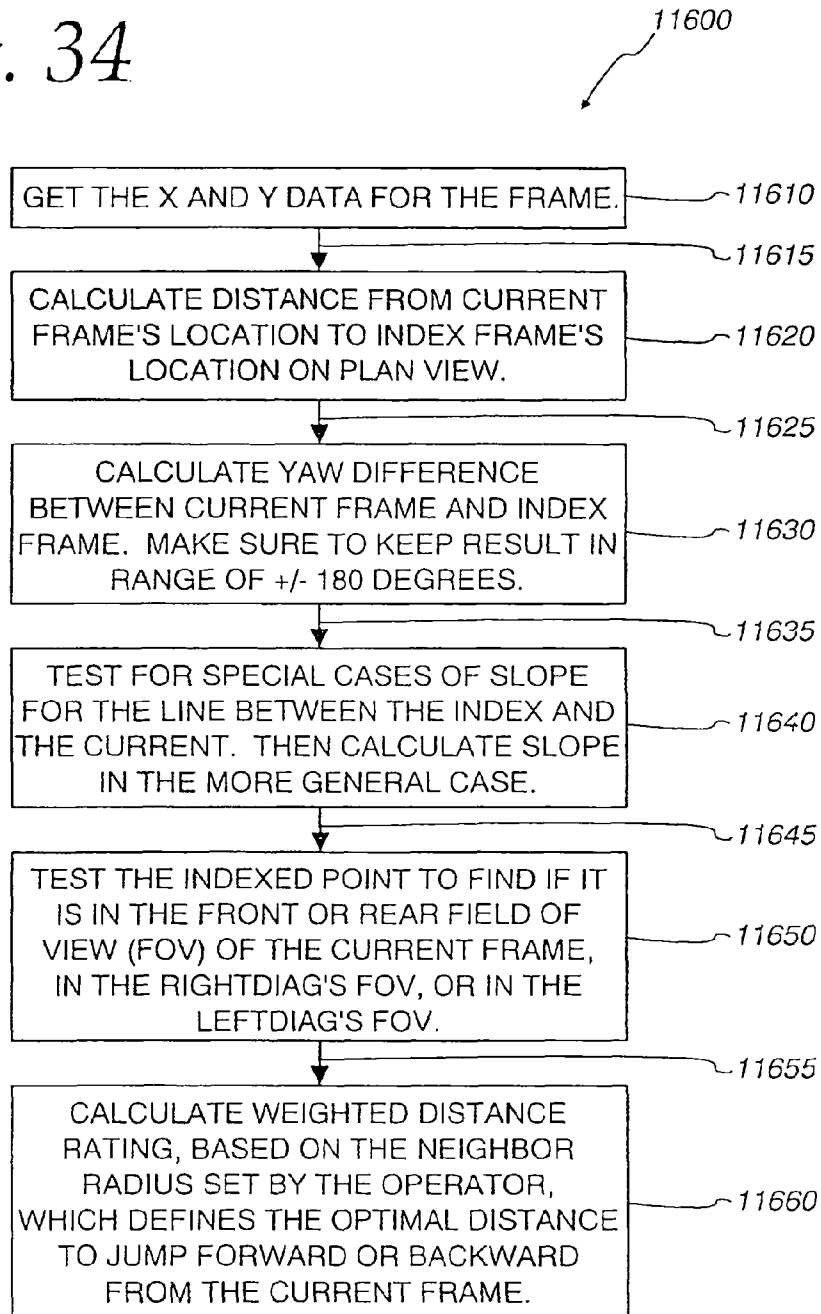
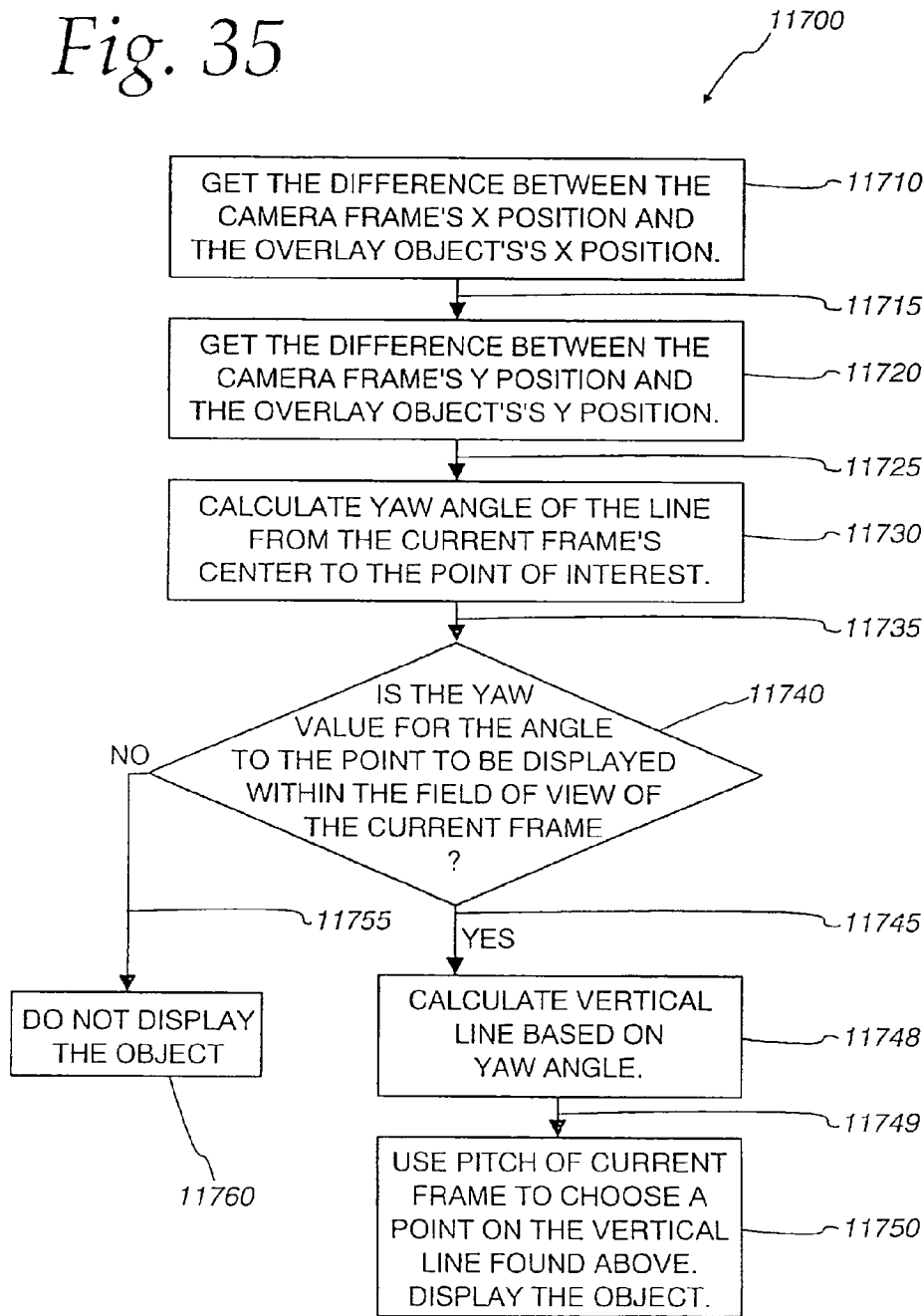

Fig. 35



**SPATIAL REFERENCED PHOTOGRAPHIC
SYSTEM WITH NAVIGATION
ARRANGEMENT**

Matter enclosed in heavy brackets [] appears in the original patent but forms no part of this reissue specification; matter printed in italics indicates the additions made by reissue.

CROSS-REFERENCE TO RELATED
APPLICATION

This application is a *continuation reissue application of reissue application Ser. No. 12/126,664, filed May 23, 2008, to be issued as U.S. Pat. No. Re. 42,289, which is a reissue application of application Ser. No. 09/723,767, filed Nov. 28, 2000, issued on May 23, 2006 as U.S. Pat. No. 7,050,102, which is a continuation application of application Ser. No. 08/894,206, filed Jul. 30, 1997, now U.S. Pat. No. 6,195,122, which is a 35 U.S.C. § 371 national stage U.S. application corresponding to Patent Cooperation Treaty application PCT/US96/01434, filed on Jan. 31, 1996, which is a continuation-in-part of U.S. patent application Ser. No. 08/383,471, filed on Jan. 31, 1995, which is hereby incorporated by reference. In particular, the '471 application contains a more detailed description of the tracking data acquisition unit control circuit 470 (in '471 application FIGS. 16 to 23 and the accompanying text) and exemplary program listings (presented in the Appendices of the '471 application) which may be of interest to those seeking a more detailed understanding of the present invention.*

FIELD OF THE INVENTION

This invention relates to referencing, sorting, and displaying images in a three-dimensional system. More particularly, it relates to a system having an image capturing device that captures images of objects together with spatial reference information defining the absolute position of the image capturing device and the relative position of the object relative to that device. It also relates to image retrieval and display, where the spatial reference information associated with each image facilitates browsing through the images in an organized manner.

BACKGROUND OF THE INVENTION

The editing of films and video images, i.e., to rearrange action sequences, is well known. However, the movie and video cameras used to capture the images that are later edited do not store with those images any machine-understandable record of image and camera position. Accordingly, the edited films and videos permit one to view the images in only one predetermined order, determined by the editor. If some other ordering of the image presentation is desired, it must be achieved through a difficult manual editing process.

A computerized, interactive editing process is described in a doctoral thesis "Cognitive Space in the Interactive Movie Map: An Investigation of Spatial Learning in Virtual Environments", by Robert Mohl, 1981, submitted at MIT. In a demonstration carried out using images recorded at Aspen, Colo., the viewer is permitted to select film clips taken by a camera that is arranged to simulate driving down a street. At each intersection, the viewer chooses to turn left, turn right, or to proceed straight ahead. The viewer thereby simulates driving around streets in Aspen, Colo.

In other fields, it is known to gather, along with images, information concerning the position of the camera. Governmental and private agencies use satellites and airplanes to record images of positionally referenced data, such as land features or clouds. Each image frame contains positional references to the image tilt or plane of the camera. Present methods commonly either constrain the orientation of the camera to a fixed position, i.e. up and down, or use features captured in the image frames to derive relative positions and orientations of successive images when combining the image frames to form a map or the like.

Devices are known which combine images by matching features common to each of two or more images, i.e. superimposing.

One aspect of the present invention is recording positional data along with images. A number of methods are known whereby one may locate an object and describe the position of an object relative to a positional reference. For example, a magnetic device is known which can determine its position and orientation within a known magnetic field. Satellite systems and radio signal triangulation can also be used to determine position precisely. Inertial position determination systems are also known and are widely used in inertial navigational systems.

An object of this invention is providing an image data gathering device which encodes positional and/or spatial information by capturing both camera position and camera orientation information along with image data. This information permits images to be joined or sequenced for viewing without the distortions that can result from attempting to match the edges of adjoining images together.

A further object of this invention is providing three-dimensional image reconstruction of objects using frames shot from different viewpoints and perspectives through the provision of a triangulation reference.

Still another object of this invention is providing a camera path map which allows images to be selected based upon the position and orientation of the camera from the map. For example, an operator can learn the location of an object in a film clip, such as an escalator. Images of the escalator may then be quickly and automatically located by selecting other frames which point to that same escalator from different camera positions.

Another object of the invention is providing a compact and practical image and positional data recording system which uses commonly available equipment. A system having accelerometers mounted directly upon the recorder, eliminating the need for a restrained or gimballed platform, permits greater freedom of motion for the recording device as well as reduced cost and complexity.

Briefly described, the invention resides in a video camera that is integrated with a tracking data acquisition unit containing accelerometers and gimbal-mounted gyroscopes, and optionally a rangefinder. As the operator of the video camera moves about taking a motion picture of the environment, a microprocessor and logic associated with the accelerometers and gyroscopes senses all rotational motions of the camera by means of sensors associated with the gimbals and senses all translational motions of the camera by means of sensors associated with the accelerometers. And the rangefinder provides information to the microprocessor and logic concerning the distance from the camera to the subject being photographed.

From data presented by these sensors, the microprocessor and logic compute and generate a modulated audio signal that is encoded with a continuous record of acceleration in the X, Y and Z directions as well as with a continuous record of the

pitch, roll, and yaw of the camera and of the distance to the subject. This audio tracking information data signal is recorded on the audio track of the same video tape upon which the video images are being recorded by the camera. In this manner, the video tape recording captures, along with the sequence of images, the tracking data from which the precise position of the camera, its precise orientation, and the position of the subject may later be computed.

Later on, the recorded audio tracking information data and video data is played back into a computer. Images are selected from the sequence of images and are retained, in compressed form, in a database. Each image is then linked to computed positional information that defines, for each image, the location and orientation of the camera and, optionally, the distance to the subject and the subject location. This positional information is derived through computation from the tracking information retrieved from the video tape audio track, as will be explained below.

Next, special computer programs can aid an individual using the computer in navigating through the images, using the positional information to organize the images in ways that make it easy for the user to browse through the images presented on the graphics screen. Several such programs are described below, and a complete description is presented of a movie mapper program which presents the user with a plan view and elevational views of the camera path plotted as a graph alongside views of selected images, with the path marked to show the position and orientation of the camera. The user, by clicking at any point on this path with a computer mouse, may instantly retrieve and view an image captured at the chosen point. Additionally, by clicking upon diamonds and arrows and the like displayed as overlays superimposed upon an image, the user may command the program to search for and find the nearest image which gives a view rotated slightly to the left or right or which maintains the same view but advances forward in the direction of the view or backward. One may also jump forward and turn simultaneously. A wider field of view may be assembled by assembling automatically chosen images and aligning them into a panorama. The user is thus enabled to navigate through the images in the manner of navigating a boat to the extent permitted by the nature and variety of the images in the data base.

Further objects and advantages are apparent in the drawings and in the detailed description which follows.

BRIEF DESCRIPTION OF THE DRAWINGS

FIG. 1 is a rendering of the spatially referenced video camera 100, which includes a tracking data acquisition unit and modulator 105, a video camera 120 having a video cassette recorder 130, a demodulation circuit 155, and a personal computer 185.

FIG. 2 is a perspective drawing of the tracking data acquisition unit and modulator 105.

FIG. 3 is a block diagram showing the tracking sensors and the microprocessor based tracking data acquisition unit control circuit 470 according to the invention in the context of the spatially referenced video camera 100.

FIG. 4 is a data format diagram showing the tracking data acquisition unit output packet format.

FIG. 5 is a block diagram of the program system modules that represent the major software components of the spatially referenced camera system.

FIG. 6 is a data flow diagram depicting the data flow through the tracking data acquisition unit and modulator 105.

FIG. 7 is a data flow diagram depicting the tracking and video data flow from playback of the video cassette recorder

130, through the demodulation circuit 155, into the personal computer 185 under the control of the data entry and storage program 305.

FIG. 8 is a data format diagram depicting alternative positional data record formats including the quaternion position notation record format 715 and the direct angular notation format 775.

FIG. 9 is a block diagram of the tracking database to positional database conversion program 310.

FIG. 10 is a more detailed block diagram of the step 10006 in FIG. 9.

FIG. 11 is a more detailed block diagram of the step 1120 in FIG. 10.

FIG. 12 is a more detailed block diagram of the calculate current position step 1214 in FIG. 11.

FIG. 13 is a block diagram of an alternative method for converting tracking data to position data.

FIG. 14 is a more detailed block diagram of the write position record step 1122 in FIG. 10.

FIG. 15 is a block diagram of the tracking data acquisition unit control circuit 470 illustrating in particular its electrical interconnections to the remaining elements of the spatially referenced video camera 100.

FIG. 16 is a block diagram of the programs which control the central processing unit 480 in FIG. 15.

FIG. 17 is an alternate embodiment of the invention illustrating use of the tracking data acquisition unit and modulator 105 as a pointing and image retrieval device.

FIG. 18 illustrates the operation of the positional frame retrieval program 330 in which range information is added so that all of the images viewing a selected object 3202 may be located and retrieved, as a group.

FIGS. 19 to 25 and 28 to 31 are computer screen snapshot views of the screens generated by the movie mapper program 325 in operation, including presentations of the captured images, of the path of the camera in plan and elevational views, and of various pop-down menus;

FIG. 26 is a block diagram illustrating the structure of program-generated objects in the movie mapper program 325 when it is in actual operation.

FIG. 27 is an information flow block diagram of the program-generated objects in the movie mapper program 325 illustrating how they communicate.

FIGS. 32 to 35 are flow chart representations of portions of the movie mapper program 325.

DETAILED DESCRIPTION OF THE PREFERRED EMBODIMENT

Referring to the drawings and especially to FIG. 1, a spatially referenced video camera is shown embodying the present invention and generally identified by the numeral 100. The spatially referenced video camera 100 includes a tracking data acquisition unit 105 rigidly attached to a video camera 120 having a built-in video cassette recorder 130. As the spatially referenced video camera 100 is operated, video data from the video camera 120 and tracking data from the tracking data acquisition unit 105 are recorded onto a video cassette within the recorder 130. Once the desired recordings have been made, the information is transferred to a personal computer 185 for processing and display.

FIG. 3 presents a block diagram of the camera 100, illustrating its individual hardware components and how they are interconnected by signal paths. The tracking data acquisition unit control circuit 470 contains a data acquisition program 300 (FIG. 16), and the personal computer 185 contains a number of computer programs. All of these programs, and

their data flow relationships, are shown in FIG. 5 which illustrates the camera 100's software components in overview.

With reference to FIG. 5, the video data gathered by the video camera 120 and the position and orientation data gathered by the tracking data acquisition unit and modulator 105 (under the control of the microcontroller data acquisition program 300) are first stored on videotape. Later, they are fed into the personal computer 185. The two data streams are captured by the tracking and video data entry and storage program 305 and are stored, respectively, in a tracking database 324 and in a video database 323.

Once safely stored within the personal computer 185, the tracking database 324 is reprocessed into a positional database 322 by a tracking database to positional database conversion program 310. Now the image retrieval programs 325, 330, and 335 may be called upon to search through the positional database 322, to retrieve images from the video database 323 based upon camera location, camera orientation, and even object location, and to display the images upon the face of the computer 185.

Tracing the data flow through the system components at a more detailed level will explain the functionality of the preferred embodiment of the spatially referenced camera.

First, the video camera 120 (FIG. 1) produces a standard video signal that is recorded on the video track of a video cassette by the camera's video cassette recorder 130. Referring to FIG. 2, the tracking data acquisition unit 105 contains three orthogonally positioned translational accelerometers 435, 440, and 445; two orthogonally arranged gyroscopes 400 and 410; and a laser rangefinder 485. All six of these sensors are rigidly mounted to an inertial platform 415. Referring to FIG. 3, a control circuit 470 polls the output signals of these sensors and assembles tracking data frames 535 (FIG. 4) which describe the instantaneous, real time orientation and translation acceleration experienced by the spatially referenced video camera 100. A serial bit stream comprised of these tracking data frames is modulated to produce an audio line level modulated tracking data signal 115 which is fed into the audio input 125 of the video cassette recorder 130 and recorded on the audio track of the video cassette alongside the corresponding video information.

Second, the completed recording, stored on the video cassette, is played back to the personal computer 185 on any standard video cassette player or directly from the camera 120 (FIG. 1). The tracking data is demodulated by a demodulator circuit 155 and is input to the personal computer 185 through a standard serial I/O serial port 175. Simultaneously, the video data is input to the personal computer 185 via a video digitizer input 180. Referring to FIG. 5, a data entry and storage program 305 stores the tracking and video data on the personal computer's disk operating system 320 in a tracking database 324 and in a video database 323. A second program 310 converts the tracking database 324 into a positional database 322.

Third, the set of three display programs 325, 330, and 335 allow a user to view and select video frames based on the relative position or absolute orientation of the camera.

Tracing the data flow through the individual parts of the spatially referenced video camera 100 at the most detailed level discloses how to build the preferred embodiment of the invention.

Referring to FIG. 3, the tracking data acquisition unit 105 continuously measures the translational acceleration and rotational orientation experienced by the spatially referenced video camera 100. To achieve the most accurate measurement of translational acceleration, three accelerometers 435, 440

and 445, such as SUNDSTRAND Model QA-700, are positioned orthogonal to each other and are mounted on a stable inertial platform 415. The accelerometers measure acceleration in each of three dimensions: accelerometer 435 measures acceleration in the X direction, accelerometer 445 measures acceleration in the Y direction, accelerometer 440 measures acceleration in the Z direction. Each accelerometer outputs a voltage signal with an amplitude proportional to the acceleration detected. A multichannel analog to digital converter 465, such as ANALOG DEVICES Model AD7716, receives each accelerometer's output and generates a 24-bit numerical representation of the acceleration experienced in each direction.

Two gyroscopes, such as GYRATION Model GE9100A, a vertical gyroscope 400 and a directional gyroscope 410 are also orthogonally mounted on the stable inertial platform 415 relative to each other. The vertical gyroscope 400, aligned along the X or Y axis, measures yaw (rotation about the Z axis), while the directional gyroscope 410, aligned along the Z axis, measures both roll (rotation about the Y axis) and pitch (rotation about the X axis). (The Y axis is assumed to point in the direction of the camera.) The gyroscopes are dual gimbaled electronic components that generate a pair of square wave signals which are locked out of phase with respect to each other. The sequence of the rising and falling edges of the square waves relative to each other indicates the angular rotation about the gyroscope's measurement axis experienced by the spatially referenced camera 100. Quadrature decoders 450, 455, 460, such as HEWLETT PACKARD Model HCTL2020, receive the three paired square wave signal outputs of the gyroscopes 400, 410; and for each signal pair, they count the relative sequence of rising and falling edges between the two square wave signals to generate a 16-bit numerical representation of the rotation experienced about each axis. An interrupt is generated following any change in these signals. This interrupt causes a central processing unit 480 (FIG. 15) within the tracking data acquisition unit 105 to capture the new status of the counts within the decoders 450, 455, and 460.

The inertial platform 415 (FIG. 2) is connected to a post 425 that is threaded at one end 430 such that the entire data acquisition unit 105 can be rigidly attached to the tripod mounting hardware of a standard camcorder 120.

In addition to the accelerometers and the gyroscopes there is a control circuit 470 (FIGS. 2, 3, and 15) mounted to the bottom of the inertial platform 415 (see FIG. 2). This microcontroller based circuit (Z-WORLD SMARTBLOCK Model SB-DEV-32) polls the quadrature decoders 450, 455, 460 and the analog to digital converter 465 in sequence. Referring to FIGS. 4 and 6, the respective data packets 500, 505, and 520 from each sensor and a frame identification pattern (530 or 550) are compiled to form the tracking data frame 535 (or 540) as the first step 600 (FIG. 6) in the data flow through the spatially referenced video camera 100. In the next few steps, 605, 610, 615, and 620, the data frame resulting from the first step 600 is broken into 4-bit nibbles which are encased within message byte having a "1" start bit and three "0" stop bits, as in "1XXXX000" where "XXXX" is the 4 bits of data. The message bytes are then subjected to encoding (HARRIS Model HD-6409). The control circuit transmits a continuous stream of the tracking data frames to a modulator circuit 475 (FIGS. 3 and 15) that modulates the data on to an audio line level signal. The inertial platform 415, the circuitry 420, the gyroscopes 400, 410 and the accelerometers 435, 440, 445 are all contained within a case 107 (FIG. 1). The single output 110 from the case 107 produces an audio signal 115 containing the encoded bit stream of acceleration and orientation data. The output of the tracking data acquisition control cir-

cuit 470 is thus recorded to video tape alongside the corresponding video data signal from the video camera 120.

The spatially referenced camera 100 can be configured and used with a laser rangefinder 485 (FIG. 2), such as an Acuity Research Inc. ACCURANGE Model 3000 in addition to the video camera 120. In this configuration, the instantaneous distance between the spatially referenced camera 100 and a pinpointed location on the surface of an object that is being recorded is also captured and stored as a binary numerical representation of distance along with tracking data from the other sensors. As shown in FIG. 4 at 540, range data derived from the rangefinder 485 is appended to the data frame and recorded to video tape alongside the corresponding video data signal from the video camera 120. (If the camera 120 is of an "autofocus" design, it may be possible to derive a range signal from the camera's autofocus mechanism.)

The rangefinder 485 (FIG. 2) is rigidly mounted to the inertial platform 415 and generates a continuous serial data output signal containing two alternating values. The rangefinder 485 output signal RXA1 is directly input to the tracking data acquisition unit control circuit 470 as a serial data signal. The first value contained in the signal output by the rangefinder 485 is a 24 bit numerical representation of the distance between the precise spot on the surface of the object being recorded and the spatially referenced camera 100. The second value is an 8 bit gray scale value that indicates the reflectivity of the object's surface at the measured location. In this configuration, the control circuit 470 is configured to be interrupted by a signal from the quadrature decoders 450, 455, & 460 whenever there is a change in the inertial platform's orientation detected by the gyroscopes 400 and 410. Upon detecting an interrupt signal, the control circuit reads the range and reflectivity values presented serially by the rangefinder 485. In this alternative configuration, a range data packet 520 (FIG. 4) is compiled along with the accelerometer data packets 500 and the gyroscope data packets 505 to form the tracking data frame with range data as indicated at 540 in FIG. 4.

Referring to FIG. 4, the tracking data frame format 535 output by the tracking data acquisition unit 105 is essentially comprised of two or three different kinds of packets: acceleration packets 500, gyroscopic packets 505 and optionally, range packets 510. An acceleration packet 500 is a 24 bit value that represents the magnitude of an acceleration vector in the X, Y or Z direction. A gyroscopic packet 505 is a 16 bit value that represents degree of pitch, roll or yaw. A range packet 520 is a 24 bit value plus an eight bit value. The 24 bit value 510 represents a range distance and the eight bit number 515 represents relative surface reflectivity in terms of a gray scale value.

The format of a complete data frame 535 (without range information) is composed of a frame identification pattern 530, which is formed from three repetitions of the 16 bit value 017F hex (at 525). This is followed by data: a 24-bit acceleration value in the X direction 500A, a 16-bit pitch value 505A, a 24-bit acceleration value in the v direction 500B, a 16-bit roll value 505B, a 24-bit acceleration value in the Z direction 500C, and a 16-bit yaw value 505C. The tracking data frame format with range information included 540 starts with a frame identification pattern 550 composed of three repetitions of the value 037F hex (at 545), followed by a 24-bit acceleration value in the X direction 500A, an 8-bit delta (or incremental change) pitch value 505A, a 24-bit acceleration value in the Y direction 500B, an 8-bit delta roll value 505B, a 24-bit acceleration value in the Z direction 500C, an 8-bit delta yaw value 505C, and finally the range data 555 and a gray scale reflectivity value 560. The records

540 containing range information are generated whenever an interrupt from the decoders 450, 455, and 460 indicates that the camera orientation has changed.

Once the video tape is filled with modulated tracking and video data, it is played back. The video output is directly connected to a conventional video digitizer input 180, such as the INTEL SMART VIDEO RECORDER, that is inserted into the ISA, EISA, VESA, PCI, or other accessory port or slot of the personal computer 185. As the video cassette is played back on the video cassette player 130, the video digitizer input 180 captures the video frames of the recorded images and passes digitized video frame data on to the tracking and video data entry and storage program 305 shown in FIG. 7. The audio output of the video cassette recorder 135 is fed into a demodulator circuit 155 which converts the modulated tracking data signal back into a serial bit-stream of tracking data. The demodulation output 165 is connected to a conventional serial data input port 175 of the personal computer 185. As the video cassette is played back on the video cassette recorder 130, the demodulation circuit 155 converts the modulated tracking data signal into an RS-232 serial data signal which is read into the personal computer 185 by the tracking and video data entry and storage program 305 through the serial port 175.

FIG. 7 shows the tracking and video data entry and storage program 305 data flow diagram. The modulated tracking data signal 145 from the audio output 135 of the video cassette recorder 130 or is fed into the demodulator 155, where the audio signal is demodulated into a serial bit stream (step 640). The output of this process flows into a manchester decoder (step 645). Every other nibble following an initial leading one of the decoded bit stream is then serially transmitted by the demodulator circuit 155 to the personal computer's serial port 175 (step 650). In the next step 655, the personal computer receives the bit stream and encodes each nibble as a ASCII hex digit 655. The ASCII digits are then assembled into lines of tracking data 660.

Simultaneously, the video signal 150 from the video output 140 of the video cassette recorder 130 is captured (step 680), and video frames are selected (step 685). Frame numbers are assigned to the selected video frames (step 690), and at step 665 these frame numbers are concatenated to the lines of tracking data to form tracking data lines. Finally, at step 675 a database of numbered tracking data lines is created and is stored on the disk in a database file called the tracking database 324.

At step 695, the video frame is fed into a video compression program, and the outputted compressed video frame is concatenated or otherwise linked to the same video frame number at 695. Finally, at step 700, a database of numbered and compressed video frames is created and is stored on the disk in a file that is called the video database 323.

The tracking and video data entry and storage program 305, residing on the personal computer 185, essentially builds two related databases. The first is a tracking database 324 composed of enumerated records containing the orientation, the translational acceleration, and optionally the range data originally generated by the tracking data acquisition unit 105. The second is a video database 323 composed of enumerated records containing digitized and compressed images of video frames captured from the video tape originally generated by the video camera 120.

Once all of the recorded tracking and video data are stored, the personal computer 185 converts the tracking database 324 into a positional database 322 via a software module called the tracking database to positional database conversion program 310 (FIGS. 5 and 9).

In the preferred embodiment, an existing image capture computer program is adapted for use to capture, compress, and store selected images in the video database 323, as indicated in steps 680, 685, 690, 695, and 700 of FIG. 7. This is a conventional program for video capture that can capture and store a video image every $\frac{1}{10}$ th or $\frac{1}{20}$ th of a second or so (whatever the human user of the system specifies). This program is also capable of linking to and calling as a subroutine a separate program which performs the steps 655, 660, 665, 670, and 675 in FIG. 7 every $\frac{1}{10}$ th or $\frac{1}{20}$ th of a second, passing to this separate program the index value into the video database 323 that can later be used to find and retrieve the most recently captured image. This index value is stored in the tracking database 324 along with the associated tracking data extracted from the signal 170.

To implement the step 655, the computer 185 is equipped with a conventional, serial port interrupt driven program that is called upon automatically, whenever the serial input port 176 receives a serial byte of the tracking data signal 170, to retrieve the byte from the serial port UART and to store the byte in some form of circular buffer in RAM from which the bytes may be readily retrieved.

Each time the step 660 is performed (every $\frac{1}{10}$ th or $\frac{1}{20}$ th of a second or so), all the bytes currently in this circular buffer are retrieved, combined with historical data, and separated from any partial data frame that is retained as historical data. In this manner, several data frames in the format illustrated at 535 or 540 in FIG. 4 are retrieved from the circular buffer, combined with the current image retrieval index supplied by the image capture computer program, and stored in the tracking database 324 (FIG. 5). Note that even though not all of the video image frames are normally retained, every piece of tracking data information must be retained so that the position and orientation of the inertial platform can be computed by a "dead reckoning" process. Accordingly, the same video image number is typically combined with several sets of tracking data information.

FIG. 5 illustrates the creation of the positional database. Numbered tracking data frames from the tracking database 324 are input to the program 310 which, using well known principles of Newtonian mechanics, converts the tracking data lines into positional data records. The positional data records are stored to the disk in a database file called the positional database 322. The format of the positional data records is dependent upon the method of conversion used in the conversion program 310. As shown in FIG. 8, there are two possible formats for the equivalent positional data. The quaternion position notation record format is composed of position number 720, video frame number 730, X displacement from the origin 735, Y displacement from the origin 740, Z displacement from the origin 745, and a unit vector defined by an X component 755, a Y component 760, a Z component 770 and a twist component 750. This data completely defines the position and orientation of the spatially referenced video camera 100 with respect to the point of origin. The other equivalent format is the direct angular notation representation. It is composed of the position number 720, video frame number 730, X displacement from the origin 735, Y displacement from the origin 740, Z displacement from the origin 745, and angular coordinates Rx 780, Ry 785 and Rz 790. These numeric values are separated by space characters 725, as shown.

The details of the tracking database to positional database conversion programs 310 are shown in FIG. 9.

The program 310 begins at 1002 by initializing the variables. Then at 1004, it opens the input tracking data file 324 (FIG. 5), the output position file 322 (FIG. 5), and an alter-

ative output position file (not shown—this alternative file has the orientation represented in quaternion form, rather than as yaw, pitch, and roll values). At 1006, the data is retrieved, processed, and placed in the output file.

The data processing steps 1006 are described in FIG. 10.

The program steps 1006 control the reading of the input file and enforce the formatting of the output file. In particular, these steps buffer the position records in such a manner that each record processed is complete even though the input records may have been broken up, as described above. In this manner, the program generates one and only one output position record for each frame.

The program begins at 1110 by reading in a data frame. At 1114, if there are no more frames, then at 1130 the files are closed and we are done. If a frame is found, a data record is retrieved from the frame at 1112. At 1118, if a record is found, it is processed at 1120 and written out to the positional database 322 at step 1122. Whether or not a record is found, program control continues at step 1124 where any unprocessed residual data is prepared (or added to) the next frame. Program control then returns to 1110 where the next frame is read.

The data record processing routine 1120 is described in FIG. 11. First at 1210, a record is read and is corrected for gyro counter overflow. Since the pitch, roll, and yaw numbers are 16-bit numbers that increase continuously if the camera rotates, they will occasionally overflow to zero. These numbers are thus converted into a 32 bit numeric format that never overflows.

Next, the acceleration values are converted into a floating point form at step 1212. Gain and offset errors can be corrected in this step. This routine also computes the magnitude of the acceleration as the square root of the sum of the squares of the three components.

Step 1214 calculates the current position from the acceleration data. With reference to FIG. 12, first we test the magnitude to see if it is close to the gravitational constant (step 1310). If so, and if this is the first time that this condition has been met (step 1312), then the current yaw reading is saved as the zero directional reference for the data. In any case, at 1316, the gravity acceleration vector is used as a vertical reference for the purpose of determining how tilted the camera platform is. Values of pitch and roll, P0 and RV, are computed which, when applied to the camera's present pitch and roll, give a level reference platform. The program that performs this calculation is set forth below.

In the following short program, the values of acceleration are "ac->p.f" for the y value of acceleration and "ac->p.l" for the X value of acceleration (the z value is not needed). This program computes P0 and R0, and it acquires the initial yaw value as W0.

```

55 // acquire reference for pitch and roll gyros. Used to
// correct for G later
void GetRollPitchZero (PositionAttitudeRecord * ac,
                        long double magnitude)
{
    long double xmag, ymag, numAvg;
    xmag=ac->p.f/magnitude;
    ymag=ac->p.l/magnitude;
    numAvg=GO; // for backward average of all samples
    // numAvg=1; // for no averaging
    rref = -asinl (ymag);
    pref = asinl (xmag);
    // average over all samples, equal weights for all
    p0 = ((p0 * (numAvg-1)) + (deg(pref)+ac->a.p))/numAvg;
    r0 = ((r0 * (numAvg-1)) + (deg(rref)+ac->a.r))/numAvg;

```

-continued

```

if (GO == 1) // this one is the first
{
    w0 = ac -> a.w; // init to current yaw count
}
}

```

Acquisition of rØ and pØ values allows the definition of a reference frame for integration in which the transformed X and Y acceleration components have no contribution from the gravitational force. X and Y in the reference frame are perpendicular to the direction of the gravity vector, while Z in the reference frame is parallel to the gravity vector.

GetRollPitchZero also averages PØ and RØ readings on all subsequent calls after the first call to achieve better and better estimates for these values.

At step 1320, since the only acceleration is that of gravity, we assume that the camera is motionless, and we arbitrarily set the velocity values in all three directions to zero. This assumption holds because the camera is hand-held and is never stable when the human carrier is in motion. If the camera were mounted upon some conveyance that can move very smoothly at a uniform velocity, then this assumption would not hold, and some additional data indicating the velocity of the camera would have to be recorded. In an airplane or automobile, for example, the speedometer reading or ground speed reading could be recorded to assume that this algorithm functions properly.

Next, at step 1318, the current pitch, yaw, and roll are transformed into coordinates that indicate these parameters relative to the newly-defined reference frame. This step 1318 is always performed regardless of whether the magnitude of the acceleration matches that of gravity.

To facilitate, the following computations, the yaw, pitch, and roll values, which are presently referenced to a horizontal plane, must be converted into what is called the quaternion form. This is a four dimensional vector with three imaginary components and one real component. This is done to facilitate the transformation of the acceleration values, which are presently referenced to the tilted camera plane, into values referenced to the horizontal reference plane (just defined, preparatory to integrating the acceleration values to produce velocity and displacement values.

This calculation is performed by the following program. In this program, the input variable is a record "AttitudeRecord" which contains yaw "w", pitch "p", and roll "r". The returned quaternion values are "s", "i", "j", and "k", where "s" is the real value and the others are the imaginary values.

```

// convert yaw,pitch,roll to quaternion form
void AttitudeQuaternion (AttitudeRecord * p,
    QuaternionRecord * qcos)
{
    long double cw,cp,cr,sw,sp,sr; /* sine and cosine */
    long double rp, rw, rr;
    long double trace, c[3][3];
    rw=rad(p->w);
    rp=rad(p->p);
    rr=rad(p->r);
    cw=cosl (rw);
    cp=cosl (rp);
    cr=cosl (rr);
    sw=sinl (rw);
    sp=sinl (rp);
    sr=sinl (rr);
// use cosine matrix form for calculation
c[0][0]=cw*cp; c[0][1]=sw*cp; c[0][2]=-sp;

```

-continued

```

c[1][0]=(-cr*sw) + (sr*sp*cp); c[1][1]=(cr*cp)*(sr*sp*sw);
c[1][2]=sr*cp;
c[2][0]=(sr*sw) + (cr*sp*cp); c[2][1]=(-sr*cp)+(cr*sp*sw);
5 c[2][2]=cr*cp;
trace=c[0][0] + c[1][1] + c[2][2];
qcos->s=sqrt(1+trace)/2.;
qcos->i=(c[1][2] - c[2][1])/(4.* qcos->s);
qcos->j=(c[2][0] - c[0][2])/(4.* qcos->s);
10 qcos->k=(c[0][1] - c[1][0])/(4.* qcos->s);

```

At step 1324, the acceleration vector is transformed from the camera body coordinate frame into the stable reference frame.

```

//rotate accel vector to platform coordinates
15 //using inverse quaternion
posqInverse.q.s=posqFwd.q.s;
posqInverse.q.i=-posqFwd.q.i;
posqInverse.q.j=-posqFwd.q.j;
20 posqInverse.q.k=-posqFwd.q.k;
QuaternionRotate (&pos->p,&posqInverse.q,&prec);
In the above, the acceleration vector is represented by a three
component vector "&pos->p". The four element quaternion
value (computed above) is "posqFwd.q.s", "-.i", "-.j", and
25 "-.k". In the above routine, this quaternion value is first
inverted, giving "posqInverse.q.s", etc. Next, this inverted
quaternion and the acceleration vector are passed to the
"QuaternionRotate" routine which returns the transformed
acceleration values in a vector "&prec".

```

At step 1326, the integration of the transformed acceleration values is carried out as follows:

```

dx+=(prec.l)/G;
dz+=(prec.u)/G;
35 dy+=(prec.f)/G;
x+=dx;
y+=dy;
z+=dz.

```

In the above routine, "dx", "dy", and "dz" are the velocity values in the x, y, and z directions. "x", "y", and "z" are the distance values. The incoming acceleration values are "prec.l" for the "x" axis acceleration, "prec.f" for the "y" axis acceleration, and "prec.u" for the "z" axis acceleration. Note that the acceleration values are normalized with respect to the value of gravity.

The quaternion coordinate transformation process is carried out by using two cross multiplications, and is illustrated below:

```

50 //returns rotated vector in rp
void QuaternionRotate (positionRecord *v,
    QuaternionRecord *q,
    PositionRecord *rp)
{
    QuaternionRecord vq,qi,rq;
55 // quaternion multiplication qi v q
// from the book.
// qi is -i -j -k...
vq.s=0; vq.i=v->f; vq.j=v->l; vq.k=v->u;
qi.s=q->s;
qi.i=-q->i;
60 qi.j=-q->j;
qi.k=-q->k;
QuaternionMultiply (&qi, &vq, &rq);
QuaternionMultiply (&rq, q, &vq); //reissue vq
rp->f=vq.i;
rp->l=vq.j;
65 rp->u=vq.k.

```

The incoming arguments to this function are a three-dimensional vector "v" that is to be rotated and a four-dimensional quaternion vector "q" that defines the rotation. The three-dimensional vector "v" is first transformed into a four-dimensional vector "vq" with the fourth component "vq.s" set to zero.

First, an inverse "qi" is formed of the quaternion "q". Next, the incoming vector "vq" is quaternion multiplied by the inverse quaternion vector "qi". The result of this multiplication "rq" is then quaternion multiplied by the quaternion vector "q". Three components of the resulting vector, which is returned as "vq", are transferred back into the vector "rp" which is returned as the transformed result.

The quaternion multiplication is defined by the following program: void QuaternionMultiply (QuaternionRecord *q, QuaternionRecord *s, QuaternionRecord *r)

```

{
  r->s=(q->s*s->s)-(q->i*s->i)-(q->j*s->j)-(q->k*s->k);
  r->i=(q->s*s->i)+(q->i*s->s)+(q->j*s->k)-(q->k*s->j);
  r->j=(q->s*s->j)-(q->i*s->k)+(q->j*s->s)+(q->k*s->i);
  r->k=(q->s*s->k)+(q->i*s->j)-(q->j*s->i)+(q->k*s->s);
}

```

The details of the step 1122 in FIG. 10 relating to the writing out of a record 775 (FIG. 8) are set forth in FIG. 14. At step 1402, if any frame numbers were skipped, at step 1122 a position record is generated and saved for each such skipped frame. Since there are more acceleration records than there are video frames, step 1408 tests to see if the current frame number has already been written out as a position record. If not, then a new position record 775 is written out at step 1410 along with the frame number. In any case, at step 1412, the position record is saved for possible future use if any frames were skipped (at step 1402 during a future iteration).

In addition to writing out the records 775 (FIG. 8) into the positional database 322 having the file name extension "*.TLA", the preferred embodiment of the invention simultaneously writes out records of the type 715 (FIG. 8) into a separate positional database (not shown) having the file name extension "*.TEL". In this manner, two positional databases are created, one specifying camera attitude using the direct angular notation format, and the other specifying camera attitude using the quaternion notation format.

An alternative method of position estimation using the inertial platform is now described. The accelerometer inputs described above as the vector "pos" in the program "acc2pos.c" is replaced by a vector of constant velocity as shown in this program fragment:

```

if (magnitude < G + DELTA_MAG//+DELTA
    && magnitude > G - DELTA_MAG//+DELTA
    )
{
  // for velocity estimation method
  // dx = dy = dz = 0;
  pos->p.f=0;
}
else
{
  pos->p.f=500; // assume motion is in direction
              // camera is pointing
}
pos->p.l=0; pos->p.u=0;

```

This sets the velocity vector to one of two values, depending upon the magnitude of instantaneous acceleration being experienced. The vector component "pos->p.f" is the component pointing in the direction of the camera.

If the magnitude is below the threshold G+ or -DELTA_MAG (the force of gravity plus or minus a small deviation, determined by empirical measurement), the camera is assumed to be at rest. If the magnitude is outside this range the velocity is set to be the average velocity of a person walking. The camera is pointed in the direction the operator is walking whenever the operator moves, and this velocity vector is transformed using, the same quaternion as the acceleration measurement above.

The velocity vector is rotated in the following code fragment:

```

QuaternionRotate(&pos->p.&posqInverse.q.&prec);
The position is then calculated by summing each resultant component:
x-=prec.l;
y+=prec.f;
z+=prec.u;

```

The full text of the alternative "acc2pos.c" file is given in Appendix F. This file is to be substituted for the "acc2pos.c" file listed in Appendix B.

FIG. 13 shows the flow diagram for the alternate position calculation method. FIG. 13 is to be substituted for FIG. 12 in the program flow described above. In particular, the box in FIG. 12 labeled 1324 is replaced by a box 3380, and the box labeled 1326 is replaced by a box 3390.

In FIG. 13 box 3340 the absolute value of acceleration magnitude is compared to that of gravity plus a constant value. If the absolute value of the difference of these quantities is greater than zero, movement is indicated. The forward velocity component pos->p.f is then set to a velocity value of "walking speed" in box 3350. Otherwise forward component is set to 0 in box 3360. In either case the left-right and up-down components are set to 0 in box 3370.

The velocity estimate is then transformed from platform coordinates to reference coordinates in box 3380. The resulting transformed velocity is summed component-wise to produce the position estimate in box 3390.

These boxes in FIG. 13 are identical to their counterparts in FIG. 12:

- FIG. 13 box 3310 is identical to FIG. 12 box 1310.
- FIG. 13 box 3312 is identical to FIG. 12 box 1312.
- FIG. 13 box 3314 is identical to FIG. 12 box 1314.
- FIG. 13 box 3322 is identical to FIG. 12 box 1322.

Referring now to FIG. 15, the hardware circuitry portions of the invention are shown in block diagram form. FIG. 15 sets forth all of the significant signal interconnections between the circuitry blocks.

As shown in FIG. 15, the heart of the tracking data acquisition unit 105 is a control circuit 470 which contains a central processing unit 480. This central processing unit, in the preferred embodiment, is a Z-WORLD SMART BLOCK, Model SB-DEV-32, programmable computer.

In FIG. 15, the central processing unit 480 provides addressing signals 1502, data signals 1504, and control signals 1506 to a control logic 490. The control logic 490 contains two programmable logic units PALS which respond to the signal from the CPU by generating all of the various control signals that are needed to run the tracking data acquisition unit 105.

The rangefinder 485 is shown connected to the CPU 480 by means of two serial communication lines, an outgoing serial communication line TXA1 carrying commands from the CPU 480 to the rangefinder 485, and a return serial commu-

nication line RXA1 carrying serial information from the rangefinder **485** back to the CPU **480**. The rangefinder **485** returns gathered information periodically, at its own rate of speed. The CPU **480** formulates a range packet **520** (FIG. 4) containing a 24 byte range value **510** and an 8 byte gray scale value **515**, and adds it to the telemetry stream of data.

The two gyroscopes, the directional gyroscope **400** and the vertical gyroscope **410**, are designed so that when they are deprived of power, they return to rest positions with the vertical gyroscope **410** having its axis vertically disposed and with the directional gyroscope **400** having axis horizontally disposed.

When the camera **100** is placed into operation, the central processing unit **480** causes the control logic **490** to generate a GYRON signal and to feed it to a gyroscope regulated power supply **420**. In response, the gyroscope power supply **420** generates a plus 10 volt, regulated +GYRO signal which feeds power to both of the gyroscopes **400** and **410**. In response, the gyroscope motors begin to spin so their axis are stabilized and so that the gimbals associated with the gyroscopes begin to generate pairs of quadrature modulated signals indicating the rotational motions of the tracking data acquisition unit **105**.

The directional gyroscope **400** generates two square wave signals in quadrature as the platform **415** is rotated about a vertical axis to the left or to the right. These quadrature signals, which may be called collectively the yaw signal, appear on the two wires DOA and DOB. These signals arise from sensors associated with the gimbals within the gyroscope **400** in response to rotation of the gimbals.

The vertical gyroscope **410** is similarly equipped with two sets of sensors associated with its gimbals to generate pitch and roll quadrature modulated signals. The pitch signal, which appears on the two wires V1A and V1B, indicates the rate at which the camera **100** is pointing more upwards towards the ceiling or more downwards towards the floor. The roll, signal which appears on two wires V0A and V0B, indicates the rate at which the camera is tilting to one side or to the other, away from or towards the vertical.

These quadrature modulated pairs of signals require brief explanation. Assume for the moment that the camera is being rotated horizontally from left to right. This will cause a yaw signal to appear on the two wires D0A and D0B. Each wire bears a square wave signal, and the square waves are at quadrature with each other. This means that a negative going transition of the first of the square wave signals is followed by a negative going transition of the second of the square wave signals. Likewise, a positive going transition of the first signal is always followed by a positive going transition of the second signal. The speed of these transitions indicates the speed with which the camera is being rotated from left to right. If the camera motion stops, then the signals remain stationary until camera motion proceeds once again.

If the direction of rotation is reversed, then again square wave signals are generated—but this time in the opposite phase of quadrature. Thus, if a left-to-right motion causes a first signal to make its transitions ahead of the second signal, then a right-to-left motion will cause the second signal to make its transitions ahead of the first signal. This is identical to the way in which the motion signals work in a mouse pointing device of the type commonly used with digital computers.

The pitch and roll signals, represented respectively by the V1A-V1B and by the V0A-V0B signal lines, operate in a manner identical to the yaw signal just described, with the information being conveyed by quadrature modulated square waves. The three pairs of quadrature modulated signals V1A,

V1B, V0A, V0B, and D0A, D1B are fed into respective quadrature decoders **450**, **455** and **460**. The quadrature decoders **450**, **455** and **460** are conventional models, in this case Hewlett Packard Model No. HCTL 2020. The three accelerometers **435**, **440**, and **445** are shown each generating an analog accelerometer output signal SIG0, SIG1, and SIG2 and also a temperature signal TEMP0, TEMP1, and TEMP2. These signals flow into the multiplexer and A-to-D converter **465**.

In the manner described above, the central processing unit **480** is enabled to obtain data indicating the distance of the subject from the rangefinder **485**; it is enabled to obtain pitch, roll, and yaw data values from the vertical and directional gyroscopes **400** and **410**; and it is enabled to obtain data defining the instantaneous acceleration of the tracking data acquisition unit **105** from the accelerometers **435**, **440** and **445** in all three coordinate directions. The CPU **480** continuously packages this information, as explained in steps **600** to **615** in FIG. 6, into the frame data format that is illustrated at **535** or **550** in FIG. 4. This frame data format information is presented in parallel, one byte at a time, over the data bus D0-D6 to shift register and encoder **475**.

The shift register and encoder **475** converts the signal into a modulated serial tracking data signal which is presented over the audio data line **115** to the audio record input **125** of the VCR **130**.

To summarize the operation of the tracking data acquisition unit **105** as shown in FIG. 15, the central processing unit retrieves from the rangefinder **485** in serial form an 8 bit gray scale value **515** and a 24 bit range value **510**, as shown in **520** in FIG. 4. It retrieves from the quadrature decoders **450**, **455**, and **460** associated with the directional and vertical gyroscopes **400** and **410** 16 bit data values representing the current pitch, roll, and yaw as stored within counters within the quadrature decoders **450**, **455** and **460**. It retrieves from the X, Y, and Z accelerometers **435**, **445**, and **440**, 24-bit values representing the current instantaneous acceleration to which the tracking and data acquisition unit **105** is being subjected.

It then combines all of this information into a packet, with each byte in the packet containing a "1" start bit, a nibble of data, and three trailing "0" stop bits, with a 3 byte header **530** and **550** such as those shown at **535** or **540** in FIG. 4. Each packet thus begins with the frame ID pattern elements shown at **525** or **545** as three bytes of information. This is followed by the X acceleration data **500A**, the pitch data **505A**, the Y acceleration data **500B**, the roll data **505B**, the Z acceleration data **500C**, the yaw data **505C**, the range data **555**, and the gray scale data **560**, as shown in FIG. 4. This information is sent through to the shift register and encoder **475** and appears as a modulated tracking data signal on the audio line **115** which is then recorded by the VCR **130** along with the images flowing from the video camera **120**.

Upon playback, the video signal **150** flows directly into the personal computer **185**. The modulated tracking data signal **145** flows to a demodulator **155**. Following demodulation, the unmodulated tracking data signal flows over a signal line **170** to the PC **185**.

FIG. 16 presents a block diagram view of the three programs that control the operation of the central processing unit **480** shown in FIG. 15. Two of these programs **2402** and **2404** are interrupt driven, and the third program **2406** either runs continuously, or it is called into operation periodically by a timer triggered interrupt or other similar mechanism.

The program **2406** begins at **2408** by initializing the system. Initialization includes such steps as turning on the power supply **420** for the gyroscopes, programming and initializing

the three quadrature decoders **450**, **455**, and **460**, and setting up the analog to digital converter (within the block **465** in FIG. **15**).

Next, at **2050**, data is gathered from the rangefinder **485**. At **2052**, the analog to digital converter is commanded to gather from the accelerometers **435**, **445**, and **440** the current acceleration of the tracking data acquisition unit **105**.

At step **2054**, the above data, together with previously stored values of yaw, roll, and pitch are combined into a data packet, with 4 bits of data per byte, as has been explained above (steps **600**, **605**, **610**, and **615** in FIG. **6**; and see the data formats presented in FIG. **4**).

At step **2056**, the resulting data packet is placed into RAM memory as a series of bytes to await transmission to the shift register and encoder **475**.

At step **2058**, the interrupt driven program **2402** is placed into service to transmit the bytes of data to the shift register and encoder **475**.

At step **2060**, the program **2406** tests to see if all of the data bytes have been transmitted. Alternatively, the program simply suspends itself until a fixed time interval has expired. In either case, after transmission is completed or after the expiration of the time interval, program control recommences with step **2050**.

The program **2406** thus continuously operates to assemble data packets and to transmit them to the shift register and encoder **475** where the data is modulated onto an audio signal suitable for recordation on the audio soundtrack of a VCR.

The program **2402** is an interrupt driven program placed into operation by the interrupt signal INT1 every time the shift register and encoder **475** successfully transmits a byte of information. At **2062**, this program simply sends a data byte from RAM to the shift register and encoder **475** until there are no more data bytes that remain to be transmitted. This interrupt driven routine frees up the program **2406** from the time consuming task of continuously monitoring for when to transmit the next byte of data.

The program **2404** is also an interrupt driven program. It is placed into operation every time one of the three quadrature decoders receives a signal fluctuation from one of the gyroscopes. In response to INT2, this program gathers pitch, roll, and yaw values from the two gyroscopes and stores them in RAM for later transmission at step **2064**.

Three display programs are available for viewing the information stored in the positional database.

The spatial database program **335** (FIG. **5**) is controlled by a three-dimensional navigation tool, such as the SUN COM FLIGHT MAX JOY STICK, or any three-dimensional, commercially available game control device. Each frame is displayed, and the user is asked whether he wants to select it. A database of frames selected for display is created. For each frame, a two-dimensional rectangle of fixed size is drawn using the WORLD TOOL KIT in a perspective view of three-dimensional space. The rectangle is displayed in the simulation space in the orientation specified by the attitude of the camera positional frame record that corresponds to the video frame. The rectangle is then textured with the video frame so the frames appear to float in space before the user.

The movie mapper program **325** is described in detail below.

The positional frame retrieval program **330** allows the user to identify a region in space on the camera path using the WORLD TOOLKIT. The program defines a rectangular solid in space about each imaged object. The location of each item imaged is computed from the data in each record. All the image records where the location of the item image falls outside of the rectangular solid for an item are discarded, and

all remaining records are displayed as a movie view of the item from different perspectives. In essence, all available frames showing the item or the volume indicated are displayed sequentially, giving all the views available of the desired item or volume.

The data tracking and acquisition unit and modulator **105** has illustratively been shown connected to a rangefinder, receiving therefrom a serial data signal which is conveyed to the central computer for possible use in a data retrieval system. The positional frame retrieval program **330** uses this range data to determine the position of imaged objects and to retrieve all images containing a designated object, as contrasted with the movie mapper program technique of retrieving images based upon camera position and orientation (described below).

For example, in FIG. **18**, an object **3202** is shown within a camera path **3204** along which the camera orientation at the moment of image capture is indicated by vectors **3206**. In FIG. **18**, the vectors shown connected by dotted lines **3208** to the object **3202** represent the capture of an image of the object **3202**. Range information is also captured indicating how far the object **3202** is from the camera at each of these points.

The range data is preserved in the positional database **322** for this embodiment of the invention. Accordingly, the retrieval program **330**, in response to a mouse click at the position of the object, may locate all records **775** which, from position, camera angle, and distance to subject, relate to images of that object. These may be grouped into an object database and displayed as a video movie, as described above.

In addition to a rangefinder, other devices may be attached to the serial data input of the tracking data acquisition unit and modulator **105**, and data may be captured from these other devices. For example, data may be captured from a gas chromatograph or from a chemical sniffer. Sound may be recorded from a microphone. Average light intensity may be recorded from a photo cell. Infrared records of motion in the vicinity may be recorded. Data may be gathered from stationary machinery or data collection devices, such as flow meters or temperature sensors. Any type of data that has a spatial reference may be gathered in this manner.

Another embodiment of the invention is shown in FIG. **17**. The computer **185** contains a positional database **322** established previously, in accordance with the teachings set forth above. The positional frame retrieval program **330** is actively retrieving images from the databases **322** and displaying them.

In this embodiment, the tracking data acquisition unit and modulator **105** is not attached to the camera, but is attached by a serial communicator tether **3102** (which could include a radio linkage) directly to the serial port of the computer **185**, such that the tracking and video data entry and storage program continuously accepts the data and stores it in the tracking database **324**. The tracking data acquisition unit is thus enabled to be used as a mouse pointing device for the positional frame retrieval program **330** to guide in the retrieval and display of images—an inertial joystick.

The tracking database **324** may be on the hard disk as previously, but preferably it is a RAM circular buffer that is shared by the tracking database to positional database conversion program **310**. Alternatively, the tracking data values may be sent as messages between the two programs running under Windows and subject to the standard Windows message dispatcher (not shown). Both of the programs **305** and **310** can be simplified, since neither is dealing with video or with frame numbers in this embodiment.

The tracking database to positional database conversion program operates continuously, receiving tracking data con-

taining unnormalized acceleration and orientation data and converting it into normalized position and orientation data, and sending the resulting data directly to the positional frame retrieval program 330, thereby causing the program 330 to update the display continuously in response to manual movement of the tracking data acquisition unit and modulator 105 through time and space.

As an alternative, two computers can be utilized. A first portable computer (not shown) can be attached to the tracking data acquisition unit and modulator 105 can contain the program elements 305, 324, 310 and 330, shown in FIG. 17. This computer continuously computes the coordinates and position of itself in time and space and broadcasts this information by means of a radio LAN or serial port, for example, to a stationary computer that contains the positional database 322. The stationary computer broadcasts back the database information to the portable computer, where it is displayed. In this manner, a virtual world can be created where the one carrying around the portable computer can view a universe that exists in virtual form on the disk and that was recorded earlier at this or some other location.

As a third alternative, the tracking data acquisition unit and modulator 105 in FIG. 17 can be equipped with a video monitor receiving video signals from the computer 185 (by television transmission over a radio link, for example). Then one may wander about with the television and tracking data acquisition unit viewing a virtual reality derived from the positional database 322.

The arrangement illustrated in FIG. 17 can also be used as a three-dimensional pointing device for programs other than the positional frame retrieval program. Any kind of three-dimensional software program requiring the assistance of a navigation tool having either three or six degrees of freedom may be readily modified to accept the positional data records generated at 3104 by the tracking data acquisition unit and modulator 105.

Another embodiment of the invention utilizes a movie mapper 325 (FIGS. 19 to 35) to assist the user in retrieving and displaying the images. The program structure, defined by a series of nested objects, is depicted in overview in FIG. 26. The dynamics of event message transmission between objects is depicted in FIG. 27, and the most important data structures are in accordance with previously-described FIGS. 5 and 8. The operation of the program, as seen by the user, the window dynamics, and the program resources are depicted in FIGS. 34 to 40 and 43 to 46, which disclose a series of operating states and menus of the program.

The program 325 is written in Microsoft C++ to run under Microsoft Windows, Version 3.1. Some of the programs call upon routines contained within the Microsoft Video For Windows Development Kit, Version 1.1. All of the above may be obtained from Microsoft Corporation, 1 Microsoft Way, Redmond, Wash. 98052. The Media Control Interface "MCI-Wind" 10944 (FIG. 26) from the Video For Windows package is used to control the scrolling through the playback of video images within the AVI (audio video interleave) video child window, MCIView 10940, described below. Many of the array processing routines presented within the program file TLA_FILE, as well as the vector, array, and tensor allocation programs are taken from the book Numerical Recipes in C, 2nd Edition, by Press, Vetterling, Teukolsky, Flannery (Cambridge University Press, 1992) and from the program diskette that accompanies this book. (These routines have been placed in the public domain by the authors of the book).

With reference to FIGS. 19 to 26, and beginning with FIG. 19, when the user turns on the movie mapper 325, a main frame window 10100 opens up. The user first actuates the File

popdown menu and calls for the display of an AVI file (a Microsoft Audio Video Interleave file). These files, in the present version of the invention, have file names with the suffix ".AVI". In all respects, these files correspond to all of Microsoft's specifications.

The program 325 opens up the selected "*.AVI" file. It also looks for and attempts to open a telemetry file, containing the positional information, which has the same name and the file name suffix "*.TLA". The "*.TLA" file must be prepared for this program by adding to the beginning of the file a single line of text. The line is "HDR<tab><last frame number>" where <tab> is the tab character, and <last frame number> is the first number on the last line of the file. If no "*.TLA" file is found, the system issues an error message but permits one to browse through the "*.AVI" file in the normal Microsoft manner. The program also looks for and attempts to open an "*.MTA" file for its own use in defining overlay characteristics. An empty "*.MTA" file should be supplied, since the program will issue an error message and quit if none is found. The File popdown menu contains the usual list of Microsoft options, including Open AVI, Print, Print Preview, Print Setup, Exit, and a numbered list of recently opened AVI files to facilitate recalling a file recently opened.

The figures illustrate what happens when an AVI file BACK.AVI and its corresponding telemetry file BACK.TLA were successfully opened. Upon opening this file, the program 325 causes a Video child window 10110 to be opened, displaying in this case a view of the back yard of a private home. This video window is labelled at the top with "BLACK.AVI—Video" to identify both the file and the fact that this is the child window. The child window 10110 provides controls that are standard Microsoft controls for scrolling through a sequence of video images. These include a VCR-like control 10108. Clicking on this control starts the video playback if it is stopped, and stops it if it is running. The control is marked with a square when the video is playing, and it is marked with a triangle (shown) when the video is stopped. The Video popdown menu contains selections for changing the size of the video window to the original size, half the original size, or double the original size. A mouse-actuated slider control 10103 (FIG. 19) permits the user to position the video playback to any frame of the temporal video sequence. All of these functions are provided by Microsoft's utilities.

A View pulldown menu permits additional child windows to be opened that relate to the position information. The View menu provides the following options, which are described below:

- Triple MCI
- Plan
- Elevation
- Yaw
- Pitch
- Roll
- Orientation
- Overlay Visibility
- Toolbar
- Status

Actuating the Plan command causes a plan view: XY child window 10120 to open up, displaying the path 10123 over which the camera was moved during the process of recording the sequential images. This window is labeled: "BACK.AVI—Plan View: XY" to identify the file name as well as the nature of the view. While not clearly visible in FIG. 19, a large red dot 10128 identifies the precise position along the path 10123 where the camera was positioned when it recorded the image shown in the view window 10110. Smaller red dots

10126 and **10127** identify side frames which are shown to the left and right of the main frame when the "Triple Mci" View menu item is selected. Dark green dots show the field of view (fov) of the camera **10129**, giving an indication of the direction the camera is pointing. When the "Play" button **10108** is pushed to commence a sequential playback of images, a series of red dots (again not clearly shown in FIG. 19) indicate the camera's track. These red dots are spaced apart to produce a dotted line effect following the path of the camera as it moves along the path in the X and Y directions. The color of the remaining points along the track is blue.

Activating the Elevation command causes an Elevational View: XZ child window **10130** to open up, displaying the camera path of movement as seen from the side, rather than from the top. The display in all other respects is identical to the plan view display just described.

Activating the Yaw command causes a Yaw View child window **10140** to open up, displaying the various yaw directions the camera assumed during the image recording process. Yaw may be thought of as compass direction.

Likewise, activating the Pitch command causes a Pitch View child window **10150** to open up, displaying pitch directions in a fashion analogous to the Yaw View above. Pitch is inclination of the camera in the vertical image plane, that is looking up and down. In this example, the images do not vary significantly in pitch.

Activating the Roll command opens a Roll View child window **10160**, displaying roll directions as above. Roll is the tilt of the image plane from side to side, or leaning.

By clicking twice upon a point on the camera path in any of the child windows **10120**, **10130**, **10140**, **10150**, or **10160**, the user may signal the program to switch to displaying the image closest to the point where the mouse pointer was clicked and having the desired position, angle, or orientation. This selection process provides a rapid method for retrieving and positioning the video for playback based upon the desired position of the camera when an image was captured.

Activating the Orientation View command causes a child window **10180** to open up, displaying the orientation of the camera (pitch, roll, and yaw) graphically. Unfortunately, the absence of colors in FIG. 19 makes the figure less than clear. The positive Y direction is indicated by the line **10181**, with the negative Y direction indicated by the line **10182**. Note that the line **10181** indicating positive Y is Bold, to serve as a reference line. The positive X direction is indicated by the line **10185**, and negative X is indicated by the line **10186**, the positive Z direction is indicated by the line **10188**, and the negative Z direction is indicated by the line **10187**.

The actual direction of the camera, when it captured the image shown in the child window **10110**, is indicated by the line **10183**, which appears half in red and half in blue in the actual program display (and does not match the bold black line **10189**). The dotted line **10184** is a projection of the camera direction line **10183** onto the X-Y plane. As a sequence of images is displayed in response to actuation of the play control **10108**, the red-blue line **10183** swings about, indicating the orientation of the camera, and the dotted line **10184** swings about below (or above) the line **10183** like a shadow at noontime on the equator.

Roll is represented by the ratio of blue and red portions of the line **10183**. If the roll value is zero, then the line is half red and half blue. Roll in a clockwise direction increases the blue, while roll in a counterclockwise direction increases the red. A positive roll gives more red.

A toolbar containing push button controls (**10141**, **10142**, etc.) appears in the window **10101** and may be selectively displayed or hidden by actuating the Toolbar command in the

View pulldown menu. The push button **10141** is an alternate way to open a file. The push buttons **10142** and **10145** respectively wind to the first and the last frames, and the push buttons **10143** and **10144** respectively move back and forward by one frame at a time.

The push button **10146** zooms in, and the push button **10147** zooms out. These two push buttons control the portion of the video path that is displayed by the Plan View and Elevational View child windows **10120** and **10130**, and the orientations shown in the Yaw View, the Pitch View, and the Roll View. To zoom in, and with reference to FIG. 19, the user uses the mouse to position the cursor and then, with the left mouse button held down, drags the cursor diagonally so that a mouse-defined rectangle **10122** is created within the child window **10120**. The user then clicks the zoom in push button **10146**. The Plan View: XY window's contents are then replaced by the contents of the marked rectangle, expanded out to fill the window (FIG. 28). The ElevView: XZ window's X axis is simultaneously zoomed, while the Z axis (vertical) is left as before. The points in the XY view which were outside the rectangle **10122** are excluded from the elevational view. Likewise, any angle not represented in the selected set of points is excluded from the Yaw View, the Pitch View, and the Roll View. This process may be repeated as often as desired, until only a few camera positions are shown individually in the display.

The user may also create a rectangle within the Elev: XZ window, if desired. When the zoom-in push button **10146** is actuated, the selected rectangle fills the XZ window, and the X axis of the XY window is zoomed in the X axis only. Points not within the XZ selection rectangle are then excluded from the elevational view.

The user may also create a rectangle in the Yaw View window **10140**, the Pitch View window **10150**, or the Roll View window **10160**, if desired. When the zoom-in push button **10146** is actuated, the selected rectangle fills the window, and the Yaw, Pitch, or Roll values displayed within the selected rectangle expand to fill the display. Points in the Plan View: XY window **10120** and the Yaw View window **10140** which do not have yaw, pitch, and roll values within the resulting displayed Yaw View, Pitch View, and Roll View windows are excluded from the Plan View window and Elev XZ window.

Actuation of the zoom-out push button **10147** causes the plan and elevational displays to return to their original appearance (as shown in FIG. 19).

Actuating the Overlay Visibility . . . menu selection from the View menu causes the display of an Overlay Visibility dialog window **11110** (FIG. 29). The Overlay Visibility dialog lists five overlay items:—"Tombstones" **11120**, "Entrances" **11130**, "Exits" **11140**, "Launch Pads" **11150**, and "Grid (5)" **11160**—each of which may be selected for display in the Video windows or the Plan View window. A check box for each item is provided under the Video and Plan columns of the dialog **11122**, **11124**, **11132**, **11134**, **11142**, **11144**, **11152**, **11154**, **11162**. Check boxes under the Video column **11170** control display of items in the Video window **10110**, while those in the Plan column **11180** control display of items in the Plan View window **10120**. When the check box has an X in it, any overlay item of the corresponding type which may appropriately be displayed according to the current state of the program is displayed in the Video or Plan View window. Likewise, removing the X from the checkbox inhibits display of the corresponding line item.

The Overlay items listed above will be described later.

The final command in the View popdown menu is the Status command, which hides or displays a status line at the

bottom of the window **10190** and which indicates such things as the frame number and the X, Y, Z, Yaw, Pitch, and Roll coordinates of the camera corresponding to the image that is being displayed.

The Frame pop down menu displays the following commands, all of which relate to simply positioning the video as if it were a continuous video tape recording:

Home
Back
Forward
End

Additionally, the Frame pop down menu displays the following commands which have a special meaning:

Loop Forward
Loop Backward

The Loop Forward and Loop Backward selections cause the Video display to update with the next frame of video (Loop Forward) or previous frame (Loop Backward) in temporal sequence, continuously. Upon reaching the end of the video sequence, the sequence continues playback with the frame at the other end of the sequence, as though the video were joined in a continuous loop of film. Frames not shown in the Plan View window are skipped in the playback. Also, after each frame is shown, the Overlay Items appropriate to the frame are rendered onto the video frame display. The Overlay Items are described below.

The Loop Forward function may alternatively be started and stopped by striking the space bar. Each strike toggles the Loop Forward function between the started and stopped state.

The Action Menu has functions corresponding to the Toolbar buttons Zoom In **10146** and Zoom Out **10147**. It also has functions corresponding to the Head Forward button **10148** and Head Back button **10149**. Finally the Adjust Parameters function brings up a dialog box **10310** (FIG. 21) by which various parameters to be described later are adjusted.

The Head Forward **10148** and Head Back **10149** buttons and functions allow the user to move forward or back up from the currently displayed frame. The Head Forward frame and Head Back frame are shown as green dots **10123** and **10124** on the Plan View window, and as green rectangles **10420** and **10422** (FIG. 22) superimposed on the Video window. The Head Forward rectangle **10420** is projected onto the Video window and is superimposed on a spot on the Video window which corresponds to its spatial location as determined by the database. The Head Backward rectangle **10422** encloses the entire video area of the Video window.

The Head Forward frame is chosen by the program such that when it is displayed the appearance to the user is that the user has moved forward. This frame is selected in the following manner. Search all the frames in the telemetry file (*.tla) and determine which are within the front field of view angle from the perspective of the current frame.

The front field of view is defined here. Define a ray with its origin at the current frame's x-y location and extending in the direction of the yaw angle, called the centerline of the frame. Define a pair of rays with the same origin, called left and right lines of the frame, which make an angle with the centerline specified by the user in the Action-Adjust Parameters dialog (FIG. 21) Field of View Angle +/- item **10312**. Define a Field of View (fov) of the current frame between the left and right lines of the frame. All frame points which lie within the field of view are said to be frames within the current frame's field of view.

Of all the frames within the field of view (fov), determine which are within an operator specified radius (the Action-Adjust Parameters dialog Neighborhood Multiplier item **10320** (FIG. 21) times the Action-Adjust Parameters dialog

Neighbor Radius item **10318** (FIG. 21) of the current frame location and have a yaw angle that is within a specified maximum angular difference from the yaw angle goal. Of these candidate frames, find the frame that has the lowest valued FovIndexRating, defined as the sum of:

1. the absolute angular difference between the yaw angles of the current frame and the candidate frame, and
2. a weighted rating based on the distance of the xy location of the candidate frame from any point on the neighborhood circle around the current frame.

The weight given this distance error is proportional to the value of the Action-Adjust Parameters dialog Selecting Side Angles scroll bar item **10340** (FIG. 21). This allows the operator to adjust the importance of the minimization of yaw differences or distance from the circle.

Sometimes there is not an appropriate frame. In that case, none are selected and no corresponding overlay is displayed.

The Head Back frame is calculated in a similar manner to that used to the Head Forward frame with the exception that this frame must lie in the rear field of view. The rear field of view is a yaw angle range that can be found by reflecting the front field of view angle range to the back of the current frame. These fields of view are the same magnitude and face in opposite directions. For the case of jumping backward, the yaw angle goal is equal to the yaw angle of the current frame.

The keyboard Up-arrow-key and letter I key also execute the Head Forward function, the keyboard Down-arrow-key and letter K key also execute the Head Back function.

The View menu-Triple Mci function causes the MCIview window to expand to include three video windows (FIG. 20). The one in the center is the same. The left and right windows contain frames of video selected from the data set on the basis of their proximity to the best theoretical frames to display both in x-y-z and in centerline. The frame on the left is chosen so that its centerline is close to twice the fov of the center frame. Likewise the frame on the right is chosen so that its centerline is close to twice the fov of the center frame, but in a direction to the right of the center frame's centerline. For example, if the fov is 30 degrees (meaning that the left line is 30 degrees less than the centerline and the right line is 30 degrees greater than the centerline on a compass), a left frame would be searched for in the database with a center line of approximately 60 degrees less than the centerline of the current frame.

If no frame is found that meets the criteria for selection, no frame is displayed. If a frame has been chosen for the left frame or the right frame, that frame is displayed within its own MCIwnd, located to the left or the right of the center frame.

The left and right frames are aligned with the center frames based on the fov and on the yaw and pitch values of the centerlines of the frames. The fov defines a "pixel per degree" displacement on the screen. For each degree the left or right frame's centerline disagrees with the predicted centerline (center frame's centerline plus or minus twice the fov) the frame is shifted a corresponding number of pixels. Likewise, the frame is shifted up or down by the pixel per degree amount by which the frame's pitch differs from the center frame's pitch.

The left arrow key and the J key on the keyboard select a new frame for viewing. Initially the frame selected is the displayed left frame described above. The 0 through 9 keys allow the selection of a frame (if one exists) which has a centerline less than twice the fov angle. Pressing the 1 key sets the goal centerline angle to the centerline angle of the current frame plus or minus 10 percent of twice the fov angle. The 2 key similarly sets the goal centerline angle to 20 percent of

twice the fov angle. The 0 key sets the goal centerline angle to 100 percent of twice the fov angle. Note that this setting yields the frame which precisely abuts the center frame, since points on the edge of the center frame lie on a vertical plane extending from the current point of view which makes an angle of exactly "fov" degrees with the current frame centerline.

An overlay item represents a point or area of interest of the database as projected onto the current frame. Several overlay item types are defined by the movie mapper program. The overlay items which represent frames are the jump forward rectangle **10420** (FIG. 22), the jump backward rectangle **10422** (FIG. 22), the jump and turn left diamond **10424** (FIG. 22), the jump and turn right diamond **10426** (FIG. 22), the turn left triangle **11210** (FIG. 30), and the turn right triangle **11220** (FIG. 30). (See also **10220** in FIG. 20 where the left-turn triangle is shown in the panoramic view.)

Additionally, one or more frames may be defined as Entrance frames, marked on the Video Overlay window with an Entrance item **11230** (FIG. 30). An Entrance frame is a frame which is displayed as a result of the operator causing the viewer program to access a frame indexed within an area of the database known as an Exit area. The Exit area is described below. Like the Jump Forward frame, for example, the Entrance frame replaces the current frame in the video display window. An entrance frame may be contained within the same database which is currently being viewed, or may be from a different database. An entrance frame may be identified by the operator at any time by invoking the Objects-Create Entrance dialog **11300** (FIG. 31). The current frame is marked in the *.mta file associated with the currently open database with the operator supplied tag entered by the operator in the Entrance Name item **11320** (FIG. 31) of the Objects-Create Entrance dialog **11300** (FIG. 31). The Frame Number **11310** (FIG. 31) is supplied by the program when the dialog is invoked.

Three overlay item types describe areas rather than points. An Exit item marks an area of the Plan View containing frames of the current database which when viewed will cause the display of an associated Entrance frame. A Launch Pad area item **10722** (FIG. 25) causes the execution of an associated application program whenever a frame is displayed whose coordinates lie within the area defined for the Launch Pad area.

An Exit area is defined by the operator's actions:

The operator clicks on the Plan View window, holding the left mouse button down and moving the pointer to another point within the plan view window. This action creates a rectangle drawn on the Plan View **10122** (FIG. 19). The operator then invokes the Objects-Create Exit dialog **10500** (FIG. 23), and after filling in the dialog's entries, clicks the mouse on the OK button **10580** (FIG. 23). The dialog's Destination File item **10510** (FIG. 23) identifies the *.mta file associated with the database containing the desired Entrance, the named entrance which was defined by the procedure above. The Destination Name item **10520** (FIG. 23) selects the tag for the desired Entrance frame which was previously identified using the procedure described above for defining Entrance frames. Finally, the operator identifies the Exit area by entering an Exit name in the Exit Name item **10530** (FIG. 23), and completes the dialog by clicking the mouse on the OK button **10580** (FIG. 23).

A Launch Pad item is defined in a similar fashion. The operator clicks and drags on the Plan View window as above, and then invokes the Objects-Create Launch Pad dialog **10600** (FIG. 24). The operator fills in the Application File item **10610** (FIG. 24) with the name of an application to execute, the Command Line item **10620** (FIG. 24) with com-

mand line information if any, and gives the Launch Pad a name in the Launch Pad Name item **10630** (FIG. 24).

Each of these overlay items is projected onto the current video frame according to the overlay calculation code described above.

The Window pop down menu provides conventional Microsoft Windows window control functions that need not be described here. The Help popdown menu also needs no special explanation.

The object program structure of the movie mapper **325** is described in overview in FIG. 26, and the message paths connecting these program object elements are shown in FIG. 27. Taken together, and in conjunction with the preceding figures that illustrate the windows and program operation, FIGS. 19 to 35 present a full overview of the program **325**.

The operating program is composed of a number of objects each of which is an instance of some class of objects. These objects are represented by rectangles in FIGS. 26 and 27. Objects sometimes create subsidiary objects. When this happens, the subsidiary objects are represented in FIG. 26 by smaller rectangles contained within the larger object rectangles that gave rise to them. Each object has properties which correspond to its particular class. Each object class has a name, and the properties of the class are defined by separate program listings for each class. To aid the reader in pursuing these programs, FIG. 26 presents the hierarchical arrangement of the objects that are present in the program **325** when it is actually operating. The class name of each object appears within the rectangle for the object.

When the program commences operating, it first appears as an object named CVidApp **10902** (FIG. 26). This object then creates a frame window derived from the Microsoft class CMainFrame **10905**. This CMainFrame object appears on the screen as a large window frame **10100** (see FIG. 19) that includes a menu bar, a tool bar, and a status line, as has been described.

This CMainFrame object next launches a child frame derived from Microsoft's CMDIChildWnd that is of the class CMDITextWnd **10938**. This object gives rise to a child window that is modified from the Microsoft original in that its title line (positioned above the window) may be dynamically altered while the program is in operation.

This first child object launches within itself an instance of the CMCIView **10940** object, which launches MCIWnd **10944** to display the sequence of video images.

The CMciView object **10944** also launches a CMCIWnd object **10950**. The CMCIWnd object **10950** attaches itself to the MCIWnd object **10944** so that Windows operating system events come to the CMCIWnd **10950** object instead of being sent directly to the MCIWnd object **10944**. In most cases the CMCIWnd **10950** object merely forwards the events to the MCIWnd object **10944**. The CMCIWnd object **10950** intercepts mouse events, so that it may sense operator clicks on the overlay objects. The CMCIWnd object **10950** also intercepts MCIWnd redraw requests, forwards these requests to MCIWnd **10944** for video refresh, and then redraws the overlay objects associated with the video frame being displayed.

The CMciView and MCIView objects are the lower-most of the seven objects shown in FIG. 26 within the CMainFrame object **10905**. Accordingly, the user sees upon the screen a large window **10100** (FIG. 19) within which a small window **10110** appears having video playback control **10108**.

Six more windows may be opened by the user through activation of the View pop down menu, as has been described. Each of these windows corresponds to an additional pair of nested objects which appear within the CMainFrame object **10905** shown in FIG. 26.

If the user opens the Plan View: XY window **10120** (FIG. **19**), then the object **CMDITextWnd 10906** containing the object **CPlanView 10920** is created within the **CMainFrame** object **10905**, and this pair of objects together create the child window shown at **10120** in FIG. **19**. If the user opens the Elev

View: XZ window **10130**, then the object **CMDITextWnd 10911** containing the object **CElevView 10935** is created within the **CMainFrame** object **10905**, and this pair of objects together create the child window shown at **10130** in FIG. **19**. If the user opens the Orient View window **10180**, then the object **CMDITextWnd 10914** containing the object **COrientView 10945** is created within the **CMainFrame** object **10905**, and this pair of objects together create the child window shown at **10180** in FIG. **19**.

If the user opens the Yaw View window **10140**, then the object **CMDITextWnd 10918** containing the object **CYawView 10910** is created within the **CMainFrame** object **10905**, and this pair of objects together create the child window shown at **10140** in FIG. **19**.

If the user opens the Pitch View window **10195**, then the object **CMDITextWnd 10923** containing the object **CPitchView 10925** is created within the **CMainFrame** object **10905**, and this pair of objects together create the child window shown at **10195** in FIG. **19**.

If the user opens the Roll View window **10160**, then the object **CMDITextWnd 10923** containing the object **CRollView 10915** is created within the **CMainFrame** object, and this pair of objects together create the child window shown at **10160** in FIG. **19**.

As the user closes the windows, the corresponding pairs of objects are destroyed.

The objects, once created, send messages back and forth to each other over the paths illustrated in FIG. **27**. The following discussion does not consider messages directed to the window frames (to adjust the frame size, for example) and to the child window frame object instances **CMDITextWnd**, which are not shown to simplify FIG. **27**.

When the user “talks” to the program, using the keyboard or mouse, in general the user communicates with the active window (in the case of the keyboard) or the window that the mouse is in (in the case of the mouse), selecting a different active window by clicking within the window boundaries. The nine windows shown in FIG. **19** to which the user “talks” correspond to the ten objects numbered **10905**, **10910**, **10915**, **10920**, **10925**, **10935**, **10940**, **10944**, **10945**, and **10950** in FIGS. **26** and **27**. So these ten objects receive messages from the user and must respond.

The central coordinating object is the document object, which is an instance of **CVidDoc 10927** which is derived from the class **Cdocument** (a Microsoft class). This object contains the key system variables that determine the state of the system. Included, as illustrated in FIG. **27**, are the name of the file being processed, the number of the current frame being displayed, the current zoom level, the minimum and maximum values of coordinates that are used in the displays, and an object **10909** which is an instance of the class **Tla_File**, which stores and manipulates the positional data. (The minimum and maximum values of the coordinates are derived from the file data itself as the extreme values found within this object.)

If any window receives a message that calls for adjustment of one of the key system variables, that message is sent immediately to the document object **CVidDoc 10907**. The value of the key variable is adjusted, and then the document object **10907** broadcasts an “Update All Views” message over the path **10980** to the **MCIWnd** child window object **10944**, over path **10911** to object **10910**, over path **10921** to object **10920**, over path **10926** to object **10925**, over path **10916** to

object **10915**, over path **10936** to object **10935**, over path **10941** to object **10940**, and over path **10946** to object **10945**. Each responds accordingly. The “Update All Views” message contains a hint that says either:

1. Rewrite Everything, or
2. Just Do Current Frame.

The “rewrite everything” hint causes each window to be redrawn completely. The “just do current frame” hint causes, for example, just one point to be changed from blue to red.

The individual window objects next communicate with the document object **10907** over paths **10911**, **10916**, **10921**, **10926**, **10936**, **10941**, and **10946** and receive information via paths **10912**, **10917**, **10922**, **10927**, **10937**, **10942**, and **10947** to learn of the new state of the system and to retrieve from the document object **10907** whatever data they need to update their respective windows. For example, if the user at **10902** clicks upon the “zoom out” push button **10146** (FIG. **19**), this action is communicated to the object **CMainFrame 10905** associated with the outer window frame. The object **10905** communicates this message over the path **10904** to the document object **10907**. The Zoom Level variable is updated within the object **10907**, and an “Update All Views—Rewrite Everything” message is broadcast over the paths **10911**, **10916**, **10921**, **10926**, **10936**, **10941**, **10946**, and **10980** to the remaining objects, except for the **CMciWnd** object **10950**. This object receives its update messages before they are sent to the **MCIWnd** object **10944**, and are re-routed by the operating system. Then each of the objects **10910**, **10915**, **10920**, **10925**, **10935**, **10940**, and **10945** must send messages to the document object **10907** requesting all of the positional information (from “Tla_File”) so that they may repaint their plots of camera motion. They also request the current frame number so that they can color the plot of the current frame position red in color. The object **10944**, which simply needs to recompute and display the camera’s orientation when capturing the current frame, simply requests the current frame number and the positional data relevant to that one frame. The object **10944**, after verifying that the current frame value has not changed, simply does nothing in this case.

Double clicking on the path in one of the windows **10110**, **10120**, **10130**, **10140**, **10150**, **10160**, and **10180** (FIG. **19**) causes one of the objects **10910**, **10915**, **10920**, **10925**, **10935**, **10940**, or **10945** to send a message to the document object **10907** reporting a new value for the current frame number. In response, the document object broadcasts over the paths **10912**, **10917**, **10922**, **10927**, **10937**, **10942**, **10947**, and **10981** the message “Update All Views—Rewrite Everything” to the objects **10910**, **10915**, **10920**, **10925**, **10935**, **10940**, **10944** and **10945**. In response, the objects **10910**, **10915**, **10920**, **10925**, **10935**, **10940**, and **10945** redraw their plots totally, requesting the necessary data from the document object **10907**. The **CMCIView** object **10940**, after determining, that the current frame had changed, would request the display of the designated new frame by the **MCIWnd** object from Microsoft **10944**. That request is intercepted by **CMciWnd** object **10950**, which refreshes the overlay after the **MCIWnd** object **10944** finishes its update. When the user clicks upon one of the positioning controls **10142**, **10143**, **10144**, or **10145** in the tool bar (FIG. **19**), these actions are communicated over the path **10903** to the **CMainFrame** object **10905** which, in a similar manner, sends a frame update message over the path **10904** to the document object **10907** and triggers a similar response to that just described.

When the user activates the video controls within the child window **10110** (FIG. **19**) that contains the video image, the user is communicating directly with the Microsoft **MCIWnd** object **10944**. This object updates the display of the image as

requested and sends a message indicating the new frame number to the object CMCIView 10940. The object 10940 must then communicate this action to the document object 10907 over the path 10942. In this case, if the MCIWind viewer is playing the video as an animated display, then the document object 10907 broadcasts a message over the paths 10912, 10917, 10922, 10927, 10937, 10942, 10947, and 10980 "Update All Views—Just Do Current Frame." Accordingly, the objects 10910, 10915, 10920, 10925, 10935, 10940, and 10945 need simply to request information concerning the new current frame.

The program provides the facility of navigating through the video database by selecting frames of data from the database which represent translations and rotations from the position of the current frame's point of view. The program searches the database for frames which best meet the criteria, and the

operator then selects one of these frames using the keys or mouse as described above. The following paragraphs describe the method the program uses to select the best frame for each of the possible operator choices (turn left, turn right, 5 jump forward, jump backward, jump forward and simultaneously turn right, jump forward and simultaneously turn left).

First, the program initializes variables which are used to keep track of the best entry found for each of the selections above. Cw_slope is clockwise, and ccw_slope is counter-clockwise. Fov is the slope data for the current frame. Left-Diag is the slope data for the frame to the left of the current frame, its centerline close to twice the fov counterclockwise of the current frame's centerline. RightDiag is the slope data for the frame to the right of the current frame, its centerline close to twice the fov clockwise of the current frame's centerline. 15

```

void Tla_File::select_field_of_view(unsigned short current_frame)
{
    unsigned short fov_subset_index = MIN_FRAME_COUNT;// index used w/ subset array
    unsigned short subset_index; // index used w/ data arrays
    SlopeData Fov;
    SlopeData LeftDiag;
    SlopeData RightDiag;
    float IndexCurrentSlope;
    int current_x = get_x_data(current_frame); // get x coor for current frame
    int current_y = get_y_data(current_frame); // get y coor for current frame
    int index_x; // a coor of point/frame under test of being in camera's field of view
    int index_y;
    BOOL same_location; // true if indexed point and current point are same point or location
    BOOL in_front_fov; // true if indexed point is in the camera's field of view at current pt
    BOOL in_rear_fov; // true if indexed point is in the current pt camera's rear view mirror's fov
    BOOL in_left_diag; // true if indexed point is in the left diagonal's range as seen from current
    pt
    BOOL in_right_diag; // true if indexed point is in the right diagonal's range as seen from current
    pt
    // time saving combination used in side frame selection tradeoff
    // m_Selecting_Tradeoff is 1 to 17
    float DistanceGain = (float)(NEUTRAL_DIST_GAIN * m_Selecting_Tradeoff /
    DEFAULT_PRIORITY); // ~1/6 to 2+
    // calc slope of line of clockwise field of view limit within the xy plan (plan view)
    Fov.cw_slope = get_yaw_data(current_frame) - (m_HorzFieldOfViewAngle / 2);
    // calc slope of line of counterclockwise field of view limit within the xy plan (plan view)
    Fov.ccw_slope = get_yaw_data(current_frame) + (m_HorzFieldOfViewAngle / 2);
    CalcSlopeData converts the cw_slope and ccw_slope angles of the current frame to the
    tangent of the angles, with quadrant.
    (FIG. 33, step 11520)
    CalcSlopeData(&Fov); // calc variables used in testing slope limits. Means of testing if yaw in
    bounds
    // sets goal for side frame selection as fraction of m_HorzFieldOfViewAngle
    float TurnAngleGoal = m_SideFrameGain * m_HorzFieldOfViewAngle;
    // left is ccw and TurnAngleGoal is added to turn left
    // right is cw and TurnAngleGoal is subtracted to turn right
    if (TurnAngleGoal > m_MaxHeadingAngle) // note this is a new use for m_MaxHeadingAngle
    {
        // want right most limit of left diag range to be left of current yaw
        LeftDiag.cw_slope = get_yaw_data(current_frame) + TurnAngleGoal -
        m_MaxHeadingAngle;
        // want left most limit of right diag range to be right of current yaw
        RightDiag.ccw_slope = get_yaw_data(current_frame) - TurnAngleGoal +
        m_MaxHeadingAngle;
    }
    else
    {
        LeftDiag.cw_slope = get_yaw_data(current_frame);
        RightDiag.ccw_slope = get_yaw_data(current_frame);
    }
    // note this is a new use for m_MaxHeadingAngle
    LeftDiag.ccw_slope = get_yaw_data(current_frame) + TurnAngleGoal +
    m_MaxHeadingAngle;
    RightDiag.cw_slope = get_yaw_data(current_frame) - TurnAngleGoal -
    m_MaxHeadingAngle;
    CalcSlopeData converts the cw_slope and ccw_slope angles of the LeftDiag and RightDiag to the
    tangent of the angles, with quadrant.
    (FIG. 33, step 11530)

```

-continued

```

CalcSlopeData(&LeftDiag); // calc variables used in testing slope limits. Means of testing if
yaw in bounds
CalcSlopeData(&RightDiag); // calc variables used in testing slope limits. Means of testing if
yaw in bounds
m_FovSubsetIndexMax = NO_FRAMES;
float CurrentPointYaw = get_yaw_data(current_frame); // use for finding most aligned fov pt
float IndexPointYaw;
float Cos_CurrentPointYaw = (float)cos(CurrentPointYaw * DEG_TO_RAD);
float Sin_CurrentPointYaw = (float)sin(CurrentPointYaw * DEG_TO_RAD);
float xCurrentMinusIndex; // diff in x between current pt and index pt
float yCurrentMinusIndex; // diff in y between current pt and index pt
// in these rating, smaller is better
// used for selecting best frames to use for right and left mcivnds
float AdjIndexCurrentDistanceRating; // rating by distance from current point adj for
// angle
float WeightedRadiusDistanceRating; // rating by distance from neighbor hood radius
float LeftIndexRating; // measure of merit for indexed pt as left pt
float RightIndexRating; // measure of merit for indexed pt as right pt
float FovIndexRating; // measure of merit for indexed pt as fwd jump pt
float FwdSmallestDisplayRating = HIGH_VALUE_RATING; // best measure of merit for
// fwd jump pt so far
float RearSmallestDisplayRating = HIGH_VALUE_RATING; // best measure of merit for
// rear jump pt so far
float LeftSmallestDisplayRating = HIGH_VALUE_RATING; // best measure of merit for
// left display pt so far
float RightSmallestDisplayRating = HIGH_VALUE_RATING; // best measure of merit for
// right display pt so far
float LeftSmallestTurnRating = HIGH_VALUE_RATING; // best measure of merit for
// left turn pt so far
float RightSmallestTurnRating = HIGH_VALUE_RATING; // best measure of merit for
// right turn pt so far
float LeftSmallestDiagRating = HIGH_VALUE_RATING; // best measure of merit for
// left diag turn pt so far
float RightSmallestDiagRating = HIGH_VALUE_RATING; // best measure of merit for
// right diag turn pt so far
float DisplayYawAbsDiff; // abs diff in yaw of limit yaw + trial display pts
float TurnYawAbsDiff; // abs diff in yaw of limit yaw + trial turn pts
float CurrentIndexYawAbsDiff; // abs diff in yaw of current and index pts
float IndexCurrentYawDiff; // signed diff in yaw of current and index pts
BOOL IndexYawToLeftOfCurrentYaw; // is candidate frame's yaw pointing to left of
// current yaw
float DistanceSquared; // square of distance betw index and current pts.
float NeighborRadiusSquared = m_NeighborRadius * m_NeighborRadius;
// sq of neighborhood radius
float MultipliedNeighborRadiusSquared // sq of multiplied limit of neighborhood radius
= m_NeighborhoodMultiplier * m_NeighborhoodMultiplier *
NeighborRadiusSquared;

```

The result variables are set to reflect the selection results when no frames are found. (FIG. 33, step 11510)

```

m_FovPtClosestInYaw = NO_FRAMES; // no closest point
m_RearFovPtClosestInYaw = NO_FRAMES; // no closest point
m_PtLeftFOV = current_frame; // if find nothing better, show behind current
// point
m_PtRightFOV = current_frame; // if find nothing better, show behind current
// point;
m_PtLeftTurn = current_frame; // if find nothing better, show over current point;
// no closest point
m_PtRightTurn = current_frame; // if find nothing better. show over current point;
m_PtLeftDiag = NO_FRAMES;
m_PtRightDiag = NO_FRAMES;
float LeftFovPtYaw = CurrentPointYaw + m_HorzFieldOfViewAngle; // don't
// worry
// if > 180'
float RightFovPtYaw = CurrentPointYaw - m_HorzFieldOfViewAngle; // don't
// worry
// if < -180'
float Left2FovPtYaw = CurrentPointYaw + (2 * m_HorzFieldOfViewAngle); // don't
// worry
// if > 180'
float Right2FovPtYaw = CurrentPointYaw - (2 * m_HorzFieldOfViewAngle); // don't
// worry
// if < -180'
float LeftTurnPtYaw = CurrentPointYaw + TurnAngleGoal; // don't
// worry
// if > 180'
float RightTurnPtYaw = CurrentPointYaw - TurnAngleGoal; // don't
// worry
// if < 180'

```

Now iterate through all frames in the database. (FIG. 32, Steps 11430, 11450, and 11465) The search may be limited to a subset of the all the frames in the database, if the operator has zoomed in on one

-continued

```

of the data windows (Plan View, Elev. View, Yaw View, Pitch View, Roll View).
unsigned short frame_index;
if (m_zoom_subset_index_max != NO_FRAMES) // If there are points in reg subset
{
    for (subset_index = MIN_FRAME_COUNT;
        subset_index <= m_zoom_subset_index_max; // do all pts in reg subset defined by views
        subset_index++)
    )
    {
        in_front_fov = FALSE;
        in_rear_fov = FALSE;
        in_left_diag = FALSE;
        in_right_diag = FALSE;
        frame_index = get_frame_from_zoom_subset(subset_index);
        IndexPointYaw = get_yaw_data(frame_index);
    }
}

Get the X and Y data for the frame. (FIG. 34, step 11610) In this loop "index" is the index of the
frame being tested. "Current" is the index of the currently displayed frame.
index_x = get_x_data(frame_index);
index_y = get_y_data(frame_index);
// calc offset using normal x,y axes
xCurrentMinusIndex = current_x - index_x;
yCurrentMinusIndex = current_y - index_y;

Calculate distance from current frame's location to index frame's location on plan view. (FIG. 34,
step 11620)
DistanceSquared = (float)(xCurrentMinusIndex*xCurrentMinusIndex +
yCurrentMinusIndex*yCurrentMinusIndex);
// calc slope of line from current point to point under test (subset_index point)
// first prevent divide by zero
same_location = FALSE;

Calculate yaw difference between current frame and index frame. Make sure to keep result in range
of +/- 180 degrees. (FIG. 34, step 11630)
IndexCurrentYawDiff = IndexPointYaw - CurrentPointYaw; // pos yaw is counter clockwise
if (((IndexCurrentYawDiff >= 0) // if candidate's yaw is closer to current pt's yaw in ccw dir
&& (IndexCurrentYawDiff <= 180) // but no wrap around that makes far really close on
other side
)
|| (IndexCurrentYawDiff < -180) // appears to be clockwise
// but does wrap around so makes big duff really close on
other side
)
{
    IndexYawToLeftOfCurrentYaw = TRUE;
}
else
{
    IndexYawToLeftOfCurrentYaw = FALSE;
}

CurrentIndexYawAbsDiff = (float)(fabs(CurrentPointYaw - IndexPointYaw));
// Cant be further apart than 180
if (CurrentIndexYawAbsDiff >= 180)
{
    CurrentIndexYawAbsDiff = 360 - CurrentIndexYawAbsDiff;
}

Test for special cases of slope for the line between the index and the current. The math calculation
causes an error if the slope is vertical.
Then calculate slope in the more general case. (FIG. 34, step 11640)
// you would think that checking index_x and index_y would catch this
// but the math is sometimes inexact evidently so explicitly check if same point
if (current_frame == frame_index)
{
    // two points are on exactly same spot. You cant see yourself in your field of
    view
    IndexCurrentSlope = 0; // s/b undefined, really.
    same_location = TRUE;
}
else
{
    if (index_x == current_x)
    {
        if (index_y > current_y)
        {
            IndexCurrentSlope = MAX_SLOPE;
        }
        else if (index_y < current_y)
        {
            IndexCurrentSlope = -MAX_SLOPE;
        }
    }
    else
    {
        // two points are on exactly same spot. You cant see yourself in your field of

```

-continued

```

        view
        IndexCurrentSlope = 0;           // s/b undefined, really.
        same_location = TRUE;
    }
}
else // ok to calc slope. no divide by zero
{
    IndexCurrentSlope = ((float)index_y - current_y) / (index_x - current_x);
}
}

Test the indexed point to find if it is in the front or rear field of view (fov) of the current frame, in the
RightDiag's fov, or in the LeftDiag's fov. Jump and turn right's frame will be selected from the
RightDiag fov. Jump and turn left's frame will be selected from the LeftDiag fov. (FIG. 34, step
11650)
// So, is the indexed point within the FRONT field of view of current point?
// Is it between the cw and ccw slope limits? If so, then in fov
// Note. Here x,y are data x,y, not display pixel x,y. First quadrant is pos x and pos y.
if ( index_y >= current_y)
{
    if (index_x >= current_x)           // index_quadrant = FIRST_QUADRANT;
    {
        // slopes in this quadrant are positive. pos x/ pos y
        if (( (Fov.cw_quadrant == FIRST_QUADRANT) // both same quadrant
            && (IndexCurrentSlope >= Fov.cw_slope) // proper relationship
            )
            || ( Fov.cw_quadrant == FOURTH_QUADRANT) // (IndexCurrentSlope >=
            cw_slope) is automatic here
            )
        {
            if (( (Fov.ccw_quadrant == FIRST_QUADRANT) // both same quadrant
                && (IndexCurrentSlope <= Fov.ccw_slope) // proper relationship
                )
                || (Fov.ccw_quadrant == SECOND_QUADRANT) // (IndexCurrentSlope <=
                cw_slope) is automatic here
                )
            {
                in_front_fov = TRUE;
            }
        }
        // ccw
    }
    // cw
    // see if in left diag yaw range
    if (( (LeftDiag.cw_quadrant == FIRST_QUADRANT) // both same quadrant
        && (IndexCurrentSlope >= LeftDiag.cw_slope) // proper relationship
        )
        || ( LeftDiag.cw_quadrant == FOURTH_QUADRANT) // (IndexCurrentSlope >=
        cw_slope) is automatic here
        )
    {
        if (( (LeftDiag.ccw_quadrant == FIRST_QUADRANT) // both same quadrant
            && (IndexCurrentSlope <= LeftDiag.ccw_slope) // proper relationship
            )
            || (LeftDiag.ccw_quadrant == SECOND_QUADRANT) // (IndexCurrentSlope <=
            cw_slope) is automatic here
            )
        {
            in_left_diag = TRUE;
        }
    }
    // ccw
}
// cw
// see if in right diag yaw range
if (( (RightDiag.cw_quadrant == FIRST_QUADRANT) // both same quadrant
    && (IndexCurrentSlope >= RightDiag.cw_slope) // proper relationship
    )
    || ( RightDiag.cw_quadrant == FOURTH_QUADRANT) // (IndexCurrentSlope >=
    cw_slope) is automatic here
    )
{
    if (( (RightDiag.ccw_quadrant == FIRST_QUADRANT) // both same quadrant
        && (IndexCurrentSlope <= RightDiag.ccw_slope) // proper relationship
        )
        || (RightDiag.ccw_quadrant == SECOND_QUADRANT) // (IndexCurrentSlope <=
        cw_slope) is automatic here
        )
    {
        in_right_diag = TRUE;
    }
}
// ccw
}
// cw
// if quadrant
}
else // (index_x < current_x)           index_quadrant = SECOND_QUADRANT;
{
    // slopes in this quadrant are negative. neg x/ pos y
    if (( (Fov.cw_quadrant == SECOND_QUADRANT) // both same quadrant
        && (IndexCurrentSlope >= Fov.cw_slope) // greater than here means less negative
        )
    )
}

```

-continued

```

    || (Fov.cw_quadrant == FIRST_QUADRANT) // must be ok so far
    )
    {
    if (( (Fov.cw_quadrant == SECOND_QUADRANT) // both same quadrant
        && (IndexCurrentSlope <= Fov.cw_slope) // less than here means more negative
        )
        )
        || (Fov.cw_quadrant == THIRD_QUADRANT) // must be ok
        )
        {
        in_front_fov = TRUE;
        } // ccw
    } // cw
} // see if in left diag yaw range
if (( (LeftDiag.cw_quadrant == SECOND_QUADRANT) // both same quadrant
    && (IndexCurrentSlope >= LeftDiag.cw_slope) // greater than here means less negative
    )
    )
    || (LeftDiag.cw_quadrant == FIRST_QUADRANT) // must be ok so far
    )
    {
    if (( (LeftDiag.cw_quadrant == SECOND_QUADRANT) // both same quadrant
        && (IndexCurrentSlope <= LeftDiag.cw_slope) // less than here means more negative
        )
        )
        || (LeftDiag.cw_quadrant == THIRD_QUADRANT) // must be ok
        )
        {
        in_left_diag = TRUE;
        } // ccw
    } // cw
    // see if in right diag yaw range
    if (( (RightDiag.cw_quadrant == SECOND_QUADRANT) // both same quadrant
        && (IndexCurrentSlope >= RightDiag.cw_slope) // greater than here means less negative
        )
        )
        || (RightDiag.cw_quadrant == FIRST_QUADRANT) // must be ok so far
        )
        {
        if (( (RightDiag.cw_quadrant == SECOND_QUADRANT) // both same quadrant
            && (IndexCurrentSlope <= RightDiag.cw_slope) // less than here means more negative
            )
            )
            || (RightDiag.cw_quadrant == THIRD_QUADRANT) // must be ok
            )
            {
            in_right_diag = TRUE;
            } // ccw
        } // cw
        // else quadrant
    }
} // (index_y < current_y)
else
{
if (index_x >= current_x) // index_quadrant = FOURTH_QUADRANT;
{
// slopes in this quadrant are negative. pos x/ neg y
if (( (Fov.cw_quadrant == FOURTH_QUADRANT) // both same quadrant
    && (IndexCurrentSlope >= Fov.cw_slope) // greater than here means less negative
    )
    )
    || (Fov.cw_quadrant == THIRD_QUADRANT)
    )
    {
    if (( (Fov.cw_quadrant == FOURTH_QUADRANT) // both same quadrant
        && (IndexCurrentSlope <= Fov.cw_slope) // less than here means more negative
        )
        )
        || (Fov.cw_quadrant == FIRST_QUADRANT)
        )
        {
        in_front_fov = TRUE;
        } // ccw
    } // cw
} // see if in left diag yaw range
if (( (LeftDiag.cw_quadrant == FOURTH_QUADRANT) // both same quadrant
    && (IndexCurrentSlope >= LeftDiag.cw_slope) // greater than here means less negative
    )
    )
    || (LeftDiag.cw_quadrant == THIRD_QUADRANT)
    )
    {
    if (( (LeftDiag.cw_quadrant == FOURTH_QUADRANT) // both same quadrant
        && (IndexCurrentSlope <= LeftDiag.cw_slope) // less than here means more negative
        )
        )
        || (LeftDiag.cw_quadrant == FIRST_QUADRANT)
        )
        {
        in_left_diag = TRUE;
        } // ccw
    }
}

```

-continued

```

    }
    // (Fov.rear_ccw_quadrant == THIRD_QUADRANT) // must be ok
    }
    {
    in_rear_fov = TRUE;
    } // ccw
    } // cw
    // else quadrant
}
else // (index_y < current_y)
{
if (index_x >= current_x) // index_quadrant = FOURTH_QUADRANT;
{
if ((Fov.rear_cw_quadrant == FOURTH_QUADRANT) // both same
quadrant
&& (IndexCurrentSlope >= Fov.cw_slope) // proper relationship
)
// (Fov.rear_cw_quadrant == THIRD_QUADRANT)
)
{
if ((Fov.rear_ccw_quadrant == FOURTH_QUADRANT) // both same
quadrant
&& (IndexCurrentSlope <= Fov.cw_slope) // proper relationship
)
// (Fov.rear_ccw_quadrant == FIRST_QUADRANT)
)
{
in_rear_fov = TRUE;
} // ccw
} // cw
// if quadrant
} // (index_x < current_x) index_quadrant =
THIRD_QUADRANT;
else
{
if ((Fov.rear_cw_quadrant == THIRD_QUADRANT) // both same
quadrant
&& (IndexCurrentSlope >= Fov.cw_slope) // proper relationship
)
// (Fov.rear_cw_quadrant == SECOND_QUADRANT)
)
{
if ((Fov.rear_ccw_quadrant == THIRD_QUADRANT) // both same
quadrant
&& (IndexCurrentSlope <= Fov.cw_slope) // proper relationship
)
// (Fov.rear_ccw_quadrant == FOURTH_QUADRANT)
)
{
in_rear_fov = TRUE;
} // ccw
} // cw
// else quadrant
}
}
}
// see if have new champion, find rear fov pt most aligned in yaw to current
frame
if (in_rear_fov) // if in rear view field of view
{
if (m_RearFovPtClosestInYaw == NO_FRAMES) // if we don't have a current
champion
{
// add criterion of keeping inside twice the neighborhood radius
if ((MultipliedNeighborRadiusSquared >= DistanceSquared) // in the double
hood
)
// Use this point only if it is not too different from current point's heading
// Note the first champ is closer to the current angle difference than max limit
&& (CurrentIndexYawAbsDiff < m_MaxHeadingAngle)
)
{
m_RearFovPtClosestInYaw = subset_index;
RearSmallestDisplayRating = FovIndexRating; // save for next candidate
comparison
}
}
}
else // have a valid champ
{
// if this rear fov pt has smaller total rating than defending champ
if ((RearSmallestDisplayRating > FovIndexRating)
// add criterion of keeping inside twice the neighborhood radius
&& (MultipliedNeighborRadiusSquared >= DistanceSquared) // in the hood
)
// Use this point only if it is not too different from current point's heading
// Note the first champ is closer to the current angle difference than max

```

-continued

```

        limit
        && (CurrentIndexYawAbsDiff < m_MaxHeadingAngle)
        )
        {
        m_RearFovPtClosestInYaw = subset_index;
        RearSmallestDisplayRating = FovindexRating;           // save for next candidate
                                                                comparison
        }
        // end if new champ beats old champ
    }
    // end else have a valid champ
}
// end if in rear fov
}
// end else not in front fov
}
// end if not same location
if m_FovPtClosestInYaw == current_frame)           // s/b impossible but ...
{
    AfxMessageBox("Tla_File::select_field_of_view( ) m_FovPtClosestInYaw ==
current_frame");
}
if (m_RearFovPtClosestInYaw == current_frame)       // s/b impossible but ...
{
    AfxMessageBox("Tla_File::select_field_of view( ) m_RearFovPtClose_stInYaw ==
current_frame");
}
Test index point to see if it is better than the current candidate for the jump and turn right or jump
and turn left selection. (FIG. 32, step 11495)
// looking for side frame candidates
if ((NeighborRadiusSquared >= DistanceSquared)           // in the hood
    && (Isame_location)           // and indexed and current points do not have identical
                                x,y location
)
{
    // the trig is there to forgive offset if the side frame is pointing in line
    // w/ the offset vector
    // running from the current center point to the side frame. This is
    // because offsets are less
    // noticeable if there are in the direction in which you are looking.
    // Move your head forward
    // and back like a pigeon. Some movement of objects but not as
    // much as when you move
    // your head left and right. Don't want to forgive completely so put
    // in a minimum.
    AdjIndexCurrentDistanceRating
    = (float)((fabs(xCurrentMinusIndex * (fabs_quick_cos(IndexPointYaw) + 0.2))
    + fabs(yCurrentMinusIndex *
    (fabs_quick_sin(IndexPointYaw) + 0.2))
    )
    * DistanceGain
    );
    // do left displayed frame
    if (IndexYawToLeftOfCurrentYaw == TRUE)
    {
        DisplayYawAbsDiff = (float)(fabs(LeftFovPtYaw - IndexPointYaw));
        // Cant be further apart than 180
        if (DisplayYawAbsDiff >= 360)
        {
            DisplayYawAbsDiff -= 360;
        }
        else if (DisplayYawAbsDiff >= 180)
        {
            DisplayYawAbsDiff = 360 - DisplayYawAbsDiff;
        }
        // within neighborhood, within constrained subset
        m_MaxHeadingAngle
        // if this pt is closer in yaw and in distance to goal than defending
        champ
        LeftIndexRating = DisplayYawAbsDiff + AdjIndexCurrentDistanceRating;
        if (LeftSmallestDisplayRating > LeftIndexRating)
        {
            // if is actually pointing to the correct side but
            // not too far out
            if (Left2FovPtYaw <= 180)           // nothing weird
            {
                if ((IndexPointYaw > CurrentPointYaw)
                    && (Left2FovPtYaw >= IndexPointYaw)
                )
                {
                    // convert from subset index to frame
                    m_PtLeftFOV = frame_index;
                    LeftSmallestDisplayRating = LeftIndexRating; // save it as
                                                                benchmark
                }
            }
        }
    }
}

```

-continued

```

    }
else
    {
        // weird range split by +/- 180 line
        if ((IndexPointYaw > CurrentPointYaw)
            || (Left2FovPtYaw >= IndexPointYaw + 360)
        )
        {
            // convert from subset index to frame
            m_PtLeftFOV = frame_index;
            LeftSmallestDisplayRating = LeftIndexRating; // save it as benchmark
        }
    }
}

Test index point to see if it is better than the current candidate for turn left turn or right turn selection.
(FIG. 32, step 11495)

// now choose the left turn frame
TurnYawAbsDiff = (float)(fabs(LeftTurnPtYaw - IndexPointYaw));
// Cant be further apart than 180
if (TurnYawAbsDiff >= 360)
{
    TurnYawAbsDiff -= 360;
}
else if (TurnYawAbsDiff >= 180)
{
    TurnYawAbsDiff = 360 - TurnYawAbsDiff;
}

// within neighborhood, within constrained subset
m_MaxHeadingAngle
// if this pt is closer in yaw and in distance to goal than
defending champ
LeftIndexRating = TurnYawAbsDiff + AdjIndexCurrentDistanceRating;
if (LeftSmallestTurnRating > LeftIndexRating)
{
    // if is actually pointing to the correct side
    // but not too far out
    // nothing weird
    if (Left2FovPtYaw <= 180)
    {
        if ((IndexPointYaw > CurrentPointYaw)
            && (Left2FovPtYaw >= IndexPointYaw)
        )
        {
            // convert from subset index to frame
            m_PtLeftTurn = frame_index;
            LeftSmallestTurnRating = LeftIndexRating; // save it as benchmark
        }
    }
}
else
    {
        // weird range split by +/- 180 line
        if ((IndexPointYaw > CurrentPointYaw)
            || (Left2FovPtYaw >= IndexPointYaw + 360)
        )
        {
            // convert from subset index to frame
            m_PtLeftTurn = frame_index;
            LeftSmallestTurnRating = LeftIndexRating; // save it as benchmark
        }
    }
}
}

// end if IndexYawToLeftOfCurrentYaw
// on index yaw is to the right of the current yaw
{
    // do right displayed frame
    DisplayYawAbsDiff = (float)(fabs(RightFovPtYaw - IndexPointYaw));
    // Cant be further apart than 180
    if (DisplayYawAbsDiff >= 360)
    {
        DisplayYawAbsDiff -= 360;
    }
    else if (DisplayYawAbsDiff >= 180)
    {
        DisplayYawAbsDiff = 360 - DisplayYawAbsDiff;
    }

    // within neighborhood, within constrained subset
    m_MaxHeadingAngle
    // if this pt is closer in yaw and in distance to goal than
    defending champ
    RightIndexRating = DisplayYawAbsDiff + AdjIndexCurrentDistanceRating;
}

```

-continued

```

if (RightSmallestDisplayRating > RightIndexRating)
{
// if is actually pointing to the correct side but
// not too far out
if (Right2FovPtYaw >= -180) // nothing weird
{
if ((IndexPointYaw < CurrentPointYaw)
&& (Right2FovPtYaw <= IndexPointYaw)
)
{
// convert from subset index to frame
m_PtRightFOV = frame_index;
RightSmallestDisplayRating = RightIndexRating; // save it as
benchmark
}
}
else // weird range split by +/- 180 line
{
if ((IndexPointYaw < CurrentPointYaw)
&& (Right2FovPtYaw <= IndexPointYaw - 360)
)
{
// convert from subset index to frame
m_PtRightFOV = frame_index;
RightSmallestDisplayRating = RightIndexRating; // save it as
benchmark
}
}
} // end if m_PtRightFOV
// now choose the right turn frame
TurnYawAbsDiff = (float)(fabs(RightTurnPtYaw - IndexPointYaw));
// Cant be further apart than 180
if (TurnYawAbsDiff >= 360)
{
TurnYawAbsDiff -= 360;
}
else if (TurnYawAbsDiff >= 180)
{
TurnYawAbsDiff = 360 - TurnYawAbsDiff;
}
// within neighborhood, within constrained subset
// if this pt is closer in yaw and in distance to goal than
// defending champ
RightIndexRating = TurnYawAbsDiff + AdjIndexCurrentDistanceRating;
if (RightSmallestTurnRating > RightIndexRating)
{
// if is actually pointing to the correct side but
// not too far out
if (Right2FovPtYaw >= -180) // nothing weird
{
if ((IndexPointYaw < CurrentPointYaw)
&& (Right2FovPtYaw <= IndexPointYaw)
)
{
// convert from subset index to frame
m_PtRightTurn = frame_index;
RightSmallestTurnRating = RightIndexRating; // save it as
benchmark
}
}
else // weird range split by +/- 180 line
{
if ((IndexPointYaw < CurrentPointYaw)
&& (Right2FovPtYaw <= IndexPointYaw - 360)
)
{
// convert from subset index to frame
m_PtRightTurn = frame_index;
RightSmallestTurnRating = RightIndexRating; // save it as
benchmark
}
}
} // end if m_PtRightTurn
// end if not IndexYawToLeftOfCurrentYaw
// end if within neighborhood radius
}
}
Test index point to see if it is better than the current candidate for turn left frame or right frame display in
Triple Mci display mode. (FIG. 32, step 11495)
if (in_left_diag) // if in range
{
// now choose the left diag frame

```

-continued

```

TurnYawAbsDiff = (float)(fabs(LeftTurnPtYaw - IndexPointYaw));
// Cant be further apart than 180
if (TurnYawAbsDiff >= 360)
{
    TurnYawAbsDiff -= 360;
}
else if (TurnYawAbsDiff >= 180)
{
    TurnYawAbsDiff = 360 - TurnYawAbsDiff;
}
LeftIndexRating = TurnYawAbsDiff + WeightedRadiusDistanceRating;
if ((m_PtLeftDiag == NO_FRAMES) // if we don't have a current champion
    // or if this pt is closer in yaw and in distance to goal than defending champ
    || (LeftSmallestDiagRating > LeftIndexRating)
    )
{
    // the absolute standards
    if ((MultipliedNeighborRadiusSquared >= DistanceSquared) // in the double
        hood
        // Use this point only if it is not too different from turn point's heading
        // Note the first champ is closer to the current angle difference than max
        limit
        && (TurnYawAbsDiff < m_MaxHeadingAngle)
        )
    {
        // convert from subset index to frame
        m_PtLeftDiag = frame_index;
        LeftSmallestDiagRating = LeftIndexRating; // save it as benchmark
    }
} // end if in diag range
if (in_right_diag) // if in range
{
    // now choose the left diag frame
    TurnYawAbsDiff = (float)(fabs(RightTurnPtYaw - IndexPointYaw));
    // Cant be further apart than 180
    if (TurnYawAbsDiff >= 360)
    {
        TurnYawAbsDiff -= 360;
    }
    else if (TurnYawAbsDiff >= 180)
    {
        TurnYawAbsDiff = 360 - TurnYawAbsDiff;
    }
    RightIndexRating = TurnYawAbsDiff + WeightedRadiusDistanceRating;
    if ((m_PtRightDiag == NO_FRAMES) // if we don't have a current champion
        // or if this pt is closer in yaw and in distance to goal than defending champ
        || (RightSmallestDiagRating > RightIndexRating)
        )
    {
        // the absolute standards
        if ((MultipliedNeighborRadiusSquared >= DistanceSquared) // in the double
            hood
            // Use this point only if it is not too different from turn point's heading
            // Note the first champ is closer to the current angle difference than max
            limit
            && (TurnYawAbsDiff < m_MaxHeadingAngle)
            )
        {
            // convert from subset index to frame
            m_PtRightDiag = frame_index;
            RightSmallestDiagRating = RightIndexRating; // save it as benchmark
        }
    } // end if in diag range
} // end for
if (m_PtLeftFOV == NO_FRAMES)
{
    AfxMessageBox("Tla_File::select_field_of_view( ) m_PtLeftFOV ==
NO_FRAMES");
}
if (m_PtRightFOV == NO_FRAMES)
{
    AfxMessageBox("Tla_File::select_field_of_view( ) m_PtRightFOV ==
NO_FRAMES");
}
if (m_FovPtClosestInYaw != NO_FRAMES) // if picked a point
{
    if (get_frame_from_zoom_subset(m_FovPtClosestInYaw) ==
current_frame) // s/b impossible
but ...

```

-continued

```

    {
        AfxMessageBox("Tla_File::select_field_of_view( ) m_FovPtClosestInYaw ==
current_frame");
    }
} // end if not m_zoom_subset_index_max
return:
}
}

```

The overlay window relates points and areas in the geometric space defined by the camera's movements to points and areas within a particular video frame. Geometric points and areas within the geometric space are projected to the camera's image plane using the following formula (In this code fragment the calculation is done for a Tombstone type overlay, but the calculation is the same for any overlay object.):

```

    First, get the difference between the camera frame's x position and the overlay
    object's x position. (FIG. 35, step 11710)
    numerator = -(m_pDoc->m_mta_file.m_Tombstone[index].XCtr
        - m_pDoc->m_tla_file.get_x_data(ThisWndsFrame)
        );
    Next, get the difference between the camera frame's y position and the overlay object's y position. (FIG.
    35, step 11720)
    denominator = (m_pDoc->m_mta_file.m_Tombstone[index].YCtr
        - m_pDoc->m_tla_file.get_y_data(ThisWndsFrame)
        );
    Calculate yaw angle of the line from the current frame's center to the point of interest. (FIG. 35, step
    11730)
    // calc angle of line from current point to this active tombstone
    if (denominator != 0) // don't divide by zero
    {
        yawFrameToOverlay = (float)(RAD_TO_DEG * atan2(numerator, denominator));
    }
    else // denom is zero
    {
        // make ratio of num/denom big via a small denominator but avoid div by zero
        yawFrameToOverlay = (float)(RAD_TO_DEG * atan2(numerator,
        SMALL_ARBITRARY_FLOAT));
    }
    Test to see if the yaw value for the angle to the point to be displayed is within the field of view of the
    current frame. (FIG. 35, step 11740)
    // if in limits, calc differential yaw, scale and display bar
    if (((YawLimits == NORMAL_LIMITS)
        && ((yawFrameToOverlay >= yawMinFov) && (yawFrameToOverlay <= yawMaxFov))
        ) // note &&
        || ((YawLimits == WRAPPED_LIMITS)
        && ((yawFrameToOverlay >= yawMinFov) || (yawFrameToOverlay <=
        yawMaxFov))
        ) // note ||
    )
    {

```

If it is within the limits, calculate the offset from the middle pixel to the vertical line of pixels corresponding to the object's yaw angle relative to the current frame's yaw angle. (FIG. 35, step 11748)

```

    xPixel = (int)(xMidPixel + (xScale * tan(DEG_TO_RAD * (yawCurrentPt -
    yawFrameToOverlay))));

```

Finally, the pitch of the current frame is used to choose a point on the vertical line determined above. The calculation for CalcOverlayMarkers is described below. (FIG. 35, step 11750)

```

    pitchFrameToOverlay =
        CalcOverlayMarkers(&MarkerHalfWidth,
            &MarkerHalfHeight,
            m_pDoc->m_mta_file.m_Tombstone[index].XCtr,
            m_pDoc->m_mta_file.m_Tombstone[index].YCtr,
            ThisWndsFrame
        );

```

This program segment calculates the point on the vertical line determined by yaw angle from the current frame's centerline at which to project an x,y coordinate onto the current video frame. It presumes that the photographed space is planar and is not inclined with respect to the gravitational normal. It uses a CameraHeight setting, adjustable by the operator via the Action-Adjust Parameters dialog Camera Height Above Floor entry 10316 (FIG. 21).

```

// calculate angle between horizon and line from camera (at m_pDoc->m_tla_file.m_CameraHeight off
flat floor)
// to a particular overlay marker. Flat floor assumes z doesn't change too much.

```

```

float CMciWnd::CalcOverlayMarkers(int *pHalfWidth, int *pHalfHeight, int xCtrZone, int yCtrZone,
    unsigned short ThisWndsFrame)
{
    float AngleHorizonToMarkerOnFloor;
    double XYDistance;
    // d = x^2 + y^2
    XYDistance = (xCtrZone - (double)(m_pDoc->m_tla_file.get_x_data(ThisWndsFrame)))
        *(xCtrZone - (double)(m_pDoc->m_tla_file.get_x_data(ThisWndsFrame))) +
        (yCtrZone - (double)(m_pDoc->m_tla_file.get_y_data(ThisWndsFrame)))
        *(yCtrZone - (double)(m_pDoc->m_tla_file.get_y_data(ThisWndsFrame)));
}

```

-continued

```

if (XYDistance <= 0)
{
TRACE("CMciWnd::CalcOverlayMarkers, bad XYDistance after sqrt( )/n");
AfxMessageBox("CMciWnd::CalcOverlayMarkers, bad XYDistance before sqrt( )/n");
return 0;
}
else if (XYDistance == 0)
{
XYDistance = (double)SMALL_ARBITRARY_FLOAT; // let's not divide by zero.
}
else
{
// take square root
XYDistance = sqrt(XYDistance);
// for this part of calc, ignore pitch of camera, assume level
// calc angle between horizon and line from camera to center of dropped avi
AngleHorizonToMarkerOnFloor =
(float)(RAD_TO_DEG * atan2(m_pDoc->m_tla_file.m_CameraHeight,
XYDistance));
float SizeAdj = (float)(10 * m_pDoc->m_tla_file.m_CameraHeight / XYDistance);
*pHalfWidth = (int)(MAX_MARKER_WIDTH * SizeAdj);
*pHalfHeight = (int)(MAX_MARKER_HEIGHT * SizeAdj);
if (*pHalfWidth < MIN_MARKER_WIDTH)
{
*pHalfWidth = MIN_MARKER_WIDTH;
}
else if (*pHalfWidth > MAX_MARKER_WIDTH)
{
*pHalfWidth = MAX_MARKER_WIDTH;
}
if (*pHalfHeight < MIN_MARKER_HEIGHT)
{
*pHalfHeight = MIN_MARKER_HEIGHT;
}
else if (*pHalfHeight > MAX_MARKER_HEIGHT)
{
*pHalfHeight = MAX_MARKER_HEIGHT;
}
return AngleHorizonToMarkerOnFloor;
}
}

```

While the preferred embodiment of the invention has been described, it will be understood that numerous modifications and changes will occur to those skilled in the art. It is therefore intended by the appended claims to define the true scope of the invention. 40

What is claimed as new and desired to be secured by Letters Patent of the United States is:

[1. A spatially referenced photographic system comprising: 45

a data base containing plural images of objects and also containing information corresponding to said images defining the position at which each image was originally viewed and the orientation of the image with respect to that position; 50

image presentation and navigation means for displaying the images to a user and for facilitating the user in navigating among said images by receiving spatial movement commands from the user, as indicated by said spatial movement commands; 55

wherein said image presentation and navigation means includes means for displaying, along with an image, a view of the camera path and an indication of the camera position and orientation when the image was recorded; 60
 wherein camera position and orientation is indicated by a mark on the path oriented as the camera is oriented to point where the camera was pointing; and
 wherein the view is a plan view and wherein the mark bears an indication thereon of the yaw angle of the camera.] 65

[2. A spatially referenced photographic system comprising: 65

a data base containing plural images of objects and also containing information corresponding to said images defining the position at which each image was originally viewed and the orientation of the image with respect to that position;

image presentation and navigation means for displaying the images to a user and for facilitating the user in navigating among said images by receiving spatial movement commands from the user, as indicated by said spatial movement commands;

wherein said image presentation and navigation means includes means for displaying, along with an image, a view of the camera path and an indication of the camera position and orientation when the image was recorded; and

wherein a mark appears in said image of a location associated with another image such that the user may signal a desire to navigate forward to view said another image in a simple manner.]

[3. A spatially referenced photographic system in accordance with claim 2 wherein the path also bears an indication of the location of said another image.] 60

[4. A spatially referenced photographic system comprising: 65

a data base containing plural images of objects and also containing information corresponding to said images defining the position at which each image was originally viewed and the orientation of the image with respect to that position;

57

image presentation and navigation means for displaying the images to a user and for facilitating the user in navigating among said images by receiving spatial movement commands from the user, as indicated by said spatial movement commands; and

wherein said image presentation and navigation means provides the user with navigation controls for moving backward, in response to the actuation of which controls said means selects an image captured at a generally backward camera position having an orientation similar to that of an image the user is currently viewing.]

[5. A spatially referenced photographic system comprising:

a data base containing plural images of objects and also containing information corresponding to said images defining the position at which each image was originally viewed and the orientation of the image with respect to that positions;

image presentation and navigation means for displaying the images to a user and for facilitating the user in navigating among said images by receiving spatial movement commands from the user, as indicated by said spatial movement commands; and

wherein said image presentation and navigation means provides the user with navigation controls for rotating left or right, in response to the actuation of which controls said means selects an image captured at a generally left-rotated or right-rotated camera position having a position fore-, aft-, and side-to-side similar to that of an image the user is currently viewing.]

[6. A spatially referenced photographic system in accordance with claim 5 wherein the image which the user is currently viewing bears marks indicating left and right possible rotations which thereby indicate the general location of the viewpoint of said image captured at said generally left-rotated or right-rotated camera positions.]

[7. A spatially referenced photographic system in accordance with claim 6 wherein the user signals a desire to move generally left or right by mouse clicking on said indicating marks.]

[8. A spatially referenced photographic system comprising:

a data base containing plural images of objects and also containing information corresponding to said images defining the position at which each image was originally viewed and the orientation of the image with respect to that position;

image presentation and navigation means for displaying the images to a user and for facilitating the user in navigating among said images by receiving spatial movement commands from the user, as indicated by said spatial movement commands; and

wherein said image presentation and navigation means provides the user with navigation controls for moving forward and simultaneously rotating to the left or to the right, in response to the actuation of which controls said means selects an image captured at a generally forward camera position having an angular orientation rotated to the left or to the right of that of an image the user is currently viewing.]

[9. A spatially referenced photographic system comprising:

a data base containing plural images of objects and also containing information corresponding to said images defining the position at which each image was originally viewed and the orientation of the image with respect to that position;

58

image presentation and navigation means for displaying the images to a user and for facilitating the user in navigating among said images by receiving spatial movement commands from the user, as indicated by said spatial movement commands;

said image presentation and navigation means providing the user with navigation controls, in response to the actuation of which controls said presentation and navigation means selects an image captured at a position generally shifted from that of an image the user is currently viewing, as indicated by the user actuation of said controls.]

10. The spatially referenced photographic apparatus of claim 17 wherein the overlay item comprises a frame, wherein the computing device is configured to provide a new image corresponding to the overlay item in response to receiving signals indicating selection of the frame.

11. The spatially referenced photographic apparatus of claim 17 wherein the computing device is configured to provide a designation on at least one of the displayed image and a plan view of a position at which the displayed image was captured and a yaw orientation of the displayed image with respect to that position.

12. A spatially referenced photographic apparatus comprising:

a data base containing images of objects and information corresponding to the images, the information defining a position at which a respective image was captured and at least a yaw orientation of the respective image with respect to the position, wherein the information is derived from a camera position and orientation information automatically recorded substantially simultaneously with recording of the respective image;

a computing device in communication with the data base, the computing device configured to receive spatial movement commands and provide images for display in response to receiving the spatial movement commands via an interface;

wherein the computing device is configured to provide an overlay item projected onto a displayed image based on at least one of the respective images from the data base, the overlay item comprising an indication of a point or area of interest for the displayed image with respect to which one or more associated images are available in response to receiving signals indicating selection of the overlay item; and

wherein the computing device is configured to provide, along with the displayed image and the overlay item projected onto the displayed image, navigation controls for moving forward and simultaneously rotating to the left or to the right, the computing device configured to provide in response to actuation of the navigation controls a selected image captured at a generally forward camera position having an angular orientation rotated to the left or to the right of that of the displayed image.

13. A spatially referenced photographic apparatus comprising:

a data base containing images of objects and information corresponding to the images, the information defining a position at which a respective image was captured and at least a yaw orientation of the respective image with respect to the position, wherein the information is derived from a camera position and orientation information automatically recorded substantially simultaneously with recording of the respective image;

a computing device in communication with the data base, the computing device configured to receive spatial

movement commands and provide images for display in response to receiving the spatial movement commands via an interface;

wherein the computing device is configured to provide an overlay item projected onto a displayed image based on at least one of the respective images from the data base, the overlay item comprising an indication of a point or area of interest for the displayed image with respect to which one or more associated images are available in response to receiving signals indicating selection of the overlay item; and

wherein the computing device is configured to provide, along with the displayed image and the overlay item projected onto the displayed image, navigation controls for moving backward, the computing device configured to provide in response to actuation of the navigation controls a selected image captured at a generally backward camera position having an orientation similar to that of the displayed image.

14. A spatially referenced photographic apparatus comprising:

a data base containing images of objects and information corresponding to the images, the information defining a position at which a respective image was captured and at least a yaw orientation of the respective image with respect to the position, wherein the information is derived from a camera position and orientation information automatically recorded substantially simultaneously with recording of the respective image;

a computing device in communication with the data base, the computing device configured to receive spatial movement commands and provide images for display in response to receiving the spatial movement commands via an interface;

wherein the computing device is configured to provide an overlay item projected onto a displayed image based on at least one of the respective images from the data base, the overlay item comprising an indication of a point or area of interest for the displayed image with respect to which one or more associated images are available in response to receiving signals indicating selection of the overlay item; and

wherein the computing device is configured to provide, along with the displayed image and the overlay item projected onto the displayed image, navigation controls for rotating left or right, the computing device configured to provide in response to actuation of the navigation controls for rotating left or right an image captured at a generally left-rotated or right-rotated camera position having a position forward, backward, and side-to-side similar to that of the displayed image.

15. A spatially referenced photographic apparatus comprising:

a data base containing images of objects and information corresponding to the images, the information defining a position at which a respective image was captured and at least a yaw orientation of the respective image with respect to the position, wherein the information is derived from a camera position and orientation information automatically recorded substantially simultaneously with recording of the respective image;

a computing device in communication with the data base, the computing device configured to receive spatial movement commands and provide images for display in response to receiving the spatial movement commands via an interface;

wherein the computing device is configured to provide an overlay item projected onto a displayed image based on at least one of the respective images from the data base, the overlay item comprising an indication of a point or area of interest for the displayed image with respect to which one or more associated images are available in response to receiving signals indicating selection of the overlay item; and

wherein the displayed image with the overlay item projected onto the displayed image includes designations indicating left and right possible rotations corresponding to a general location of a viewpoint of an image captured at generally left-rotated or right-rotated camera positions.

16. The spatially referenced photographic apparatus of claim 15 wherein the computing device is configured to provide the image captured at generally left-rotated or right-rotated camera positions in response to receiving signals indicating selection of one of the designations.

17. A spatially referenced photographic apparatus comprising:

a data base containing images of objects and information corresponding to the images, the information defining a position at which a respective image was captured and at least a yaw orientation of the respective image with respect to the position, wherein the information is derived from a camera position and orientation information automatically recorded substantially simultaneously with recording of the respective image;

a computing device in communication with the data base, the computing device configured to receive spatial movement commands and provide images for display in response to receiving the spatial movement commands via an interface;

wherein the computing device is configured to provide an overlay item projected onto a displayed image based on at least one of the respective images from the data base, the overlay item comprising an indication of a point or area of interest for the displayed image with respect to which one or more associated images are available in response to receiving signals indicating selection of the overlay item; and

wherein the computing device is configured to provide, along with the displayed image and the overlay item projected onto the displayed image, navigation controls for moving forward and simultaneously rotating to the left or to the right, the computing device configured to provide in response to the actuation of the navigation controls an image captured at a generally forward camera position having an angular orientation rotated to the left or to the right of the displayed image.

18. The spatially referenced photographic apparatus of claim 17 wherein the computing device is configured to provide multiple images aligned in a panorama to provide a wider field of view.

19. The spatially referenced photographic apparatus of claim 17 wherein the computing device is configured to provide a plan view overlay item projected as a region onto the displayed image, the plan view overlay item comprising an indication of a point or area of interest on the plan view with respect to which one or more associated images are available, wherein the computing device is configured to provide a new image corresponding to the plan view overlay item in response to receiving signals indicating selection of the region.

20. The spatially referenced photographic apparatus of claim 17 wherein the computing device is configured to pro-

61

vide a new image corresponding to the overlay item in response to receiving signals indicating selection of the overlay item.

21. A spatially referenced photographic apparatus comprising:

a data base containing plural images of objects and also containing information corresponding to said images defining the position at which each image was originally captured and at least the yaw orientation of the image with respect to that position, wherein recorded information from which said position and yaw orientation information may be determined was automatically recorded substantially simultaneously with the recording of the image;

image presentation and navigation means for displaying the images to a user and for facilitating the user in navigating among said images by receiving spatial

62

movement commands from the user, as indicated by said spatial movement commands;
 said image presentation and navigation means providing to the user, for display in combination with the images and an overlay item, navigation controls, in response to the actuation of which controls said presentation and navigation means selects an image captured at a position generally shifted from that of an image the user is currently viewing, as indicated by the user actuation of said controls; and
 said image presentation and navigation means providing the user an overlay item projected onto the image the user is currently viewing, the overlay item comprising an indication of a point or area of interest for the image with respect to which one or more associated images are available in response to receiving signals indicating selection of the overlay item.

* * * * *