

FISCHER & KITTREDGE,

2 Sheets—Sheet 1.

Car Coupling.

No. 105,791.

Patented July 26, 1870.

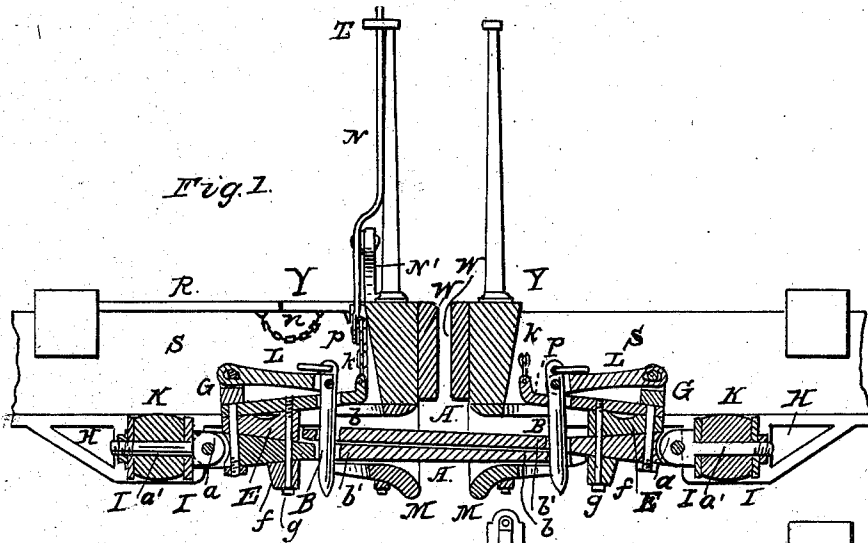

Fig. 1.

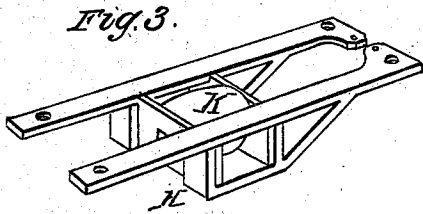

Fig. 3.

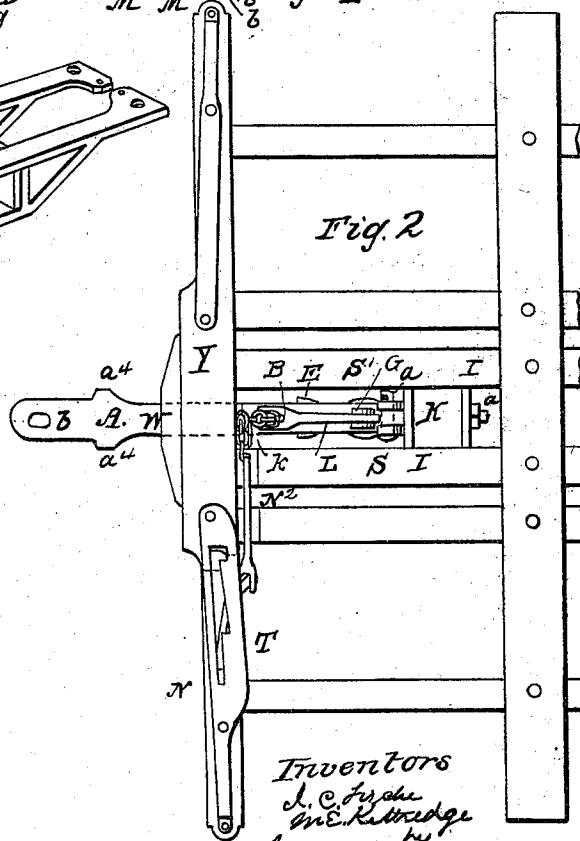

Fig. 2.

Witnesses
R. J. Campbell
J. C. Campbell

Inventors
J. C. Fischer
W. E. Kittredge
by
Mason & Hamerick

FISCHER & KITTREDGE.

Car Coupling.

No. 105,791.

Patented July 26, 1870.

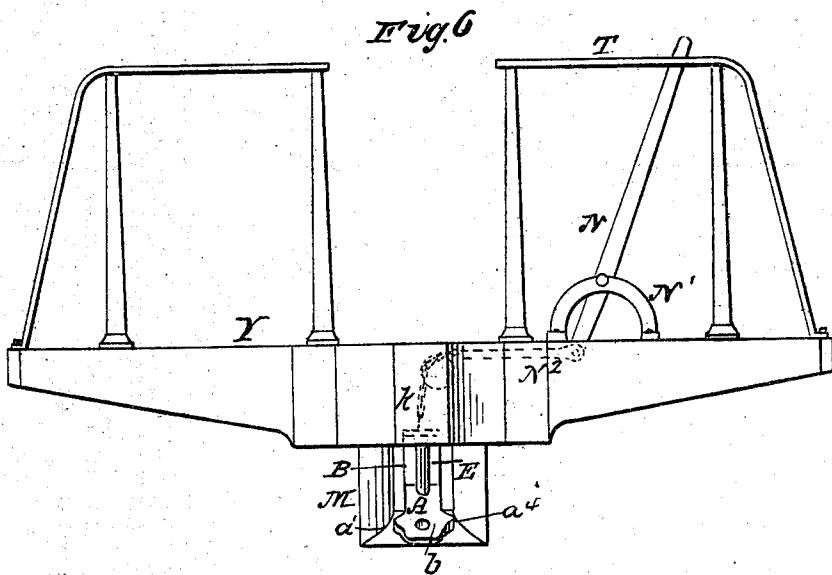
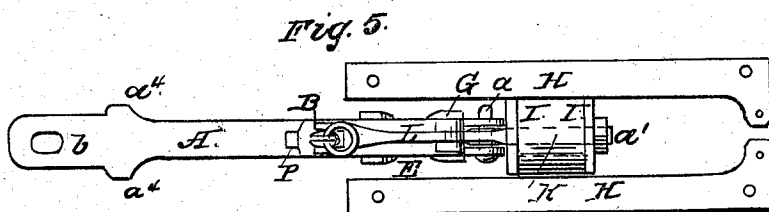
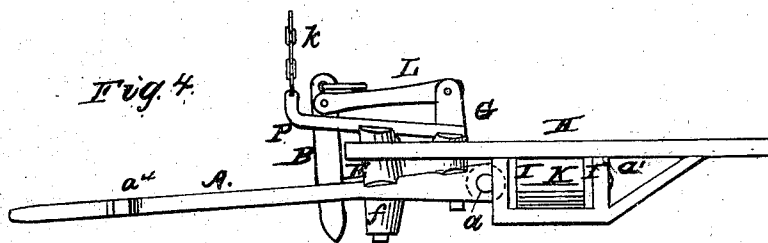

Witnesses
 R. J. Campbell
 & C. Campbell

Inventors.
 J. C. Fischer
 W. E. Kittredge
 by
 M. L. ...

United States Patent Office.

JEAN C. FISCHER AND WILLIAM E. KITTREDGE, OF MILWAUKEE, WISCONSIN.

Letters Patent No. 105,791, dated July 26, 1870.

IMPROVEMENT IN RAILWAY-CAR COUPLING.

The Schedule referred to in these Letters Patent and making part of the same.

To all whom it may concern:

Be it known that we, JEAN C. FISCHER and WILLIAM E. KITTREDGE, of Milwaukee, in the county of Milwaukee and State of Wisconsin, have invented certain Improvements in Car-Couplings; and we do hereby declare that the following is a full, clear, and exact description thereof, reference being had to the accompanying drawing making part of this specification, in which—

Figure 1, plate 1, is a central section, taken longitudinally and in a vertical plane through two platforms which are connected together, and also through the coupling devices.

Figure 2, plate 1, is a top view of a platform with floor removed, having our coupling applied to it.

Figure 3, plate 1, is a perspective view of one of the combined staples and spring pockets.

Figure 4, plate 2, is a side view of the coupling device for one platform.

Figure 5, plate 2, is a top view of the same.

Figure 6, plate 2, is a front elevation of a platform and its coupling device.

Similar letters of reference indicate corresponding parts in the several figures.

This invention relates to certain novel improvements on couplings for cars, wherein we combine, in a manner hereinafter described, the following important and useful features, to wit:

First, a buffer spring, which is applied in a pocket formed within a substantial wrought-metal staple or frame, which is secured to two longitudinal beams of the platform, said spring being adapted to relieve shocks and concussions caused by longitudinal motion of the cars.

Second, a coupling draw-bar, which is connected to the said spring at one end, and adapted for receiving through its opposite flanged end a coupling-pin, such bar being constructed on its lower side with a strong abutment for receiving and resisting end thrusts of a corresponding bar on another car, and on its upper side with an overhanging perforated guide for the coupling-pin, which latter passes through the guide and through a hole made through the bar directly beneath it, and is connected by a link to the heel of the guide, and to a lifting device, by means of a chain, as will be hereinafter explained.

Third, coupling draw-bars, which are broad, flat bars, constructed so that when coupled they will lie one over the other, and allow free lateral and vertical play of the ends of the cars, and which are perforated coupling-pins through them back of the front beams of the platforms, as will be hereinafter explained.

To enable others skilled in the art to understand

our invention, we will explain its construction and operation.

The platforms of the cars may be constructed in the usual well-known manner. We prefer to elevate the same, so as to bring the front cross-beam or buffer-beam Y level, or nearly so, with the longitudinal floor timbers of the car-body, and also to so construct the buffer-beams Y that the platforms can be coupled very close together in a train, and proper motion allowed for turning curves.

In the center of the buffer-beam Y a friction-plate, W, is secured, below which is the outwardly-flaring mouth-piece or coupling-box M, bolted rigidly to the lower sides of the platform timbers, and made so as to allow free lateral and vertical play of the cars when coupled.

Behind the mouth-piece M is a frame, H, which is bolted fast to the longitudinal platform timbers, and constructed so as to receive and form guides for two vertical transverse compression-plates, I, between which a rubber block, K, is compressed and confined by means of an eye-bolt, a.

To the front end or eye of the bolt the rear bifurcated end of the coupling draw-bar A is connected by means of a horizontal transverse pivot, a, which will allow lateral as well as vertical play to the free end of said draw-bar.

The compression-plates I I are allowed to slide freely, so as to cause the spring to modify shocks of traction as well as thrust.

Each coupling draw-bar A is a flat, broad bar, perforated vertically at b and b', for the coupling-pins B B, made thicker at its rear end than at its front end, and provided with fins or flanges on its edges near its front end.

The front end is rounded laterally, and slightly beveled vertically. The holes b b' through this bar are slightly oblong, and, when two cars are brought together in position for being coupled, the holes of one bar A are directly over the holes of the other bar, so that the bars can be coupled by pins B B, passed through these holes b b'.

On the upper side of each draw-bar A, near its pivoted end, a strong abutment, E, is bolted, and on the lower side of the bar, directly beneath the block or abutment E, an abutment, F, is secured.

The bolts g G are used, as shown in fig. 1, to secure the abutments E E to the draw-bar.

The bolt G is constructed with a slotted and perforated head, to which is pivoted the rear end of a stiff link, L, the front end of which has the coupling-pin B pivoted to it, as shown in the drawing.

The two abutments E E are intended to operate, in

conjunction with corresponding abutments E E on the upper and lower sides of the opposite draw-bar A, as means for resisting end-thrusts of these two bars.

To this end the said abutments should be so arranged, relatively to the ends of the draw-bars, that the pins B B can be dropped through their respective holes *b b'*, through both draw-bars, when the ends of the latter impinge against said abutments.

To the upper side of each abutment E, and bolted thereto, is a coupling-pin guide, P, which is a narrow plate, directed forward and upward, and terminating anteriorly in an eye for having attached to it a lifting-chain, *k*.

Just in rear of this chain-eye an oblong hole is made vertically through the guide P, directly over the hole *b'*, which is through the bar A, as shown in fig. 1. This hole through the guide receives the coupling-pin B through it, which pin, as before stated, is pivoted by a transverse pivot to the front end of the vertically vibrating link or guard L.

The chain *k* is carried up and over a pulley at back of beam Y, and attached to one end of a horizontal rod, N², which lies in a transverse groove beneath the floor of the platform, immediately behind the beam Y, as shown in fig. 2.

To the outer end of the rod N² the lower end of a laterally vibrating hand-lever, N, is pivoted, which lever has its fulcrum on standard N¹, and is carried up through an oblong slot made through the guard-rail T.

One of the edges of said slot is notched, as shown in fig. 2, to receive and hold the N in place when it is adjusted for holding up the coupling draw-bar.

The upper end of each coupling-pin B has a ring applied to it by which it is handled, and the lower end of such pin is rounded and tapered, as shown in the drawing. We case-harden these pins to prevent them from rapid wear, and to render them easy to lift up or uncouple.

The fins or wings *a' a'*, on the edges of each coupling draw-bar, serve, in connection with the rear contracted ends of the mouth-piece M of an opposite car, to guide the bar centrally to its place beneath the coupling, and, at the same time, they allow lateral motion of the cars without causing the draw-bar to bind in the mouth-piece.

A coupling constructed as above described allows very little slack or lost longitudinal motion in cars coupled together, inasmuch as the draw-bars transmit such all-endwise motion directly to the springs, both in drawing and thrusting, and operate in effect almost as though a single draw-bar was used, connected at both ends to springs; consequently all unpleasant and injurious shocks and jerks are obviated.

Having described our invention,

What we claim as new, and desire to secure by Letters Patent, is—

1. The overlapping draw-bars A A, perforated at *b b*, and furnished with abutments E E, and guides P P, in combination with coupling-pins B B, and springs K, which springs are fitted in housings H H, and connected by pivots *a a* to the draw-bars, the said draw-bars, housings, and springs, being arranged substantially in the manner described.

2. The lifting and guiding-plates P P, in combination with the overlapping shouldered and perforated draw-bars A A, pins B, and links L, substantially in the manner described.

3. The combination of the buffers W W, draw-heads M M, overlapping pivoted and shouldered draw-bars A A, springs K K, guiding and lifting-plates P P, and hinged pins B B, substantially as described.

JEAN C. FISCHER.
WILLIAM E. KITTREDGE.

*Witnesses:

ANDREW McELROY,
HENRY DANA.