

(Model.)

L. A. BROWN.
SEAL LOCK.

No. 388,258.

Patented Aug. 21, 1888.

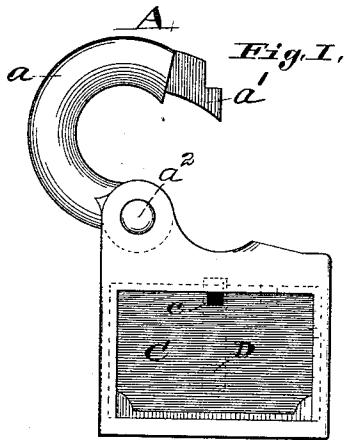

Fig. 1,

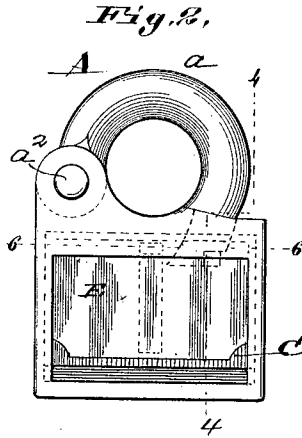

Fig. 2,



Fig. 7,

Fig. 3,

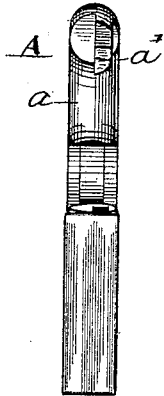

Fig. 5,

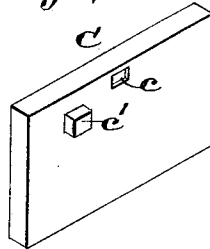

Fig. 4,

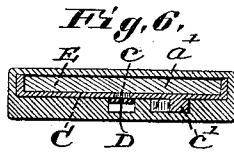
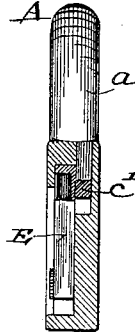

Fig. 6,

Attest:
G. W. Sanford,
B. J. Rep.

Inventor,
Lewis A. Brown,
by C. P. Moody,
att'y.

UNITED STATES PATENT OFFICE.

LEWIS A. BROWN, OF ST. LOUIS, MISSOURI.

SEAL-LOCK.

SPECIFICATION forming part of Letters Patent No. 338,258, dated August 21, 1888.

Application filed April 6, 1888. Serial No. 269,883. (Model.)

To all whom it may concern:

Be it known that I, LEWIS A. BROWN, of St. Louis, Missouri, have made a new and useful Improvement in Seal-Locks, of which the following is a full, clear, and exact description.

I have heretofore, March 9, 1888, Serial No. 266,725, filed an application for Letters Patent for an improvement in seal-locks, wherein that part of the padlock or other lock or seal which needs to be reached to effect the unlocking of the lock-bar, bolt, &c., is adapted to be shielded by a part which in use is slipped or passed or moved in the lock or seal so as to come over the part in question, and in that position to be locked, and thus for the time being prevent access to that part. The shield in turn is guarded by a seal, such as a glass plate, and in such manner as to necessitate the breaking of the frangible plate in order to reach the shield-fastening. Thus the presence of the plate unbroken is evidence that the lock has not been opened.

The present improved construction is related to the one referred to. In said original construction the padlock-bow, or whatever lock-bar is used, is adapted to be locked by means of a part which is separate from the shield, and which, when the shield is in position, is covered by the shield, and in order to reach such part the shield must first be removed. In the present construction there is no such separate part, and the padlock-bow, &c., is adapted to be connected directly with the so-called "shield," substantially as hereinafter specified and claimed and illustrated in the drawings hereto annexed and made part of this specification, in which—

Figure 1 is a front elevation of a padlock having the improvement embodied therein, the bow being raised, the seal being omitted; Fig. 2, a front elevation of the padlock locked; Fig. 3, an edge elevation of the padlock, the bow being opened; Fig. 4, a section on the line 4 4 of Fig. 2; Fig. 5, a view in perspective of the locking-plate; Fig. 6, a horizontal section on the line 6 6 of Fig. 2, and Fig. 7 is a detail view of the engaging end of the bow.

The same letters of reference denote the same parts.

A represents the padlock used to illustrate

the application of the improvement. Its construction is of the ordinary kind otherwise than as modified by the embodiment therein of the improvement.

C represents the part corresponding to what is in the original construction termed the "shield," but which is now styled the "locking-plate." It is adapted to be held and moved upward and downward in the padlock-case and to be fastened in its up position, substantially as is the shield in the original construction—that is, the plate C is perforated or recessed at *c*, and when the locking-plate is moved to position to effect the locking of the padlock-bow *a* a spring-catch, D, behind the locking-plate springs forward and engages in the perforation *c*, and thereby locks the plate C in position. The locking-plate C and the padlock-bow *a* are relatively so constructed as to cause them, when the locking-plate is in its up position and the bow is in its closed position, as in Fig. 2, to become interlocked, and so that the bow cannot be disengaged to be opened without first withdrawing the locking-plate into its down position. To this end and as the most desirable construction the locking-plate is provided with a projection, *c'*, and the bow *a* is provided with a projection, *a'*, and when the locking-plate is raised and the bow closed the bow projection comes behind (*i. e.*, to the left, as shown in Fig. 2) the locking-plate projection, and the bow is thus prevented from turning on its pivot *a*².

E represents the seal employed to guard the locking-plate. It is adapted to coact with the locking-plate and to prevent access to the spring-catch D in manner similar to that in which the seal is made to co-operate with the shield in the original construction—that is, to unlock the padlock the seal must be removed, which can be done only by breaking it. Then the spring-catch D is pressed backward, and thereby detached from the locked plate. The locking-plate, now being free, is drawn downward into the position of Fig. 1, which movement of the locking-plate causes the projection *c'* to be withdrawn from in front of the bow projection *a'* and the bow to be free to be turned on its pivot.

The present improvement can be applied to many other forms of locks—to trunk-locks, for

example. In such locks it is desirable for the locking-bolt (the part corresponding to the padlock-bow in the present illustration) to be moved in a right line, say upward and downward. In such a case the seal-lock may be contrived to have the locking-plate move to the right and left, and thereby engage with and be disengaged from a projection upon the locking-bolt corresponding to the bow projection *a'*.
10 The projection *c'* in the present illustration is shown upon the back side of the locking-plate.

I claim—

The combination of the lock-case, the bow having the projection *a'*, the locking-plate having the perforation *c* and the projection *c'*, and the seal and the spring-catch D, substantially as described.

Witness my hand this 28th day of March, 1888.

LEWIS A. BROWN.

Witnesses:

C. D. MOODY,
JAS. W. ALLEN.