

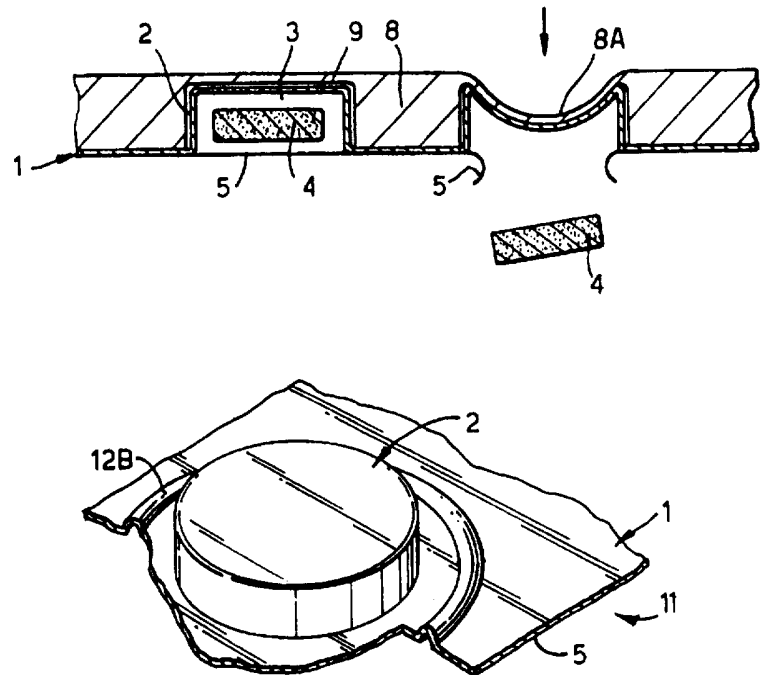

INTERNATIONAL APPLICATION PUBLISHED UNDER THE PATENT COOPERATION TREATY (PCT)

<p>(51) International Patent Classification ⁶ : B65D 75/34</p>	<p>A1</p>	<p>(11) International Publication Number: WO 97/20754 (43) International Publication Date: 12 June 1997 (12.06.97)</p>
<p>(21) International Application Number: PCT/EP96/05536 (22) International Filing Date: 6 December 1996 (06.12.96) (30) Priority Data: 9525065.0 7 December 1995 (07.12.95) GB (71) Applicant (for all designated States except US): SMITHKLINE BEECHAM PLC [GB/GB]; New Horizons Court, Brentford, Middlesex TW8 9EP (GB). (72) Inventor; and (75) Inventor/Applicant (for US only): FLEWITT, Harry [GB/GB]; SmithKline Beecham, SB House, Great West Road, Brentford TW8 9EP (GB). (74) Agent: WALKER, Ralph, Francis; SmithKline Beecham, Corporate Intellectual Property, Two New Horizons Court, Brentford, Middlesex TW8 9EP (GB).</p>		<p>(81) Designated States: AL, AM, AT, AU, AZ, BA, BB, BG, BR, BY, CA, CH, CN, CU, CZ, DE, DK, EE, ES, FI, GB, GE, HU, IL, IS, JP, KE, KG, KP, KR, KZ, LC, LK, LR, LS, LT, LU, LV, MD, MG, MK, MN, MW, MX, NO, NZ, PL, PT, RO, RU, SD, SE, SG, SI, SK, TJ, TM, TR, TT, UA, UG, US, UZ, VN, ARIPO patent (KE, LS, MW, SD, SZ, UG), Eurasian patent (AM, AZ, BY, KG, KZ, MD, RU, TJ, TM), European patent (AT, BE, CH, DE, DK, ES, FI, FR, GB, GR, IE, IT, LU, MC, NL, PT, SE), OAPI patent (BF, BJ, CF, CG, CI, CM, GA, GN, ML, MR, NE, SN, TD, TG).</p> <p>Published With international search report. Before the expiration of the time limit for amending the claims and to be republished in the event of the receipt of amendments.</p>

(54) Title: REINFORCED BLISTER PACK



(57) Abstract

A blister pack wherein the material between the blisters (2) is reinforced (8, 12B) to confer rigidity relative to flexing deformation of the blister pack. The reinforcement (8, 12B) may take the form of a reinforcing slab or sheet (8), or ribs (12B) in the blister pack material. The invention facilitates handling by users with weak or deformed hands.

FOR THE PURPOSES OF INFORMATION ONLY

Codes used to identify States party to the PCT on the front pages of pamphlets publishing international applications under the PCT.

AM	Armenia	GB	United Kingdom	MW	Malawi
AT	Austria	GE	Georgia	MX	Mexico
AU	Australia	GN	Guinea	NE	Niger
BB	Barbados	GR	Greece	NL	Netherlands
BE	Belgium	HU	Hungary	NO	Norway
BF	Burkina Faso	IE	Ireland	NZ	New Zealand
BG	Bulgaria	IT	Italy	PL	Poland
BJ	Benin	JP	Japan	PT	Portugal
BR	Brazil	KE	Kenya	RO	Romania
BY	Belarus	KG	Kyrgystan	RU	Russian Federation
CA	Canada	KP	Democratic People's Republic of Korea	SD	Sudan
CF	Central African Republic	KR	Republic of Korea	SE	Sweden
CG	Congo	KZ	Kazakhstan	SG	Singapore
CH	Switzerland	LI	Liechtenstein	SI	Slovenia
CI	Côte d'Ivoire	LK	Sri Lanka	SK	Slovakia
CM	Cameroon	LR	Liberia	SN	Senegal
CN	China	LT	Lithuania	SZ	Swaziland
CS	Czechoslovakia	LU	Luxembourg	TD	Chad
CZ	Czech Republic	LV	Latvia	TG	Togo
DE	Germany	MC	Monaco	TJ	Tajikistan
DK	Denmark	MD	Republic of Moldova	TT	Trinidad and Tobago
EE	Estonia	MG	Madagascar	UA	Ukraine
ES	Spain	ML	Mali	UG	Uganda
FI	Finland	MN	Mongolia	US	United States of America
FR	France	MR	Mauritania	UZ	Uzbekistan
GA	Gabon			VN	Viet Nam

Reinforced Blister Pack.

This invention relates to a packaging system, particularly for solid unit dosage forms such as pharmaceutical tablets, capsules, pills etc. (herein individually and collectively termed "tablets").

5 Blister packs are commonly used for containing tablets. Blister packs generally comprise a pattern of blisters formed in a sheet of substantially impermeable deformable plastics material, each blister defining a cavity for the containment of a tablet, the open face of the blister being closed with a film cover, usually a thin, tearable metal foil or a peel-off film. The film cover can either be
10 easily ruptured, or the film can be easily peeled away from the blister. In use either the blister is compressibly deformed so as to force the tablet therein out through a rupturable film, or else the film is peeled off and the tablet is removed from the cavity. Generally the deformable material is a stiff but relatively flexible material such as a plastics material or a plastics material laminate or plastics material metal
15 foil laminate.

Known blister packs have the disadvantage that they are difficult for users with weak or deformed hands, e.g. arthritic patients to use, because the plastic material is relatively flexible and therefore difficult to exert a compressive force against and tends to deform by flexing if pressure is applied to a blister to force a
20 tablet out through a rupturable film. Also they easily crumple, curl or fold during use and thus become of untidy appearance. It is an object of the present invention to at least partly provide a solution to these problems.

According to the invention a blister pack is provided wherein the material between the blisters is reinforced to confer rigidity relative to flexing deformation
25 of the blister pack.

The reinforcement according to the invention is such that the application of compressive force to a blister sufficient to force a tablet contained therein out through a rupturable film cover over the open face of the blister is insufficient to cause the material between the blisters to significantly deform.

By "significantly deform" it is understood that the pack will inevitably to some extent deform, but that the extent of deformation will be such that a user forcing a tablet out will experience sufficient rigidity of the pack to be able to force the tablet out against this rigidity, without the pack crumpling or bending by a flexing of the material between the blisters to an extent such that the blister pack crumples or bends rather than the contents of the blister being forced out. The term "flexing" herein denotes inter alia bending and folding of the pack out of the plane of the blister pack. The degree of reinforcing necessary to achieve this is determined in each case by practical considerations. Also by "significantly deform" is understood that the material between the blisters may temporarily deform elastically under the pressure applied to force the tablet out, but that the material will return substantially to its undeformed shape on release of the pressure, such that the reinforced pack does not become curled up through use. The term "rigid" herein includes more rigid against out of the plane of the slab folding and bending deformation under the application of folding or bending forces, relative to the relative flexibility of the thin sheet materials generally used for blister packs.

By means of the invention the blister pack is provided with sufficient rigidity that a user with weak or deformed hands can easily apply a compressive force to the blister against the rigidity, which is considerably easier than applying a compressive force to a blister pack made of flexible plastics material of known type, and also there will be less likelihood of the user dropping the pack during use.

In the invention the material is preferably reinforced by the combination of the blister pack, which may be a conventional known blister pack as presently widely used commercially, with a rigid support, alternatively or additionally by the introduction of structural elements such as ribs into the material between the blisters in the pack, alternatively the material between the blisters may be reinforced by a general thickening of the material to impart rigidity.

A first embodiment of the invention provides a combination of a blister pack and a substantially rigid reinforcing support for the blister pack, the support comprising a substantially planar slab of substantially rigid material having a pattern of holes passing completely through the thickness of the slab, the said holes being in

a pattern corresponding to the blisters of the blister pack, the blister pack being in contact with the support such that each blister fits into a hole, each blister being accessible to a user via the hole.

In this embodiment the user can apply compressive pressure to the blister via the hole and thereby force a tablet out through a rupturable film cover over the open face of the blister. This first embodiment may also be used with blister packs having a peel off film over the open face of the blister.

In this first embodiment the support is preferably stuck to the deformable material between the blisters, so as to prevent separation of the blister pack from the support during the application of compressive pressure to the blister. This first embodiment may also be used with blister packs having a peel off film over the open face of the blister, and by sticking of the material to the support, separation of the blister pack from the support during peeling off can be avoided. The rear face opening of the holes, i.e. on that face of the slab facing away from the film cover of the blisters, may be closed with a flexible film, e.g. to impart a neat appearance or to protect the blisters, which may be forced out by pressure on the flexible film.

A second embodiment of this invention provides a combination of a blister pack and a substantially rigid support for the blister pack, the support comprising a substantially planar slab of substantially rigid material having a pattern of holes in its surface, which pass only partly through the thickness of the slab, the said holes being in a pattern corresponding to the blisters on the blister pack, the blister pack being in contact with the holder such that each blister fits into a hole, the blister pack having a peel-off film cover over the open face of the blister.

In this second embodiment the support is preferably stuck to the deformable material between the blisters, for the same reasons as for the first embodiment. Again, if the holes pass all the way through the slab, the rear face opening of the holes, i.e. on that face of the slab facing away from the film cover of the blisters, may be closed with a flexible film.

A third embodiment of this invention provides a combination of a blister pack and a substantially rigid but support for the blister pack, the support comprising a substantially planar slab of substantially rigid material having a pattern

of holes in its surface, which pass only partly through the thickness of the slab, the said holes being in a pattern corresponding to the blisters on the blister pack, the blister pack being in contact with the holder such that each blister fits into a hole, the blister pack having a rupturable film cover over the open face of the blister, the
5 material of the slab being compressibly deformable at least in the region of the holes, such that pressure can be applied to the slab on the reverse face to that on which the holes open, so as to thereby deform the said material and apply pressure to the blister, and so to force the tablet out through the rupturable film cover.

In this third embodiment the support is preferably stuck to the deformable
10 material between the blisters, for the same reasons as for the first embodiment.

The said holes may be substantially the same size and shape as the external perimeter of the blisters.

A fourth embodiment of the invention provides a combination of a blister pack and a substantially rigid reinforcing support for the blister pack, the support
15 comprising a substantially planar slab of substantially rigid material having a pattern of holes passing completely through the thickness of the slab, the said holes being in a pattern corresponding to the blisters of the blister pack, the blister pack being in contact with the support such that each blister fits over a hole, each blister having a rupturable film cover over its open face, the film cover facing the upper surface of
20 the slab, the slab having a thickness such that the blister may be compressibly deformed when the pack is laid upon a surface so as to force the tablet out through the film and through the hole.

By means of this embodiment the blisters may be pressed against the rigidity of the support, and the tablets forced out. The rigidity facilitates use by those with
25 weak or deformed hands. If the slab is made thick enough the combination may be laid on a surface such as a table with the blisters uppermost, and the tablets may be forced out through the holes. The combination may then be lifted up such that the tablets are left on the surface, further facilitating access to the tablets. This may be particularly advantageous for small tablets, particularly those having a thickness less
30 than the thickness of the slab, which are otherwise easy to drop.

There may be a further support slab having suitably positioned holes therein, to allow access to the blisters, mounted against the material of the blister pack, on the opposite surface to that on which the rupturable film is.

In this fourth embodiment the support is preferably stuck to the deformable material between the blisters, for the same reasons as for the first embodiment.

When access to the blisters is via holes in supports as described above, the holes may be suitably shaped and/or profiled to guide the thumb or fingers of the user toward the blister. In this way use of the packaging system by those who are visually impaired may be facilitated.

The support in the first, second, third and fourth embodiments may suitably comprise a thick slab in the form of a sheet of rigid plastics material, or a rigid cellular plastics material structure, a foamed or expanded plastics material, thick or corrugated cardboard, laminates e.g of plastics sheet materials and card, or plastics sheet materials and foamed plastics etc. Other ways of making a rigid support will be apparent to those skilled in the art. The support in these embodiments of the invention may comprise a part of a package for the blister pack, e.g a box or carton in which one or more blister packs are contained.

The invention also provides a support when provided for a combination as disclosed above, and a method of construction of such a combination which comprises combining a blister pack as described with a support as described.

In a fifth embodiment of this invention the deformable material between blisters may be rendered rigid by the formation therein of structural strengthening ribs.

Such strengthening ribs may for example be in the form of thickened areas of the said material, or corrugations therein. The ribs may be of any convenient shape, for example linear, in a grid pattern, or surrounding the blister, e.g. in the form of a ring around each blister. The ribs may project from the same face of the material as does the blister. Alternately, particularly in the case where the open face of the blister is closed by a rupturable film, the ribs may project from the face of the material which is covered with the film. In this way if the blister pack is laid flat

on a surface such as a table the ribs create a space beneath the blister pack, which enable the user to compressibly deform the blister against its rigidity and force a tablet through the film and out of the blister. If the said space is wide enough the tablet can thereby be pressed out onto the surface, so as to be left there when the deformed pack is lifted away.

In this way use of the pack by those with weak or deformed hands is facilitated. Also the ribs in the material may be so shaped or aligned etc. to guide the thumb or fingers of the user toward the blister, and may be combined with for example Braille symbols embossed on the material. In this way use of the blister pack by the visually impaired is facilitated.

When in this invention the material between the blisters is reinforced by a general thickening of the material to impart rigidity, the material between the blisters may be the same material as is normally used for making blister packs, e.g. a flexible plastics material, but made thicker, e.g. 50% thicker or twice as thick as is conventionally used. This method is not preferred however as it can result in blisters which are difficult to deform by pressure, or alternatively require areas of thinner material to be used at places where there are blisters. Also the materials from which blister packs are made can be quite expensive, e.g. needing to provide protection against moisture and air etc. over a long storage period, whereas the materials used for the above described supports can be very cheap.

The blister pack incorporated in the combination packaging system of this invention may be of generally conventional construction. The blisters may be any convenient shape and size to suit the tablets for which they are to be used, as conventional. The packaging system of the invention is suitable for use with all kinds of tablets, and may for example be used with the tablets disclosed in EP 0055009A which are specifically intended for use by patients with weak or deformed hands, because such tablets tend to come to rest in a tilted position, relatively easy to grasp.

The support and blister pack discussed above may be of any convenient shape, but a preferred shape is rectangular, so as to enable the combination of

support and blister pack to be conveniently contained in a box. Alternatively for example the support and blister pack may be circular, or of other shapes.

The blister pack of the invention, and the reinforcing slab may be made out of entirely conventional materials and by entirely conventional processes.

5 The invention will now be described by way of example only with reference to the accompanying drawings.

Fig. 1 shows the construction of a conventional blister pack, in cross section

10 Fig. 2 shows the construction of another type of conventional blister pack, in section

Fig. 3 shows part of a packaging system of the first embodiment of this invention in a perspective sectional view

Fig. 4 shows a packaging system of the second embodiment of this invention, in section

15 Fig. 5 shows a packaging system of the third embodiment of this invention, in section

Fig. 7 shows two types of packaging systems of the fifth embodiment of this invention in part-sectioned perspective view.

Referring to Fig. 1, a conventional blister pack comprises a sheet of
20 substantially impermeable plastics material 1 in which are formed blisters 2, each blister 2 defining a cavity 3 for the containment of a tablet 4 therein. The open face of the cavity 3 is closed by a rupturable metal foil cover 5, thin enough that when the blister 2 is deformed by compressive pressure as at blister 2A the tablet 4 can be forced out for use through the foil cover 5 as this tears.

25 Referring to Fig. 2, another type of conventional blister pack is shown, in which parts corresponding to Fig. 1 are numbered correspondingly. In the blister pack of Fig. 2 the film 5 is a film which can be easily peeled away from the sheet 1 as shown at 5A, to allow the tablet 4 to be removed for use. The film 5 is divided by cuts at points 6 to allow a small patch of the film 5 to be peeled off as shown at
30 5A to open a single cavity, to enable the tablet 4 to be removed.

Referring to Fig. 3 a combination of a blister pack 7 and a substantially rigid support 8 is shown. The blister pack 7 may be either of the type shown in Fig. 1 or Fig. 2. The support 8 comprises a substantially planar slab made for example of corrugated cardboard, expanded polystyrene or a plastic material cellular structure etc. Passing completely through the thickness of the slab 8 is a pattern of holes 9, the pattern of the holes 9 corresponding to the pattern of the blisters 2 in the blister pack 7, such that when the plastic material 1 of the blister pack 7 is in contact with the slab 8, each blister 2 fits into a hole 9. The material 1 is stuck to the surface of the slab 8 by means of a suitable adhesive (not shown). As the holes 9 pass completely through the slab 8, the blisters 2 are accessible via the hole 9 in which they fit.

The combination can be used in two ways depending upon whether the blister pack is of the type shown in Fig. 1 or Fig. 2. If as shown in Fig. 1, which is illustrated in Fig. 3, compressive pressure can be applied to the blister as shown by the arrow in Fig. 3 to deform the blister 2A as shown and force the tablet 4 out through the foil 5. The substantially rigid slab 8 prevents the blister pack 7 from crumpling during use and adopting an untidy appearance.

If the blister pack is as shown in Fig. 2, then film may be simply peeled back as shown in Fig. 2 with the blister pack 7 in-situ in the slab 8. The slab 8 again eases this operation for users with weak or deformed hands, and prevents the blister pack 6 from crumpling during use.

Referring to Fig. 4 a combination of a blister pack 7 and a substantially rigid slab 8 is shown, generally similar in construction to that of Fig. 3, except that holes 9 do not pass completely through the slab 8, but only part way through, so as to form cavities in which the blisters 2 fit. In this combination the blister pack 7 is of the type shown in Fig. 2. The plastics material 1 between the blisters 2 is again stuck to the slab 8, and the film 5 can be peeled off as shown to allow removal of the tablet 4.

The slab 8 again eases the use of the blister pack by those with weak or deformed hands.

Referring to Fig. 5 a combination of a blister pack 7 and a substantially rigid slab 8 is shown, generally similar in construction to that of Fig. 4, such that holes 9

do not pass completely through the slab 8, but only part way through, so as to form cavities in which the blisters 2 fit. In this combination the blister pack 7 is of the type shown in Fig. 1. The plastics material 1 between the blisters 2 is again stuck to the slab 8. The material of the slab 8 is compressibly deformable at least in the region of the holes 9, i.e. at points 8A such that pressure can be applied to the slab 9 in this region on the reverse face to that on which the holes 9 open, i.e. at the point shown by the arrow in Fig 5, so as to thereby deform the said material and force the tablet 4 out through the rupturable film cover 5.

The slab 8 again eases the use of the blister pack by those with weak or deformed hands.

Referring to Fig. 6 a combination of a blister pack 7 and a substantially rigid reinforcing support for the blister pack is shown. The support comprises a substantially planar slab 8 of substantially rigid material having a pattern of holes 9 passing completely through the thickness of the slab 8. The holes 9 are in a pattern corresponding to the blisters 2 of the blister pack 7, the blister pack 7 being in contact with the support 8 such that each blister 2 fits over a hole 9. Each blister 2 has a rupturable film cover 5 over its open face, the film 5 cover facing the upper surface of the slab 8. The slab 8 has a thickness such that the blister 2 may be compressibly deformed, as shown at 2A, so as to force the tablet 4 out through the film 5 and through the hole 9.

By means of this embodiment the blisters 2 may be pressed against the rigidity of the support 8, and the tablets 4 forced out. The slab is made thick enough as shown in Fig. 6 the combination may be laid on a surface 10 such as a table with the blisters 2 uppermost, and the tablets may be forced out through the holes 9 to fall onto the surface 10. The combination may then be lifted up such that the tablets 4 are left on the surface 10, further facilitating access to the tablets.

A further support slab 8A having suitably positioned holes 9A therein, to allow access to the blisters 2, may be mounted against the material of the blister pack 1, on the opposite surface to that on which the rupturable film 5 is.

Referring to Fig. 7A, 7B and 7C, three blister packs 11 (generally) are shown, in which the plastics material 1 between blisters 2 is rendered rigid by the

formation therein of reinforcing ribs 12A, 12B, 12C bulging out of the plastics material 1. In Figs 7A and 7B the ribs 12A, 12B bulge out in the same direction as the blisters 2, and in Fig. 7C they bulge out in the opposite direction. In Fig. 6A the blisters 2 are generally lozenge shaped, in Fig 6 B the blister 2 is circular. In
5 Fig 6A ribs 12A are linear structures, disposed between the blisters 2 in a grid fashion. In Fig. 6B the rib 12B is formed as a ring around the blisters 2.

In each case the ribs 12A, 12B, 12C render the blister pack 11 sufficiently rigid that when the blister pack is of the type shown in Fig. 1, compressive pressure is applied to a blister 2 so as to force a tablet 4 (not shown in Fig. 6) out through
10 the film cover 5 the blister pack 10 does not significantly deform. The blister pack 11 could alternatively have a film cover 5 which can be peeled off in the general manner shown in Fig 2. This reinforcement eases the use of the blister pack 11 by those with weak or deformed hands.

In Fig. 7C the ribs 12C enable the blister pack 11 to be placed upon a
15 surface 13, with a space 14 thereby formed beneath the pack 11. The blister 2 can be compressibly deformed as shown at 2A so as to force the tablet 4 out through the foil cover 5 onto the surface 13. The blister pack 11 may then be lifted from the surface 13 to leave the tablet 4 thereon.

Claims:

1. A blister pack wherein the material between the blisters is reinforced to confer rigidity relative to flexing deformation of the blister pack.
2. A blister pack according to claim 1 wherein the reinforcement is such that
5 the application of compressive force to a blister sufficient to force a tablet contained therein out through a rupturable film cover over the open face of the blister is insufficient to cause the material between the blisters to significantly deform.
3. A blister pack according to claim 1 or claim 2 wherein the material is reinforced by the combination of the blister pack with a rigid support.
- 10 4. A blister pack according to claim 3 comprising a combination of a blister pack and a substantially rigid reinforcing support for the blister pack, the support comprising a substantially planar slab of substantially rigid material having a pattern of holes passing completely through the thickness of the slab, the said holes being in a pattern corresponding to the blisters of the blister pack, the blister pack being in
15 contact with the support such that each blister fits into a hole, each blister being accessible to a user via the hole.
5. A blister pack according to claim 3 comprising a combination of a blister pack and a substantially rigid support for the blister pack, the support comprising a substantially planar slab of substantially rigid material having a pattern of holes in
20 its surface, which pass only partly through the thickness of the slab, the said holes being in a pattern corresponding to the blisters on the blister pack, the blister pack being in contact with the holder such that each blister fits into a hole, the blister pack having a peel-off film cover over the open face of the blister.
6. A blister pack according to claim 3 comprising a combination of a blister
25 pack and a substantially rigid but support for the blister pack, the support comprising a substantially planar slab of substantially rigid material having a pattern of holes in its surface, which pass only partly through the thickness of the slab, the said holes being in a pattern corresponding to the blisters on the blister pack, the blister pack being in contact with the holder such that each blister fits into a hole,
30 the blister pack having a rupturable film cover over the open face of the blister, the material of the slab being compressibly deformable at least in the region of the

holes, such that pressure can be applied to the slab on the reverse face to that on which the holes open, so as to thereby deform the said material and apply pressure to the blister, and so to force the tablet out through the rupturable film cover.

7. A blister pack according to claim 3 comprising a combination of a blister
5 pack and a substantially rigid reinforcing support for the blister pack, the support comprising a substantially planar slab of substantially rigid material having a pattern of holes passing completely through the thickness of the slab, the said holes being in a pattern corresponding to the blisters of the blister pack, the blister pack being in contact with the support such that each blister fits over a hole, each blister having a
10 rupturable film cover over its open face, the film cover facing the upper surface of the slab, the slab having a thickness such that the blister may be compressibly deformed when the pack is laid upon a surface so as to force the tablet out through the film and through the hole.

8. A blister pack according to claim 1 or 2 wherein the deformeable material
15 between blisters is rendered rigid by the formation therein of structural strengthening ribs.

9. A blister pack according to claim 1 or 2 wherein the material between the blisters is reinforced by a general thickening of the material to impart rigidity.

Fig.1.

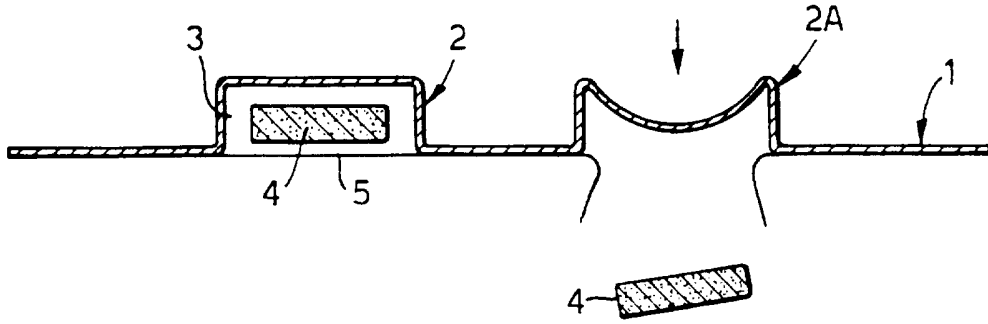

Fig.2.

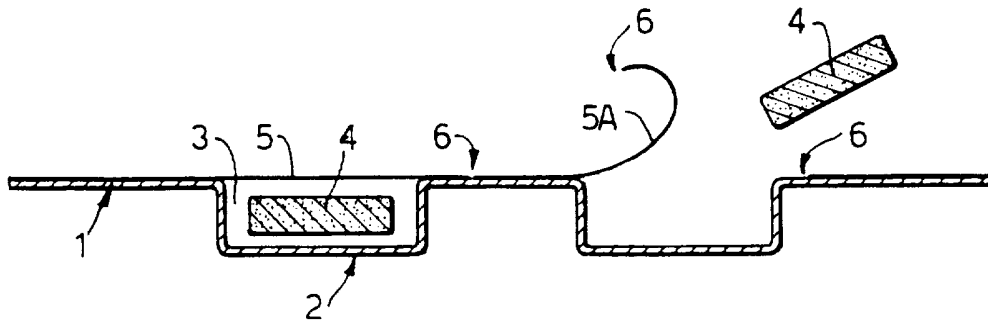

Fig.3.

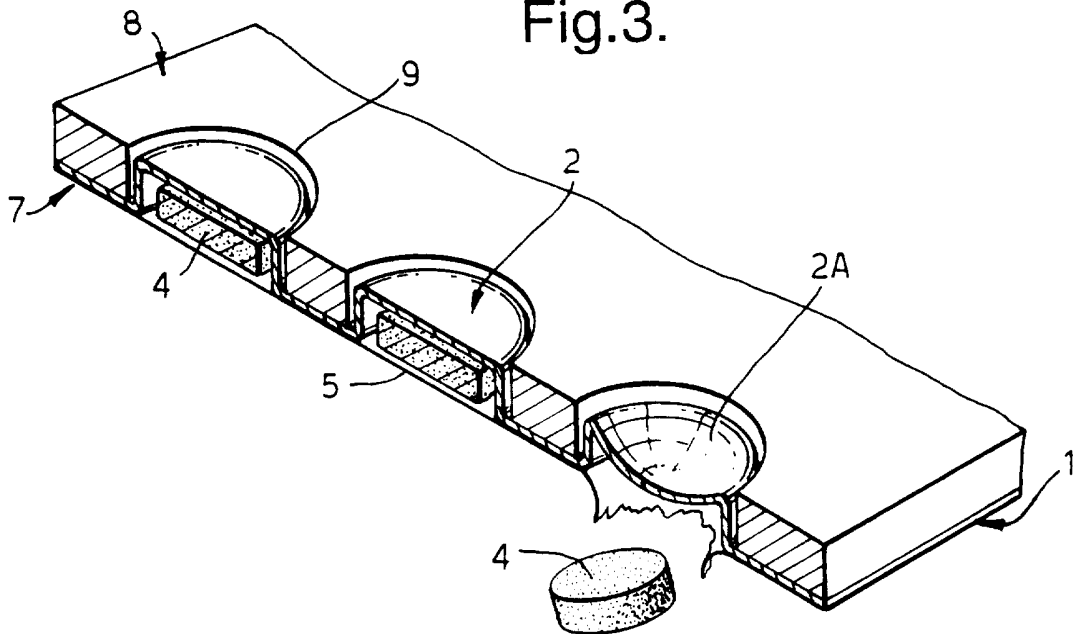

Fig.4.

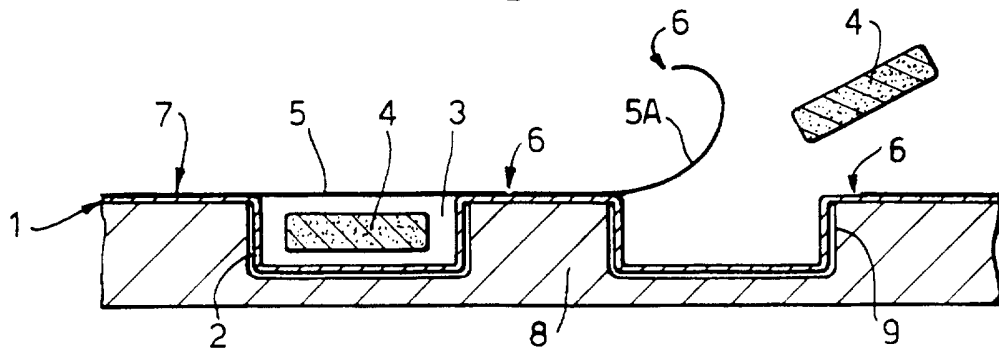

Fig.5.

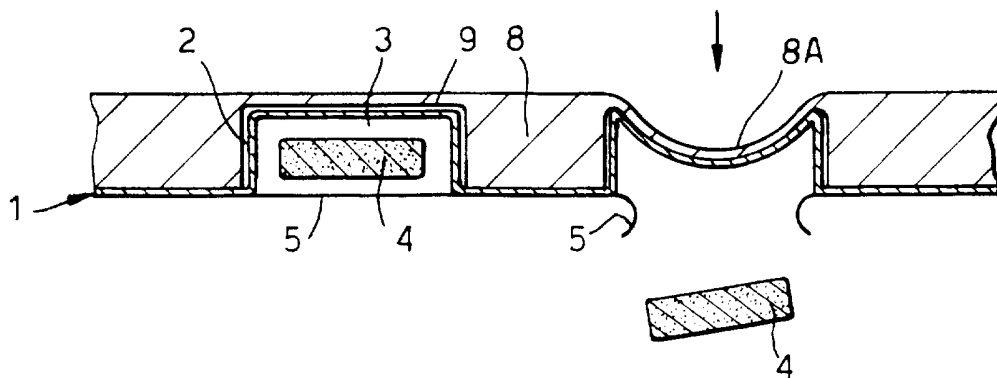

Fig.6.

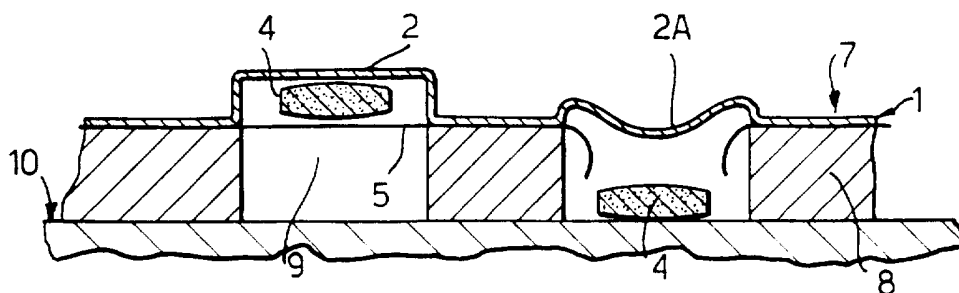

Fig.7A.

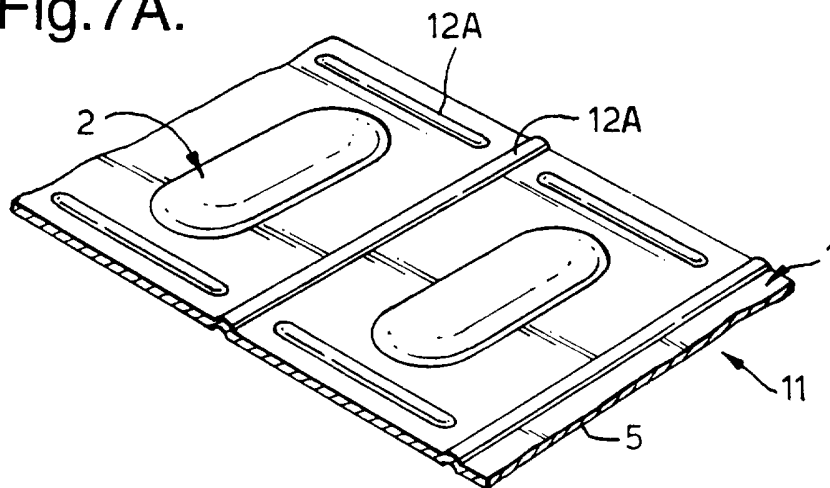

Fig.7B.

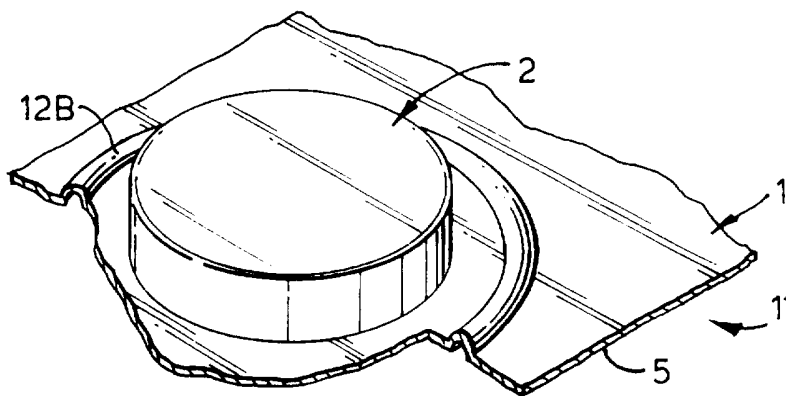
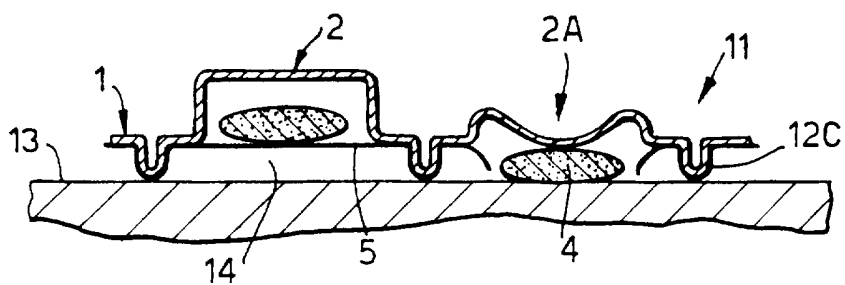

Fig.7C.



INTERNATIONAL SEARCH REPORT

International Application No

PCT/EP 96/05536

A. CLASSIFICATION OF SUBJECT MATTER
IPC 6 B65D75/34

According to International Patent Classification (IPC) or to both national classification and IPC

B. FIELDS SEARCHED

Minimum documentation searched (classification system followed by classification symbols)
IPC 6 B65D A61J

Documentation searched other than minimum documentation to the extent that such documents are included in the fields searched

Electronic data base consulted during the international search (name of data base and, where practical, search terms used)

C. DOCUMENTS CONSIDERED TO BE RELEVANT

Category *	Citation of document, with indication, where appropriate, of the relevant passages	Relevant to claim No.
X A	US 4 958 736 A (URHEIM) 25 September 1990 see column 2, line 53-66; figures 1,2 ---	1-3,7,9 4
X	US 4 125 190 A (DAVIE) 14 November 1978 see column 4, line 8 - column 7, line 18; figures 1-8 ---	1-4,7,9
A	BE 1 003 274 A (ELST) 11 February 1992 see page 5, line 8 - line 20; figures 4-7 ---	5,6
A	EP 0 146 063 A (HOECHST) 26 June 1985 see page 4, column 1-7; figures 1,2 ---	8
A	FR 1 560 988 A (THE DOW CHEMICAL COMP.) 21 March 1969 see page 4, line 35 - page 5, line 8; figures 1-7 ---	8
	-/--	

Further documents are listed in the continuation of box C.

Patent family members are listed in annex.

* Special categories of cited documents :

- *A* document defining the general state of the art which is not considered to be of particular relevance
- *E* earlier document but published on or after the international filing date
- *L* document which may throw doubts on priority claim(s) or which is cited to establish the publication date of another citation or other special reason (as specified)
- *O* document referring to an oral disclosure, use, exhibition or other means
- *P* document published prior to the international filing date but later than the priority date claimed

- *T* later document published after the international filing date or priority date and not in conflict with the application but cited to understand the principle or theory underlying the invention
- *X* document of particular relevance; the claimed invention cannot be considered novel or cannot be considered to involve an inventive step when the document is taken alone
- *Y* document of particular relevance; the claimed invention cannot be considered to involve an inventive step when the document is combined with one or more other such documents, such combination being obvious to a person skilled in the art.
- *&* document member of the same patent family

Date of the actual completion of the international search

11 April 1997

Date of mailing of the international search report

17.04.97

Name and mailing address of the ISA

European Patent Office, P.B. 5818 Patentlaan 2
NL - 2280 HV Rijswijk
Tel. (+ 31-70) 340-2040, Tx. 31 651 epo nl,
Fax (+ 31-70) 340-3016

Authorized officer

Vollering, J

INTERNATIONAL SEARCH REPORT

International Application No

PCT/EP 96/05536

C.(Continuation) DOCUMENTS CONSIDERED TO BE RELEVANT

Category *	Citation of document, with indication, where appropriate, of the relevant passages	Relevant to claim No.
A	EP 0 598 922 A (SANKYO COMP. LTD.) 1 June 1994 see page 5, line 20 - line 39; figure 4 -----	9

INTERNATIONAL SEARCH REPORT

Information on patent family members

International Application No

PCT/EP 96/05536

Patent document cited in search report	Publication date	Patent family member(s)	Publication date
US 4958736 A	25-09-90	NONE	
US 4125190 A	14-11-78	NONE	
BE 1003274 A	11-02-92	NONE	
EP 146063 A	26-06-85	DE 3344393 A	20-06-85
		AU 575099 B	21-07-88
		AU 3642484 A	13-06-85
		CA 1246501 A	13-12-88
		JP 60158058 A	19-08-85
FR 1560988 A	21-03-69	BE 715224 A	18-11-68
		DE 1761410 A	01-07-71
		GB 1230178 A	28-04-71
		NL 6806744 A	18-11-68
		SE 359788 B	10-09-73
		US 3454158 A	08-07-69
EP 598922 A	01-06-94	US 5495705 A	05-03-96
		WO 9325451 A	23-12-93