



(51) International Patent Classification:  
H04N 19/103 (2014.01)

(21) International Application Number:  
PCT/US2022/076408

(22) International Filing Date:  
14 September 2022 (14.09.2022)

(25) Filing Language: English

(26) Publication Language: English

(30) Priority Data:  
63/252,600 05 October 2021 (05.10.2021) US  
17/943,275 13 September 2022 (13.09.2022) US

(71) Applicant: TENCENT AMERICA LLC [US/US]; 2747 Park Boulevard, Palo Alto, California 94306 (US).

(72) Inventors: LI, Ling; c/o Tencent America LLC, 2747 Park Boulevard, Palo Alto, California 94306 (US). LI, Xiang;

c/o Tencent America LLC, 2747 Park Boulevard, Palo Alto, California 94306 (US). LIU, Shan; c/o Tencent America LLC, 2747 Park Boulevard, Palo Alto, California 94306 (US).

(74) Agent: MA, Johnny; ArentFox Schiff LLP, 1717 K Street NW, Washington, District of Columbia 20006 (US).

(81) Designated States (unless otherwise indicated, for every kind of national protection available): AE, AG, AL, AM, AO, AT, AU, AZ, BA, BB, BG, BH, BN, BR, BW, BY, BZ, CA, CH, CL, CN, CO, CR, CU, CV, CZ, DE, DJ, DK, DM, DO, DZ, EC, EE, EG, ES, FI, GB, GD, GE, GH, GM, GT, HN, HR, HU, ID, IL, IN, IQ, IR, IS, IT, JM, JO, JP, KE, KG, KH, KN, KP, KR, KW, KZ, LA, LC, LK, LR, LS, LU, LY, MA, MD, ME, MG, MK, MN, MW, MX, MY, MZ, NA, NG, NI, NO, NZ, OM, PA, PE, PG, PH, PL, PT, QA, RO, RS, RU, RW, SA, SC, SD, SE, SG, SK, SL, ST, SV, SY, TH,

(54) Title: MODIFICATION ON FUSION OF INTRA PREDICTION

	R01	R02	R03	R04	R05	R06	R07	R08	R09
R10	S11	S12	S13	S14					
R20	S21	S22	S23	S24					
R30	S31	S32	S33	S34					
R40	S41	S42	S43	S44					
R50									
R60									
R70									

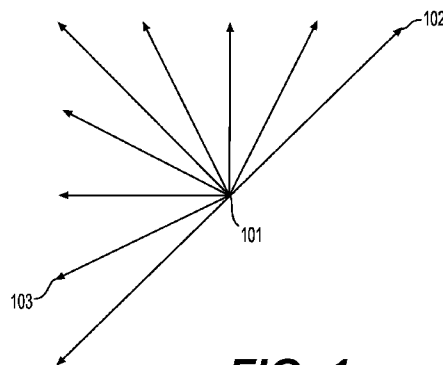
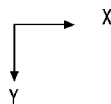

FIG. 1

(57) Abstract: One or more intra mode predictors of a current block are determined, where the one or more intra mode predictors are derived based on the neighboring samples of the current block via either a decoder side intra mode derivation (DIMD) or a template-based intra mode derivation (TIMD). Whether a position dependent intra prediction combination (PDPC) is to be applied is determined based on the one or more intra mode predictors. In response to the determining that the PDPC is to be applied, a fusion process is performed on the one or more intra mode predictors to combine the one or more intra mode predictors into a single intra mode predictor. The PDPC is applied based on the single intra mode predictor to generate a modified predictor of the current block. The current block is reconstructed based on the modified predictor generated by the PDPC.



TJ, TM, TN, TR, TT, TZ, UA, UG, US, UZ, VC, VN, WS,  
ZA, ZM, ZW.

**(84) Designated States** (*unless otherwise indicated, for every kind of regional protection available*): ARIPO (BW, GH, GM, KE, LR, LS, MW, MZ, NA, RW, SD, SL, ST, SZ, TZ, UG, ZM, ZW), Eurasian (AM, AZ, BY, KG, KZ, RU, TJ, TM), European (AL, AT, BE, BG, CH, CY, CZ, DE, DK, EE, ES, FI, FR, GB, GR, HR, HU, IE, IS, IT, LT, LU, LV, MC, MK, MT, NL, NO, PL, PT, RO, RS, SE, SI, SK, SM, TR), OAPI (BF, BJ, CF, CG, CI, CM, GA, GN, GQ, GW, KM, ML, MR, NE, SN, TD, TG).

**Published:**

— *with international search report (Art. 21(3))*

## MODIFICATION ON FUSION OF INTRA PREDICTION

### INCORPORATION BY REFERENCE

**[0001]** The present application claims the benefit of priority to U.S. Patent Application No. 17/943,275, “MODIFICATION ON FUSION OF INTRA PREDICTION” filed on September 13, 2022, which claims the benefit of priority to U.S. Provisional Application No. 63/252,600, “Modification on Fusion of Intra Prediction” filed on October 5, 2021. The disclosures of the prior applications are hereby incorporated by reference in their entirety.

### TECHNICAL FIELD

**[0002]** The present disclosure describes embodiments generally related to video coding.

### BACKGROUND

**[0003]** The background description provided herein is for the purpose of generally presenting the context of the disclosure. Work of the presently named inventors, to the extent the work is described in this background section, as well as aspects of the description that may not otherwise qualify as prior art at the time of filing, are neither expressly nor impliedly admitted as prior art against the present disclosure.

**[0004]** Video coding and decoding can be performed using inter-picture prediction with motion compensation. Uncompressed digital video can include a series of pictures, each picture having a spatial dimension of, for example, 1920 x 1080 luminance samples and associated chrominance samples. The series of pictures can have a fixed or variable picture rate (informally also known as frame rate), of, for example 60 pictures per second or 60 Hz. Uncompressed video has specific bitrate requirements. For example, 1080p60 4:2:0 video at 8 bit per sample (1920x1080 luminance sample resolution at 60 Hz frame rate) requires close to 1.5 Gbit/s bandwidth. An hour of such video requires more than 600 GBytes of storage space.

**[0005]** One purpose of video coding and decoding can be the reduction of redundancy in the input video signal, through compression. Compression can help reduce the aforementioned bandwidth and/or storage space requirements, in some cases by two orders of magnitude or more. Both lossless compression and lossy compression, as well as a combination thereof can be

employed. Lossless compression refers to techniques where an exact copy of the original signal can be reconstructed from the compressed original signal. When using lossy compression, the reconstructed signal may not be identical to the original signal, but the distortion between original and reconstructed signals is small enough to make the reconstructed signal useful for the intended application. In the case of video, lossy compression is widely employed. The amount of distortion tolerated depends on the application; for example, users of certain consumer streaming applications may tolerate higher distortion than users of television distribution applications. The compression ratio achievable can reflect that: higher allowable/tolerable distortion can yield higher compression ratios.

**[0006]** A video encoder and decoder can utilize techniques from several broad categories, including, for example, motion compensation, transform, quantization, and entropy coding.

**[0007]** Video codec technologies can include techniques known as intra coding. In intra coding, sample values are represented without reference to samples or other data from previously reconstructed reference pictures. In some video codecs, the picture is spatially subdivided into blocks of samples. When all blocks of samples are coded in intra mode, that picture can be an intra picture. Intra pictures and their derivations such as independent decoder refresh pictures, can be used to reset the decoder state and can, therefore, be used as the first picture in a coded video bitstream and a video session, or as a still image. The samples of an intra block can be exposed to a transform, and the transform coefficients can be quantized before entropy coding. Intra prediction can be a technique that minimizes sample values in the pre-transform domain. In some cases, the smaller the DC value after a transform is, and the smaller the AC coefficients are, the fewer the bits that are required at a given quantization step size to represent the block after entropy coding.

**[0008]** Traditional intra coding such as known from, for example MPEG-2 generation coding technologies, does not use intra prediction. However, some newer video compression technologies include techniques that attempt, from, for example, surrounding sample data and/or metadata obtained during the encoding and/or decoding of spatially neighboring, and preceding in decoding order, blocks of data. Such techniques are henceforth called “intra prediction” techniques. Note that in at least some cases, intra prediction is using reference data only from the current picture under reconstruction and not from reference pictures.

**[0009]** There can be many different forms of intra prediction. When more than one of such techniques can be used in a given video coding technology, the technique in use can be coded in an intra prediction mode. In certain cases, modes can have submodes and/or parameters, and those can be coded individually or included in the mode codeword. Which codeword to use for a given mode, submode, and/or parameter combination can have an impact in the coding efficiency gain through intra prediction, and so can the entropy coding technology used to translate the codewords into a bitstream.

**[0010]** A certain mode of intra prediction was introduced with H.264, refined in H.265, and further refined in newer coding technologies such as joint exploration model (JEM), versatile video coding (VVC), and benchmark set (BMS). A predictor block can be formed using neighboring sample values belonging to already available samples. Sample values of neighboring samples are copied into the predictor block according to a direction. A reference to the direction in use can be coded in the bitstream or may itself be predicted.

**[0011]** Referring to FIG. 1, depicted in the lower right is a subset of nine predictor directions known from H.265's 33 possible predictor directions (corresponding to the 33 angular modes of the 35 intra modes). The point where the arrows converge (101) represents the sample being predicted. The arrows represent the direction from which the sample is being predicted. For example, arrow (102) indicates that sample (101) is predicted from a sample or samples to the upper right, at a 45 degree angle from the horizontal. Similarly, arrow (103) indicates that sample (101) is predicted from a sample or samples to the lower left of sample (101), in a 22.5 degree angle from the horizontal.

**[0012]** Still referring to FIG. 1, on the top left there is depicted a square block (104) of 4 x 4 samples (indicated by a dashed, boldface line). The square block (104) includes 16 samples, each labelled with an "S", its position in the Y dimension (e.g., row index) and its position in the X dimension (e.g., column index). For example, sample S21 is the second sample in the Y dimension (from the top) and the first (from the left) sample in the X dimension. Similarly, sample S44 is the fourth sample in block (104) in both the Y and X dimensions. As the block is 4 x 4 samples in size, S44 is at the bottom right. Further shown are reference samples that follow a similar numbering scheme. A reference sample is labelled with an R, its Y position (e.g., row index) and X position (column index) relative to block (104). In both H.264 and

H.265, prediction samples neighbor the block under reconstruction; therefore no negative values need to be used.

**[0013]** Intra picture prediction can work by copying reference sample values from the neighboring samples as appropriated by the signaled prediction direction. For example, assume the coded video bitstream includes signaling that, for this block, indicates a prediction direction consistent with arrow (102)—that is, samples are predicted from a prediction sample or samples to the upper right, at a 45 degree angle from the horizontal. In that case, samples S41, S32, S23, and S14 are predicted from the same reference sample R05. Sample S44 is then predicted from reference sample R08.

**[0014]** In certain cases, the values of multiple reference samples may be combined, for example through interpolation, in order to calculate a reference sample; especially when the directions are not evenly divisible by 45 degrees.

**[0015]** The number of possible directions has increased as video coding technology has developed. In H.264 (year 2003), nine different direction could be represented. That increased to 33 in H.265 (year 2013), and JEM/VVC/BMS, at the time of disclosure, can support up to 65 directions. Experiments have been conducted to identify the most likely directions, and certain techniques in the entropy coding are used to represent those likely directions in a small number of bits, accepting a certain penalty for less likely directions. Further, the directions themselves can sometimes be predicted from neighboring directions used in neighboring, already decoded, blocks.

**[0016]** FIG. 2 shows a schematic (201) that depicts 65 intra prediction directions according to JEM to illustrate the increasing number of prediction directions over time.

**[0017]** The mapping of intra prediction directions bits in the coded video bitstream that represent the direction can be different from video coding technology to video coding technology; and can range, for example, from simple direct mappings of prediction direction to intra prediction mode, to codewords, to complex adaptive schemes involving most probable modes, and similar techniques. In all cases, however, there can be certain directions that are statistically less likely to occur in video content than certain other directions. As the goal of video compression is the reduction of redundancy, those less likely directions will, in a well working video coding technology, be represented by a larger number of bits than more likely directions.

### SUMMARY

**[0018]** Aspects of the disclosure provide methods and apparatuses for video encoding/decoding. In some examples, an apparatus for video decoding includes receiving circuitry and processing circuitry.

**[0019]** According to an aspect of the disclosure, a method of video decoding performed in a video decoder is provided. In the method, coded information of a current block and neighboring samples of the current block can be received from a coded video bitstream. One or more intra mode predictors of the current block can be determined, where the one or more intra mode predictors can be derived based on the neighboring samples of the current block via either a decoder side intra mode derivation (DIMD) or a template-based intra mode derivation (TIMD). Whether a position dependent intra prediction combination (PDPC) is to be applied can be determined based on the one or more intra mode predictors. In response to the determining that the PDPC is to be applied, a fusion process can be performed on the one or more intra mode predictors, where the fusion process can combine the one or more intra mode predictors to generate a single intra mode predictor. The PDPC can be applied based on the single intra mode predictor to generate a modified predictor of the current block subsequent to the fusion process on the one or more intra mode predictors. The current block can be reconstructed based on the modified predictor generated by the PDPC.

**[0020]** In some embodiments, the fusion process can include generating the single intra mode predictor based on a weighted combination of the one or more intra mode predictors. In some embodiments, the PDPC further can include generating the modified predictor based on a weighted combination of (i) one or more neighboring samples of the neighboring samples and (ii) the single intra mode predictor.

**[0021]** In response to the one or more intra mode predictors being derived based on the DIMD, a first intra mode predictor of the one or more intra mode predictors can be determined based on a first intra mode. The first intra mode can be determined based on the neighboring samples and associated with a highest histogram of gradient (HoG) of the neighboring samples. A second intra mode predictor of the one or more intra mode predictors can be determined based on a second intra mode. The second intra mode can be determined based on the neighboring samples and associated with a second highest HoG of the neighboring samples. A third intra

mode predictor of the one or more intra mode predictors can be determined based on a planar mode.

**[0022]** In some embodiments, whether the PDPC is applicable can be determined based on the first intra mode that is derived based on the DIMD.

**[0023]** In response to the first intra mode and the second intra mode being angular modes, whether the PDPC is applicable can be determined based on an average angular value of the first intra mode and the second intra mode. In response to one of the first intra mode and the second intra mode being an angular mode, whether the PDPC is applicable can be determined based on the one of the first intra mode and the second intra mode that is the angular mode.

**[0024]** In some embodiments, the PDPC can be determined to be applicable in response to at least one of the one or more intra mode predictors being generated based on a planar mode or a DC mode.

**[0025]** In response to the one or more intra mode predictors being derived based on the TIMD, a first intra mode predictor of the one or more intra mode predictors can be determined based on a first intra mode, where the first intra mode can be determined based on the neighboring samples and associated with a smallest cost value of the neighboring samples. A second intra mode predictor of the one or more intra mode predictors can be determined based on a second intra mode, where the second intra mode can be determined based on the neighboring samples and associated with a second smallest cost value of the neighboring samples.

**[0026]** In some embodiments, whether the PDPC is applicable can be determined based on the first intra mode that is derived based on the TIMD.

**[0027]** In response to the first intra mode and the second intra mode being angular modes, whether the PDPC is applicable can be determined based on an average angular value of the first intra mode and the second intra mode. In response to one of the first intra mode and the second intra mode being an angular mode, whether the PDPC is applicable can be determined based on the one of the first intra mode and the second intra mode that is the angular mode.

**[0028]** In some embodiments, the PDPC can be determined to be applicable in response to at least one of the first intra mode and the second intra mode being a planar mode or a DC mode.

**[0029]** According to another aspect of the disclosure, an apparatus is provided. The apparatus has processing circuitry. The processing circuitry can be configured to perform any of the methods for video coding.

**[0030]** Aspects of the disclosure also provide a non-transitory computer-readable medium storing instructions which when executed by a computer for video decoding cause the computer to perform any of the methods for video decoding.

### BRIEF DESCRIPTION OF THE DRAWINGS

**[0031]** Further features, the nature, and various advantages of the disclosed subject matter will be more apparent from the following detailed description and the accompanying drawings in which:

**[0032]** FIG. 1 is a schematic illustration of an exemplary subset of intra prediction modes.

**[0033]** FIG. 2 is an illustration of exemplary intra prediction directions.

**[0034]** FIG. 3 is a schematic illustration of a simplified block diagram of a communication system (300) in accordance with an embodiment.

**[0035]** FIG. 4 is a schematic illustration of a simplified block diagram of a communication system (400) in accordance with an embodiment.

**[0036]** FIG. 5 is a schematic illustration of a simplified block diagram of a decoder in accordance with an embodiment.

**[0037]** FIG. 6 is a schematic illustration of a simplified block diagram of an encoder in accordance with an embodiment.

**[0038]** FIG. 7 shows a block diagram of an encoder in accordance with another embodiment.

**[0039]** FIG. 8 shows a block diagram of a decoder in accordance with another embodiment.

**[0040]** FIG. 9A is a first exemplary illustration of a position dependent intra prediction combination (PDPC) mode according to some embodiments of the disclosure.

**[0041]** FIG. 9B is a second exemplary illustration of the PDPC mode according to some embodiments of the disclosure.

**[0042]** FIG. 9C is a third exemplary illustration of the PDPC mode according to some embodiments of the disclosure.

**[0043]** FIG. 9D is a fourth exemplary illustration of the PDPC mode according to some embodiments of the disclosure.

**[0044]** FIG. 10 is a schematic illustration of decoder side intra mode derivation (DIMD) with fusion according to some embodiments of the disclosure.

**[0045]** FIG. 11 is a schematic illustration of template-based intra mode derivation (TIMD) according to some embodiments of the disclosure.

**[0046]** FIG. 12 is a schematic illustration of TIMD with fusion according to some embodiments of the disclosure.

**[0047]** FIG. 13 is a schematic illustration of DIMD with fusion according to some embodiments of the disclosure.

**[0048]** FIG. 14 is a schematic illustration of TIMD with fusion according to some embodiments of the disclosure.

**[0049]** FIG. 15A is an exemplary process of DIMD according to some embodiments of the disclosure.

**[0050]** FIG. 15B is an exemplary process of TIMD according to some embodiments of the disclosure.

**[0051]** FIG. 16 shows a flow chart outlining an exemplary decoding process according to some embodiments of the disclosure.

**[0052]** FIG. 17 shows a flow chart outlining an exemplary encoding process according to some embodiments of the disclosure.

**[0053]** FIG. 18 is a schematic illustration of a computer system in accordance with an embodiment.

#### DETAILED DESCRIPTION OF EMBODIMENTS

**[0054]** FIG. 3 illustrates a simplified block diagram of a communication system (300) according to an embodiment of the present disclosure. The communication system (300) includes a plurality of terminal devices that can communicate with each other, via, for example, a network (350). For example, the communication system (300) includes a first pair of terminal devices (310) and (320) interconnected via the network (350). In the FIG. 3 example, the first

pair of terminal devices (310) and (320) performs unidirectional transmission of data. For example, the terminal device (310) may code video data (e.g., a stream of video pictures that are captured by the terminal device (310)) for transmission to the other terminal device (320) via the network (350). The encoded video data can be transmitted in the form of one or more coded video bitstreams. The terminal device (320) may receive the coded video data from the network (350), decode the coded video data to recover the video pictures and display video pictures according to the recovered video data. Unidirectional data transmission may be common in media serving applications and the like.

**[0055]** In another example, the communication system (300) includes a second pair of terminal devices (330) and (340) that performs bidirectional transmission of coded video data that may occur, for example, during videoconferencing. For bidirectional transmission of data, in an example, each terminal device of the terminal devices (330) and (340) may code video data (e.g., a stream of video pictures that are captured by the terminal device) for transmission to the other terminal device of the terminal devices (330) and (340) via the network (350). Each terminal device of the terminal devices (330) and (340) also may receive the coded video data transmitted by the other terminal device of the terminal devices (330) and (340), and may decode the coded video data to recover the video pictures and may display video pictures at an accessible display device according to the recovered video data.

**[0056]** In the FIG. 3 example, the terminal devices (310), (320), (330) and (340) may be illustrated as servers, personal computers and smart phones but the principles of the present disclosure may be not so limited. Embodiments of the present disclosure find application with laptop computers, tablet computers, media players and/or dedicated video conferencing equipment. The network (350) represents any number of networks that convey coded video data among the terminal devices (310), (320), (330) and (340), including for example wireline (wired) and/or wireless communication networks. The communication network (350) may exchange data in circuit-switched and/or packet-switched channels. Representative networks include telecommunications networks, local area networks, wide area networks and/or the Internet. For the purposes of the present discussion, the architecture and topology of the network (350) may be immaterial to the operation of the present disclosure unless explained herein below.

**[0057]** FIG. 4 illustrates, as an example for an application for the disclosed subject matter, the placement of a video encoder and a video decoder in a streaming environment. The

disclosed subject matter can be equally applicable to other video enabled applications, including, for example, video conferencing, digital TV, storing of compressed video on digital media including CD, DVD, memory stick and the like, and so on.

**[0058]** A streaming system may include a capture subsystem (413), that can include a video source (401), for example a digital camera, creating for example a stream of video pictures (402) that are uncompressed. In an example, the stream of video pictures (402) includes samples that are taken by the digital camera. The stream of video pictures (402), depicted as a bold line to emphasize a high data volume when compared to encoded video data (404) (or coded video bitstreams), can be processed by an electronic device (420) that includes a video encoder (403) coupled to the video source (401). The video encoder (403) can include hardware, software, or a combination thereof to enable or implement aspects of the disclosed subject matter as described in more detail below. The encoded video data (404) (or encoded video bitstream (404)), depicted as a thin line to emphasize the lower data volume when compared to the stream of video pictures (402), can be stored on a streaming server (405) for future use. One or more streaming client subsystems, such as client subsystems (406) and (408) in FIG. 4 can access the streaming server (405) to retrieve copies (407) and (409) of the encoded video data (404). A client subsystem (406) can include a video decoder (410), for example, in an electronic device (430). The video decoder (410) decodes the incoming copy (407) of the encoded video data and creates an outgoing stream of video pictures (411) that can be rendered on a display (412) (e.g., display screen) or other rendering device (not depicted). In some streaming systems, the encoded video data (404), (407), and (409) (e.g., video bitstreams) can be encoded according to certain video coding/compression standards. Examples of those standards include ITU-T Recommendation H.265. In an example, a video coding standard under development is informally known as Versatile Video Coding (VVC). The disclosed subject matter may be used in the context of VVC.

**[0059]** It is noted that the electronic devices (420) and (430) can include other components (not shown). For example, the electronic device (420) can include a video decoder (not shown) and the electronic device (430) can include a video encoder (not shown) as well.

**[0060]** FIG. 5 shows a block diagram of a video decoder (510) according to an embodiment of the present disclosure. The video decoder (510) can be included in an electronic device (530). The electronic device (530) can include a receiver (531) (e.g., receiving circuitry).

The video decoder (510) can be used in the place of the video decoder (410) in the FIG. 4 example.

**[0061]** The receiver (531) may receive one or more coded video sequences to be decoded by the video decoder (510); in the same or another embodiment, one coded video sequence at a time, where the decoding of each coded video sequence is independent from other coded video sequences. The coded video sequence may be received from a channel (501), which may be a hardware/software link to a storage device which stores the encoded video data. The receiver (531) may receive the encoded video data with other data, for example, coded audio data and/or ancillary data streams, that may be forwarded to their respective using entities (not depicted). The receiver (531) may separate the coded video sequence from the other data. To combat network jitter, a buffer memory (515) may be coupled in between the receiver (531) and an entropy decoder / parser (520) ("parser (520)" henceforth). In certain applications, the buffer memory (515) is part of the video decoder (510). In others, it can be outside of the video decoder (510) (not depicted). In still others, there can be a buffer memory (not depicted) outside of the video decoder (510), for example to combat network jitter, and in addition another buffer memory (515) inside the video decoder (510), for example to handle playout timing. When the receiver (531) is receiving data from a store/forward device of sufficient bandwidth and controllability, or from an isosynchronous network, the buffer memory (515) may not be needed, or can be small. For use on best effort packet networks such as the Internet, the buffer memory (515) may be required, can be comparatively large and can be advantageously of adaptive size, and may at least partially be implemented in an operating system or similar elements (not depicted) outside of the video decoder (510).

**[0062]** The video decoder (510) may include the parser (520) to reconstruct symbols (521) from the coded video sequence. Categories of those symbols include information used to manage operation of the video decoder (510), and potentially information to control a rendering device such as a render device (512) (e.g., a display screen) that is not an integral part of the electronic device (530) but can be coupled to the electronic device (530), as was shown in FIG. 5. The control information for the rendering device(s) may be in the form of Supplemental Enhancement Information (SEI messages) or Video Usability Information (VUI) parameter set fragments (not depicted). The parser (520) may parse / entropy-decode the coded video sequence that is received. The coding of the coded video sequence can be in accordance with a

video coding technology or standard, and can follow various principles, including variable length coding, Huffman coding, arithmetic coding with or without context sensitivity, and so forth. The parser (520) may extract from the coded video sequence, a set of subgroup parameters for at least one of the subgroups of pixels in the video decoder, based upon at least one parameter corresponding to the group. Subgroups can include Groups of Pictures (GOPs), pictures, tiles, slices, macroblocks, Coding Units (CUs), blocks, Transform Units (TUs), Prediction Units (PUs) and so forth. The parser (520) may also extract from the coded video sequence information such as transform coefficients, quantizer parameter values, motion vectors, and so forth.

**[0063]** The parser (520) may perform an entropy decoding / parsing operation on the video sequence received from the buffer memory (515), so as to create symbols (521).

**[0064]** Reconstruction of the symbols (521) can involve multiple different units depending on the type of the coded video picture or parts thereof (such as: inter and intra picture, inter and intra block), and other factors. Which units are involved, and how, can be controlled by the subgroup control information that was parsed from the coded video sequence by the parser (520). The flow of such subgroup control information between the parser (520) and the multiple units below is not depicted for clarity.

**[0065]** Beyond the functional blocks already mentioned, the video decoder (510) can be conceptually subdivided into a number of functional units as described below. In a practical implementation operating under commercial constraints, many of these units interact closely with each other and can, at least partly, be integrated into each other. However, for the purpose of describing the disclosed subject matter, the conceptual subdivision into the functional units below is appropriate.

**[0066]** A first unit is the scaler / inverse transform unit (551). The scaler / inverse transform unit (551) receives a quantized transform coefficient as well as control information, including which transform to use, block size, quantization factor, quantization scaling matrices, etc. as symbol(s) (521) from the parser (520). The scaler / inverse transform unit (551) can output blocks comprising sample values, that can be input into aggregator (555).

**[0067]** In some cases, the output samples of the scaler / inverse transform (551) can pertain to an intra coded block; that is: a block that is not using predictive information from previously reconstructed pictures, but can use predictive information from previously reconstructed parts of the current picture. Such predictive information can be provided by an

intra picture prediction unit (552). In some cases, the intra picture prediction unit (552) generates a block of the same size and shape of the block under reconstruction, using surrounding already reconstructed information fetched from the current picture buffer (558). The current picture buffer (558) buffers, for example, partly reconstructed current picture and/or fully reconstructed current picture. The aggregator (555), in some cases, adds, on a per sample basis, the prediction information the intra prediction unit (552) has generated to the output sample information as provided by the scaler / inverse transform unit (551).

**[0068]** In other cases, the output samples of the scaler / inverse transform unit (551) can pertain to an inter coded, and potentially motion compensated block. In such a case, a motion compensation prediction unit (553) can access reference picture memory (557) to fetch samples used for prediction. After motion compensating the fetched samples in accordance with the symbols (521) pertaining to the block, these samples can be added by the aggregator (555) to the output of the scaler / inverse transform unit (551) (in this case called the residual samples or residual signal) so as to generate output sample information. The addresses within the reference picture memory (557) from where the motion compensation prediction unit (553) fetches prediction samples can be controlled by motion vectors, available to the motion compensation prediction unit (553) in the form of symbols (521) that can have, for example X, Y, and reference picture components. Motion compensation also can include interpolation of sample values as fetched from the reference picture memory (557) when sub-sample exact motion vectors are in use, motion vector prediction mechanisms, and so forth.

**[0069]** The output samples of the aggregator (555) can be subject to various loop filtering techniques in the loop filter unit (556). Video compression technologies can include in-loop filter technologies that are controlled by parameters included in the coded video sequence (also referred to as coded video bitstream) and made available to the loop filter unit (556) as symbols (521) from the parser (520), but can also be responsive to meta-information obtained during the decoding of previous (in decoding order) parts of the coded picture or coded video sequence, as well as responsive to previously reconstructed and loop-filtered sample values.

**[0070]** The output of the loop filter unit (556) can be a sample stream that can be output to the render device (512) as well as stored in the reference picture memory (557) for use in future inter-picture prediction.

**[0071]** Certain coded pictures, once fully reconstructed, can be used as reference pictures for future prediction. For example, once a coded picture corresponding to a current picture is fully reconstructed and the coded picture has been identified as a reference picture (by, for example, the parser (520)), the current picture buffer (558) can become a part of the reference picture memory (557), and a fresh current picture buffer can be reallocated before commencing the reconstruction of the following coded picture.

**[0072]** The video decoder (510) may perform decoding operations according to a predetermined video compression technology in a standard, such as ITU-T Rec. H.265. The coded video sequence may conform to a syntax specified by the video compression technology or standard being used, in the sense that the coded video sequence adheres to both the syntax of the video compression technology or standard and the profiles as documented in the video compression technology or standard. Specifically, a profile can select certain tools as the only tools available for use under that profile from all the tools available in the video compression technology or standard. Also necessary for compliance can be that the complexity of the coded video sequence is within bounds as defined by the level of the video compression technology or standard. In some cases, levels restrict the maximum picture size, maximum frame rate, maximum reconstruction sample rate (measured in, for example megasamples per second), maximum reference picture size, and so on. Limits set by levels can, in some cases, be further restricted through Hypothetical Reference Decoder (HRD) specifications and metadata for HRD buffer management signaled in the coded video sequence.

**[0073]** In an embodiment, the receiver (531) may receive additional (redundant) data with the encoded video. The additional data may be included as part of the coded video sequence(s). The additional data may be used by the video decoder (510) to properly decode the data and/or to more accurately reconstruct the original video data. Additional data can be in the form of, for example, temporal, spatial, or signal noise ratio (SNR) enhancement layers, redundant slices, redundant pictures, forward error correction codes, and so on.

**[0074]** FIG. 6 shows a block diagram of a video encoder (603) according to an embodiment of the present disclosure. The video encoder (603) is included in an electronic device (620). The electronic device (620) includes a transmitter (640) (e.g., transmitting circuitry). The video encoder (603) can be used in the place of the video encoder (403) in the FIG. 4 example.

**[0075]** The video encoder (603) may receive video samples from a video source (601) (that is not part of the electronic device (620) in the FIG. 6 example) that may capture video image(s) to be coded by the video encoder (603). In another example, the video source (601) is a part of the electronic device (620).

**[0076]** The video source (601) may provide the source video sequence to be coded by the video encoder (603) in the form of a digital video sample stream that can be of any suitable bit depth (for example: 8 bit, 10 bit, 12 bit, ...), any colorspace (for example, BT.601 Y CrCb, RGB, ...), and any suitable sampling structure (for example Y CrCb 4:2:0, Y CrCb 4:4:4). In a media serving system, the video source (601) may be a storage device storing previously prepared video. In a videoconferencing system, the video source (601) may be a camera that captures local image information as a video sequence. Video data may be provided as a plurality of individual pictures that impart motion when viewed in sequence. The pictures themselves may be organized as a spatial array of pixels, wherein each pixel can comprise one or more samples depending on the sampling structure, color space, etc. in use. A person skilled in the art can readily understand the relationship between pixels and samples. The description below focuses on samples.

**[0077]** According to an embodiment, the video encoder (603) may code and compress the pictures of the source video sequence into a coded video sequence (643) in real time or under any other time constraints as required by the application. Enforcing appropriate coding speed is one function of a controller (650). In some embodiments, the controller (650) controls other functional units as described below and is functionally coupled to the other functional units. The coupling is not depicted for clarity. Parameters set by the controller (650) can include rate control related parameters (picture skip, quantizer, lambda value of rate-distortion optimization techniques, ...), picture size, group of pictures (GOP) layout, maximum motion vector search range, and so forth. The controller (650) can be configured to have other suitable functions that pertain to the video encoder (603) optimized for a certain system design.

**[0078]** In some embodiments, the video encoder (603) is configured to operate in a coding loop. As an oversimplified description, in an example, the coding loop can include a source coder (630) (e.g., responsible for creating symbols, such as a symbol stream, based on an input picture to be coded, and a reference picture(s)), and a (local) decoder (633) embedded in the video encoder (603). The decoder (633) reconstructs the symbols to create the sample data in

a similar manner as a (remote) decoder also would create (as any compression between symbols and coded video bitstream is lossless in the video compression technologies considered in the disclosed subject matter). The reconstructed sample stream (sample data) is input to the reference picture memory (634). As the decoding of a symbol stream leads to bit-exact results independent of decoder location (local or remote), the content in the reference picture memory (634) is also bit exact between the local encoder and remote encoder. In other words, the prediction part of an encoder "sees" as reference picture samples exactly the same sample values as a decoder would "see" when using prediction during decoding. This fundamental principle of reference picture synchronicity (and resulting drift, if synchronicity cannot be maintained, for example because of channel errors) is used in some related arts as well.

**[0079]** The operation of the "local" decoder (633) can be the same as of a "remote" decoder, such as the video decoder (510), which has already been described in detail above in conjunction with FIG. 5. Briefly referring also to FIG. 5, however, as symbols are available and encoding/decoding of symbols to a coded video sequence by an entropy coder (645) and the parser (520) can be lossless, the entropy decoding parts of the video decoder (510), including the buffer memory (515), and parser (520) may not be fully implemented in the local decoder (633).

**[0080]** An observation that can be made at this point is that any decoder technology except the parsing/entropy decoding that is present in a decoder also necessarily needs to be present, in substantially identical functional form, in a corresponding encoder. For this reason, the disclosed subject matter focuses on decoder operation. The description of encoder technologies can be abbreviated as they are the inverse of the comprehensively described decoder technologies. Only in certain areas a more detail description is required and provided below.

**[0081]** During operation, in some examples, the source coder (630) may perform motion compensated predictive coding, which codes an input picture predictively with reference to one or more previously coded picture from the video sequence that were designated as "reference pictures." In this manner, the coding engine (632) codes differences between pixel blocks of an input picture and pixel blocks of reference picture(s) that may be selected as prediction reference(s) to the input picture.

**[0082]** The local video decoder (633) may decode coded video data of pictures that may be designated as reference pictures, based on symbols created by the source coder (630).

Operations of the coding engine (632) may advantageously be lossy processes. When the coded video data may be decoded at a video decoder (not shown in FIG. 6), the reconstructed video sequence typically may be a replica of the source video sequence with some errors. The local video decoder (633) replicates decoding processes that may be performed by the video decoder on reference pictures and may cause reconstructed reference pictures to be stored in the reference picture cache (634). In this manner, the video encoder (603) may store copies of reconstructed reference pictures locally that have common content as the reconstructed reference pictures that will be obtained by a far-end video decoder (absent transmission errors).

**[0083]** The predictor (635) may perform prediction searches for the coding engine (632). That is, for a new picture to be coded, the predictor (635) may search the reference picture memory (634) for sample data (as candidate reference pixel blocks) or certain metadata such as reference picture motion vectors, block shapes, and so on, that may serve as an appropriate prediction reference for the new pictures. The predictor (635) may operate on a sample block-by-pixel block basis to find appropriate prediction references. In some cases, as determined by search results obtained by the predictor (635), an input picture may have prediction references drawn from multiple reference pictures stored in the reference picture memory (634).

**[0084]** The controller (650) may manage coding operations of the source coder (630), including, for example, setting of parameters and subgroup parameters used for encoding the video data.

**[0085]** Output of all aforementioned functional units may be subjected to entropy coding in the entropy coder (645). The entropy coder (645) translates the symbols as generated by the various functional units into a coded video sequence, by lossless compressing the symbols according to technologies such as Huffman coding, variable length coding, arithmetic coding, and so forth.

**[0086]** The transmitter (640) may buffer the coded video sequence(s) as created by the entropy coder (645) to prepare for transmission via a communication channel (660), which may be a hardware/software link to a storage device which would store the encoded video data. The transmitter (640) may merge coded video data from the video coder (603) with other data to be transmitted, for example, coded audio data and/or ancillary data streams (sources not shown).

**[0087]** The controller (650) may manage operation of the video encoder (603). During coding, the controller (650) may assign to each coded picture a certain coded picture type, which

may affect the coding techniques that may be applied to the respective picture. For example, pictures often may be assigned as one of the following picture types:

**[0088]** An Intra Picture (I picture) may be one that may be coded and decoded without using any other picture in the sequence as a source of prediction. Some video codecs allow for different types of intra pictures, including, for example Independent Decoder Refresh (“IDR”) Pictures. A person skilled in the art is aware of those variants of I pictures and their respective applications and features.

**[0089]** A predictive picture (P picture) may be one that may be coded and decoded using intra prediction or inter prediction using at most one motion vector and reference index to predict the sample values of each block.

**[0090]** A bi-directionally predictive picture (B Picture) may be one that may be coded and decoded using intra prediction or inter prediction using at most two motion vectors and reference indices to predict the sample values of each block. Similarly, multiple-predictive pictures can use more than two reference pictures and associated metadata for the reconstruction of a single block.

**[0091]** Source pictures commonly may be subdivided spatially into a plurality of sample blocks (for example, blocks of 4x4, 8x8, 4x8, or 16x16 samples each) and coded on a block-by-block basis. Blocks may be coded predictively with reference to other (already coded) blocks as determined by the coding assignment applied to the blocks' respective pictures. For example, blocks of I pictures may be coded non-predictively or they may be coded predictively with reference to already coded blocks of the same picture (spatial prediction or intra prediction). Pixel blocks of P pictures may be coded predictively, via spatial prediction or via temporal prediction with reference to one previously coded reference picture. Blocks of B pictures may be coded predictively, via spatial prediction or via temporal prediction with reference to one or two previously coded reference pictures.

**[0092]** The video encoder (603) may perform coding operations according to a predetermined video coding technology or standard, such as ITU-T Rec. H.265. In its operation, the video encoder (603) may perform various compression operations, including predictive coding operations that exploit temporal and spatial redundancies in the input video sequence. The coded video data, therefore, may conform to a syntax specified by the video coding technology or standard being used.

**[0093]** In an embodiment, the transmitter (640) may transmit additional data with the encoded video. The source coder (630) may include such data as part of the coded video sequence. Additional data may comprise temporal/spatial/SNR enhancement layers, other forms of redundant data such as redundant pictures and slices, SEI messages, VUI parameter set fragments, and so on.

**[0094]** A video may be captured as a plurality of source pictures (video pictures) in a temporal sequence. Intra-picture prediction (often abbreviated to intra prediction) makes use of spatial correlation in a given picture, and inter-picture prediction makes uses of the (temporal or other) correlation between the pictures. In an example, a specific picture under encoding/decoding, which is referred to as a current picture, is partitioned into blocks. When a block in the current picture is similar to a reference block in a previously coded and still buffered reference picture in the video, the block in the current picture can be coded by a vector that is referred to as a motion vector. The motion vector points to the reference block in the reference picture, and can have a third dimension identifying the reference picture, in case multiple reference pictures are in use.

**[0095]** In some embodiments, a bi-prediction technique can be used in the inter-picture prediction. According to the bi-prediction technique, two reference pictures, such as a first reference picture and a second reference picture that are both prior in decoding order to the current picture in the video (but may be in the past and future, respectively, in display order) are used. A block in the current picture can be coded by a first motion vector that points to a first reference block in the first reference picture, and a second motion vector that points to a second reference block in the second reference picture. The block can be predicted by a combination of the first reference block and the second reference block.

**[0096]** Further, a merge mode technique can be used in the inter-picture prediction to improve coding efficiency.

**[0097]** According to some embodiments of the disclosure, predictions, such as inter-picture predictions and intra-picture predictions are performed in the unit of blocks. For example, according to the HEVC standard, a picture in a sequence of video pictures is partitioned into coding tree units (CTU) for compression, the CTUs in a picture have the same size, such as 64x64 pixels, 32x32 pixels, or 16x16 pixels. In general, a CTU includes three coding tree blocks (CTBs), which are one luma CTB and two chroma CTBs. Each CTU can be

recursively quadtree split into one or multiple coding units (CUs). For example, a CTU of 64x64 pixels can be split into one CU of 64x64 pixels, or 4 CUs of 32x32 pixels, or 16 CUs of 16x16 pixels. In an example, each CU is analyzed to determine a prediction type for the CU, such as an inter prediction type or an intra prediction type. The CU is split into one or more prediction units (PUs) depending on the temporal and/or spatial predictability. Generally, each PU includes a luma prediction block (PB), and two chroma PBs. In an embodiment, a prediction operation in coding (encoding/decoding) is performed in the unit of a prediction block. Using a luma prediction block as an example of a prediction block, the prediction block includes a matrix of values (e.g., luma values) for pixels, such as 8x8 pixels, 16x16 pixels, 8x16 pixels, 16x8 pixels, and the like.

**[0098]** FIG. 7 shows a diagram of a video encoder (703) according to another embodiment of the disclosure. The video encoder (703) is configured to receive a processing block (e.g., a prediction block) of sample values within a current video picture in a sequence of video pictures, and encode the processing block into a coded picture that is part of a coded video sequence. In an example, the video encoder (703) is used in the place of the video encoder (403) in the FIG. 4 example.

**[0099]** In an HEVC example, the video encoder (703) receives a matrix of sample values for a processing block, such as a prediction block of 8x8 samples, and the like. The video encoder (703) determines whether the processing block is best coded using intra mode, inter mode, or bi-prediction mode using, for example, rate-distortion optimization. When the processing block is to be coded in intra mode, the video encoder (703) may use an intra prediction technique to encode the processing block into the coded picture; and when the processing block is to be coded in inter mode or bi-prediction mode, the video encoder (703) may use an inter prediction or bi-prediction technique, respectively, to encode the processing block into the coded picture. In certain video coding technologies, merge mode can be an inter picture prediction submode where the motion vector is derived from one or more motion vector predictors without the benefit of a coded motion vector component outside the predictors. In certain other video coding technologies, a motion vector component applicable to the subject block may be present. In an example, the video encoder (703) includes other components, such as a mode decision module (not shown) to determine the mode of the processing blocks.

**[0100]** In the FIG. 7 example, the video encoder (703) includes the inter encoder (730), an intra encoder (722), a residue calculator (723), a switch (726), a residue encoder (724), a general controller (721), and an entropy encoder (725) coupled together as shown in FIG. 7.

**[0101]** The inter encoder (730) is configured to receive the samples of the current block (e.g., a processing block), compare the block to one or more reference blocks in reference pictures (e.g., blocks in previous pictures and later pictures), generate inter prediction information (e.g., description of redundant information according to inter encoding technique, motion vectors, merge mode information), and calculate inter prediction results (e.g., predicted block) based on the inter prediction information using any suitable technique. In some examples, the reference pictures are decoded reference pictures that are decoded based on the encoded video information.

**[0102]** The intra encoder (722) is configured to receive the samples of the current block (e.g., a processing block), in some cases compare the block to blocks already coded in the same picture, generate quantized coefficients after transform, and in some cases also intra prediction information (e.g., an intra prediction direction information according to one or more intra encoding techniques). In an example, the intra encoder (722) also calculates intra prediction results (e.g., predicted block) based on the intra prediction information and reference blocks in the same picture.

**[0103]** The general controller (721) is configured to determine general control data and control other components of the video encoder (703) based on the general control data. In an example, the general controller (721) determines the mode of the block, and provides a control signal to the switch (726) based on the mode. For example, when the mode is the intra mode, the general controller (721) controls the switch (726) to select the intra mode result for use by the residue calculator (723), and controls the entropy encoder (725) to select the intra prediction information and include the intra prediction information in the bitstream; and when the mode is the inter mode, the general controller (721) controls the switch (726) to select the inter prediction result for use by the residue calculator (723), and controls the entropy encoder (725) to select the inter prediction information and include the inter prediction information in the bitstream.

**[0104]** The residue calculator (723) is configured to calculate a difference (residue data) between the received block and prediction results selected from the intra encoder (722) or the inter encoder (730). The residue encoder (724) is configured to operate based on the residue data

to encode the residue data to generate the transform coefficients. In an example, the residue encoder (724) is configured to convert the residue data from a spatial domain to a frequency domain, and generate the transform coefficients. The transform coefficients are then subject to quantization processing to obtain quantized transform coefficients. In various embodiments, the video encoder (703) also includes a residue decoder (728). The residue decoder (728) is configured to perform inverse-transform, and generate the decoded residue data. The decoded residue data can be suitably used by the intra encoder (722) and the inter encoder (730). For example, the inter encoder (730) can generate decoded blocks based on the decoded residue data and inter prediction information, and the intra encoder (722) can generate decoded blocks based on the decoded residue data and the intra prediction information. The decoded blocks are suitably processed to generate decoded pictures and the decoded pictures can be buffered in a memory circuit (not shown) and used as reference pictures in some examples.

**[0105]** The entropy encoder (725) is configured to format the bitstream to include the encoded block. The entropy encoder (725) is configured to include various information according to a suitable standard, such as the HEVC standard. In an example, the entropy encoder (725) is configured to include the general control data, the selected prediction information (e.g., intra prediction information or inter prediction information), the residue information, and other suitable information in the bitstream. Note that, according to the disclosed subject matter, when coding a block in the merge submode of either inter mode or bi-prediction mode, there is no residue information.

**[0106]** FIG. 8 shows a diagram of a video decoder (810) according to another embodiment of the disclosure. The video decoder (810) is configured to receive coded pictures that are part of a coded video sequence, and decode the coded pictures to generate reconstructed pictures. In an example, the video decoder (810) is used in the place of the video decoder (410) in the FIG. 4 example.

**[0107]** In the FIG. 8 example, the video decoder (810) includes an entropy decoder (871), an inter decoder (880), a residue decoder (873), a reconstruction module (874), and an intra decoder (872) coupled together as shown in FIG. 8.

**[0108]** The entropy decoder (871) can be configured to reconstruct, from the coded picture, certain symbols that represent the syntax elements of which the coded picture is made up. Such symbols can include, for example, the mode in which a block is coded (such as, for

example, intra mode, inter mode, bi-predicted mode, the latter two in merge submode or another submode), prediction information (such as, for example, intra prediction information or inter prediction information) that can identify certain sample or metadata that is used for prediction by the intra decoder (872) or the inter decoder (880), respectively, residual information in the form of, for example, quantized transform coefficients, and the like. In an example, when the prediction mode is inter or bi-predicted mode, the inter prediction information is provided to the inter decoder (880); and when the prediction type is the intra prediction type, the intra prediction information is provided to the intra decoder (872). The residual information can be subject to inverse quantization and is provided to the residue decoder (873).

**[0109]** The inter decoder (880) is configured to receive the inter prediction information, and generate inter prediction results based on the inter prediction information.

**[0110]** The intra decoder (872) is configured to receive the intra prediction information, and generate prediction results based on the intra prediction information.

**[0111]** The residue decoder (873) is configured to perform inverse quantization to extract de-quantized transform coefficients, and process the de-quantized transform coefficients to convert the residual from the frequency domain to the spatial domain. The residue decoder (873) may also require certain control information (to include the Quantizer Parameter (QP)), and that information may be provided by the entropy decoder (871) (data path not depicted as this may be low volume control information only).

**[0112]** The reconstruction module (874) is configured to combine, in the spatial domain, the residual as output by the residue decoder (873) and the prediction results (as output by the inter or intra prediction modules as the case may be) to form a reconstructed block, that may be part of the reconstructed picture, which in turn may be part of the reconstructed video. It is noted that other suitable operations, such as a deblocking operation and the like, can be performed to improve the visual quality.

**[0113]** It is noted that the video encoders (403), (603), and (703), and the video decoders (410), (510), and (810) can be implemented using any suitable technique. In an embodiment, the video encoders (403), (603), and (703), and the video decoders (410), (510), and (810) can be implemented using one or more integrated circuits. In another embodiment, the video encoders (403), (603), and (603), and the video decoders (410), (510), and (810) can be implemented using one or more processors that execute software instructions.

**[0114]** The disclosure includes improvements on decoder side intra mode derivation (DIMD).

**[0115]** ITU-T VCEG (Q6/16) and ISO/IEC MPEG (JTC 1/SC 29/WG 11) published the H.265/HEVC (High Efficiency Video Coding) standard in 2013 (version 1), 2014 (version 2), 2015 (version 3), and 2016 (version 4). In 2015, these two standard organizations jointly formed the JVET (Joint Video Exploration Team) to explore the potential of developing the next video coding standard beyond HEVC. In April 2018, JVET formally launched the standardization process of next-generation video coding beyond HEVC. The new standard was named Versatile Video Coding (VVC), and JVET was renamed as Joint Video Expert Team. In July 2020, H.266/VVC version 1 was finalized. In January 2021, an ad hoc group was established to investigate enhanced compression beyond VVC capability.

**[0116]** In VVC, results of intra predictions based on DC, planar, and several angular modes can be further modified by a position dependent intra prediction combination (PDPC) method. PDPC is an intra prediction method which can invoke a combination of boundary reference samples and a HEVC style intra prediction with filtered boundary reference samples. PDPC can be applied to the following intra modes without signaling: planar, DC, intra angles less than or equal to horizontal, and intra angles (i) greater than or equal to vertical and (ii) less than or equal to 80. If a current block is under a block-based delta pulse code modulation (BDPCM) mode, the PDPC may not be applied. If the current block is under a multiple reference line (MRL) intra prediction mode and the MRL index is larger than 0, the PDPC may not be applied.

**[0117]** According to PDPC, a prediction sample (e.g.,  $pred(x',y')$ ) of a current sample ( $x, y$ ) can be predicted using an intra prediction mode (e.g., DC, planar, or angular) and a linear combination of reference samples of the current block according to the Equation 1 is as follows:

$$pred(x',y') = \text{Clip}(0, (1 \ll \text{BitDepth}) - 1, (wL \times R_{-1,y'} + wT \times R_{x',-1} + (64 - wL - wT) \times pred(x',y') + 32) \gg 6) \quad \text{Eq. (1)}$$

where  $R_{x',-1}$  and  $R_{-1,y'}$  can represent reference samples located at the top and left boundaries of the current sample ( $x, y$ ), respectively.  $wL$  and  $wT$  can be the weights for the reference samples  $R_{-1,y'}$  and  $R_{x',-1}$ , respectively.

**[0118]** If PDPC is applied to DC, planar, horizontal, and vertical intra modes, additional boundary filters may not be required. However, the additional boundary filters, such as a DC

mode boundary filter or horizontal/vertical mode edge filters, may be required in HEVC, for example. The additional boundary filters can be a DC mode boundary filter or a horizontal/vertical mode edge filter. The PDPC process for a DC mode and a Planar mode can be identical. For angular modes, if the current angular mode is horizontal (e.g., HOR\_IDX) or vertical (e.g., VER\_IDX), left or top reference samples may not be used, respectively. The PDPC weights and scale factors can depend on prediction modes and the block sizes. PDPC can be applied to a block with both a width and a height greater than or equal to 4.

**[0119]** FIGS. 9A-9D shows exemplary definitions of reference samples ( $R_{(x,-1)}$  and  $R_{(-1,y)}$ ) for PDPC. The prediction sample  $pred(x', y')$  can be located at  $(x', y')$  within a prediction block 902.  $R_{(-1,y)}$ ,  $R_{(x,-1)}$ , and  $R_{(-1,-1)}$  can represent the reference samples located at the left, top, and top-left of the prediction block 902, respectively. FIG. 9A shows a diagonal top-right mode of the PDPC. FIG. 9B shows a diagonal bottom-left mode of the PDPC. FIG. 9C shows an adjacent diagonal top-right mode of the PDPC. FIG. 9D shows an adjacent diagonal bottom-left mode of the PDPC. In an example, such as shown in FIG. 9A, the coordinate  $x$  of the reference sample  $R_{(x,-1)}$  can be given by:  $x = x' + y' + 1$ , and the coordinate  $y$  of the reference sample  $R_{(-1,y)}$  can be given by:  $y = x' + y' + 1$  for the diagonal modes. For other angular modes, such as shown in FIGS. 9C and 9D, the reference samples  $R_{(x,-1)}$  and  $R_{(-1,y)}$  can be located in a fractional sample position. When the reference samples  $R_{(x,-1)}$  and  $R_{(-1,y)}$  are located in a fractional sample position, the sample value of a nearest integer sample location can be used.

**[0120]** In some embodiments, a gradient based PDPC can be applied when PDPC may not be applied due to the unavailability of a secondary reference sample, such as the reference sample  $R_{(x,-1)}$ . The gradient based PDPC, such as provided in JVET-Q0391, can be an intra prediction mode extended from a horizontal/vertical mode. Accordingly, the PDPC weights (e.g.,  $w_T$  and  $w_L$ ) and a scale parameter (e.g.,  $nScale$ ) for determining a decay in the PDPC weights with respect to a distance from the left/top boundary can be set equal to corresponding parameters in the horizontal/vertical mode, respectively. When the secondary reference sample is located at a fractional sample position, a bilinear interpolation can be applied.

**[0121]** In DIMD, an intra mode can be derived using relevant syntax elements signaled in the bitstream, or the intra mode can be derived in the decoder side without using relevant syntax elements signaled in the bitstream. A number of methods can be used to derive the intra mode in

the decoder side, and the expression “decoder side intra mode derivation” is not limited to methods described in the disclosure.

**[0122]** In DIMD, two intra modes from a plurality of candidate intra modes for a current CU/PU can be derived from the reconstructed neighbor samples of the current CU/PU. A texture gradient analysis can be performed at both encoder and decoder sides to generate the plurality of candidate intra modes based on the reconstructed neighbor samples. Each of the plurality of candidate intra modes can be associated with a respective history of gradient (or a respective gradient). The two intra modes (e.g., `intraMode1` and `intraMode2`) with highest history of gradients (or with highest gradients in a histogram diagram) can be selected. Intra mode predictors of the selected two intra modes (e.g., `intraMode1` and `intraMode2`) can be combined with the planar mode predictor using a weighted sum. A final intra mode predictor for the current CU/PU can be formed based on a combination of `intraMode1`, `intraMode2`, and planar.

**[0123]** Table 1 shows an exemplary DIMD signaling process. As shown in Table 1, a DIMD flag (e.g., `DIMD_flag`) can be signaled before an ISP flag (e.g., `ISP_flag`). When DIMD flag is 1 (or true), it can indicate that the current CU/PU uses DIMD, and the ISP flag can further be parsed to verify whether ISP is applied for the current CU/PU. When DIMD flag is not 1 (or false), it can indicate that the current CU/PU does not use DIMD. Accordingly, syntax elements related to other intra coding tools (e.g., MIP, MRL, MPM, and so on) can be parsed in the decoder.

**[0124]** The context modeling of DIMD flag can depend on an adjacent CU/PU. For example, the context modeling of the DIMD flag can depend on (i) the availability of a left adjacent CU/PU or an above adjacent CU/PU and (ii) whether the left adjacent CU/PU or the above adjacent CU/PU also uses DIMD. If either the left adjacent CU/PU or the above adjacent CU/PU exists and uses DIMD, a context index (e.g., `ctxIdx`) can be 1. When both the left adjacent CU/PU and the above adjacent CU/PU exist and use DIMD, the context index (e.g., `ctxIdx`) can be 2. Otherwise, the context index (e.g., `ctxIdx`) can be 0.

Table 1. Pseudo code of DIMD signaling

...
Parse <code>DIMD_flag</code>

If DIMD_flag is 1
Parse ISP_flag
If ISP_flag is 1
Parse ISP related syntax element
Else parse other intra related syntax element
...

**[0125]** An exemplary fusion process (1000) of intraMode1, intraMode2, and planar based on DIMD is illustrated in FIG. 10. As shown in FIG. 10, a 1<sup>st</sup> intra mode (e.g., intraMode1) and a 2<sup>nd</sup> intra mode (e.g., intraMode2) can be obtained based on DIMD. Further, a first angular prediction (1002) can be obtained based on the 1<sup>st</sup> intra mode, a second angular prediction (1004) can be obtained based on the 2<sup>nd</sup> intra mode, and a third prediction (1006) can be obtained based on a 3<sup>rd</sup> intra mode (e.g., a planar mode). When PDPC is applicable, a first PDPC process (1008) can be applied to the first prediction (1002) to generate a refined first prediction. A second PDPC process (1010) can be applied to the second prediction (1004) to generate a refined second prediction. Although PDPC applicable can be applicable to the Planar mode, PDPC may not be applied in the fusion process (1000). A fusion process (1012) can be performed to generate a weighted combination of the refined first prediction, the refined second prediction, and the third prediction.

**[0126]** Template-based intra mode derivation (TIMD) can use reference samples of a current CU as a template and select an intra mode among a set of candidate intra prediction modes that is associated with TIMD. The selected intra mode may be determined as a best intra mode based on a cost function, for example. As shown in FIG. 11, neighboring reconstructed samples of the current CU (1102) can be used as a template (1104). Reconstructed samples in the template (1104) can be compared with prediction samples of the template (1104). The prediction samples can be generated using reference samples (1106) of the template (1104). The reference samples (1106) can be neighboring reconstructed samples around the template (1104). A cost function (e.g., sum of absolute difference (SAD) or sum of absolute transformed difference (SATD)) can be used to calculate a cost (or distortion) between the prediction samples

and the reconstructed samples in the template (1104) based on a respective one of the set of candidate intra prediction modes. An intra prediction mode with a minimum cost (or distortion) can be selected as the intra prediction mode (e.g., best intra prediction mode) to inter predict the current CU (1102).

**[0127]** Table 2 shows an exemplary coding process associated with TIMD. As shown in Table 2, a TIMD flag (e.g., TIMD\_flag) can be signaled when a DIMD flag (e.g., DIMD\_flag) is not 1 (or not true). When DIMD flag is 1 (or true), the current CU/PU uses DIMD, and an ISP flag (e.g., ISP\_flag) can be parsed to determine if ISP is used for the current CU/PU. When DIMD flag is not 1 (or false), TIMD flag can be parsed. When TIMD flag is 1, TIMD can be applied to the current CU/PU without applying other intra coding tools (e.g., ISP is not allowed when TIMD is used). When TIMD flag is not 1 (or false), syntax elements related to other intra coding tools (e.g., MIP, MRL, MPM, and so on) can be parsed in the decoder.

Table 2. Pseudo code of TIMD signaling

...
Parse DIMD_flag
If DIMD_flag is 1
Parse ISP_flag
If ISP_flag is 1
Parse ISP related syntax element
Else parse TIMD_flag
If TIMD_flag is 1, decoder do TIMD
Else parse other intra related syntax element
...

**[0128]** According to TIMD, the first two intra prediction modes with the minimum SATD can be selected as the TIMD modes. These two TIMD modes can be fused with weights to generate a weighted intra prediction. The weighted intra prediction can be used to code the current CU. PDPC can also be included in the derivation of the TIMD modes.

**[0129]** The costs (or cost values) of the two selected modes (e.g., intramode1 and intraMode2) can be compared with a threshold, where a cost factor of 2 can be applied in Equation 2 as follows:

$$\text{costMode2} < 2 * \text{costMode1}. \quad \text{Eq. (2)}$$

where costMode 2 is a cost value (e.g., SAD or SATD) obtained based on the intramode 2, and costMode 1 is a cost value obtained based on the intramode 1. If the condition shown in Equation 2 is true, a fusion process can be applied to generate a weighted intra prediction. Otherwise, only intramode1 can be used. Weights of the selected modes (e.g., intramode1 and intraMode2) can be computed from costs (e.g., SAD or SATD) of the selected modes. For example, the weights of the selected modes can be shown in Equations 3 and 4 as follows:

$$\text{weight1} = \text{costMode2} / (\text{costMode1} + \text{costMode2}) \quad \text{Eq. (3)}$$

$$\text{weight2} = 1 - \text{weight1} \quad \text{Eq. (4)}$$

**[0130]** FIG. 12 shows a TIMD mode with fusion. As shown in FIG. 12, a first prediction (1202) for a current block can be generated based on a 1<sup>st</sup> intra mode (e.g., intraMode1) and a second prediction (1204) for the current block can be generated based on a 2<sup>nd</sup> intra mode (e.g., intraMode2). The 1<sup>st</sup> intra mode and the 2<sup>nd</sup> intra mode can be obtained based on TIMD. At step (S1206), when the 1<sup>st</sup> intra mode is an angular mode, a PDPC process (1210) can apply to the first prediction (1202) to generate a refined first prediction. At step (S1208), when the 2<sup>nd</sup> intra mode is an angular mode, the second prediction (1204) can receive a PDPC process (1212) to generate a refined second prediction. The refined first prediction and the refined second prediction can be fused, or combined, at (1214) to generate a first combined prediction. The first combined prediction can be a weighted combination of the refined first prediction and the refined second prediction. In response to the 1<sup>st</sup> intra mode being a DC mode or a planar mode, a PDPC process (1218) can apply to the first combined prediction to generate a second combined prediction. Further, the current block can be intra predicted based on the second combined prediction.

**[0131]** Still referring to FIG. 12, at the step (S1206), when the 1<sup>st</sup> intra mode is not an angular mode, the PDPC process (1210) may not apply to the first prediction (1202). Similarly, at the step (S1208), the 2<sup>nd</sup> intra mode is not an angular mode, the PDPC process (1212) may not

apply to the second prediction (1204). Further, when the 1<sup>st</sup> intra mode is not the DC mode or the planar mode, the PDPC process (1218) may not apply to the first combined prediction.

**[0132]** Decoder side intra prediction can use an explicitly signaled intra mode and a decoder side derived intra mode to perform an intra prediction at a decoder side. For example, the decoder can apply DIMD to derive an intra mode and use the derived intra mode for intra prediction.

**[0133]** In the disclosure, an PDPC process can be performed after a fusion process, such as a DIMD fusion process. An exemplary process (1300) can be provided in FIG. 13. As shown in FIG. 13, a first predictor (1302) can be generated by performing an intra prediction on a current block based on a first intra mode (e.g., intraMode 1), a second predictor (1304) can be generated by performing an intra prediction on the current block based on a second intra mode (e.g., intraMode 2), and a third predictor (1306) can be generated by performing an intra prediction on the current block based on a planar mode. The first intra mode and the second intra mode can be obtained based on DIMD. The first, second, and third predictors can be combined by a fusion process (1308) to generate a combined predictor. The combined predictor can be a weighted combination of the first, second, and third predictors. A PDPC process (1310) can apply to the combined predictor to generate a refined predictor. Thus, the current block can be reconstructed based on the refined predictor at a decoder side.

**[0134]** It should be noted that FIG. 13 is merely an example. The number of predictors is not limited to three. Any number of predictors can be applied in the process (1300). In addition, the PDPC process can include the gradient based PDPC that is mentioned above. The gradient based PDPC can be implemented without the secondary reference sample.

**[0135]** To determine whether the PDPC process can be applied, in an embodiment, only one intra mode or predictor is used to determine whether the PDPC process is applied. For example, the first intra mode (e.g., intraMode1) can be used to determine whether the PDPC process is applicable in the process (1300).

**[0136]** In another embodiment, an average value of intra angular modes can be used to determine whether the PDPC process is applied. When the first intra mode and the second intra mode are angular modes, an average of angular values of the first intra mode and the second intra mode can be used to determine whether the PDPC process is applicable in the process (1300). For example, when the first intra mode (e.g., intraMode1) is an intra angular mode 60 and the

second intra mode (e.g., intraMode2) is an intra angular mode 62, the average angular value of the first intra mode and the second intra mode is  $(60+62)\ggg1=61$ . When PDPC is applicable to the intra angular mode 61, the PDPC process (1310) can be applied after the fusion process (1308) in process (1300).

**[0137]** In another example, when only one of the first intra mode and the second intra mode is an intra angular mode, whether the PDPC process is applicable can be determined based on the one of the first intra mode and the second intra mode that is the intra angular mode.

**[0138]** In yet another embodiment, the PDPC process may be determined as applicable for certain predictors, such as a Planar or a DC predictor. For example, when one of the first intra mode and the second intra mode is a planar mode or a DC mode, the PDPC process can always be applicable in process (1300).

**[0139]** In the disclosure, a PDPC process can be performed after a TIMD fusion process. An exemplary process (1400) can be shown in FIG. 14. As shown in FIG. 14, a first predictor (1402) can be generated by performing an intra prediction on a current block based on a first intra mode (e.g., intraMode 1) and a second predictor (1404) can be generated by performing an intra prediction on the current block based on a second intra mode (e.g., intraMode 2). The first intra mode and the second intra mode can be obtained based on TIMD. The first and second predictors can be combined by a fusion process (1406) to generate a combined predictor. The combined predictor can be a weighted combination of the first and second predictors. A PDPC process (1408) can apply to the combined predictor to generate a refined predictor. Thus, the current block can be reconstructed based on the refined predictor at a decoder side.

**[0140]** It should be noted that the process (1400) can include any number of predictors. Further, the PDPC process can include the gradient based PDPC that can be implemented without the secondary reference sample.

**[0141]** To determine whether the PDPC process can be applied, in an embodiment, only one intra mode or predictor is used to determine whether the PDPC process is applied. For example, the first intra mode (e.g., intraMode1) can be used to determine whether the PDPC process is applicable in the process (1400).

**[0142]** In another embodiment, an average value of intra angular modes can be used to determine whether the PDPC process is applied. When the first intra mode and the second intra

mode are angular modes, an average of angular values of the first intra mode and the second intra mode can be used to determine whether the PDPC process is applicable in the process (1400).

**[0143]** For example, when the first intra mode (e.g., *intraMode1*) is an intra angular mode 60 and the second intra mode (e.g., *intraMode2*) is an intra angular mode 62, the average angular value of the first intra mode and the second intra mode is  $(60+62)/2=61$ . When the intra angular mode 61 is PDPC applicable, the PDPC process (1408) can be applied after the fusion process (1406) in process (1400).

**[0144]** In another example, when only one of the first intra mode and the second intra mode is an intra angular mode, whether the PDPC process is applicable can be determined based on the one of the first intra mode and the second intra mode that is the intra angular mode.

**[0145]** In yet another embodiment, the PDPC process may be determined as applicable for certain predictors, such as a Planar or a DC predictor. For example, when one of the first intra mode and the second intra mode is a planar mode or a DC mode, the PDPC process can always be applicable in process (1400).

**[0146]** In the disclosure, the PDPC process can be skipped after the fusion process. For example the PDPC process can be skipped for DIMD and/or TIMD. FIG. 15A shows an exemplary process (1500A) in which a final intra predictor can be generated by performing a fusion process on a first predictor (1502), a second predictor (1504), and a third predictor (1506). The first predictor (1502) can be obtained based on a first intra mode, the second predictor (1504) can be obtained based on a second intra mode, and the third predictor (1506) can be obtained based on a planar mode. The first intra mode and the second intra mode can be generated based on DIMD.

**[0147]** FIG. 15B shows an exemplary process (1500B) in which a final intra predictor can be generated by performing a fusion process on a first predictor (1510) and a second predictor (1512). The first predictor (1510) can be obtained based on a first intra mode and the second predictor (1512) can be obtained based on a second intra mode. The first intra mode and the second intra mode can be generated based on the TIMD.

**[0148]** It should be noted that the number of predictors shown in FIGS. 15A and 15B for fusion is not limited to three or two and can be any number.

**[0149]** FIG. 16 shows a flow chart outlining an exemplary decoding process (1600) according to some embodiments of the disclosure. FIG. 17 shows a flow chart outlining an

exemplary encoding process (1700) according to some embodiments of the disclosure. The proposed processes may be used separately or combined in any order. Further, each of the processes (or embodiments), encoder, and decoder may be implemented by processing circuitry (e.g., one or more processors or one or more integrated circuits). In one example, the one or more processors execute a program that is stored in a non-transitory computer-readable medium.

**[0150]** In embodiments, any operations of processes (e.g., (1600) and (1700)) may be combined or arranged in any amount or order, as desired. In embodiments, two or more of the operations of the processes (e.g., (1600) and (1700)) may be performed in parallel.

**[0151]** The processes (e.g., (1600) and (1700)) can be used in the reconstruction and/or encoding of a block, so as to generate a prediction block for the block under reconstruction. In various embodiments, the processes (e.g., (1600) and (1700)) are executed by processing circuitry, such as the processing circuitry in the terminal devices (310), (320), (330) and (340), the processing circuitry that performs functions of the video encoder (403), the processing circuitry that performs functions of the video decoder (410), the processing circuitry that performs functions of the video decoder (510), the processing circuitry that performs functions of the video encoder (503), and the like. In some embodiments, the processes (e.g., (1600) and (1700)) are implemented in software instructions, thus when the processing circuitry executes the software instructions, the processing circuitry performs the processes (e.g., (1600) and (1700)).

**[0152]** As shown in FIG. 16, the process (1600) can start from (S1601) and proceed to (S1610). At (S1610), coded information of a current block and neighboring samples of the current block can be received from a coded video bitstream.

**[0153]** At (S1620), one or more intra mode predictors of the current block can be determined, where the one or more intra mode predictors can be derived based on the neighboring samples of the current block via either a DIMD or a TIMD.

**[0154]** At (S1630), whether a PDPC is to be applied can be determined based on the one or more intra mode predictors.

**[0155]** At (S1640), in response to the determining that the PDPC is to be applied, a fusion process can be performed on the one or more intra mode predictors, where the fusion process can combine the one or more intra mode predictors to generate a single intra mode predictor.

**[0156]** At (S1650), the PDPC can be applied based on the single intra mode predictor to generate a modified predictor of the current block subsequent to the fusion process on the one or more intra mode predictors.

**[0157]** At (S1660), the current block can be reconstructed based on the modified predictor generated by the PDPC.

**[0158]** In some embodiments, the fusion process can include generating the single intra mode predictor based on a weighted combination of the one or more intra mode predictors. In some embodiments, the PDPC further can include generating the modified predictor based on a weighted combination of (i) one or more neighboring samples of the neighboring samples and (ii) the single intra mode predictor.

**[0159]** In response to the one or more intra mode predictors being derived based on the DIMD, a first intra mode predictor of the one or more intra mode predictors can be determined based on a first intra mode. The first intra mode can be determined based on the neighboring samples and associated with a highest HoG of the neighboring samples. A second intra mode predictor of the one or more intra mode predictors can be determined based on a second intra mode. The second intra mode can be determined based on the neighboring samples and associated with a second highest HoG of the neighboring samples. A third intra mode predictor of the one or more intra mode predictors can be determined based on a planar mode.

**[0160]** In some embodiments, whether the PDPC is applicable can be determined based on the first intra mode that is derived based on the DIMD.

**[0161]** In response to the first intra mode and the second intra mode being angular modes, whether the PDPC is applicable can be determined based on an average angular value of the first intra mode and the second intra mode. In response to one of the first intra mode and the second intra mode being an angular mode, whether the PDPC is applicable can be determined based on the one of the first intra mode and the second intra mode that is the angular mode.

**[0162]** In some embodiments, the PDPC can be determined to be applicable in response to at least one of the one or more intra mode predictors being generated based on a planar mode or a DC mode.

**[0163]** In response to the one or more intra mode predictors being derived based on the TIMD, a first intra mode predictor of the one or more intra mode predictors can be determined based on a first intra mode, where the first intra mode can be determined based on the

neighboring samples and associated with a smallest cost value of the neighboring samples. A second intra mode predictor of the one or more intra mode predictors can be determined based on a second intra mode, where the second intra mode can be determined based on the neighboring samples and associated with a second smallest cost value of the neighboring samples.

**[0164]** In some embodiments, whether the PDPC is applicable can be determined based on the first intra mode that is derived based on the TIMD.

**[0165]** In response to the first intra mode and the second intra mode being angular modes, whether the PDPC is applicable can be determined based on an average angular value of the first intra mode and the second intra mode. In response to one of the first intra mode and the second intra mode being an angular mode, whether the PDPC is applicable can be determined based on the one of the first intra mode and the second intra mode that is the angular mode.

**[0166]** In some embodiments, the PDPC can be determined to be applicable in response to at least one of the first intra mode and the second intra mode being a planar mode or a DC mode.

**[0167]** As shown in FIG. 17, the process (1700) can start from (S1701) and proceed to (S1710). At (S1710), one or more intra mode predictors of a current block can be determined, where the one or more intra mode predictors can be derived based on neighboring samples of the current block via either a DIMD or a TIMD.

**[0168]** At (S1720), whether a PDPC is to be applied can be determined based on the one or more intra mode predictors.

**[0169]** At (S1730), in response to the determining that the PDPC is to be applied, a fusion process can be performed on the one or more intra mode predictors. The fusion process can combine the one or more intra mode predictors to generate a single intra mode predictor.

**[0170]** At (S1740), the PDPC can be applied based on the single intra mode predictor to generate a modified predictor of the current block subsequent to the fusion process on the one or more intra mode predictors.

**[0171]** At (S1750), an intra prediction can be performed on the current block based on the modified predictor.

**[0172]** At (S1760), a coded bitstream can be generated to include coded information of the current block and the neighboring samples of the current block.

**[0173]** The techniques described above, can be implemented as computer software using computer-readable instructions and physically stored in one or more computer-readable media. For example, FIG. 18 shows a computer system (1800) suitable for implementing certain embodiments of the disclosed subject matter.

**[0174]** The computer software can be coded using any suitable machine code or computer language, that may be subject to assembly, compilation, linking, or like mechanisms to create code comprising instructions that can be executed directly, or through interpretation, micro-code execution, and the like, by one or more computer central processing units (CPUs), Graphics Processing Units (GPUs), and the like.

**[0175]** The instructions can be executed on various types of computers or components thereof, including, for example, personal computers, tablet computers, servers, smartphones, gaming devices, internet of things devices, and the like.

**[0176]** The components shown in FIG. 18 for computer system (1800) are exemplary in nature and are not intended to suggest any limitation as to the scope of use or functionality of the computer software implementing embodiments of the present disclosure. Neither should the configuration of components be interpreted as having any dependency or requirement relating to any one or combination of components illustrated in the exemplary embodiment of a computer system (1800).

**[0177]** Computer system (1800) may include certain human interface input devices. Such a human interface input device may be responsive to input by one or more human users through, for example, tactile input (such as: keystrokes, swipes, data glove movements), audio input (such as: voice, clapping), visual input (such as: gestures), olfactory input (not depicted). The human interface devices can also be used to capture certain media not necessarily directly related to conscious input by a human, such as audio (such as: speech, music, ambient sound), images (such as: scanned images, photographic images obtain from a still image camera), video (such as two-dimensional video, three-dimensional video including stereoscopic video).

**[0178]** Input human interface devices may include one or more of (only one of each depicted): keyboard (1801), mouse (1802), trackpad (1803), touch screen (1810), data-glove (not shown), joystick (1805), microphone (1806), scanner (1807), camera (1808).

**[0179]** Computer system (1800) may also include certain human interface output devices. Such human interface output devices may be stimulating the senses of one or more human users

through, for example, tactile output, sound, light, and smell/taste. Such human interface output devices may include tactile output devices (for example tactile feedback by the touch-screen (1810), data-glove (not shown), or joystick (1805), but there can also be tactile feedback devices that do not serve as input devices), audio output devices (such as: speakers (1809), headphones (not depicted)), visual output devices (such as screens (1810) to include CRT screens, LCD screens, plasma screens, OLED screens, each with or without touch-screen input capability, each with or without tactile feedback capability—some of which may be capable to output two dimensional visual output or more than three dimensional output through means such as stereographic output; virtual-reality glasses (not depicted), holographic displays and smoke tanks (not depicted)), and printers (not depicted).

**[0180]** Computer system (1800) can also include human accessible storage devices and their associated media such as optical media including CD/DVD ROM/RW (1820) with CD/DVD or the like media (1821), thumb-drive (1822), removable hard drive or solid state drive (1823), legacy magnetic media such as tape and floppy disc (not depicted), specialized ROM/ASIC/PLD based devices such as security dongles (not depicted), and the like.

**[0181]** Those skilled in the art should also understand that term “computer readable media” as used in connection with the presently disclosed subject matter does not encompass transmission media, carrier waves, or other transitory signals.

**[0182]** Computer system (1800) can also include an interface (1854) to one or more communication networks (1855). Networks can for example be wireless, wireline, optical. Networks can further be local, wide-area, metropolitan, vehicular and industrial, real-time, delay-tolerant, and so on. Examples of networks include local area networks such as Ethernet, wireless LANs, cellular networks to include GSM, 3G, 4G, 5G, LTE and the like, TV wireline or wireless wide area digital networks to include cable TV, satellite TV, and terrestrial broadcast TV, vehicular and industrial to include CANBus, and so forth. Certain networks commonly require external network interface adapters that attached to certain general purpose data ports or peripheral buses (1849) (such as, for example USB ports of the computer system (1800)); others are commonly integrated into the core of the computer system (1800) by attachment to a system bus as described below (for example Ethernet interface into a PC computer system or cellular network interface into a smartphone computer system). Using any of these networks, computer system (1800) can communicate with other entities. Such communication can be uni-directional,

receive only (for example, broadcast TV), uni-directional send-only (for example CANbus to certain CANbus devices), or bi-directional, for example to other computer systems using local or wide area digital networks. Certain protocols and protocol stacks can be used on each of those networks and network interfaces as described above.

**[0183]** Aforementioned human interface devices, human-accessible storage devices, and network interfaces can be attached to a core (1840) of the computer system (1800).

**[0184]** The core (1840) can include one or more Central Processing Units (CPU) (1841), Graphics Processing Units (GPU) (1842), specialized programmable processing units in the form of Field Programmable Gate Areas (FPGA) (1843), hardware accelerators for certain tasks (1844), graphics adapters (1850), and so forth. These devices, along with Read-only memory (ROM) (1845), Random-access memory (1846), internal mass storage such as internal non-user accessible hard drives, SSDs, and the like (1847), may be connected through a system bus (1848). In some computer systems, the system bus (1848) can be accessible in the form of one or more physical plugs to enable extensions by additional CPUs, GPU, and the like. The peripheral devices can be attached either directly to the core's system bus (1848), or through a peripheral bus (1849). In an example, the screen (1810) can be connected to the graphics adapter (1850). Architectures for a peripheral bus include PCI, USB, and the like.

**[0185]** CPUs (1841), GPUs (1842), FPGAs (1843), and accelerators (1844) can execute certain instructions that, in combination, can make up the aforementioned computer code. That computer code can be stored in ROM (1845) or RAM (1846). Transitional data can be also be stored in RAM (1846), whereas permanent data can be stored for example, in the internal mass storage (1847). Fast storage and retrieve to any of the memory devices can be enabled through the use of cache memory, that can be closely associated with one or more CPU (1841), GPU (1842), mass storage (1847), ROM (1845), RAM (1846), and the like.

**[0186]** The computer readable media can have computer code thereon for performing various computer-implemented operations. The media and computer code can be those specially designed and constructed for the purposes of the present disclosure, or they can be of the kind well known and available to those having skill in the computer software arts.

**[0187]** As an example and not by way of limitation, the computer system having architecture (1800), and specifically the core (1840) can provide functionality as a result of processor(s) (including CPUs, GPUs, FPGA, accelerators, and the like) executing software

embodied in one or more tangible, computer-readable media. Such computer-readable media can be media associated with user-accessible mass storage as introduced above, as well as certain storage of the core (1840) that are of non-transitory nature, such as core-internal mass storage (1847) or ROM (1845). The software implementing various embodiments of the present disclosure can be stored in such devices and executed by core (1840). A computer-readable medium can include one or more memory devices or chips, according to particular needs. The software can cause the core (1840) and specifically the processors therein (including CPU, GPU, FPGA, and the like) to execute particular processes or particular parts of particular processes described herein, including defining data structures stored in RAM (1846) and modifying such data structures according to the processes defined by the software. In addition or as an alternative, the computer system can provide functionality as a result of logic hardwired or otherwise embodied in a circuit (for example: accelerator (1844)), which can operate in place of or together with software to execute particular processes or particular parts of particular processes described herein. Reference to software can encompass logic, and vice versa, where appropriate. Reference to a computer-readable media can encompass a circuit (such as an integrated circuit (IC)) storing software for execution, a circuit embodying logic for execution, or both, where appropriate. The present disclosure encompasses any suitable combination of hardware and software.

#### Appendix A: Acronyms

JEM: joint exploration model

VVC: versatile video coding

BMS: benchmark set

MV: Motion Vector

HEVC: High Efficiency Video Coding

SEI: Supplementary Enhancement Information

VUI: Video Usability Information

GOPs: Groups of Pictures

TUs: Transform Units,

PUs: Prediction Units

CTUs: Coding Tree Units

CTBs: Coding Tree Blocks

PBs: Prediction Blocks  
HRD: Hypothetical Reference Decoder  
SNR: Signal Noise Ratio  
CPUs: Central Processing Units  
GPUs: Graphics Processing Units  
CRT: Cathode Ray Tube  
LCD: Liquid-Crystal Display  
OLED: Organic Light-Emitting Diode  
CD: Compact Disc  
DVD: Digital Video Disc  
ROM: Read-Only Memory  
RAM: Random Access Memory  
ASIC: Application-Specific Integrated Circuit  
PLD: Programmable Logic Device  
LAN: Local Area Network  
GSM: Global System for Mobile communications  
LTE: Long-Term Evolution  
CANBus: Controller Area Network Bus  
USB: Universal Serial Bus  
PCI: Peripheral Component Interconnect  
FPGA: Field Programmable Gate Areas  
SSD: solid-state drive  
IC: Integrated Circuit  
CU: Coding Unit

**[0188]** While this disclosure has described several exemplary embodiments, there are alterations, permutations, and various substitute equivalents, which fall within the scope of the disclosure. It will thus be appreciated that those skilled in the art will be able to devise numerous systems and methods which, although not explicitly shown or described herein, embody the principles of the disclosure and are thus within the spirit and scope thereof.

**WHAT IS CLAIMED IS:**

1. A method of video decoding performed in a video decoder, the method comprising:
  - receiving coded information of a current block and neighboring samples of the current block from a coded video bitstream;
  - determining one or more intra mode predictors of the current block, wherein the one or more intra mode predictors are derived based on the neighboring samples of the current block via either a decoder side intra mode derivation (DIMD) or a template-based intra mode derivation (TIMD);
  - determining whether a position dependent intra prediction combination (PDPC) is to be applied based on the one or more intra mode predictors;
  - in response to the determining that the PDPC is to be applied, performing a fusion process on the one or more intra mode predictors, the fusion process combining the one or more intra mode predictors to generate a single intra mode predictor;
  - applying the PDPC based on the single intra mode predictor to generate a modified predictor of the current block subsequent to the fusion process on the one or more intra mode predictors; and
  - reconstructing the current block based on the modified predictor generated by the PDPC.
2. The method of claim 1, wherein:
  - the performing the fusion process includes generating the single intra mode predictor based on a weighted combination of the one or more intra mode predictors, and
  - the applying the PDPC further includes generating the modified predictor based on a weighted combination of (i) one or more neighboring samples of the neighboring samples and (ii) the single intra mode predictor.
3. The method of claim 1, wherein the determining the one or more intra mode predictors further comprises:
  - in response to the one or more intra mode predictors being derived based on the DIMD,
  - determining a first intra mode predictor of the one or more intra mode predictors based on a first intra mode, the first intra mode being determined based on the neighboring samples and associated with a highest histogram of gradient (HoG) of the neighboring samples;

determining a second intra mode predictor of the one or more intra mode predictors based on a second intra mode, the second intra mode being determined based on the neighboring samples and associated with a second highest HoG of the neighboring samples; and

determining a third intra mode predictor of the one or more intra mode predictors based on a planar mode.

4. The method of claim 3, wherein the determining whether the PDPC is to be applied further comprises:

determining whether the PDPC is applicable based on the first intra mode that is derived based on the DIMD.

5. The method of claim 3, wherein the determining whether the PDPC is to be applied further comprises:

in response to the first intra mode and the second intra mode being angular modes, determining whether the PDPC is applicable based on an average angular value of the first intra mode and the second intra mode; and

in response to one of the first intra mode and the second intra mode being an angular mode, determining whether the PDPC is applicable based on the one of the first intra mode and the second intra mode that is the angular mode.

6. The method of claim 1, wherein the determining whether the PDPC is to be applied further comprises:

determining that the PDPC is applicable in response to at least one of the one or more intra mode predictors being determined based on a planar mode or a DC mode.

7. The method of claim 1, wherein the determining the one or more intra mode predictors comprises:

in response to the one or more intra mode predictors being derived based on the TIMD,

determining a first intra mode predictor of the one or more intra mode predictors based on a first intra mode, the first intra mode being determined based on the neighboring samples and associated with a smallest cost value of the neighboring samples; and

determining a second intra mode predictor of the one or more intra mode predictors based on a second intra mode, the second intra mode being determined based on the neighboring samples and associated with a second smallest cost value of the neighboring samples.

8. The method of claim 7, wherein the determining whether the PDPC is to be applied further comprises:

determining whether the PDPC is applicable based on the first intra mode that is derived based on the TIMD.

9. The method of claim 7, wherein the determining whether the PDPC is to be applied further comprises:

in response to the first intra mode and the second intra mode being angular modes, determining whether the PDPC is applicable based on an average angular value of the first intra mode and the second intra mode; and

in response to one of the first intra mode and the second intra mode being an angular mode, determining whether the PDPC is applicable based on the one of the first intra mode and the second intra mode that is the angular mode.

10. The method of claim 7, wherein the determining whether the PDPC is to be applied further comprises:

determining that the PDPC is applicable in response to at least one of the first intra mode and the second intra mode being a planar mode or a DC mode.

11. An apparatus, comprising:

processing circuitry configured to:

receive coded information of a current block and neighboring samples of the current block from a coded video bitstream;

determine one or more intra mode predictors of the current block, wherein the one or more intra mode predictors are derived based on the neighboring samples of the current block via either a decoder side intra mode derivation (DIMD) or a template-based intra mode derivation (TIMD);

determine whether a position dependent intra prediction combination (PDPC) is to be applied based on the one or more intra mode predictors;

in response to the determining that the PDPC is to be applied, perform a fusion process on the one or more intra mode predictors, the fusion process combining the one or more intra mode predictors to generate a single intra mode predictor;

apply the PDPC based on the single intra mode predictor to generate a modified predictor of the current block subsequent to the fusion process on the one or more intra mode predictors; and

reconstruct the current block based on the modified predictor generated by the PDPC.

12. The apparatus of claim 11, wherein the processing circuitry is configured to: perform the fusion process to generate the single intra mode predictor based on a weighted combination of the one or more intra mode predictors, and

apply the PDPC to generate the modified predictor based on a weighted combination of (i) one or more neighboring samples of the neighboring samples and (ii) the single intra mode predictor.

13. The apparatus of claim 11, wherein the processing circuitry is configured to: in response to the one or more intra mode predictors being derived based on the DIMD, determine a first intra mode predictor of the one or more intra mode predictors based on a first intra mode, the first intra mode being determined based on the neighboring samples and associated with a highest histogram of gradient (HoG) of the neighboring samples;

determine a second intra mode predictor of the one or more intra mode predictors based on a second intra mode, the second intra mode being determined based on the neighboring samples and associated with a second highest HoG of the neighboring samples; and

determine a third intra mode predictor of the one or more intra mode predictors based on a planar mode.

14. The apparatus of claim 13, wherein the processing circuitry is configured to:

determine whether the PDPC is applicable based on the first intra mode that is derived based on the DIMD.

15. The apparatus of claim 13, wherein the processing circuitry is configured to:  
in response to the first intra mode and the second intra mode being angular modes, determine whether the PDPC is applicable based on an average angular value of the first intra mode and the second intra mode; and  
in response to one of the first intra mode and the second intra mode being an angular mode, determine whether the PDPC is applicable based on the one of the first intra mode and the second intra mode that is the angular mode.

16. The apparatus of claim 11, wherein the processing circuitry is configured to:  
determine that the PDPC is applicable in response to at least one of the one or more intra mode predictors being determined based on a planar mode or a DC mode.

17. The apparatus of claim 11, wherein the processing circuitry is configured to:  
in response to the one or more intra mode predictors being derived based on the TIMD,  
determine a first intra mode predictor of the one or more intra mode predictors based on a first intra mode, the first intra mode being determined based on the neighboring samples and associated with a smallest cost value of the neighboring samples; and  
determine a second intra mode predictor of the one or more intra mode predictors based on a second intra mode, the second intra mode being determined based on the neighboring samples and associated with a second smallest cost value of the neighboring samples.

18. The apparatus of claim 17, wherein the processing circuitry is configured to:  
determine whether the PDPC is applicable based on the first intra mode that is derived based on the TIMD.

19. The apparatus of claim 17, wherein the processing circuitry is configured to:

in response to the first intra mode and the second intra mode being angular modes, determine whether the PDPC is applicable based on an average angular value of the first intra mode and the second intra mode; and

in response to one of the first intra mode and the second intra mode being an angular mode, determine whether the PDPC is applicable based on the one of the first intra mode and the second intra mode that is the angular mode.

20. The apparatus of claim 17, wherein the processing circuitry is configured to:

determine that the PDPC is applicable in response to at least one of the first intra mode and the second intra mode being a planar mode or a DC mode.

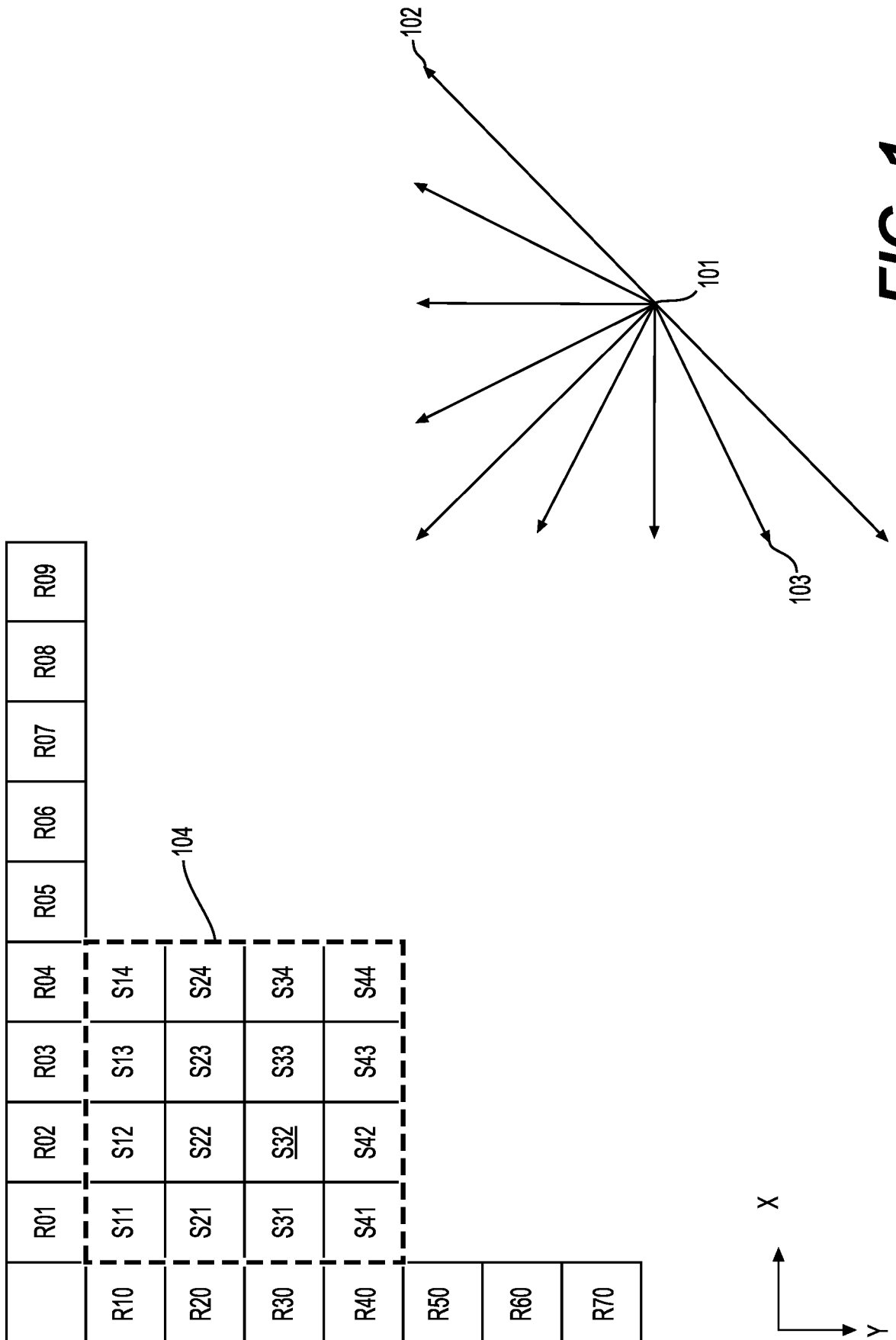
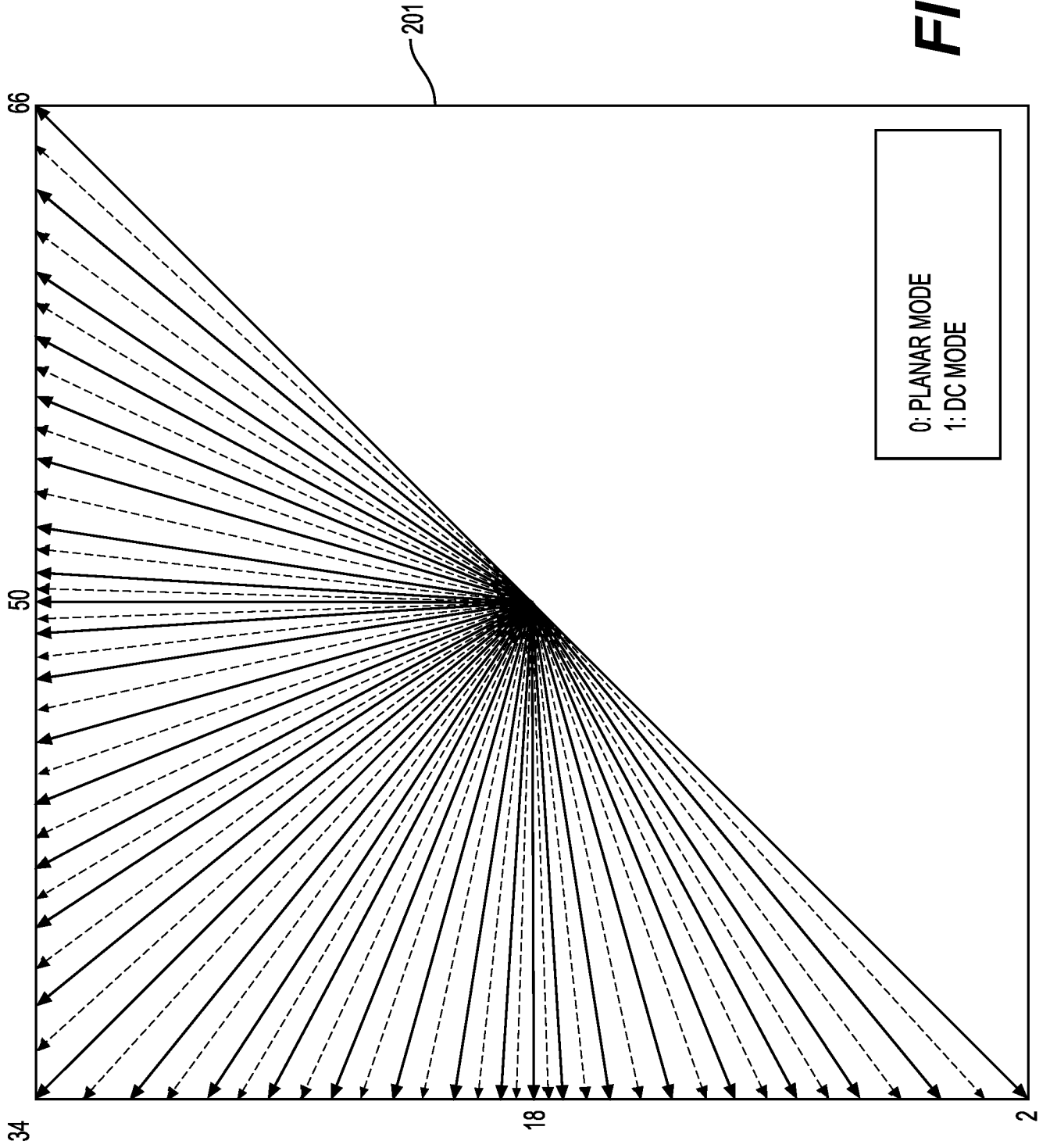
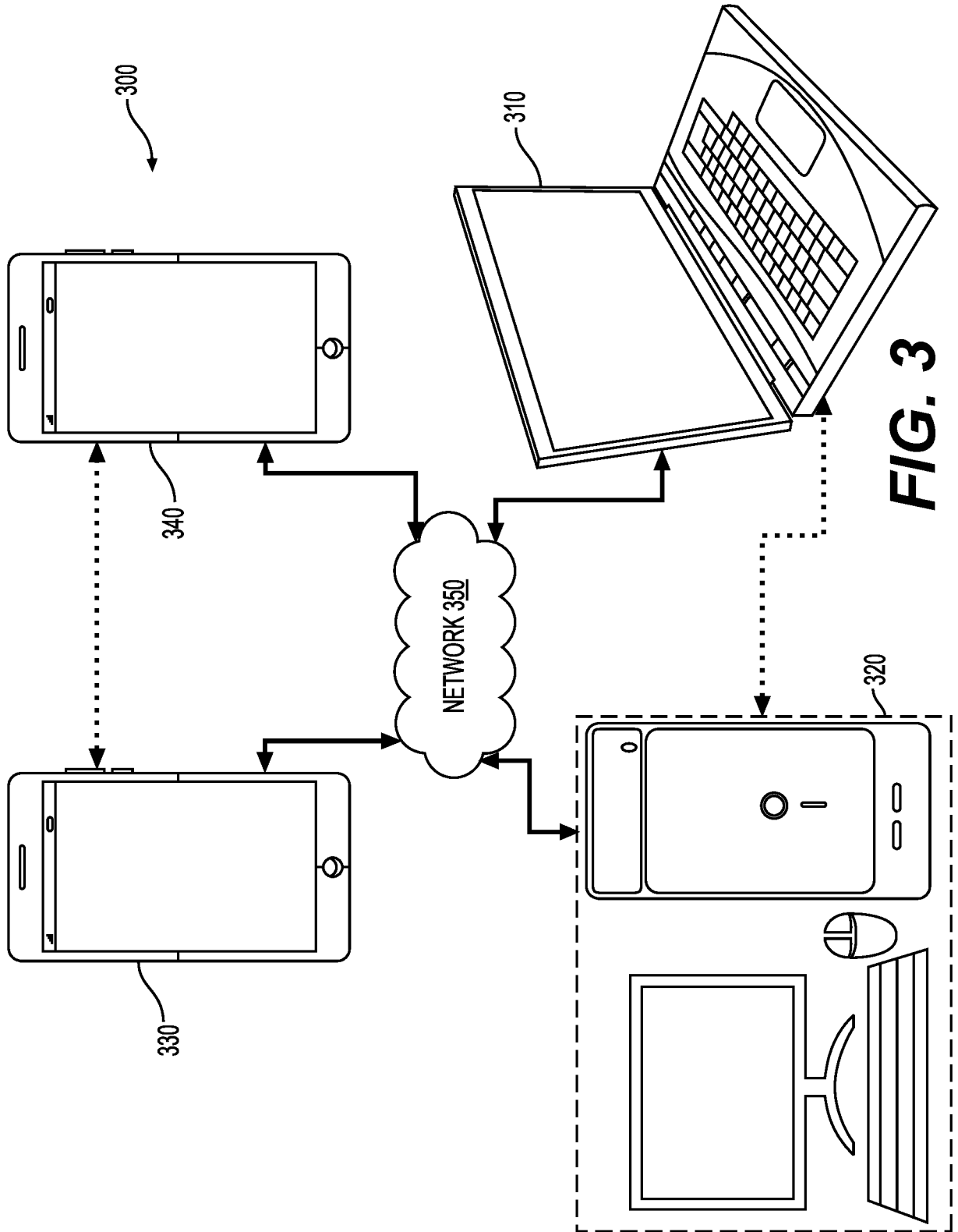

FIG. 1



**FIG. 2**



**FIG. 3**

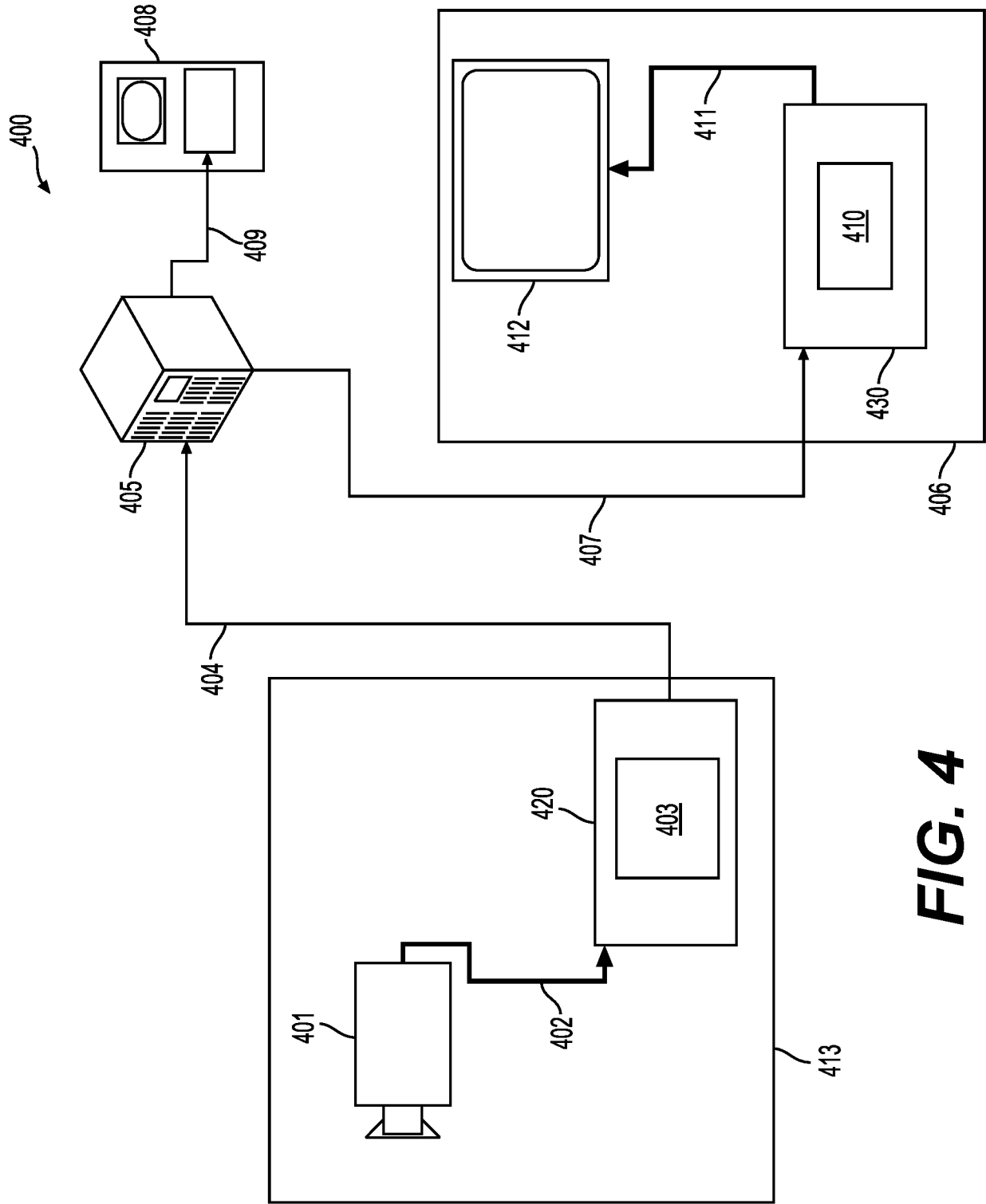

**FIG. 4**

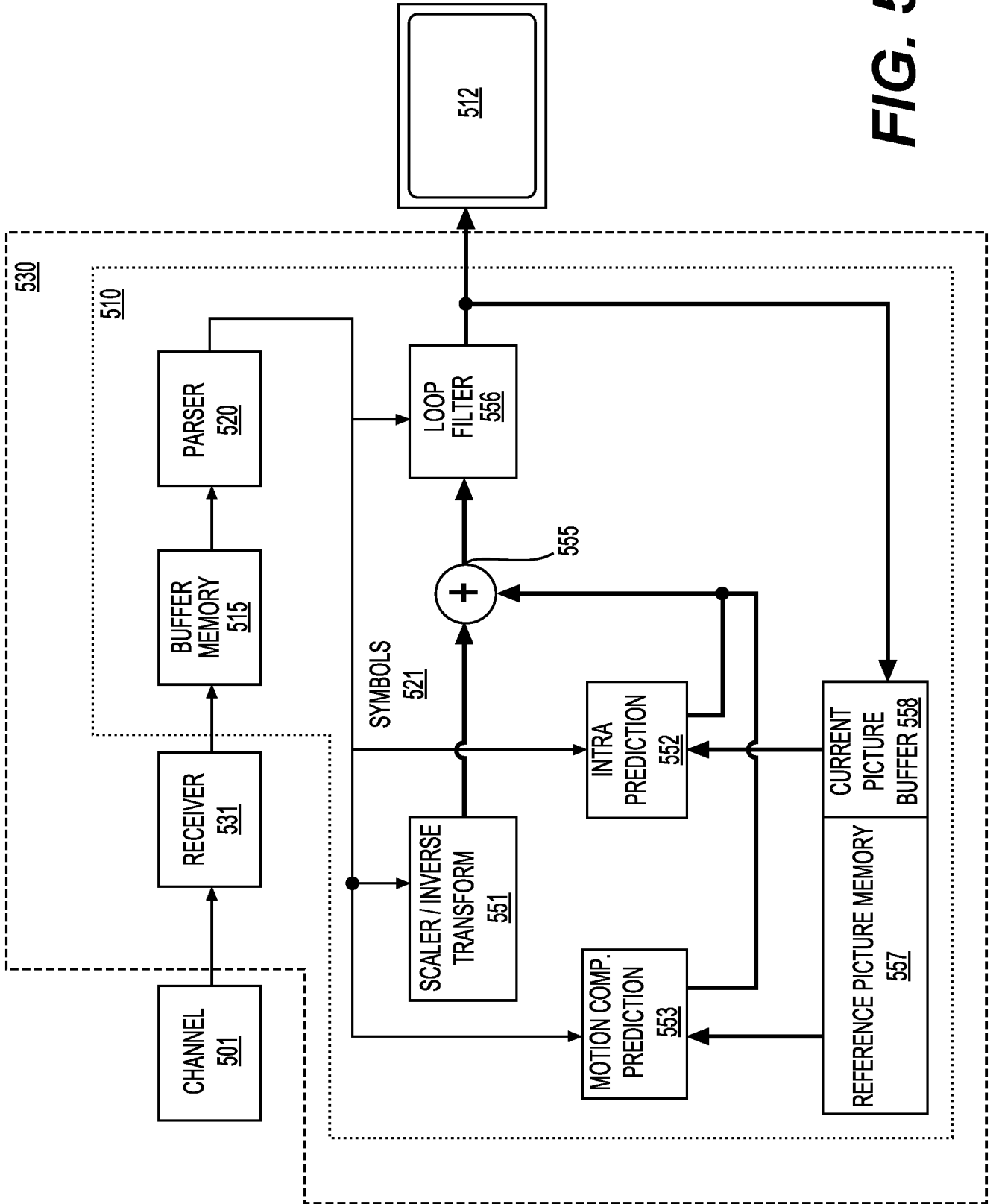
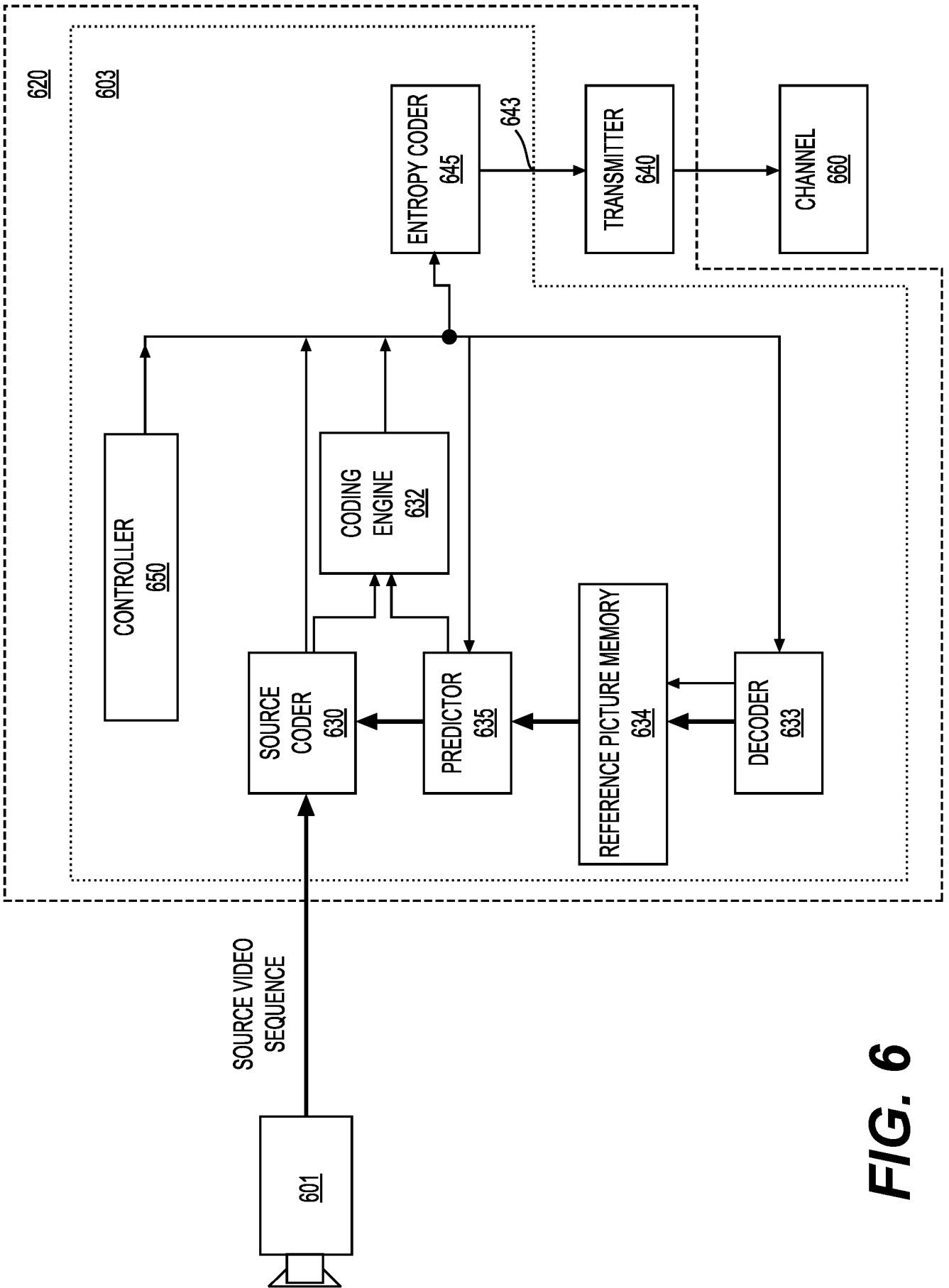
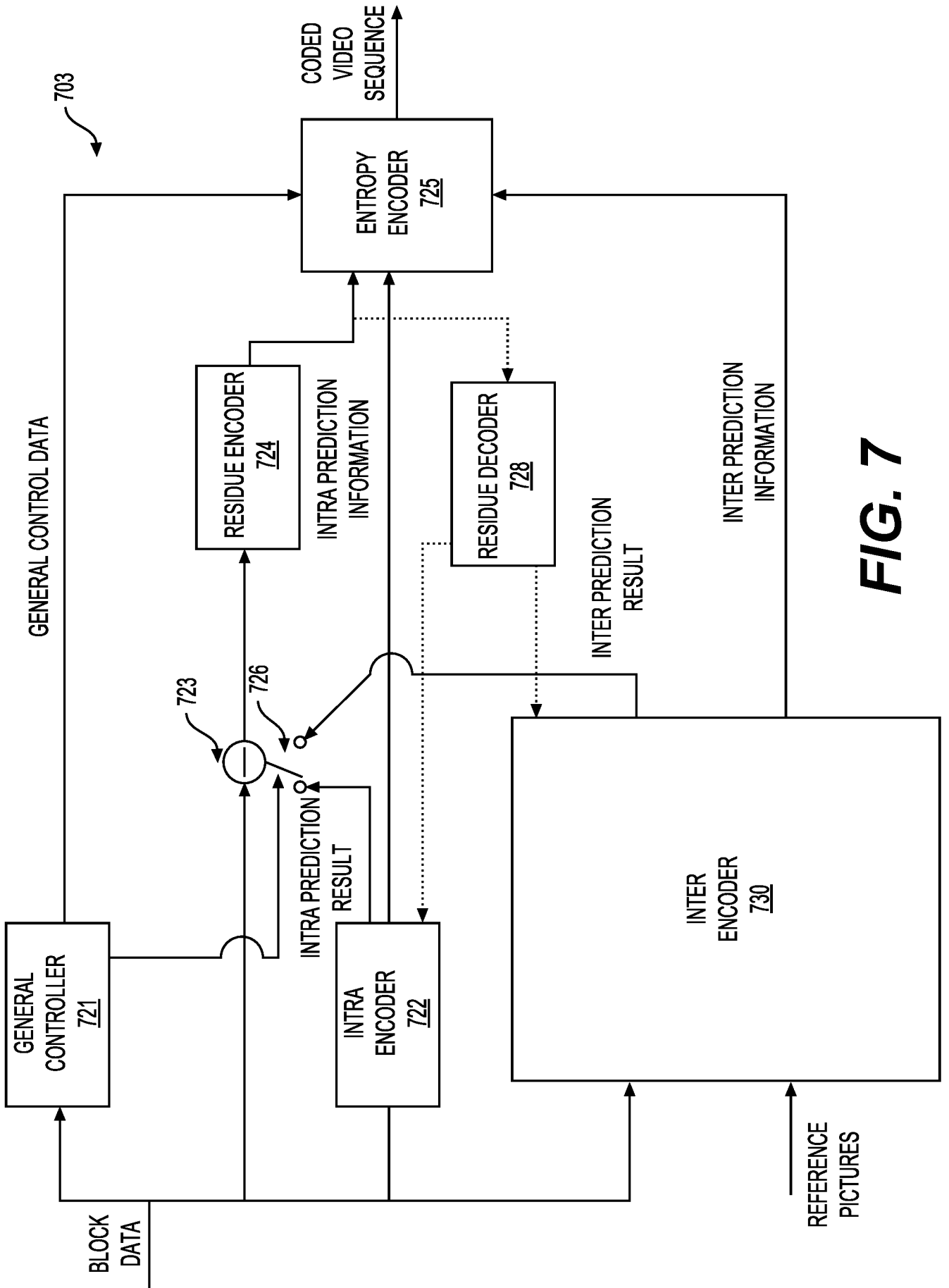

FIG. 5



**FIG. 6**



**FIG. 7**

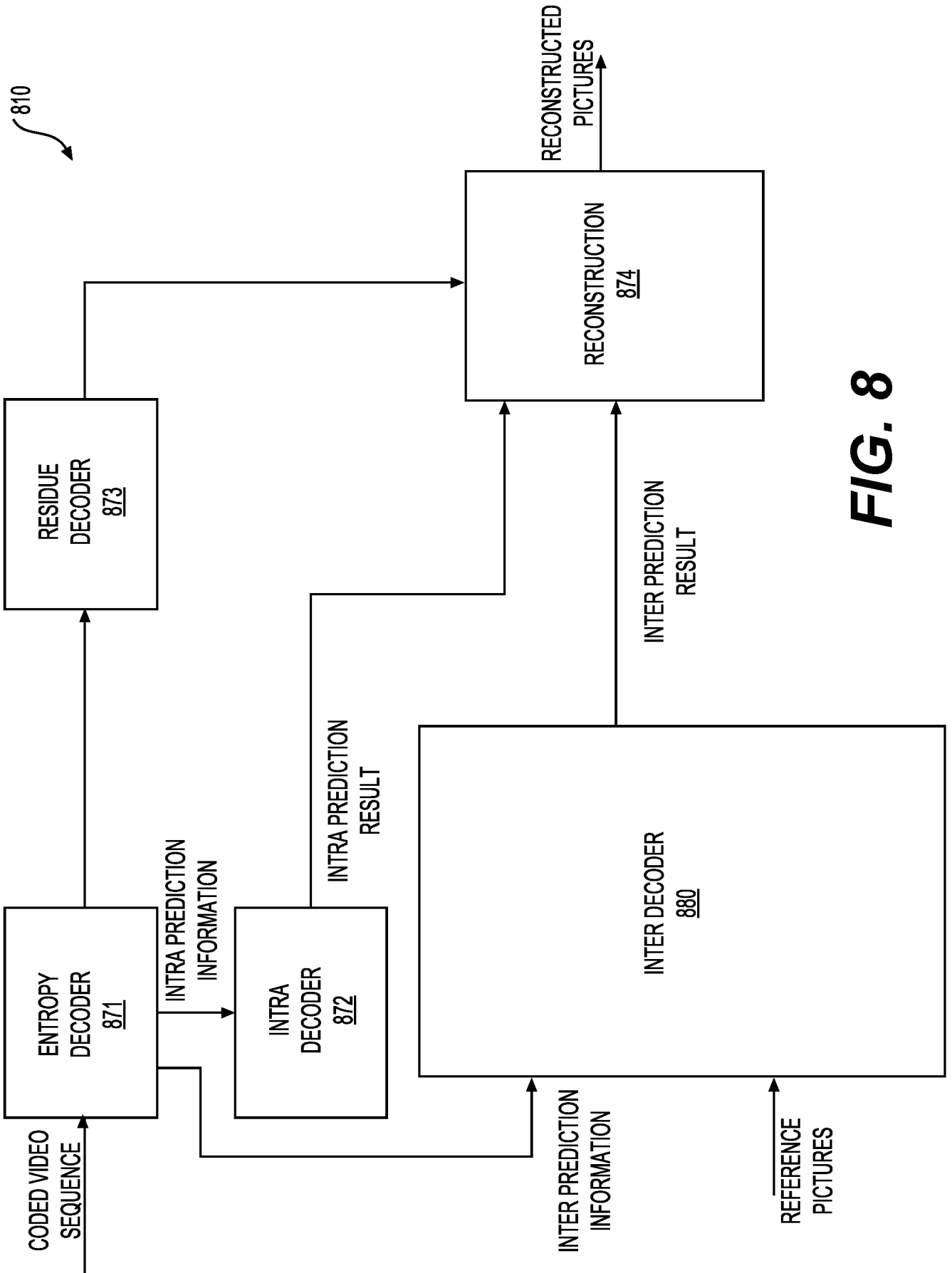
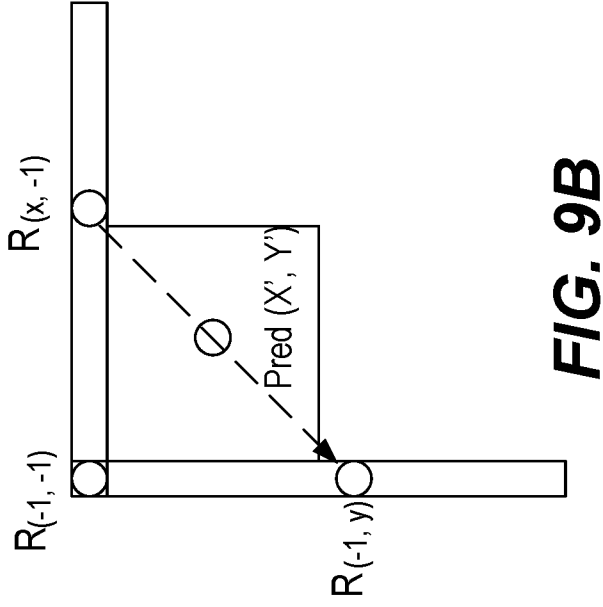
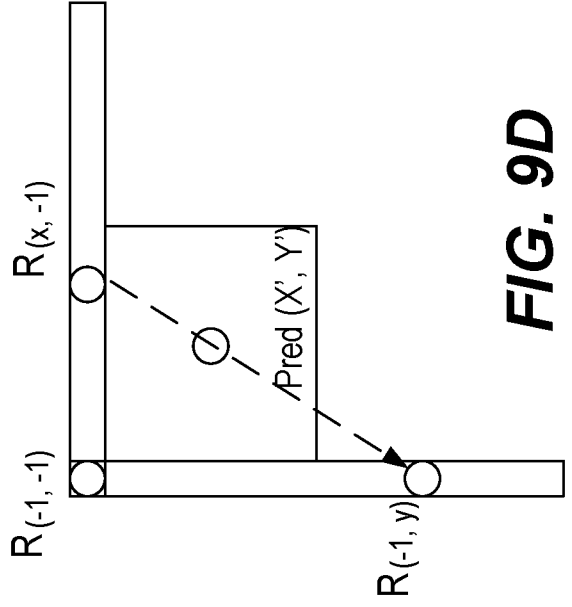

FIG. 8



**FIG. 9A**



**FIG. 9B**

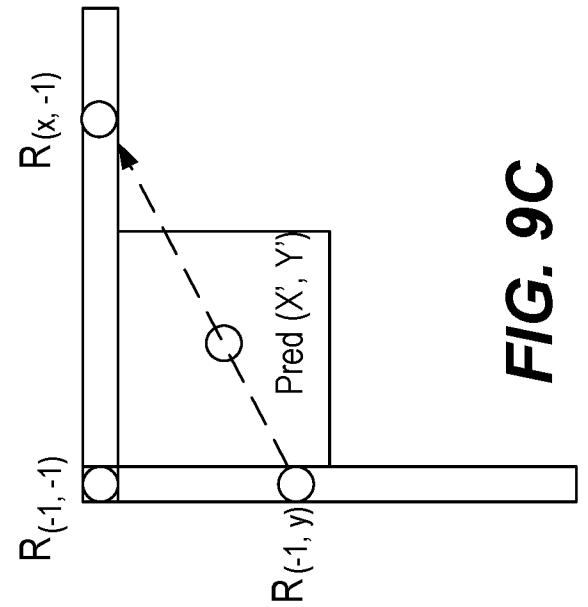

**FIG. 9C**

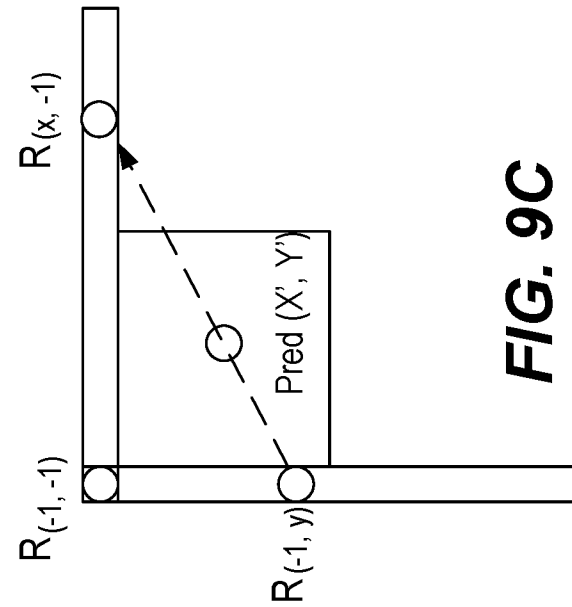

**FIG. 9D**

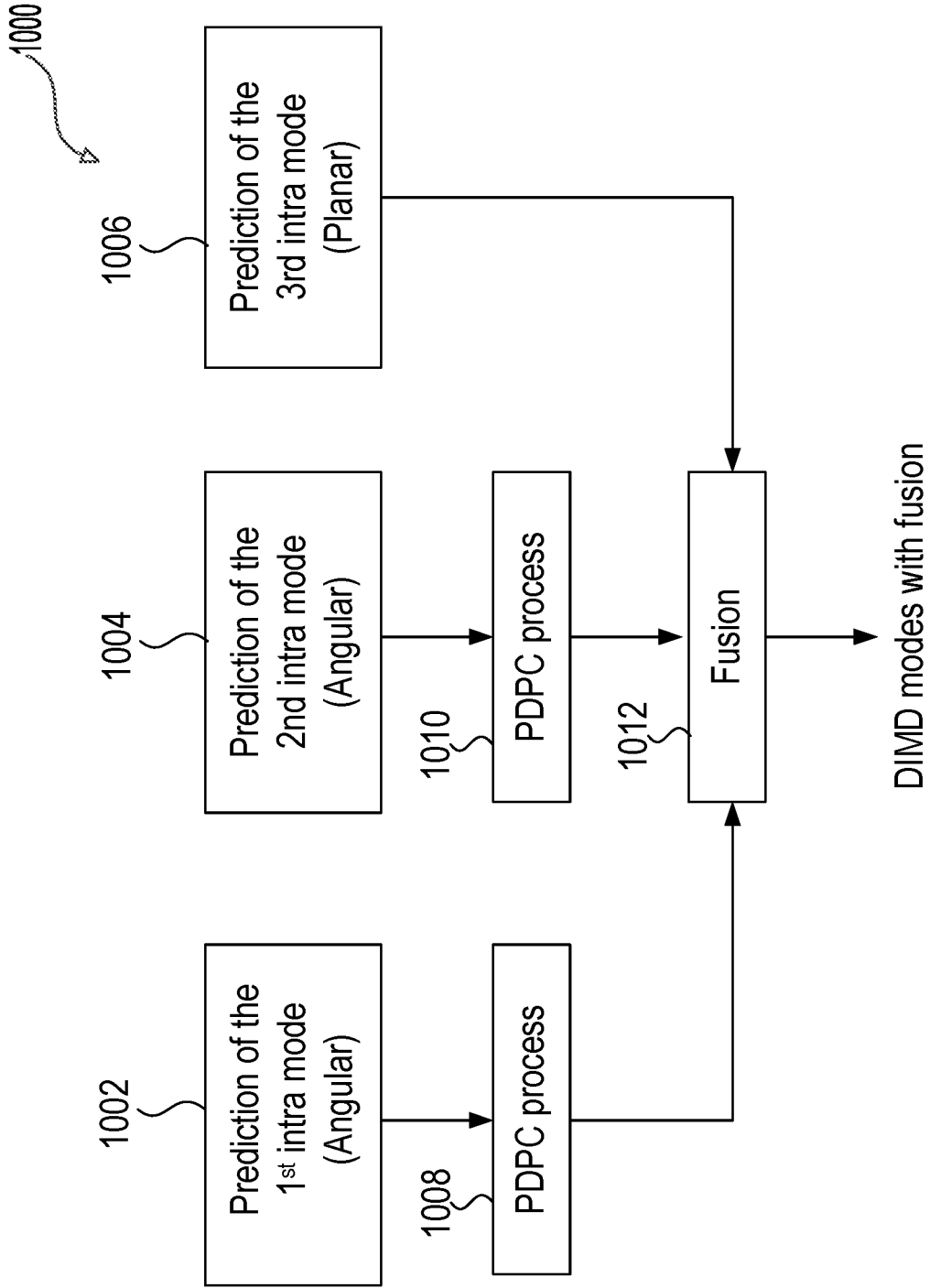

**FIG. 10**

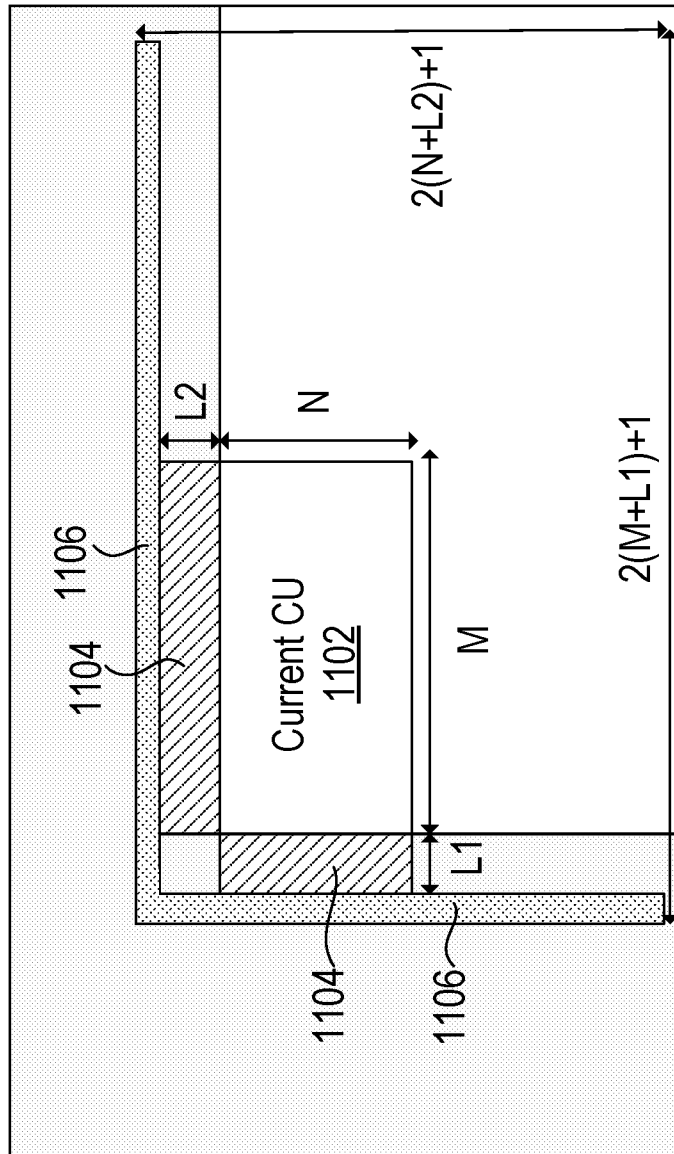

**FIG. 11**

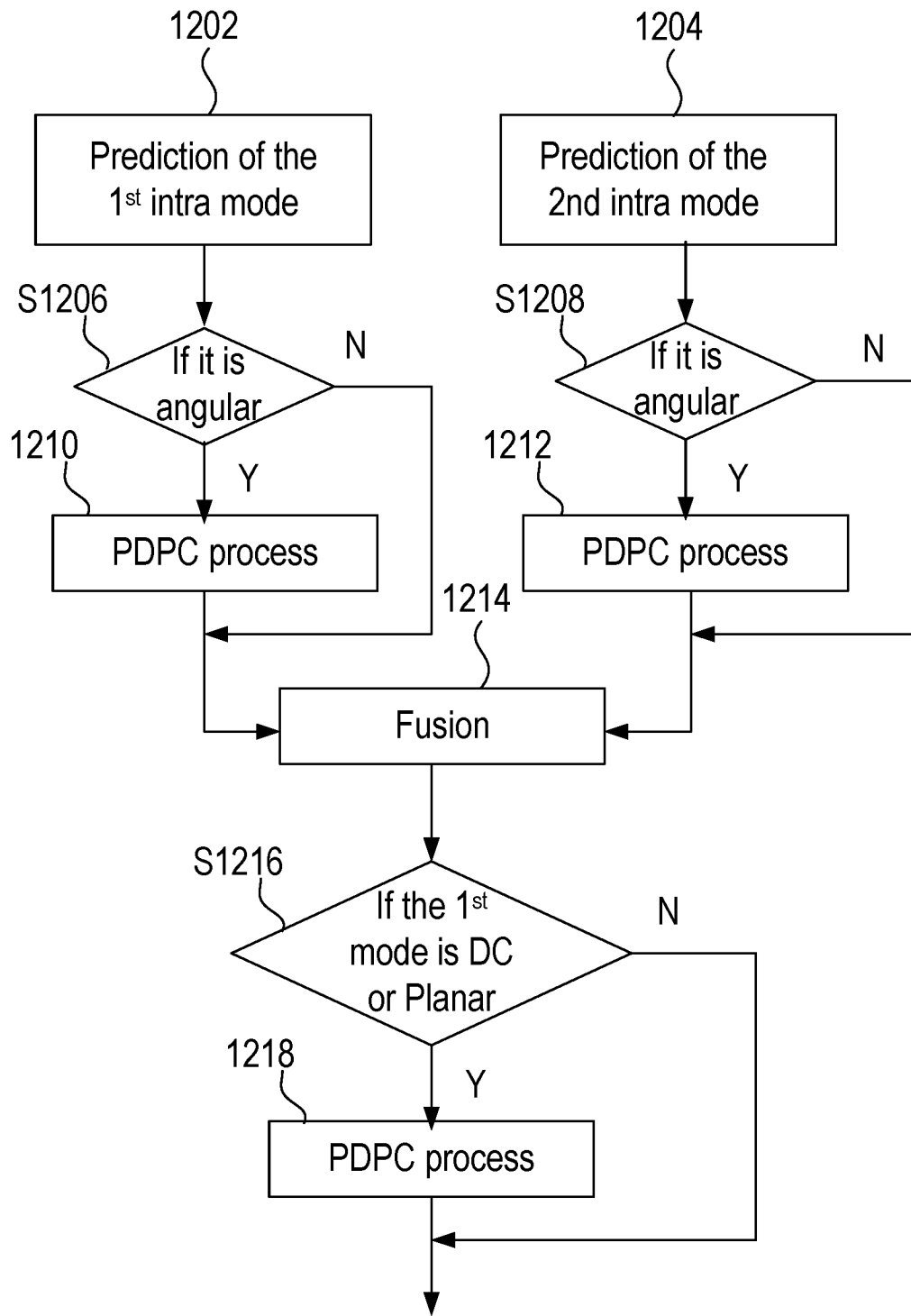

**FIG. 12**

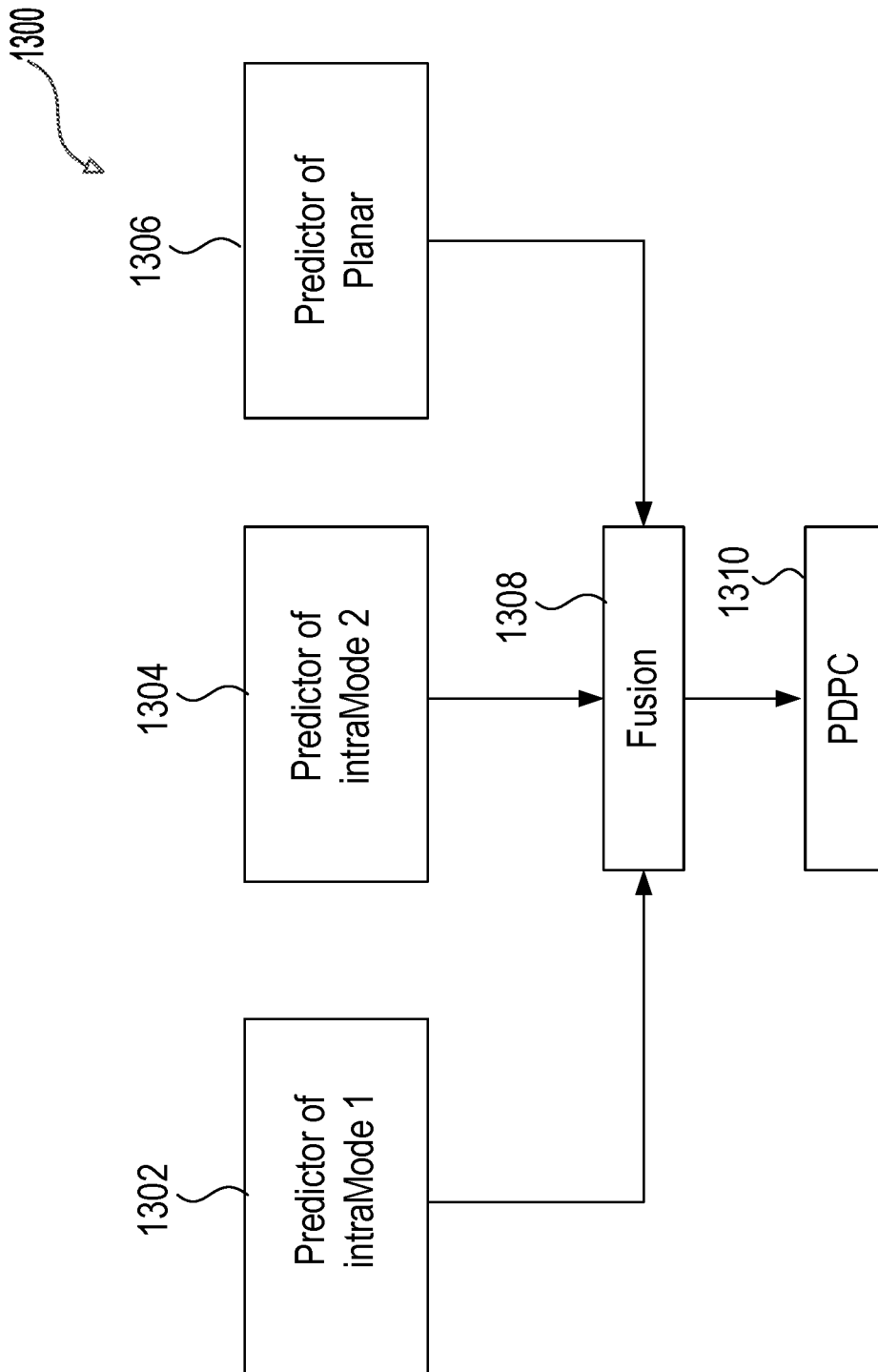

**FIG. 13**

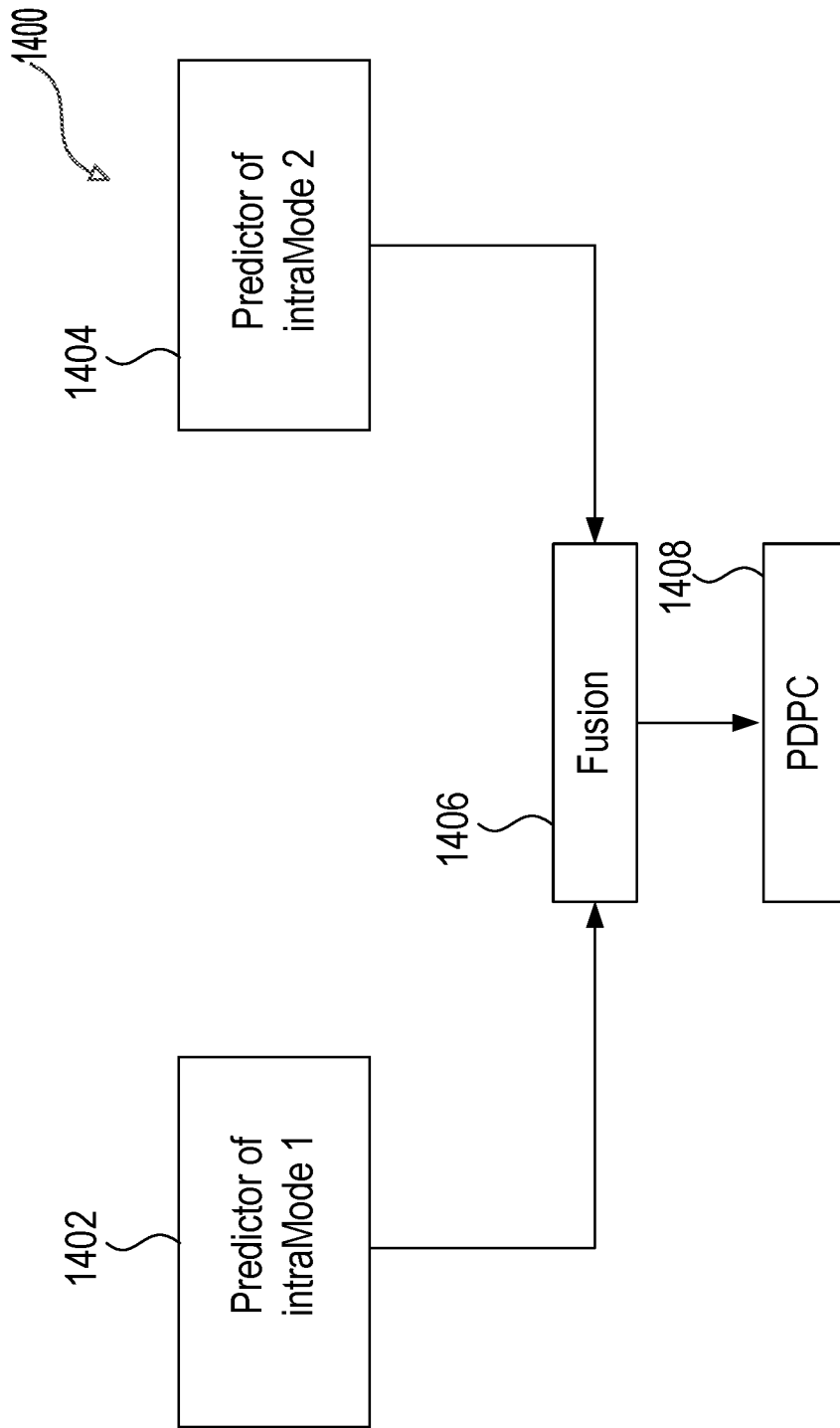

**FIG. 14**

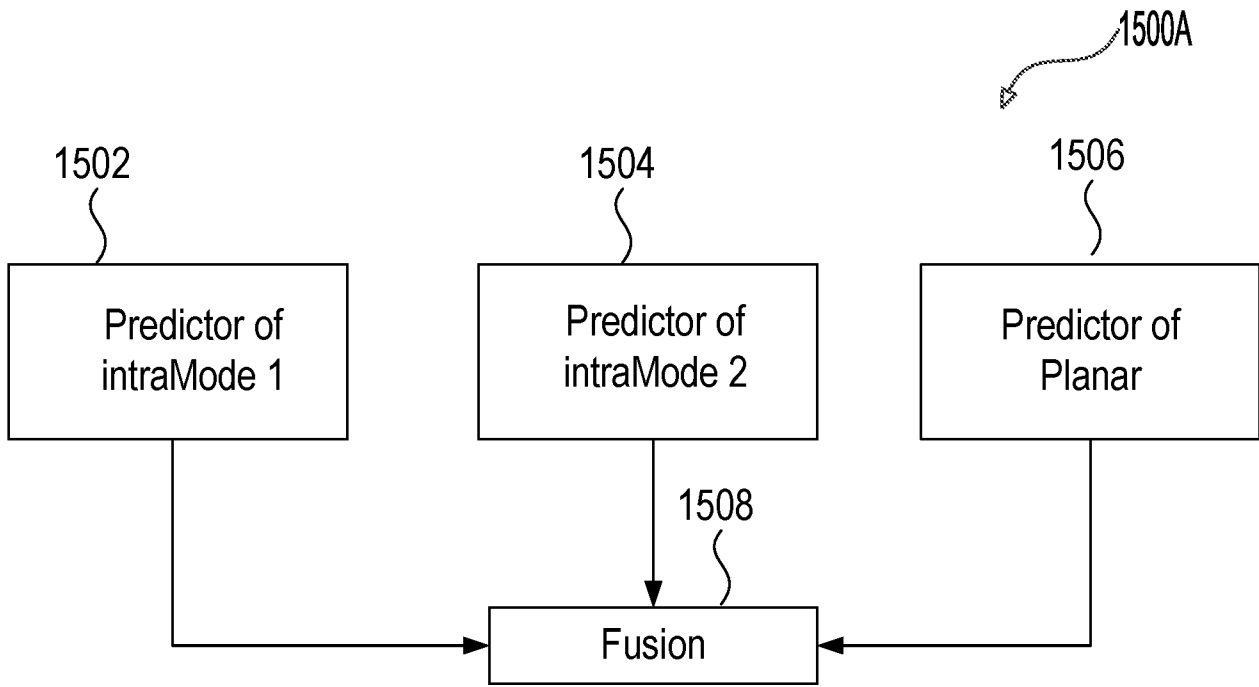

**FIG. 15A**

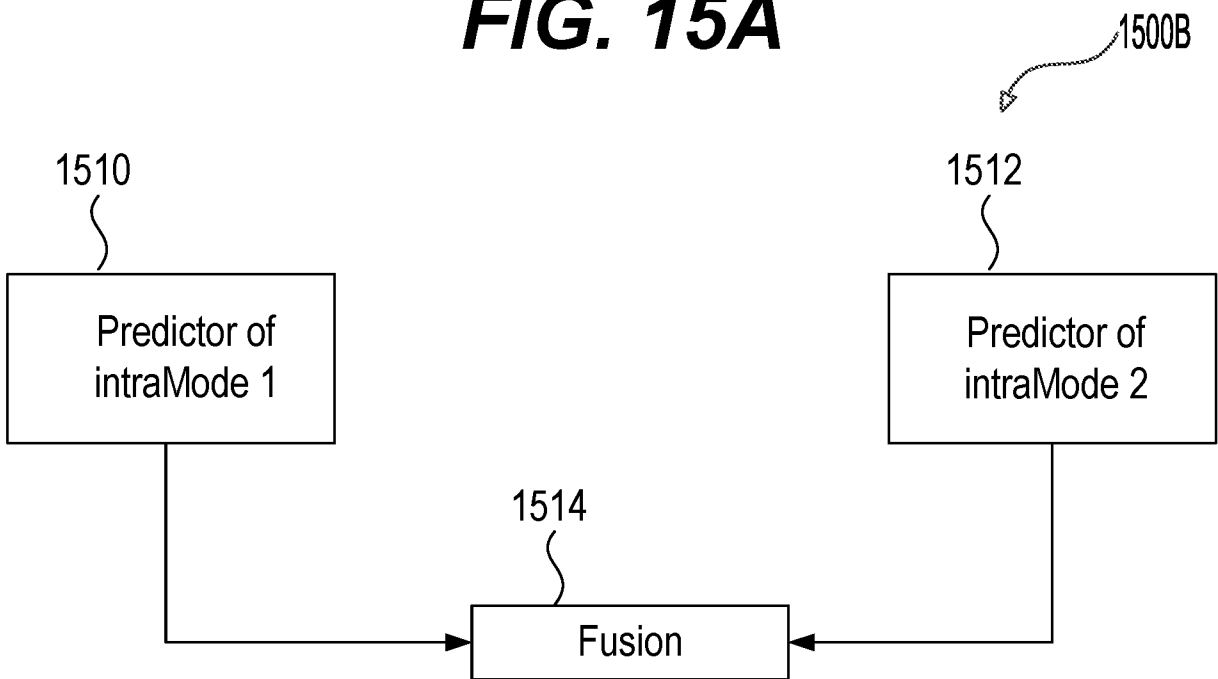

**FIG. 15B**

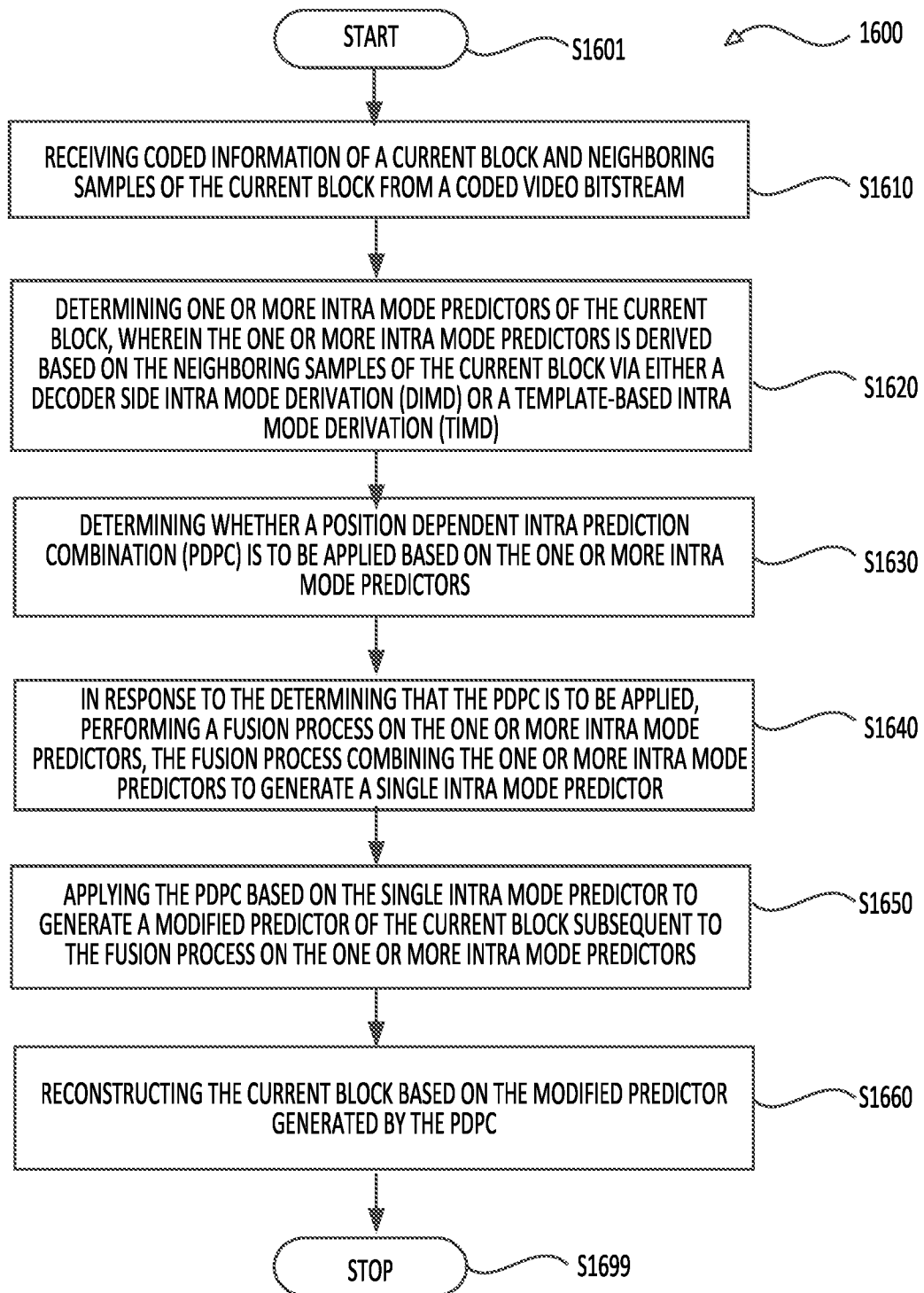

**FIG. 16**

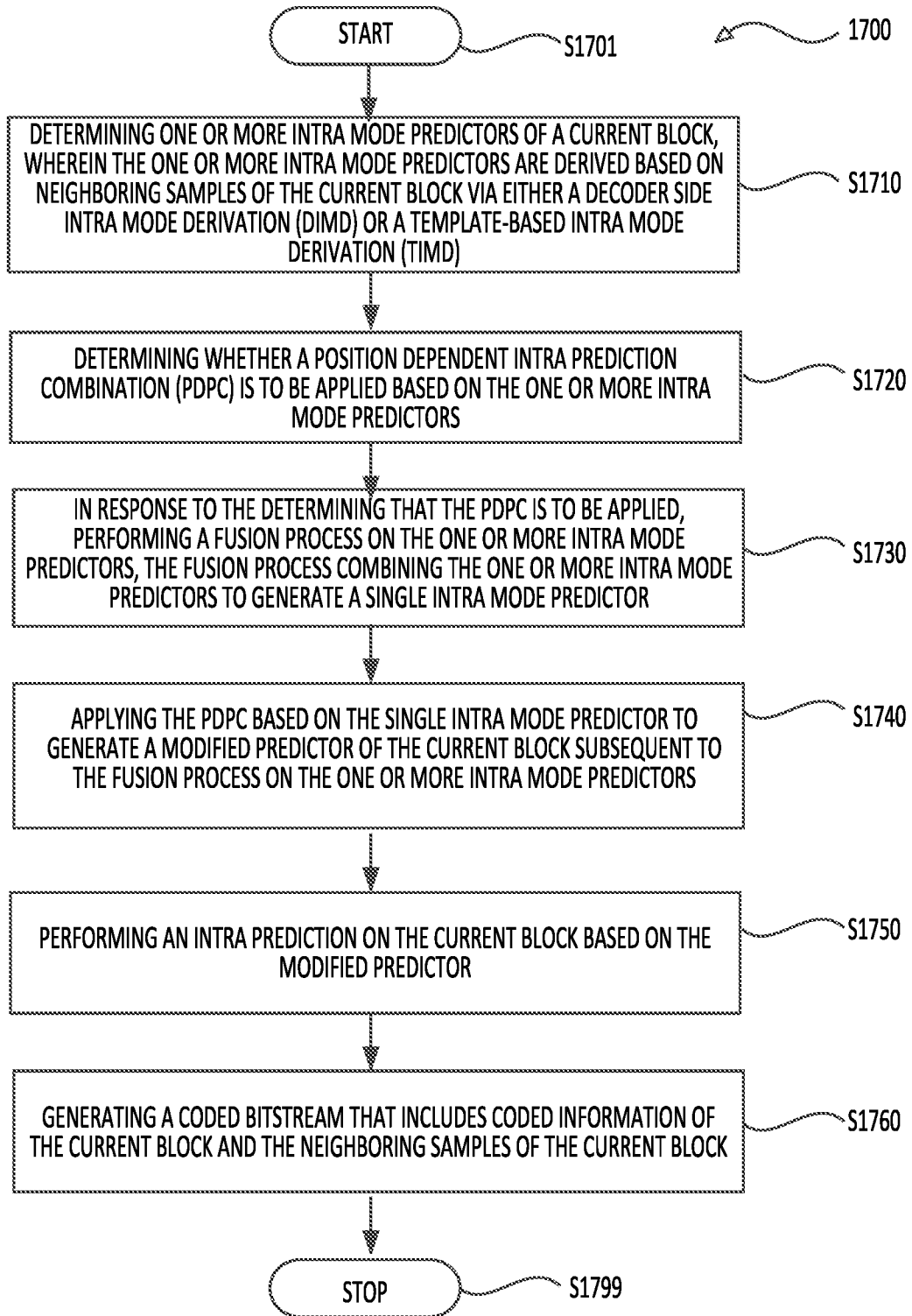

**FIG. 17**

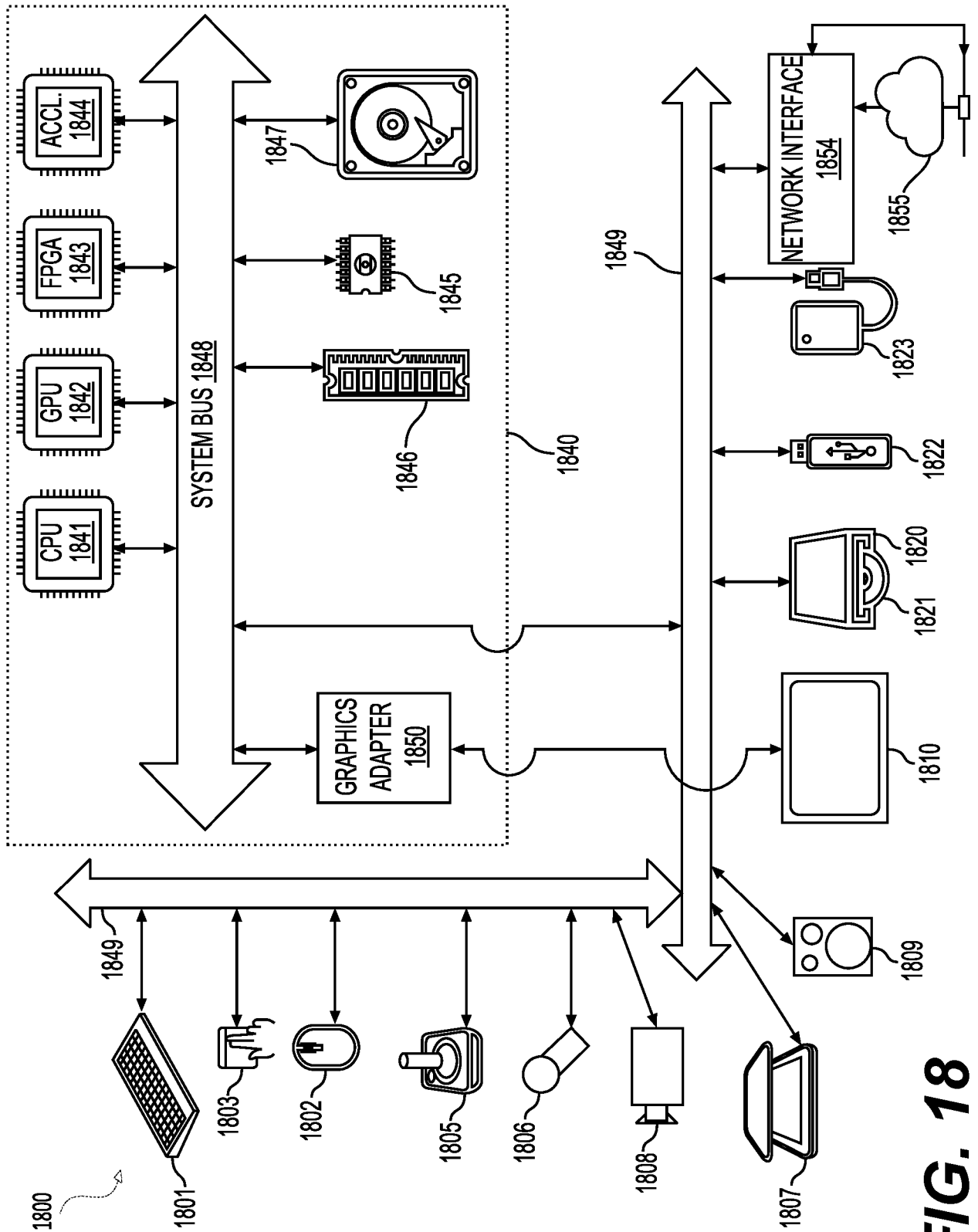

**FIG. 18**

## INTERNATIONAL SEARCH REPORT

International application No.

PCT/US 22/76408

## A. CLASSIFICATION OF SUBJECT MATTER

IPC - INV. H04N 19/103 (2022.01)

ADD.

CPC - INV. H04N 19/103, H04N 19/11, H04N 19/147, H04N 19/176

ADD.

According to International Patent Classification (IPC) or to both national classification and IPC

## B. FIELDS SEARCHED

Minimum documentation searched (classification system followed by classification symbols)

See Search History document

Documentation searched other than minimum documentation to the extent that such documents are included in the fields searched

See Search History document

Electronic data base consulted during the international search (name of data base and, where practicable, search terms used)

See Search History document

## C. DOCUMENTS CONSIDERED TO BE RELEVANT

Category*	Citation of document, with indication, where appropriate, of the relevant passages	Relevant to claim No.
Y	US 2019/0166370 A1 (Vid Scale, Inc), 30 May 2019 (30.05.2019), entire document	1-20
Y	US 2020/0396470 A1 (Tencent America LLC), 17 December 2020 (17.12.2020), entire document	1-20
Y	Abdoli et al. "JVET-N0342: Decoder-side Intra Mode Derivation with Prediction Fusion." In: Preprint, May 2019, [online] [retrieved on 09 November 2022 (09.11.2022)] Retrieved from the Internet < URL: <a href="https://www.researchgate.net/publication/332865710">https://www.researchgate.net/publication/332865710</a> >, entire document	1-20
A	US 2017/0272759 A1 (Qualcomm Inc), 21 September 2017 (21.09.2017), entire document	1-20

 Further documents are listed in the continuation of Box C. See patent family annex.

\* Special categories of cited documents:

"A" document defining the general state of the art which is not considered to be of particular relevance

"D" document cited by the applicant in the international application

"E" earlier application or patent but published on or after the international filing date

"L" document which may throw doubts on priority claim(s) or which is cited to establish the publication date of another citation or other special reason (as specified)

"O" document referring to an oral disclosure, use, exhibition or other means

"P" document published prior to the international filing date but later than the priority date claimed

"T" later document published after the international filing date or priority date and not in conflict with the application but cited to understand the principle or theory underlying the invention

"X" document of particular relevance; the claimed invention cannot be considered novel or cannot be considered to involve an inventive step when the document is taken alone

"Y" document of particular relevance; the claimed invention cannot be considered to involve an inventive step when the document is combined with one or more other such documents, such combination being obvious to a person skilled in the art

"&amp;" document member of the same patent family

Date of the actual completion of the international search

10 November 2022

Date of mailing of the international search report

DEC 13 2022

Name and mailing address of the ISA/US

Mail Stop PCT, Attn: ISA/US, Commissioner for Patents

P.O. Box 1450, Alexandria, Virginia 22313-1450

Facsimile No. 571-273-8300

Authorized officer

Kari Rodriguez

Telephone No. PCT Helpdesk: 571-272-4300