

(19)



Europäisches Patentamt
European Patent Office
Office européen des brevets



(11)

EP 0 860 140 A2

(12)

EUROPEAN PATENT APPLICATION

(43) Date of publication:
26.08.1998 Bulletin 1998/35

(51) Int Cl.6: A47L 15/42

(21) Application number: 98830071.1

(22) Date of filing: 16.02.1998

(84) Designated Contracting States:
AT BE CH DE DK ES FI FR GB GR IE IT LI LU MC
NL PT
Designated Extension States:
AL LT LV MK RO SI

(71) Applicant: T & P S.p.A.
21049 Tradate (Varese) (IT)

(72) Inventor: Carli, Carlo
21100 Varese (IT)

(30) Priority: 18.02.1997 IT TO970135

(74) Representative: Dini, Roberto, Dr. Ing.
Via Castagnole, 59
10060 None (Torino) (IT)

(54) Water softening system in a dishwashing machine

(57) A water softening system in a dishwashing machine of the type comprising a decalcifier device of water from the mains, containing decalcifying resins, a salt container to produce a saline solution for regenerating the resins contained in the decalcifier device, a container for the metering of regeneration water having a plurality of tanks to supply volumetrically defined amounts of water to the salt container, for producing the regenerating saline solution, said tanks, which are so ar-

ranged to be filled up in parallel, being of the air trap type and having upper vents, whose opening determines the filling of said tanks. According to the invention, a selector (8) is provided, being integral with the container (1), which can take a plurality of working positions (V1,V2,V3,V4,V5), each one of said working positions (V1,V2,V3,V4,V5) corresponding to the opening of a different combination of vents (S1,S2,S3,S4) of the tanks (R1,R2,R3,R4).

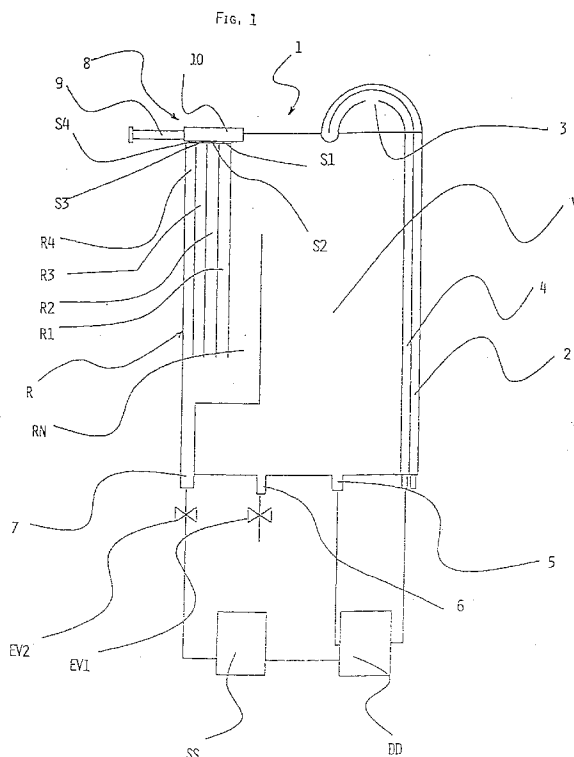

EP 0 860 140 A2

Description

The present invention refers to a water softening system in a dishwashing machine of the type comprising a decalcifier device of mains water containing decalcifying resins, a salt container for producing a brine solution to regenerate the resins contained in the decalcifier device, a container for the metering of regeneration water having a plurality of tanks to for supplying volumetrically defined amounts of water to the salt container to produce the regenerating brine solution, said tanks, which are so arranged to be filled up in parallel, being of the air-trap kind and fitted with upper vents, whose opening determines the filling of said tanks.

It is known that washing machines are equipped with systems for softening the water from the mains, which often contains a big quantity of limestone notoriously harmful for a good operation of the washing machine. Therefore, water from the mains is conveniently decalcified letting it flow first through a decalcifier device containing resins, which through a ionic exchange fix the calcium salts contained in the water and produce a low hardness water to be used without any difficulties by the washing machine.

Resins contained in the decalcifier device need to be reactivated, at given intervals, to remove calcium and magnesium that have accumulated. To this purpose, a tank is provided to be filled by the user with a proper salt, wherein with the addition of a proper water volume a saline solution, also called brine, is produced. Said brine flows over the resins and removes the accumulated calcium through a chemical reaction.

It is most useful to be able to establish the water volume needed for regeneration purposes according to the hardness degree of the water from the mains. As a matter of fact, water hardness may change significantly according to the place where the washing machine is installed and also with time. The water volume to be used for resin regeneration may then be higher or lower, according to a higher or lower hardness degree of the water from the mains.

Therefore, in order to change the water volume accordingly for regeneration, it is known to provide a plurality of tanks in parallel, configured as air traps, i.e. they are hollow columns having an upper vent. Water enters them under a certain pressure and rises along the column expelling the air through the vent. If the vent is plugged, the air cannot be expelled and consequently water will not enter the column.

Thus, the water volume to be stored and then be used for resin regeneration can be established through the opening and closing of said vents.

Said vents are opened and closed by acting on a plurality of small pipes coming out of said vents. Said pipes are usually connected with a rotary selector located outside the container, normally at a considerable distance from it (i.e. pipes must be adequately long) and can be progressively opened to connect the various

chambers with the environment outside.

This adjustment is usually performed by the installer of the washing machine, after evaluating the hardness of the mains water, and will be eventually repeated if any changes occur to the hardness of the water from the mains.

This control procedure has some drawbacks for its manufacturing complexity, due to the presence of small pipes and a separate selector. Moreover, said pipes may come off and cause a difficult in assembly, specifically if they are more than one or two.

It is the object of the present invention to solve the above drawbacks and provide an improved water softening system in a dishwashing machine, which is more reliable and cost-effective with respect to the solutions already known.

In this frame, it is the main object of the present invention to provide a water softening system in a dishwashing machine wherein the water volume to be used for the resins regeneration in the decalcifier device can be adjusted depending upon to the water hardness in a simple manner, and with an easy access.

It is a further object of the present invention to provide a water softening system in a dishwashing machine being of simple manufacturing and having a limited number of parts.

It is a further object of the present invention to provide a water softening system in a dishwashing machine, which is fully flexible for the choice of the water volumes to be used for the regeneration of the resins contained in the decalcifier device, and also having adequate reliability.

Said purposes are accomplished according to the present invention by a water softening system in a dishwashing machine having the features contained in the annexed claims, which form an integral part of the present description.

Further characteristics and advantages of the present invention will become more apparent from the following detailed description and annexed drawings, which are only supplied by way of a non limiting example, wherein:

- Fig. 1 shows a general outline of the device according to the present invention;
- Fig. 2 shows a section of a first component of the device represented in Fig. 1;
- Fig. 2a shows a section according to the axis P of the component represented in Fig. 2;
- Fig. 2b shows a section according to the axis Q of the component represented in Fig. 2;
- Fig. 3 shows a section of a second component of the device represented in Fig. 1;
- Fig. 3a shows a side view of the component represented in Fig. 3;
- Fig. 3b shows a section according to the axis G of the component represented in Fig. 3;
- Fig. 3c shows a section according to the axis H of

the component represented in Fig. 3;

- Figs. 3d, 3e, 3f and 3g show four sections according to the axis K, L, M, N, respectively, of the component represented in Fig. 3.

In Fig. 1 a tank 1 is represented, of the type used for metering the water to be delivered to a washing tub, not represented here. Said tank 1 is manufactured by moulding a plastic material. Water is supplied from the mains through an inlet pipe 2, flows through an air breaker 3 and reaches a decalcifier device DD through a pipe 4. Water from the decalcifier device DD is returned to the tank 1 through a pipe 5. The water contained in the tank 1 can then be discharged into the tub through a pipe 6, by actuation of a proper solenoid valve EVI. Inside the tank 1 a compartment V contains the water to be introduced into the tub and a compartment R, which is apt to contain the water for regenerating the resins of the decalcifier device DD.

The compartment R has an outlet 7 connecting it with a salt container SS once the actuation of a solenoid valve EV2 has occurred. The compartment R is divided in a section RN, wherein the water overflowing the compartment V is collected, and other four columns R1, R2, R3, R4. Said columns R1, R2, R3, R4 are each provided with a vent, S1, S2, S3, S4 respectively. A selector 8 operates on said vents S1, S2, S3, S4, which is integral with them. The selector 8 consists of a selection rod 9 and a seal cylinder 10.

Thus, the compartment R can be filled with the water overflowing the compartment V after its filling. Thus, the section RN of compartment R will always be filled, whereas columns R1, R2, R3, R4 are only filled if their relevant vents S1, S2, S3 or S4 are opened by the selector 8. The outlet 7 allows discharge of both the section R and columns R1, R2, R3 and R4, should they be full of water.

In Fig. 2 the seal cylinder 10 is represented. Said seal cylinder 10 is made of plastic material during the moulding process of the tank 1 and communicates with columns R1, R2, R3, R4 through vents S1, S2, S3, S4. The seal cylinder 10 has an inlet opening 11 and an outlet opening 12. Near the inlet opening 11 some grooves 15 are provided, of which only the upper one can be seen in Fig. 2. The function of grooves 15 will be described in the following. In Fig. 2a a section according to the axis Q is represented, where the column R3 is shown with its relevant vent S3, that puts column R3 in communication with the inside of the seal cylinder 10.

In Fig. 2b a section according to the axis P is represents, showing the inlet opening 11 wherein the grooves 15 are obtained, which are spaced at substantially regular distances.

In Fig. 3 the selection rod 9 is represented, being inserted in the seal cylinder 10. Said selection rod 9 consists of a shaft 16, having a head 17, which ends on the opposite side with two engaging teeth 18. The shaft 16 is hollow and has an internal conduit 23, that ends be-

tween the engaging teeth 18; moreover, its central portion is contained inside a resilient cylinder 19. Four passages P1, P2, P3, P4, leading to the conduit 23, are defined both through the shaft 16 and the surrounding resilient cylinder 19. The shaft 16 is made of hard plastic material, whereas the resilient cylinder 19 is obtained by a co-moulding process of an elastomeric material.

In Fig. 3a the head 17 of the shaft 16 is shown, which has a seat 20 for allowing the shaft 16 to be rotated, for example through a screwdriver. References V1, V2, V3, V4 e V5 for the position of selector 8 are also indicated, corresponding substantially to the positions of the grooves 15 on the inlet opening 11.

Fig. 3b represents a section according to the axis G of the shaft 16, showing an indentation 22, which is jointly used with grooves 15 to obtain reference trips corresponding to the references. Thus, the joint action of indentation 22 surely selecting one of the possible positions defined by grooves 15 and references V1, V2, V3, V4, V5, will let the user to safely select the resins regeneration degree he wants to set.

In Fig. 3c a section is represented according to the axis H, showing how the resilient cylinder 19 is assembled around the shaft 16.

The selection rod 9 is inserted in the seal cylinder through the inlet opening 22, comes out of the outlet 12 and is engaged with the outlet opening 12, by means of the engaging teeth 18 themselves, so hindering a removal of the selection rod 10 and permitting a complete shaft rotation 16.

Figs. 3d, 3e, 3f and 3g illustrate four sections according to axis K, L, M, N, respectively, which show the form of the four passages P1, P2, P3, P4. Said passages P1, P2, P3, P4 have an increasing width and are so positioned for allowing the conduit 23 to communicate with one or more vents S1, S2, S3, S4 of columns R1, R2, R3, R4 by means of subsequent rotations of the selection rod 9. Therefore, configurations of passages P1, P2, P3, P4 allows an initial position V1, where all vents S1, S2, S3, S4 are plugged by the selection rod 9 and specifically by the resilient cylinder 19, which is made of a material to favour air seal. Under this usage condition, only the section RN can be filled with water. If the selection rod 9 of selector 8 is brought to position V2 (using a screwdriver on seat 20), the passage P1 will be in line with the vent S1 and let the column R1 to be filled, thus increasing the water volume available for the resins regeneration. In this position, all other vents S2, S3, S4 will be plugged by the selection rod 10. If the selection rod 9 of selector 8 is brought to position V3, the passage P1, having a large angular opening, will always have a portion in line with the vent S1, whereas the passage P2 comes in line with the vent S2, leaving the column R2 available for water filling. It is then possible to go through positions V4 and V5, putting the other passages P3 and P4 in line with vents S3 and S4, respectively. Since the angular openings of passages P1, P2, P3 and P4 are decreasing, the position V5 will have all passag-

es P1, P2, P3, P4 with at least a portion facing their relevant vents S1, S2, S3, S4, so that all columns R1, R2, R3, R4 become available for filling.

From the given description, the characteristics and the advantages of the present invention are clear.

The softening system described above by way of example allows the selection of the water volume for regeneration purposes, which is simple, clear and above all easily accessible, although the selector is directly in contact with the water metering tank, or manufactured integrally with said tank. In fact, the selection rod can easily reach the front of the washing machine, making its access extremely easy with the aid of a screwdriver. This means a great advantage, since with the selector described above it is possible to select the water volume for resin regeneration actuating a compact and sturdy control element, being available on the control panel of the washing machine. This is also beneficial for the installer of the machine or for service and maintenance operators or for users themselves, who can eventually operate with the aid of a simple and clear control element, in case of a malfunction of the washing machine.

Moreover, the water softening system described above by way of example allows a most flexible selection of the water volumes to be used for resin regeneration, which may be changed according to requirements, without any restrictions due to manufacturing problems, such as in the instance where small tubes are required. Also, adjustments are fully reversible and can be made any time.

Finally, the selector is of a very simple manufacturing, being mainly obtained during the tank moulding process, except for the selection rod.

Another advantage is that no components may come off (such as small pipes), be lost or get broken, jeopardizing the operation of the softening system.

It is obvious that many changes to the water softening system in a dishwashing machine as described by way of example are possible for those skilled in the art, without departing from the novelty principles of the innovative idea, and it is also clear that in its practical actuation the forms and size of the components shown here may be different and be replaced by technical equivalent elements.

The number of columns can be larger or smaller, according to the requirements and control degree to be achieved.

Similarly, the form and arrangement of the passages on the selection rod may differ, as it is also for the opening and closing sequence of the column vents.

In a likely embodiment of the present invention, the selection rod may be rotated by a proper knob instead of using a screwdriver.

Claims

1. Water softening system in a dishwashing machine

of the type comprising a decalcifier device of water from the mains, containing decalcifying resins, a salt container to produce a saline solution for regenerating the resins contained in the decalcifier device, a container for the metering of regeneration water having a plurality of tanks to supply volumetrically defined amounts of water to the salt container, for producing the regenerating saline solution, said tanks, which are so arranged to be filled up in parallel, being of the air trap type and having upper vents, whose opening determines the filling of said tanks, characterized in that a selector (8) is provided, being integral with the container (1), which can take a plurality of working positions (V1, V2, V3, V4, V5), each one of said working positions (V1, V2, V3, V4, V5) corresponding to the opening of a different combination of vents (S1, S2, S3, S4) of the tanks (R1, R2, R3, R4).

5

10

15

20

25

30

35

40

45

50

55

2. Water softening system in a dishwashing machine according to claim 1, characterized in that the selector (8) comprises a selection rod (9) inserted in a seal cylinder (10).

3. Water softening system in a dishwashing machine according to claim 2, characterized in that the seal cylinder (10) communicates with the tanks (R1, R2, R3, R4) through the vents (S1, S2, S3, S4).

4. Water softening system in a dishwashing machine according to claim 3, characterized in that the selection rod (9) comprises a shaft (16) and a seal cylinder (19) around the shaft (16).

5. Water softening system in a dishwashing machine according to claim 4, characterized in that in the shaft (16) and the seal cylinder (19) passages (P1, P2, P3, P4) are defined, leading to a conduit (23) which communicates with the external atmosphere.

6. Water softening system in a dishwashing machine according to claim 5, characterized in that said passages (P1, P2, P3, P4) have a different size and orientation between themselves.

7. Water softening system in a dishwashing machine according to claim 5, characterized in that the selector (8), located in each one of the various working positions (V1, V2, V3, V4, V5), puts one or more vents (S1, S2, S3, S4) in line with the relevant passage (P1, P2, P3, P4).

8. Water softening system in a dishwashing machine according to claim 6, characterized in that at least a working position (V5) is provided, in which the vents (S1, S2, S3, S4) are all plugged by means of the seal cylinder (19).

9. Water softening system in a dishwashing machine according to claim 2, characterized in that an end (17) of the selection rod (9) has adjustment means (20). 5
10. Water softening system in a dishwashing machine according to claim 9, characterized in that said adjustment means (20) consist of a seat for the actuation through a screwdriver. 10
11. Water softening system in a dishwashing machine according to claim 9, characterized in that said adjustment means (20) consist of a knob. 15
12. Water softening system in a dishwashing machine according to claim 9, characterized in that said adjustment means (20) are located outside the washing machine. 20
13. Water softening system in a dishwashing machine according to claim 7, characterized in that the shaft (16) has at least an indentation (22) whose shape is apt to engage in grooves (15) obtained on the seal cylinder (10), where in particular said grooves (15) are in line with the working positions (V1, V2, V3, V4, V5) and the indentation (22) provides a steady selection of the desired working positions (V1, V2, V3, V4, V5) by engaging in said grooves (15). 25 30
14. Water softening method in a dishwashing machine, of the type comprising a water decalcifier device, a regeneration device for the resins contained in said decalcifier device, a tank for the water to be supplied to said resin regeneration device, of the type having air trap compartments, characterized in that said air trap compartments (R1, R2, R3, R4) are pre-set for water filling through the opening of vents (S1, S2, S3, S4) by actuating a selector (8) having a plurality of working positions (V1, V2, V3, V4, V5) and that by positioning the selector (8) on each working position (V1, V2, V3, V4, V5) a different opening and closing state of the vents (S1, S2, S3, S4) is determined, which through their relevant passages (P1, P2, P3, P4) in the selector (8) may be connected with a conduit (23) communicating with the external atmosphere. 35 40 45
15. Method, according to the previous claim, characterized in that by placing the selector (8) on each subsequent working position (V1, V2, V3, V4, V5), a progressive opening of the vents (S1, S2, S3, S4) is determined. 50 55

FIG. 1

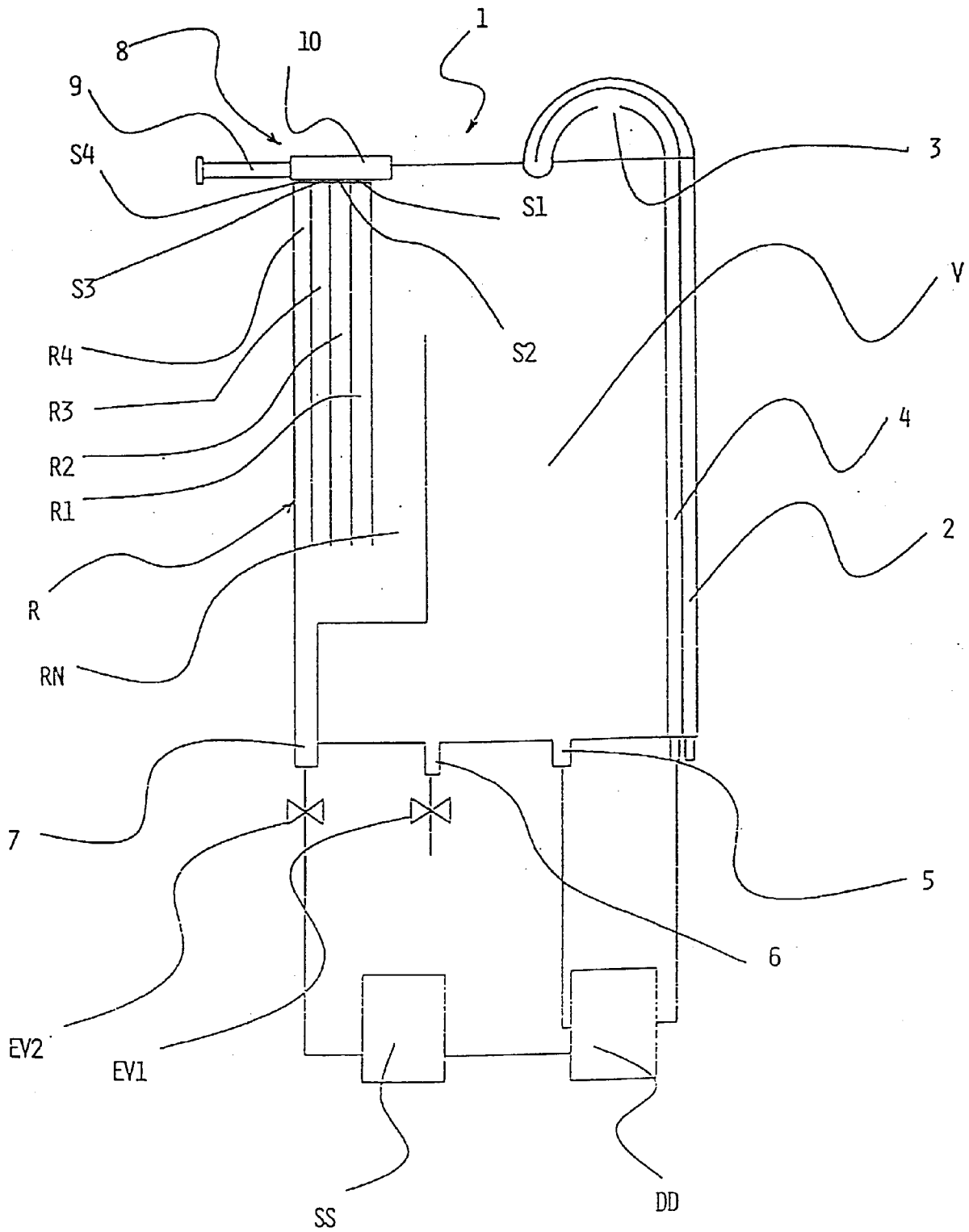

FIG. 2

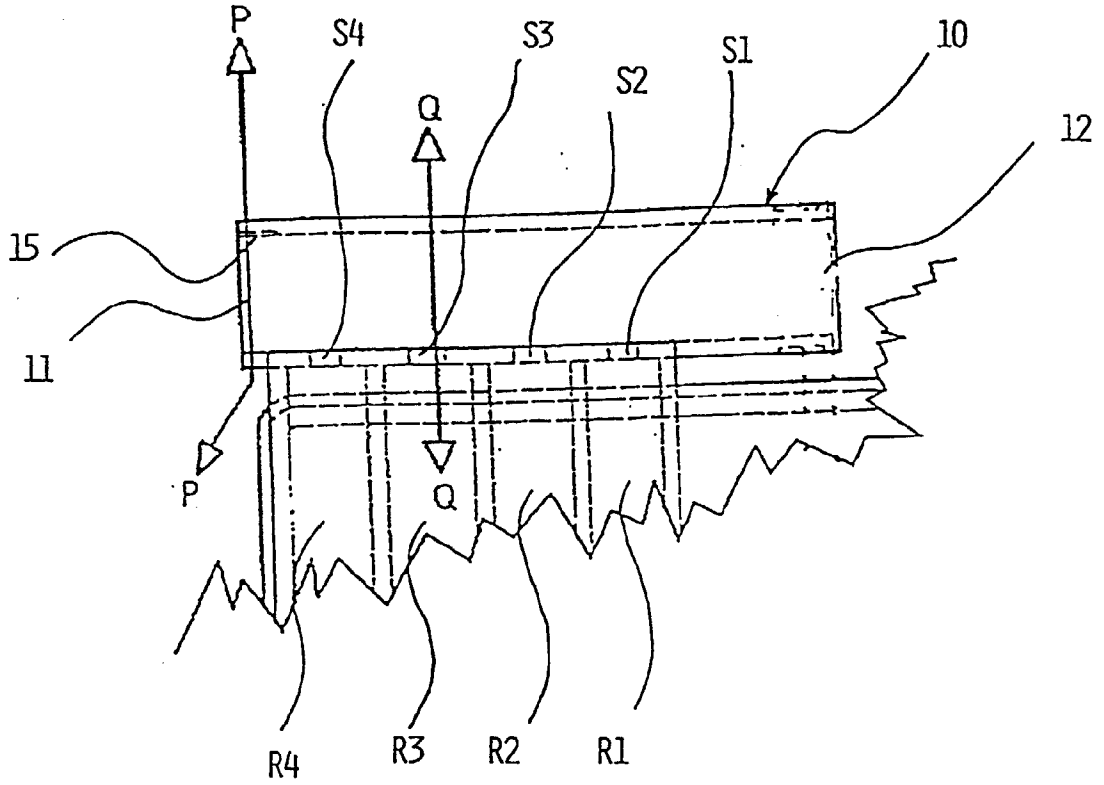

FIG. 2B

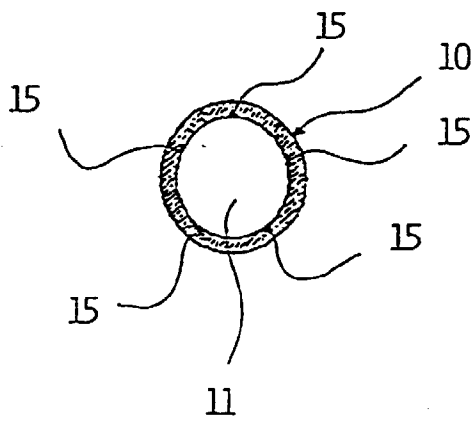

FIG. 2A

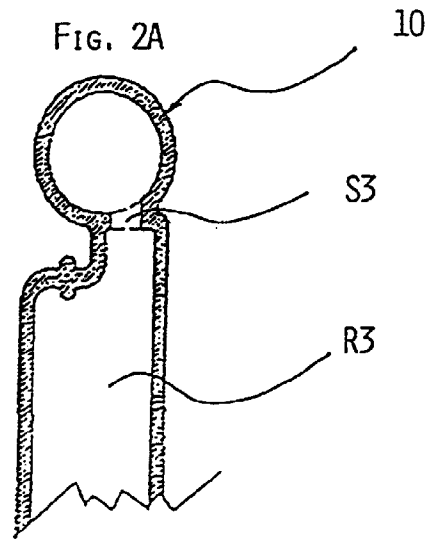

FIG. 3

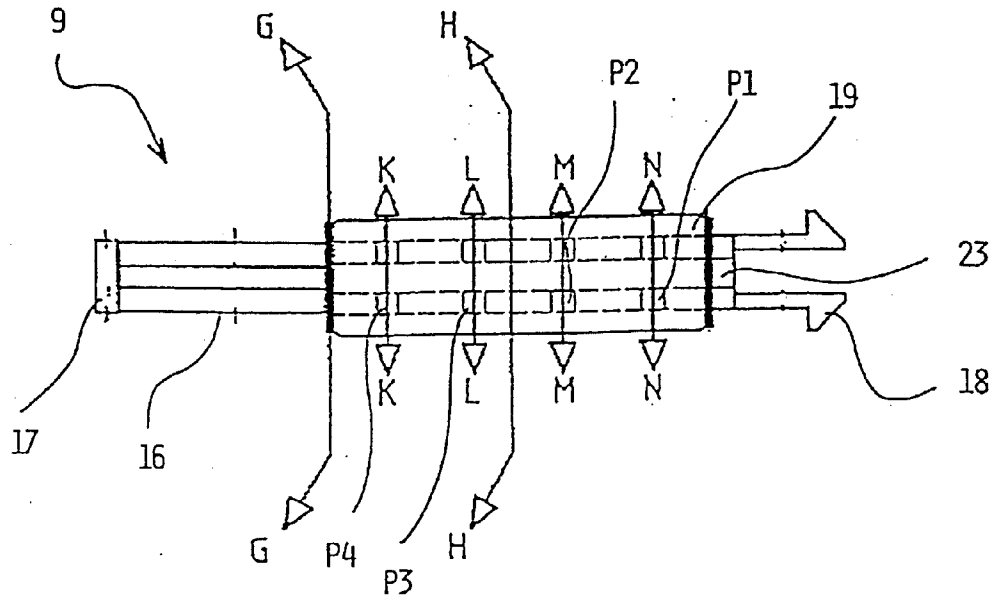

FIG. 3A

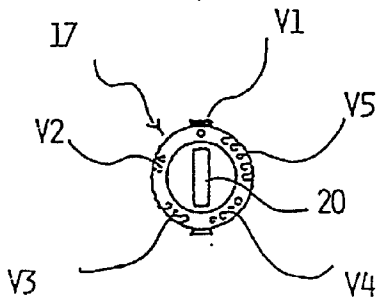

FIG. 3B

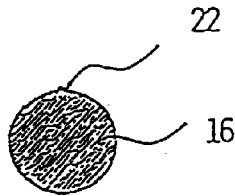

FIG. 3C

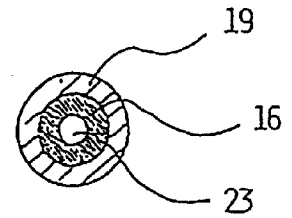

FIG. 3D

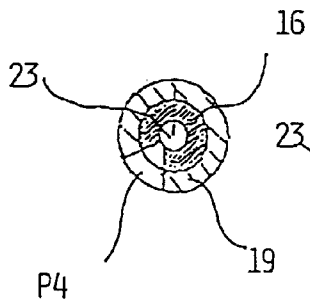

FIG. 3E

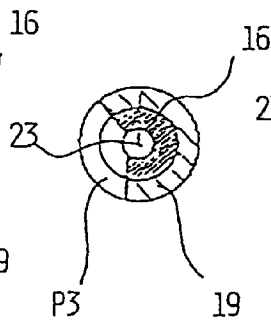

FIG. 3F

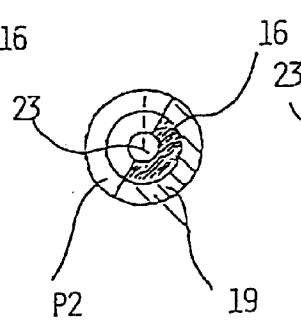

FIG. 3G

