



Europäisches Patentamt
European Patent Office
Office européen des brevets



(11) **EP 1 127 810 A2**

(12) **EUROPEAN PATENT APPLICATION**

(43) Date of publication:
29.08.2001 Bulletin 2001/35

(51) Int Cl.7: **B65D 81/34**

(21) Application number: **01300620.0**

(22) Date of filing: **24.01.2001**

(84) Designated Contracting States:
**AT BE CH CY DE DK ES FI FR GB GR IE IT LI LU
MC NL PT SE TR**
Designated Extension States:
AL LT LV MK RO SI

(72) Inventor: **Hiyoshi, Sachiko**
Tokyo 112-0006 (JP)

(74) Representative: **Jones, Helen Marjorie Meredith**
Gill Jennings & Every,
Broadgate House,
7 Eldon Street
London EC2M 7LH (GB)

(30) Priority: **01.02.2000 JP 2000023830**

(71) Applicant: **Hiyoshi, Sachiko**
Tokyo 112-0006 (JP)

(54) **Vented food container**

(57) The present invention provides a container (1) for packaging food, in which a sheet (4) seals a vent hole (3) formed at a portion of the container (1) cannot so easily be peeled off but, when the food is heated by an microwave oven, the sheet (4) automatically comes off at the time when the food contained in the container has reached the adequately cooked state. Specifically, the present invention is produced by enclosing food,

which contains water or an aqueous solution, in the container for packaging food, the container (1) for packaging food having, on one side thereof, a surface portion (2) made of plastic sheet, at least one vent hole (3), the vent hole being sealed by an adhesive hole-sealing sheet (5) whose vertical peeling strength is no less than 1N/cm in the temperature range of 40°C or lower and is no higher than 0.1N/cm at the temperature range of 80°C or higher.

EP 1 127 810 A2

DescriptionBACKGROUND OF THE INVENTION

5 Field of the Invention

[0001] The present invention relates to a packaged food which is produced by enclosing unfrozen or frozen food in an airtight container such that the packaged food can be directly cooked by heating in a microwave oven. The present invention also relates to a container for packaging food in which the aforementioned food can be enclosed for storage.

10

Prior Art

15

[0002] Packaged food produced by enclosing unfrozen food (i.e., food at the room temperature) or frozen food in a container for storage is conventionally known. It is also known that, when such packaged food is heated in a microwave oven, the pressure inside the package significantly rises up, to increase the possibility of the package exploding. Therefore, it has been proposed a technique for preventing explosion, in which holes are formed in the container for packaging food such that each hole is covered by a circular-shaped sealing piece coated with an adhesive (Japanese Utility Model 62-69466). Similarly, a technique has been proposed in which holes are formed in the container which packages food, and a valve sheet is attached, so as to close each hole, by applying a first adhesive having a low melting point which corresponds to the heating temperature of the food in the range between the periphery of the hole and the valve sheet end periphery, and by applying a second adhesive which does not melt at the heating temperature of the food at two sides of the low-melting point adhesive-applied portion (Japanese Utility Model 63-156978).

20

25

[0003] These known techniques are useful for prevention of explosion during heating by an microwave oven. However, in these conventional techniques, there arises a problem that the holes are opened before the food is sufficiently heated and thus uneven heating is caused or a problem that the holes are opened so late to cause drying or burning of food. These problems have not been solved. Therefore, in the packaged food to be cooked by heating by a microwave oven, there has been a demand for a sealing structure of the holes, in which steam generated by heating the food is preserved for an appropriate period without allowing the steam to escape outside too early and the sealing is released only when the food is sufficiently heated. However, it is not so easy to determine the most preferable sealing condition of holes with respect to each (type of) food. In addition, such a supposed-to-be-preferable sealing structure tends to have a complicated structure. In short, no prior art has successfully developed a technique which satisfies the aforementioned demand in an economical and practical manner.

30

SUMMARY OF THE INVENTION

35

[0004] In order to satisfy the aforementioned demand, the present invention intends to provide, in an economical manner, a sealing structure in which a hole-sealing sheet for sealing a vent hole formed in a container for packaging food automatically comes off, at the most preferable timing, when the food is cooked by heating by an microwave oven.

40

[0005] A first object of the present invention is to provide a packaged food, in which a hole-sealing sheet covering a vent hole formed at a portion of a container is not so easily peeled off when the container is preserved at the room temperature or the freezing condition but the hole-sealing sheet automatically comes off, when the food is heated by an microwave oven, substantially at the time when the food contained in the container has reached an adequately cooked state.

45

[0006] A second object of the present invention is to provide a container for packaging food, which container is provided with at least one vent hole and used for producing packaged food by enclosing food therein, and in which container a hole-sealing sheet covering the vent hole is not so easily peeled off when the container is preserved at the room temperature or the freezing condition but the hole-sealing sheet automatically comes off, when the food is heated by an microwave oven, substantially at the time when the food contained in the container has reached an adequately cooked state. That is, the second object of the present invention is to provide a container for packaging food which enables carrying out the most preferable heating of the food by flexibly adapting, in function thereof, to the various heating conditions by a microwave oven which is selected according to the contained food.

50

55

[0007] The packaged food of the present invention, which can achieve the aforementioned first object, is characterized in that food containing water or an aqueous solution is enclosed in a container, the container having, on one side thereof, a surface portion made of plastic sheet, at least one vent hole being formed in the vicinity of the center of the surface portion, the vent hole being sealed by an adhesive hole-sealing sheet whose vertical peeling strength is no less than 1 N/cm in the temperature range of 40°C or lower and is no higher than 0.1 N/cm at the temperature range of 80°C or higher.

[0008] In addition, the container for packaging food of the present invention, which can achieve the aforementioned

second object, is characterized in that the container has, on one side thereof, a surface portion made of plastic sheet, at least one vent hole being formed in the vicinity of the center of the surface portion, the vent hole being sealed by an adhesive hole-sealing sheet whose vertical peeling strength is no less than 1 N/cm in the temperature range of 40°C or lower and is no higher than 0.1 N/cm at the temperature range of 80°C or higher.

[0009] Further, the hole-sealing sheet of the container for packaging food of the present invention is preferably made of white chemical paper used as a base material. It is preferable that the vent hole formed in the container is sealed by the hole-sealing sheet such that the adhesive layer having uneven width provided in the hole-sealing sheet covers the periphery of the vent hole.

BRIEF DESCRIPTION OF THE DRAWINGS

[0010]

Fig. 1 is a sectional view of a vent hole portion formed in a lid of a container for packaging food of the present invention; and

Fig. 2 is a perspective view which shows a structure of a container for packaging food of the present invention.

DETAILED DESCRIPTION OF THE PREFERRED EMBODIMENT

[0011] Packaged food of the present invention is intended to represent packaged food which can be cooked by heating by a microwave oven. At least one vent hole is provided in a container for packaging food so that, when the pressure inside the container is increased in heating the food due to volume increase in the air in the container and generation of steam, the increased pressure is reduced by releasing the steam and occurrence of explosion is prevented. In the present invention, the vent hole is sealed by a hole-sealing sheet having adhesives thereon. That is, the present invention has been achieved by utilizing and improving the conventional technique.

[0012] Food in the container must be sufficiently heated in cooking. Therefore, it is unavoidable that the pressure inside the container rises up to the value of the vapor pressure which corresponds to the temperature of the food, because the pressure inside the container increases as the temperature in the container is increased. Considering this situation, the known conventional techniques make the adhesive strength of the hole-sealing sheet relatively weak or provide, the periphery portion of the vent hole or the like, with portions where the adhesive strength is relatively weak, so that the hole-sealing sheet easily comes off when the pressure inside the container has become high. In other words, such conventional techniques expect the hole-sealing sheet to operate as a safe valve for pressure.

[0013] The inventors of the present invention have assiduously studied a problem that it is not easy to make the preferable finished state of cooking by heating correspond with the pressure resistance properties of the hole-sealing sheet. As a result of the study, the inventors have discovered that the pressure resistance properties of the hole-sealing sheet can be changed by adjusting the temperature properties of adhesive strength of the adhesive agent (the adhesive agent is used for attaching the hole-sealing sheet). The present invention has been achieved on the basis of this discovery.

[0014] The container for packaging food of the present invention may have a box-like shape or a bag-like shape. That is, the shape of the container is not limited to any particular form and any structure is acceptable as long as the container is formed by using a material which is excellent in airtight, watertight, oil resistant and heat resistant properties, is electromagnetic wave-transmittable, and has mechanical strength of appropriate level. However, at least one side surface of the container must be formed by a plastic sheet. The surface formed by a plastic sheet is preferably transparent so that the content therein can be seen.

[0015] Examples of the plastic material to be used for forming the container as described above include: a single material sheet or a composite material sheet containing, as main components, polypropylene, polyester, polysulfone, polyamide (nylon), polycarbonate and the like; and a laminated layer-composite sheet in which the aforementioned single material or composite material sheet is combined with polyacrylate, polyvinylidene chloride, polyvinyl alcohol and the like.

[0016] A vent hole is formed in the plastic sheet surface made of the aforementioned materials. The vent hole is preferably formed in the vicinity of the center of the container for packaging food (in the vicinity of the center of the upper surface, in a case of a flat-type container in which the height is relatively small as compared with the longitudinal/lateral dimensions thereof) in terms of evenly heating the content in the container. The vent hole may have any shape such as circular, ellipsoidal, oval or polygonal shape, as long as the shape is suitable for the purpose. The size of the diameter of the vent hole is preferably 5 mm or so, but is not particularly limited.

[0017] Similar to the plastic sheet described above, the hole-sealing sheet for sealing the vent hole is preferably made of a base material having excellent airtight, watertight, oil resistance and heat resistance properties. Examples of such a base material include a sheet made of polyester, polypropylene or the like, a synthetic paper and a chemical

paper made of plastic materials. It is preferable that the hole-sealing sheet itself hardly generates heat when it is hit by electromicrowaves nor increases its temperature when it absorbs infrared light. The hole-sealing sheet having aluminum deposited thereon so as to reflect microwaves and the hole-sealing sheet which is colorless or, in particular, white is especially preferable. The hole-sealing sheet may have any suitable shape such as circular or ellipsoidal shape. The size of the diameter of the hole-sealing sheet is preferably 10 mm or so, but it is not limited to this size.

[0018] The adhesive agent for attaching the hole-sealing sheet to the vent hole formed in the plastic sheet must be an adhesive agent having stickiness with respect to the plastic sheet, i.e., a pressure sensitive adhesive. Examples of such a pressure sensitive adhesive agent include natural rubber, synthetic rubber. A pressure sensitive adhesive, which is produced by blending styrene butadiene-based rubber and acryl-based rubber with a rosin-based or petroleum resin-based stickiness-providing material so as to have both excellent pressure sensitive properties and excellent thermosensitive properties, is particularly preferable for use.

[0019] The pressure sensitive adhesive as described above is required to have thermosensitive properties in which the vertical peeling strength is no less than 1 N/cm or preferably no less than 2 N/cm in the temperature range of 40°C or lower and is no higher than 0.1 N/cm in the temperature range of 80°C or higher. By employing the hole-sealing sheet having a back surface coated with a pressure sensitive adhesive which satisfies the aforementioned conditions or properties, for sealing the vent hole formed in the plastic sheet, the hole-sealing sheet now functions so as to open the vent hole after the food contained in the container has been sufficiently cooked by heating.

[0020] It should be noted that the numerical values in the aforementioned conditions are not such numerical values which are inherent to the adhesive itself as is obtained by measurement in accordance with the standard adhesive strength testing method and the like practiced in the industry (described in JIS Z 0237, for example), but the numerical values which indicate the thermosensitive properties of adhesive strength of the hole-sealing sheet, with respect to the plastic sheet of a container for packaging food having a vent hole formed therein. Accordingly, attention should be paid because it is generally not known whether or not a pressure sensitive adhesive, which satisfies the aforementioned conditions of adhesive strength properties with respect to a specific polyester sheet, also satisfies the conditions of adhesive strength properties with respect to a specific nylon 6 sheet.

[0021] Further, the aforementioned conditions of adhesive properties are to be applied to a container for packaging food which is designed for accommodating the most common food, i.e., the food which contains water or aqueous solutions at appropriate ratios and is suitable for heating by an microwave oven. Examples of such "the most common food" include cooked food such as main meal, snack, half-cooked food and the like. Therefore, with respect to the food which needs to be heated to a relatively high temperature of no lower than 100°C or the food which needs to be heated only to 40-60°C, it is necessary that a pressure sensitive adhesive having more preferable adhesive strength properties within the aforementioned range of the conditions, is selected. Yet further, needless to say, food which is not suitable for being heated by an microwave oven such as dry foods or the like is beyond the scope of the present invention.

[0022] The present invention will be described hereinafter according to a preferred embodiment.

[0023] In Fig. 1, the reference number 1 represents a food container which is produced by molding a polycarbonate sheet. Alamine layer or the like formed by an appropriate material may be provided inside the food container 1. The reference number 2 represents a flexible lid made of nylon 6 sheet. The periphery portion of the lid 2 is designed so that the periphery portion can be fixed to the edge portion 1' of the food container 1 by melt-attaching or adhesive-attaching. A vent hole 3 having circular shape is formed in the vicinity of the center position of the lid 2. The vent hole 3 has been airtightly sealed by the hole-sealing sheet 4 having circular shape.

[0024] A pressure sensitive adhesive layer 5 which sticks to the nylon 6 sheet is provided on the back surface of the hole-sealing sheet 4, such that a non-adhesive portion 5' having ellipsoidal shape is formed substantially in the center portion of the pressure sensitive adhesive layer 5. In the pressure sensitive adhesive layer 5, the width of the portion coated with the pressure sensitive adhesive is made uneven. Further, the center position of the vent hole 3 does not need to coincide with that of the hole-sealing sheet 4. A slight misalignment of 1-2 mm or so between the center position of the vent hole 3 and that of the center position of the hole-sealing sheet 4 is rather preferable because such a slight misalignment facilitates, in a reliable manner, peeling of the hole-sealing sheet 4.

[0025] The hole-sealing sheet 4 used here is produced by: preparing, as a base material, synthetic paper made of polyester which has thickness of 60 μm and white surface coating applied thereon; and coating the base material with an acryl-based pressure sensitive adhesive a so that the thickness of the adhesive a is 25 μm, thereby forming the pressure sensitive adhesive layer 5. For comparison, a hole-sealing sheet 4b and a hole-sealing sheet 4c were produced by coating the base material with another acryl-based pressure sensitive adhesive b or a styrene butadiene-based pressure sensitive adhesive c, respectively, so that the thickness of the adhesives b, c is each 25 μm and the pressure sensitive adhesive layer is formed in each of a hole-sealing sheet 4b and a hole-sealing sheet 4c in a manner similar to the hole-sealing sheet 4a.

[0026] The adhesive strength properties of the aforementioned pressure sensitive adhesives a, b, c with respect to the nylon 6 sheet were measured separately. The results are as follows.

Table 1

| Adhesive Strength with respect to Nylon 6 Sheet (10^{-2} N/cm) | | | | | | | |
|---|-----|-----|-----|-----|----|----|----|
| Temperature (°C) | 30 | 40 | 50 | 60 | 70 | 80 | 90 |
| Pressure Sensitive Adhesive a | 300 | 190 | 110 | 38 | 13 | 8 | 5 |
| Pressure Sensitive Adhesive b | 220 | 85 | 43 | 18 | 9 | 2 | - |
| Pressure Sensitive Adhesive c | 350 | 240 | 175 | 130 | 92 | 63 | 42 |

[0027] The hole-sealing sheet 4a, the hole-sealing sheet 4b and the hole-sealing sheet 4c produced by coating the base material with the pressure sensitive adhesives a, the pressure sensitive adhesives b, the pressure sensitive adhesives c, respectively, were each pressingly attached to the vent hole 3 of the lid 2 made of nylon 6 sheet of a food container so as to seal the vent hole 3 (the three food containers for the three adhesives used here had substantially the same structure except for the hole-sealing sheet), thereby producing a container for packaging food A of the present invention and containers for packaging food B, C as comparative examples. Five samples were prepared for each of the container for packaging food A, B and C. 210 g of frozen Shao-mai was airtightly enclosed in each container and the heat-cooking tests were carried out by using a microwave oven which satisfied the standard of output measurement of a microwave oven described in JIS Z 9212. The results shown in Table 2 were obtained.

Table 2

| Heat-Cooking Test of Packaged Food | | |
|------------------------------------|---|---|
| Food Container | Time required the Hole-Sealing Sheet to come off (minute) | The heat-cooked State of Food |
| A | 4.5-5.0 | Evenly heated all over |
| B | 3.5-4.0 | Core Portion has not been sufficiently heated |
| C | 7.0-7.5 | Surface has been dried |

[0028] From the results described above, it is understood that the packaged food of the present invention prepared by using the container for packaging food of the present invention reliably prevents, when the packaged food is heated by a microwave oven, the hole-sealing sheet thereof from peeling off at the time when the food has not sufficiently been heated. In the present invention, the hole-sealing sheet peels off only when the food has reached an adequately cooked state, an enough amount of steam is generated and, due to the steam, the temperature at the vent hole portion has reached the temperature at which the pressure sensitive adhesive peels off. Therefore, by stopping the operation of the microwave oven when the steam has burst, there is no possibility of overheating the food.

[0029] As described above, the packaged food of the present invention is produced by enclosing food containing water or an aqueous solution in the container for packaging food of the present invention, the container for packaging food having, on one side thereof, a surface portion made of plastic sheet, at least one vent hole being formed in the vicinity of the center of the surface portion, the vent hole being sealed by an adhesive hole-sealing sheet whose vertical peeling strength is no less than 1 N/cm in the temperature range of 40°C or lower and is no higher than 0.1 N/cm at the temperature range of 80°C or higher. When the packaged food of the present invention is heated by using a microwave oven, the hole-sealing sheet thereof automatically peels off after the food has been sufficiently heated. Therefore, the hole-sealing sheet peeling off before the cooking by heat has been completed or the overcooking of the food due to too late peeling of the hole-sealing sheet will less likely to occur. In other words, the present invention achieves an excellent effect that adequately cooked food can be easily obtained.

Claims

1. A packaged food characterized in that food containing water or an aqueous solution is enclosed in a container, the container having a surface portion made of plastic sheet, at least one vent hole being formed in the surface portion, the vent hole being sealed by an adhesive hole-sealing sheet whose vertical peeling strength is no less than 1 N/cm in the temperature range of 40°C or lower and is no higher than 0.1 N/cm at the temperature range of 80°C or higher.
2. A container for packaging food characterized in that the container has a surface portion made of plastic sheet, at

EP 1 127 810 A2

least one vent hole being formed in the surface portion, the vent hole being sealed by a hole-sealing sheet adhered to the surface portion by an adhesive layer, the vertical peeling strength of the hole sealing object being no less than 1 N/cm in the temperature range of 40°C or lower and no higher than 0.1 N/cm at the temperature range of 80°C or higher.

- 5
3. A container for packaging food of claim 2, wherein the at least one vent hole is formed in the vicinity of the center of a surface portion provided on one side of the container.
- 10
4. A container according to claim 2 or claim 3 in which the said adhesive layer extends around the entire periphery of the vent hole and which the hole-sealing sheet is adhered to the surface portion by the said adhesive layer only.
5. A container for packaging food of any of claims 2 to 4, wherein the adhesive layer has uneven width around the periphery of the vent hole.
- 15
6. A container for packaging food of any of claims 2 to 5, wherein the hole-sealing sheet is made of white chemical paper used as a base material.
7. A container according to claim 6 in which the said base material comprises polyester.
- 20
8. A container according to any of claims 2 to 7 in which the said plastic sheet comprises polyamide.
9. A container according to any of claims 2 to 8 in which the adhesive layer is formed of a blend of styrenebutadiene-based rubber and/or acryl-based rubber with a resin-based or petroleum resin-based adhesion additive.

25

30

35

40

45

50

55

Fig. 1

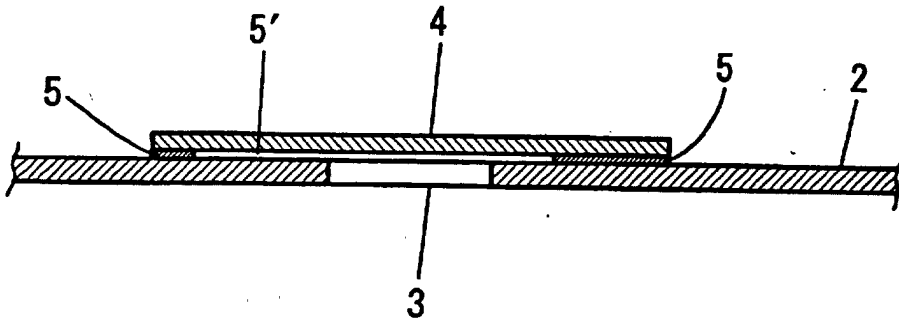

Fig. 2

