



(51) International Patent Classification:
A61M 1/00 (2006.01)

(21) International Application Number:
PCT/US2019/013675

(22) International Filing Date:
15 January 2019 (15.01.2019)

(25) Filing Language: English

(26) Publication Language: English

(30) Priority Data:
62/652,754 04 April 2018 (04.04.2018) US

(71) Applicant: KCI LICENSING, INC. [US/US]; Legal Department-Intellectual Property, P.O. Box 659508, San Antonio, TX 78265-9508 (US).

(72) Inventors: LONG, Justin, Alexander; 8 Dorchester Place, 64 Lansdowne Road, Bournemouth BH1 1PP (GB). LOCKE, Christopher, Brian; 6 Bosworth Mews, Bournemouth BH9 3SD (GB).

(74) Agent: WELCH, Gerald, T. et al.; Harness, Dickey & Pierce, P.L.C., 5445 Corporate Drive, Suite 200, Troy, MI 48098 (US).

(81) Designated States (unless otherwise indicated, for every kind of national protection available): AE, AG, AL, AM, AO, AT, AU, AZ, BA, BB, BG, BH, BN, BR, BW, BY, BZ, CA, CH, CL, CN, CO, CR, CU, CZ, DE, DJ, DK, DM, DO, DZ, EC, EE, EG, ES, FI, GB, GD, GE, GH, GM, GT, HN, HR, HU, ID, IL, IN, IR, IS, JO, JP, KE, KG, KH, KN, KP, KR, KW, KZ, LA, LC, LK, LR, LS, LU, LY, MA, MD, ME, MG, MK, MN, MW, MX, MY, MZ, NA, NG, NI, NO, NZ, OM, PA, PE, PG, PH, PL, PT, QA, RO, RS, RU, RW, SA,

(54) Title: SYSTEMS AND METHODS FOR CONTROLLING NEGATIVE PRESSURE THERAPY WITH FLUID INSTILLATION THERAPY AND CLEANSING

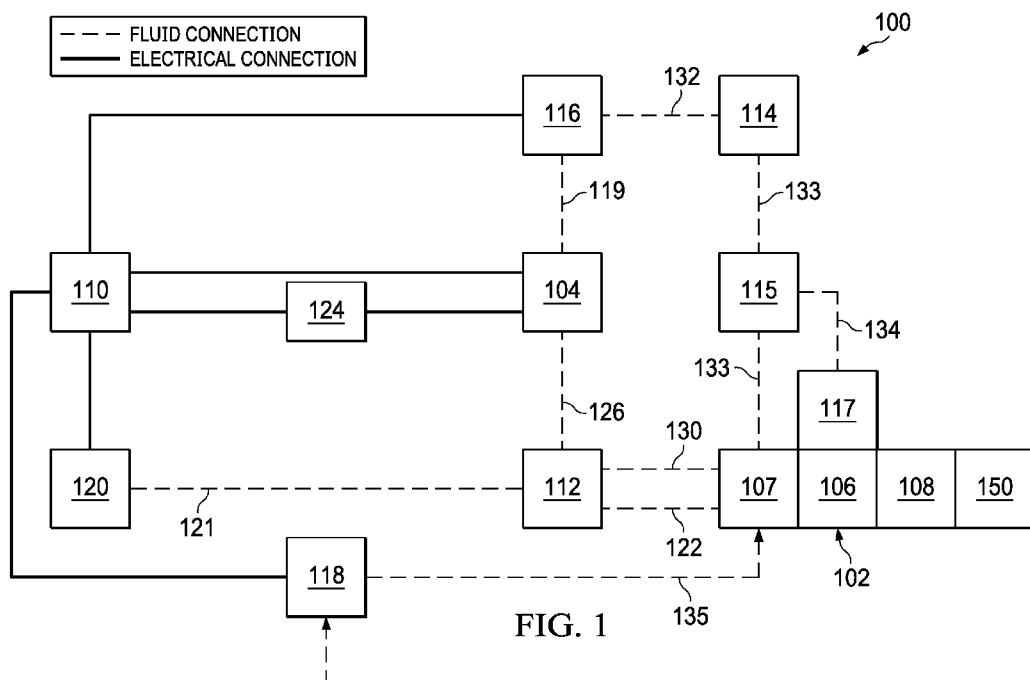

(57) Abstract: Systems, apparatuses, and methods for providing negative pressure and/or instillation fluids to a tissue site are disclosed. Some embodiments are illustrative of an apparatus or system for delivering negative-pressure and/or therapeutic solution of fluids to a tissue site, which can be used in conjunction with sensing properties of fluids extracted from a tissue site and/or instilled at a tissue site. For example, an apparatus may comprise a dressing interface or connector that includes a pH sensor, a humidity sensor, a temperature sensor and/or a pressure sensor embodied on a single pad within the connector and proximate the tissue site to provide data indicative of acidity, humidity, temperature and pressure. Such apparatus may further comprise algorithms for processing such data for detecting leakage and blockage as well as providing information relating to the progression of healing of wounds at the tissue site. An illustrative method may comprise positioning a dressing interface having a pH sensor, a temperature sensor, a humidity sensor, and a pressure



SC, SD, SE, SG, SK, SL, SM, ST, SV, SY, TH, TJ, TM, TN,
TR, TT, TZ, UA, UG, US, UZ, VC, VN, ZA, ZM, ZW.

(84) Designated States (*unless otherwise indicated, for every kind of regional protection available*): ARIPO (BW, GH, GM, KE, LR, LS, MW, MZ, NA, RW, SD, SL, ST, SZ, TZ, UG, ZM, ZW), Eurasian (AM, AZ, BY, KG, KZ, RU, TJ, TM), European (AL, AT, BE, BG, CH, CY, CZ, DE, DK, EE, ES, FI, FR, GB, GR, HR, HU, IE, IS, IT, LT, LU, LV, MC, MK, MT, NL, NO, PL, PT, RO, RS, SE, SI, SK, SM, TR), OAPI (BF, BJ, CF, CG, CI, CM, GA, GN, GQ, GW, KM, ML, MR, NE, SN, TD, TG).

Published:

— *with international search report (Art. 21(3))*

sensor at a tissue site, and applying reduced pressure to the dressing interface to draw fluids from the tissue interface in contact with the sensors to sense the pH, temperature, humidity, and pressure properties of the fluids flowing from the tissue site. The method may further comprise providing fluid data indicative of such properties to a control device for processing the fluid data and transmitting the data to another component in the system.

**SYSTEMS AND METHODS FOR CONTROLLING NEGATIVE PRESSURE
THERAPY WITH FLUID INSTILLATION THERAPY AND CLEANSING**

RELATED APPLICATION

[0001] This application claims the benefit, under 35 USC § 119(e), of the filing of U.S. Provisional Patent Application serial number 62/652,754, entitled “SYSTEMS AND METHODS FOR CONTROLLING NEGATIVE PRESSURE THERAPY WITH FLUID INSTILLATION THERAPY AND CLEANSING,” filed April 04, 2018, which is incorporated herein by reference for all purposes.

TECHNICAL FIELD

[0002] The invention set forth in the appended claims relates generally to tissue treatment systems and more particularly, but without limitation, to systems and methods for providing negative-pressure therapy with instillation of topical treatment solutions and sensing properties of wound exudates extracted from a tissue site.

BACKGROUND

[0003] Clinical studies and practice have shown that reducing pressure in proximity to a tissue site can augment and accelerate growth of new tissue at the tissue site. The applications of this phenomenon are numerous, but it has proven particularly advantageous for treating wounds. Regardless of the etiology of a wound, whether trauma, surgery, or another cause, proper care of the wound is important to the outcome. Treatment of wounds or other tissue with reduced pressure may be commonly referred to as "negative-pressure therapy," but is also known by other names, including "negative-pressure wound therapy," "reduced-pressure therapy," "vacuum therapy," "vacuum-assisted closure," and "topical negative-pressure," for example. Negative-pressure therapy may provide a number of benefits, including migration of epithelial and subcutaneous tissues, improved blood flow, and micro-deformation of tissue at a wound site. Together, these benefits can increase development of granulation tissue and reduce healing times.

[0004] There is also widespread acceptance that cleansing a tissue site can be highly beneficial for new tissue growth. For example, a wound can be washed out with a stream of liquid solution, or a cavity can be washed out using a liquid solution for therapeutic purposes. These practices are commonly referred to as "irrigation" and "lavage" respectively. "Instillation" is another practice that generally refers to a process of slowly introducing fluid to a tissue site and leaving the fluid for a prescribed period of time before removing the fluid. For example, instillation of topical treatment solutions over a wound bed can be combined with negative-pressure therapy to further promote wound healing by loosening soluble contaminants in a wound bed and removing infectious material. As a result, soluble bacterial burden can be decreased, contaminants removed, and the wound cleansed.

[0005] While the clinical benefits of negative-pressure therapy and instillation therapy are widely known, improvements to therapy systems, components, and processes may benefit healthcare providers and patients.

BRIEF SUMMARY

[0006] New and useful systems, apparatuses, and methods for instilling fluid to a tissue site in a negative-pressure therapy environment are set forth in the appended claims. Illustrative embodiments are also provided to enable a person skilled in the art to make and use the claimed subject matter. Some embodiments are illustrative of an apparatus or system for delivering negative-pressure and therapeutic solution of fluids to a tissue site, which can be used in conjunction with sensing properties of wound exudates extracted from a tissue site. For example, an apparatus may include a pH sensor, a humidity sensor, a temperature sensor and a pressure sensor embodied on a single pad proximate the tissue site to provide data indicative of acidity, humidity, temperature and pressure. Such apparatus may further comprise an algorithm for processing such data for detecting leakage and blockage as well as providing information relating to the progression of healing of wounds at the tissue site.

[0007] In some embodiments, for example, an apparatus may include a dressing interface for connecting a source of fluids to a tissue interface and sensing properties of fluids extracted from a tissue site. The dressing interface may comprise a housing having a body including an outside surface and a therapy cavity therein, and the therapy cavity may have an opening configured to be in fluid communication with the tissue interface. The dressing interface may further comprise a reduced-pressure port fluidly coupled to the therapy cavity and adapted to fluidly couple a reduced-pressure source to the tissue interface, and an instillation port fluidly coupled to the therapy cavity and adapted to fluidly couple an instillation source to the tissue interface. The dressing interface may further comprise a control device having a microprocessor and a wireless transmitter disposed on the housing outside of the therapy cavity, wherein the wireless transmitter module is electrically coupled to the processor. The dressing may further comprise a pressure sensor having a sensing portion disposed within the therapy cavity and electrically coupled to the microprocessor through the body of the housing, and also a pH sensor having a sensing portion disposed within the therapy cavity and electrically coupled to the microprocessor through the body of the housing.

[0008] In some embodiments, the dressing interface may further comprise a vent port fluidly coupled to the therapy cavity and adapted to enable airflow into the therapy cavity. In such embodiment, the dressing interface may further comprise a fluid conductor fluidly coupled to the reduced-pressure port and the vent port. In such embodiments, the fluid

conductor may comprise side-by-side lumens including a primary lumen fluidly coupled to the reduced-pressure port and at least one auxiliary lumen fluidly coupled to the vent port.

[0009] The dressing interface may further comprise a first baffle disposed proximate the reduced-pressure port and a second baffle disposed proximate the installation port, both extending into the therapy cavity to direct the flow of fluids within the therapy cavity. The dressing interface may further comprise a temperature sensor and a humidity sensor, each sensor having a sensing portion disposed within the therapy cavity and electrically coupled to the microprocessor through the body of the housing. The sensing portion of the humidity sensor and the temperature sensor may be disposed proximate the instillation port.

[0010] In some embodiments of the dressing interface, the sensing portion of the pressure sensor may be disposed in the therapy cavity so that the sensing portion is proximate the tissue interface when positioned at the tissue site. The sensing portion of the pH sensor may be disposed proximate the instillation port. In some embodiments, the pH sensor may comprise an electrode disposed within the therapy cavity and electrically coupled to an input of a front-end amplifier disposed on outside of the therapy cavity, wherein the front-end amplifier has an output electrically coupled to the microprocessor.

[0011] Some embodiments are illustrative of a method for providing reduced-pressure to a tissue interface and sensing properties of fluids extracted from a tissue site for treating the tissue. In one example embodiment, the method may comprise positioning a dressing interface having a housing opening to an aperture in fluid communication with the tissue interface disposed adjacent the tissue site. The dressing interface may comprise a wall disposed within the housing to form a therapy cavity within the housing and a component cavity fluidly sealed from the therapy cavity, wherein the therapy cavity opens to the aperture. Such dressing interface may further comprise a reduced-pressure port fluidly coupled to the therapy cavity and adapted to be fluidly coupled to a reduced-pressure source, and a control device disposed in the component cavity. The dressing interface may further comprise a pH sensor, a temperature sensor, a humidity sensor, and a pressure sensor, all disposed within the therapy cavity and each electrically coupled to the control device. The method may further comprise applying reduced pressure to the therapy cavity to draw fluids from the tissue interface into the therapy cavity, and sensing the pH, temperature, humidity, and pressure properties of the fluids flowing through therapy cavity utilizing the sensors. The method may further comprise providing fluid data indicative of such properties and inputting the fluid data to the control device for processing the fluid data for treating a tissue site.

[0012] Some embodiments are illustrative of a method for applying fluids to a tissue interface and sensing properties of fluids at a tissue site for treating the tissue site. For example, the method may comprise positioning a dressing interface on the tissue site, wherein the dressing interface may have a housing including an outside surface and a therapy cavity having an opening configured to be in fluid communication with the tissue interface. The dressing interface may further comprise a reduced-pressure port fluidly coupled to the therapy cavity and adapted to fluidly couple a reduced-pressure source to the therapy cavity, an instillation port fluidly coupled to the therapy cavity and adapted to fluidly couple an instillation source to the therapy cavity, and a pH sensor and a pressure sensor disposed within the therapy cavity and each electrically coupled to a control device. The method may further comprise applying reduced pressure to the therapy cavity to draw fluids from the tissue interface and into the therapy cavity, and sensing pH and pressure properties of the fluids within the therapy cavity provided from the pressure sensor and the pH sensor. The method may further comprise instilling fluids into the therapy cavity to cleanse the pressure sensor and the pH sensor.

[0013] Objectives, advantages, and a preferred mode of making and using the claimed subject matter may be understood best by reference to the accompanying drawings in conjunction with the following detailed description of illustrative embodiments.

BRIEF DESCRIPTION OF THE DRAWINGS

[0014] Figure 1 is a functional block diagram of an example embodiment of a therapy system for providing negative-pressure including both instillation and venting capabilities in accordance with this specification;

[0015] Figure 2A is a graph illustrating an illustrative embodiment of pressure control modes for the negative-pressure and instillation therapy system of Figure 1 wherein the x-axis represents time in minutes (min) and/or seconds(sec) and the y-axis represents pressure generated by a pump in Torr (mmHg) that varies with time in a continuous pressure mode and an intermittent pressure mode that may be used for applying negative pressure in the therapy system;

[0016] Figure 2B is a graph illustrating an illustrative embodiment of another pressure control mode for the negative-pressure and instillation therapy system of Figure 1 wherein the x-axis represents time in minutes (min) and/or seconds(sec) and the y-axis represents pressure generated by a pump in Torr (mmHg) that varies with time in a dynamic pressure mode that may be used for applying negative pressure in the therapy system;

[0017] Figure 3 is a flow chart showing an illustrative embodiment of a therapy method for providing negative-pressure and instillation therapy for delivering treatment solutions to a dressing at a tissue site;

[0018] Figure 4 is a sectional side view of a first dressing interface comprising a housing and a wall disposed within the housing and forming a therapy cavity including sensors and a component cavity including electrical devices that may be associated with some example embodiments of the therapy system of Figure 1 for providing negative pressure including both instillation and venting capabilities to the therapy cavity through a single conduit;

[0019] Figure 5A is a perspective top view of the first dressing interface of Figure 4, Figure 5B is a side view of the first dressing interface of Figure 4 disposed on a tissue site, and Figure 5C is an end view of the first dressing interface of Figure 4 disposed on the tissue site;

[0020] Figure 6A is an assembly view of the first dressing interface of Figure 4 comprising components of the housing and a first example embodiment of a sensor assembly including the wall, the sensors, and the electrical devices;

[0021] Figure 6B is a system block diagram of the sensors and electrical devices comprising the sensor assembly of Figure 6A;

[0022] Figures 7A, 7B and 7C are a top view, side view, and bottom view, respectively, of the sensor assembly of Figure 6;

[0023] Figure 7D is a perspective top view of the sensor assembly of the sensor assembly of Figure 6 including one example embodiment of a pH sensor;

[0024] Figure 8A is a perspective bottom view of the first dressing interface of Figure 4, and Figure 8B is a bottom view of the first dressing interface of Figure 4;

[0025] Figure 9A is a top view of a first embodiment of a pH sensor that may be used with the sensor assembly of Figure 8D, and Figure 9B is a top view of a second embodiment of a pH sensor that may be used with the sensor assembly of Figure 8D;

[0026] Figure 10A is a sectional side view of a second dressing interface comprising a housing and a wall disposed within the housing and forming a therapy cavity including sensors and a component cavity including electrical devices that may be associated with some example embodiments of the therapy system of Figure 1 for providing negative pressure including instillation to the therapy cavity through separate ports;

[0027] Figure 10B is a sectional bottom view of the second dressing interface of Figure 10A taken along the line 10B—10B showing the sensors and baffles disposed within the therapy cavity; and

[0028] Figure 11 is a sectional bottom view of a third dressing interface which is a modified version of the second dressing interface of Figures 10A and 10B further comprising a third port for venting to the therapy cavity.

DESCRIPTION OF EXAMPLE EMBODIMENTS

[0029] The following description of example embodiments provides information that enables a person skilled in the art to make and use the subject matter set forth in the appended claims, but may omit certain details already well-known in the art. The following detailed description is, therefore, to be taken as illustrative and not limiting.

[0030] The example embodiments may also be described herein with reference to spatial relationships between various elements or to the spatial orientation of various elements depicted in the attached drawings. In general, such relationships or orientation assume a frame of reference consistent with or relative to a patient in a position to receive treatment. However, as should be recognized by those skilled in the art, this frame of reference is merely a descriptive expedient rather than a strict prescription.

[0031] The term “tissue site” in this context broadly refers to a wound, defect, or other treatment target located on or within tissue, including but not limited to, bone tissue, adipose tissue, muscle tissue, neural tissue, dermal tissue, vascular tissue, connective tissue, cartilage, tendons, or ligaments. A wound may include chronic, acute, traumatic, subacute, and dehisced wounds, partial-thickness burns, ulcers (such as diabetic, pressure, or venous insufficiency ulcers), flaps, and grafts, for example. The term “tissue site” may also refer to areas of any tissue that are not necessarily wounded or defective but are instead areas in which it may be desirable to add or promote the growth of additional tissue. For example, negative pressure may be applied to a tissue site to grow additional tissue that may be harvested and transplanted.

[0032] The present technology also provides negative pressure therapy devices and systems, and methods of treatment using such systems with antimicrobial solutions. Figure 1 is a simplified functional block diagram of an example embodiment of a therapy system 100 that can provide negative-pressure therapy with instillation of treatment solutions in accordance with this specification. The therapy system 100 may include a negative-pressure supply, and may include or be configured to be coupled to a distribution component, such as a dressing. In general, a distribution component may refer to any complementary or ancillary component configured to be fluidly coupled to a negative-pressure supply between a negative-pressure supply and a tissue site. A distribution component is preferably detachable, and may be disposable, reusable, or recyclable. For example, a dressing 102 is illustrative of a distribution component that may be coupled to a negative-pressure source and other

components. The therapy system 100 may be packaged as a single, integrated unit such as a therapy system including all of the components shown in Figure 1 that are fluidly coupled to the dressing 102. The therapy system may be, for example, a V.A.C. Ultra™ System available from Kinetic Concepts, Inc. of San Antonio, Texas.

[0033] The dressing 102 may be fluidly coupled to a negative-pressure source 104. A dressing may include a cover, a tissue interface, or both in some embodiments. The dressing 102, for example, may include a cover 106, a dressing interface 107, and a tissue interface 108. A computer or a controller device, such as a controller 110, may also be coupled to the negative-pressure source 104. In some embodiments, the cover 106 may be configured to cover the tissue interface 108 and the tissue site and may be adapted to seal the tissue interface and create a therapeutic environment proximate to a tissue site for maintaining a negative pressure at the tissue site. In some embodiments, the dressing interface 107 may be configured to fluidly couple the negative-pressure source 104 to the therapeutic environment of the dressing. The therapy system 100 may optionally include a fluid container, such as a container 112, fluidly coupled to the dressing 102 and to the negative-pressure source 104.

[0034] The therapy system 100 may also include a source of instillation solution, such as a solution source 114. A distribution component may be fluidly coupled to a fluid path between a solution source and a tissue site in some embodiments. For example, an instillation pump 116 may be coupled to the solution source 114, as illustrated in the example embodiment of Figure 1. The instillation pump 116 may also be fluidly coupled to the negative-pressure source 104 such as, for example, by a fluid conductor 119. In some embodiments, the instillation pump 116 may be directly coupled to the negative-pressure source 104, as illustrated in Figure 1, but may be indirectly coupled to the negative-pressure source 104 through other distribution components in some embodiments. For example, in some embodiments, the instillation pump 116 may be fluidly coupled to the negative-pressure source 104 through the dressing 102. In some embodiments, the instillation pump 116 and the negative-pressure source 104 may be fluidly coupled to two different locations on the tissue interface 108 by two different dressing interfaces. For example, the negative-pressure source 104 may be fluidly coupled to the dressing interface 107 while the instillation pump 116 may be fluidly coupled to dressing interface 107 or a second dressing interface 117. In some other embodiments, the instillation pump 116 and the negative-pressure source 104 may be fluidly coupled to two different tissue interfaces by two different dressing interfaces, one dressing interface for each tissue interface (not shown).

[0035] The therapy system 100 also may include sensors to measure operating parameters and provide feedback signals to the controller 110 indicative of the operating parameters properties of fluids extracted from a tissue site. As illustrated in Figure 1, for example, the therapy system 100 may include a pressure sensor 120, an electric sensor 124, or both, coupled to the controller 110. The pressure sensor 120 may be fluidly coupled or configured to be fluidly coupled to a distribution component such as, for example, the negative-pressure source 104 either directly or indirectly through the container 112. The pressure sensor 120 may be configured to measure pressure being generated by the negative-pressure source 104, i.e., the pump pressure (PP). The electric sensor 124 also may be coupled to the negative-pressure source 104 to measure the pump pressure (PP). In some example embodiments, the electric sensor 124 may be fluidly coupled proximate the output of the output of the negative-pressure source 104 to directly measure the pump pressure (PP). In other example embodiments, the electric sensor 124 may be electrically coupled to the negative-pressure source 104 to measure the changes in the current in order to determine the pump pressure (PP).

[0036] Distribution components may be fluidly coupled to each other to provide a distribution system for transferring fluids (i.e., liquid and/or gas). For example, a distribution system may include various combinations of fluid conductors and fittings to facilitate fluid coupling. A fluid conductor generally includes any structure with one or more lumina adapted to convey a fluid between two ends, such as a tube, pipe, hose, or conduit. Typically, a fluid conductor is an elongated, cylindrical structure with some flexibility, but the geometry and rigidity may vary. Some fluid conductors may be molded into or otherwise integrally combined with other components. A fitting can be used to mechanically and fluidly couple components to each other. For example, a fitting may comprise a projection and an aperture. The projection may be configured to be inserted into a fluid conductor so that the aperture aligns with a lumen of the fluid conductor. A valve is a type of fitting that can be used to control fluid flow. For example, a check valve can be used to substantially prevent return flow. A port is another example of a fitting. A port may also have a projection, which may be threaded, flared, tapered, barbed, or otherwise configured to provide a fluid seal when coupled to a component.

[0037] In some embodiments, distribution components may also be coupled by virtue of physical proximity, being integral to a single structure, or being formed from the same piece of material. Coupling may also include mechanical, thermal, electrical, or chemical

coupling (such as a chemical bond) in some contexts. For example, a tube may mechanically and fluidly couple the dressing 102 to the container 112 in some embodiments. In general, components of the therapy system 100 may be coupled directly or indirectly. For example, the negative-pressure source 104 may be directly coupled to the controller 110 and may be indirectly coupled to the dressing interface 107 through the container 112 by conduit 126 and conduit 130, also referred to herein as negative pressure conduit 126 and negative pressure conduit 130. The pressure sensor 120 may be fluidly coupled to the dressing 102 directly (not shown) or indirectly by conduit 121 and conduit 122. Additionally, the instillation pump 116 may be coupled indirectly to the dressing interface 107 through the solution source 114 and an instillation regulator 115 by fluid conductors 132 and 133, also referred to herein as instillation conduit 132 and instillation conduit 133. The instillation regulator 115 may be electrically coupled to the controller 110 (not shown) that may be programmed along with the instillation pump 116 to deliver instillation fluid in a controlled fashion. Alternatively, the instillation pump 116 may be coupled indirectly to the second dressing interface 117 through the solution source 114 and the instillation regulator 115 by fluid conductors 132, 133 and 134.

[0038] Some embodiments of the therapy system 100 may include a solution source, such as solution source 114, without an instillation pump, such as the instillation pump 116. Instead, the solution source 114 may be fluidly coupled directly or indirectly to the dressing interface 107 and may further include the instillation regulator 115 electrically coupled to the controller 110 as described above. In operation, the negative pressure source 104 may apply negative pressure to the dressing interface 107 through the container 112 and the negative pressure conduit 130 to create a vacuum within the spaces formed by the dressing interface 107 and the tissue interface 108. The vacuum within the spaces would draw instillation fluid into the spaces for cleansing or providing therapy treatment to the tissue site. In some embodiments, the controller 110 may be programmed to modulate the instillation regulator 115 to control the flow of instillation fluid into the spaces. In another example embodiment, the therapy system 100 may include both the instillation pump 116 and the negative pressure source 104 to alternately deliver instillation fluid to the dressing interface 107 by providing a positive pressure to the solution source 114 and a negative pressure directly to the dressing interface 107, respectively. Any of the embodiments described above may be utilized to periodically clean, rinse, or hydrate the tissue site using saline along with other pH-modulating instillation fluids such as weak acidic acids.

[0039] The fluid mechanics of using a negative-pressure source to reduce pressure in another component or location, such as within a sealed therapeutic environment, can be mathematically complex. However, the basic principles of fluid mechanics applicable to negative-pressure therapy and instillation are generally well-known to those skilled in the art, and the process of reducing pressure may be described illustratively herein as “delivering,” “distributing,” or “generating” negative pressure, for example.

[0040] In general, exudates and other fluids flow toward lower pressure along a fluid path. Thus, the term “downstream” typically implies something in a fluid path relatively closer to a source of negative pressure or further away from a source of positive pressure. Conversely, the term “upstream” implies something relatively further away from a source of negative pressure or closer to a source of positive pressure. Similarly, it may be convenient to describe certain features in terms of fluid “inlet” or “outlet” in such a frame of reference. This orientation is generally presumed for purposes of describing various features and components herein. However, the fluid path may also be reversed in some applications (such as by substituting a positive-pressure source for a negative-pressure source) and this descriptive convention should not be construed as a limiting convention.

[0041] “Negative pressure” generally refers to a pressure less than a local ambient pressure, such as the ambient pressure in a local environment external to a sealed therapeutic environment provided by the dressing 102. In many cases, the local ambient pressure may also be the atmospheric pressure at which a tissue site is located. Alternatively, the pressure may be less than a hydrostatic pressure associated with tissue at the tissue site. Unless otherwise indicated, values of pressure stated herein are gauge pressures. Similarly, references to increases in negative pressure typically refer to a decrease in absolute pressure, while decreases in negative pressure typically refer to an increase in absolute pressure. While the amount and nature of negative pressure applied to a tissue site may vary according to therapeutic requirements, the pressure is generally a low vacuum, also commonly referred to as a rough vacuum, between -5 mm Hg (-667 Pa) and -500 mm Hg (-66.7 kPa). Common therapeutic ranges are between -75 mm Hg (-9.9 kPa) and -300 mm Hg (-39.9 kPa).

[0042] A negative-pressure supply, such as the negative-pressure source 104, may be a reservoir of air at a negative pressure, or may be a manual or electrically-powered device that can reduce the pressure in a sealed volume, such as a vacuum pump, a suction pump, a wall suction port available at many healthcare facilities, or a micro-pump, for example. A negative-pressure supply may be housed within or used in conjunction with other

components, such as sensors, processing units, alarm indicators, memory, databases, software, display devices, or user interfaces that further facilitate therapy. For example, in some embodiments, the negative-pressure source 104 may be combined with the controller 110 and other components into a therapy unit. A negative-pressure supply may also have one or more supply ports configured to facilitate coupling and de-coupling the negative-pressure supply to one or more distribution components.

[0043] The tissue interface 108 can be generally adapted to contact a tissue site. The tissue interface 108 may be partially or fully in contact with the tissue site. If the tissue site is a wound, for example, the tissue interface 108 may partially or completely fill the wound or may be placed over the wound. The tissue interface 108 may take many forms, and may have many sizes, shapes, or thicknesses depending on a variety of factors, such as the type of treatment being implemented or the nature and size of a tissue site. For example, the size and shape of the tissue interface 108 may be adapted to the contours of deep and irregular shaped tissue sites. Moreover, any or all of the surfaces of the tissue interface 108 may have projections or an uneven, course, or jagged profile that can induce strains and stresses on a tissue site, which can promote granulation at the tissue site.

[0044] In some embodiments, the tissue interface 108 may be a manifold such as manifold 408 shown in Figure 4. A "manifold" in this context generally includes any substance or structure providing a plurality of pathways adapted to collect or distribute fluid across a tissue site under pressure. For example, a manifold may be adapted to receive negative pressure from a source and distribute negative pressure through multiple apertures across a tissue site, which may have the effect of collecting fluid from across a tissue site and drawing the fluid toward the source. In some embodiments, the fluid path may be reversed, or a secondary fluid path may be provided to facilitate delivering fluid across a tissue site.

[0045] In some illustrative embodiments, the pathways of a manifold may be interconnected to improve distribution or collection of fluids across a tissue site. In some illustrative embodiments, a manifold may be a porous foam material having interconnected cells or pores. For example, cellular foam, open-cell foam, reticulated foam, porous tissue collections, and other porous material such as gauze or felted mat generally include pores, edges, and/or walls adapted to form interconnected fluid channels. Liquids, gels, and other foams may also include or be cured to include apertures and fluid pathways. In some embodiments, a manifold may additionally or alternatively comprise projections that form

interconnected fluid pathways. For example, a manifold may be molded to provide surface projections that define interconnected fluid pathways.

[0046] The average pore size of a foam manifold may vary according to needs of a prescribed therapy. For example, in some embodiments, the tissue interface 108 may be a foam manifold having pore sizes in a range of 400-600 microns. The tensile strength of the tissue interface 108 may also vary according to needs of a prescribed therapy. For example, the tensile strength of a foam may be increased for instillation of topical treatment solutions. In one non-limiting example, the tissue interface 108 may be an open-cell, reticulated polyurethane foam such as GranuFoam[®] dressing or VeraFlo[®] foam, both available from Kinetic Concepts, Inc. of San Antonio, Texas.

[0047] The tissue interface 108 may be either hydrophobic or hydrophilic. In an example in which the tissue interface 108 may be hydrophilic, the tissue interface 108 may also wick fluid away from a tissue site, while continuing to distribute negative pressure to the tissue site. The wicking properties of the tissue interface 108 may draw fluid away from a tissue site by capillary flow or other wicking mechanisms. An example of a hydrophilic foam is a polyvinyl alcohol, open-cell foam such as V.A.C. WhiteFoam[®] dressing available from Kinetic Concepts, Inc. of San Antonio, Texas. Other hydrophilic foams may include those made from polyether. Other foams that may exhibit hydrophilic characteristics include hydrophobic foams that have been treated or coated to provide hydrophilicity.

[0048] The tissue interface 108 may further promote granulation at a tissue site when pressure within the sealed therapeutic environment is reduced. For example, any or all of the surfaces of the tissue interface 108 may have an uneven, coarse, or jagged profile that can induce microstrains and stresses at a tissue site if negative pressure is applied through the tissue interface 108.

[0049] In some embodiments, the tissue interface 108 may be constructed from bioresorbable materials. Suitable bioresorbable materials may include, without limitation, a polymeric blend of polylactic acid (PLA) and polyglycolic acid (PGA). The polymeric blend may also include without limitation polycarbonates, polyfumarates, and caprolactones. The tissue interface 108 may further serve as a scaffold for new cell-growth, or a scaffold material may be used in conjunction with the tissue interface 108 to promote cell-growth. A scaffold is generally a substance or structure used to enhance or promote the growth of cells or formation of tissue, such as a three-dimensional porous structure that provides a template for

cell growth. Illustrative examples of scaffold materials include calcium phosphate, collagen, PLA/PGA, coral hydroxy apatites, carbonates, or processed allograft materials.

[0050] In some embodiments, the cover 106 may provide a bacterial barrier and protection from physical trauma. The cover 106 may also be constructed from a material that can reduce evaporative losses and provide a fluid seal between two components or two environments, such as between a therapeutic environment and a local external environment. The cover 106 may be, for example, an elastomeric film or membrane that can provide a seal adequate to maintain a negative pressure at a tissue site for a given negative-pressure source. The cover 106 may have a high moisture-vapor transmission rate (MVTR) in some applications. For example, the MVTR may be at least 300 g/m² per twenty-four hours in some embodiments. In some example embodiments, the cover 106 may be a polymer drape, such as a polyurethane film, that is permeable to water vapor but impermeable to liquid. Such drapes typically have a thickness in the range of 25-50 microns. For permeable materials, the permeability generally should be low enough that a desired negative pressure may be maintained. In some embodiments, the cover may be a drape such as drape 406 shown in Figure 4.

[0051] An attachment device may be used to attach the cover 106 to an attachment surface, such as undamaged epidermis, a gasket, or another cover. The attachment device may take many forms. For example, an attachment device may be a medically-acceptable, pressure-sensitive adhesive that extends about a periphery, a portion, or an entire sealing member. In some embodiments, for example, some or all of the cover 106 may be coated with an acrylic adhesive having a coating weight between 25-65 grams per square meter (g.s.m.). Thicker adhesives, or combinations of adhesives, may be applied in some embodiments to improve the seal and reduce leaks. Other example embodiments of an attachment device may include a double-sided tape, paste, hydrocolloid, hydrogel, silicone gel, or organogel.

[0052] In some embodiments, the dressing interface 107 may facilitate coupling the negative-pressure source 104 to the dressing 102. The negative pressure provided by the negative-pressure source 104 may be delivered through the conduit 130 to a negative-pressure interface, which may include an elbow portion. In one illustrative embodiment, the negative-pressure interface may be a T.R.A.C.[®] Pad or Sensa T.R.A.C.[®] Pad available from KCI of San Antonio, Texas. The negative-pressure interface enables the negative pressure to be delivered through the cover 106 and to the tissue interface 108 and the tissue site. In this

illustrative, non-limiting embodiment, the elbow portion may extend through the cover 106 to the tissue interface 108, but numerous arrangements are possible.

[0053] A controller, such as the controller 110, may be a microprocessor or computer programmed to operate one or more components of the therapy system 100, such as the negative-pressure source 104. In some embodiments, for example, the controller 110 may be a microcontroller, which generally comprises an integrated circuit containing a processor core and a memory programmed to directly or indirectly control one or more operating parameters of the therapy system 100. Operating parameters may include the power applied to the negative-pressure source 104, the pressure generated by the negative-pressure source 104, or the pressure distributed to the tissue interface 108, for example. The controller 110 is also preferably configured to receive one or more input signals, such as a feedback signal, and programmed to modify one or more operating parameters based on the input signals.

[0054] Sensors, such as the pressure sensor 120 or the electric sensor 124, are generally known in the art as any apparatus operable to detect or measure a physical phenomenon or property, and generally provide a signal indicative of the phenomenon or property that is detected or measured. For example, the pressure sensor 120 and the electric sensor 124 may be configured to measure one or more operating parameters of the therapy system 100. In some embodiments, the pressure sensor 120 may be a transducer configured to measure pressure in a pneumatic pathway and convert the measurement to a signal indicative of the pressure measured. In some embodiments, for example, the pressure sensor 120 may be a piezoresistive strain gauge. The electric sensor 124 may optionally measure operating parameters of the negative-pressure source 104, such as the voltage or current, in some embodiments. Preferably, the signals from the pressure sensor 120 and the electric sensor 124 are suitable as an input signal to the controller 110, but some signal conditioning may be appropriate in some embodiments. For example, the signal may need to be filtered or amplified before it can be processed by the controller 110. Typically, the signal is an electrical signal that is transmitted and/or received on by wire or wireless means, but may be represented in other forms, such as an optical signal.

[0055] The solution source 114 is representative of a container, canister, pouch, bag, or other storage component, which can provide a solution for instillation therapy. Compositions of solutions may vary according to a prescribed therapy, but examples of solutions that may be suitable for some prescriptions include hypochlorite-based solutions, silver nitrate (0.5%), sulfur-based solutions, biguanides, cationic solutions, and isotonic

solutions. Examples of such other therapeutic solutions that may be suitable for some prescriptions include hypochlorite-based solutions, silver nitrate (0.5%), sulfur-based solutions, biguanides, cationic solutions, and isotonic solutions. In one illustrative embodiment, the solution source 114 may include a storage component for the solution and a separate cassette for holding the storage component and delivering the solution to the tissue site 150, such as a V.A.C. VeraLink™ Cassette available from Kinetic Concepts, Inc. of San Antonio, Texas.

[0056] The container 112 may also be representative of a container, canister, pouch, or other storage component, which can be used to collect and manage exudates and other fluids withdrawn from a tissue site. In many environments, a rigid container such as, for example, a container 162, may be preferred or required for collecting, storing, and disposing of fluids. In other environments, fluids may be properly disposed of without rigid container storage, and a re-usable container could reduce waste and costs associated with negative-pressure therapy. In some embodiments, the container 112 may comprise a canister having a collection chamber, a first inlet fluidly coupled to the collection chamber and a first outlet fluidly coupled to the collection chamber and adapted to receive negative pressure from a source of negative pressure. In some embodiments, a first fluid conductor may comprise a first member such as, for example, the conduit 130 fluidly coupled between the first inlet and the tissue interface 108 by the negative-pressure interface described above, and a second member such as, for example, the conduit 126 fluidly coupled between the first outlet and a source of negative pressure whereby the first conductor is adapted to provide negative pressure within the collection chamber to the tissue site.

[0057] The therapy system 100 may also comprise a flow regulator such as, for example, a vent regulator 118 fluidly coupled to a source of ambient air to provide a controlled or managed flow of ambient air to the sealed therapeutic environment provided by the dressing 102 and ultimately the tissue site. In some embodiments, the vent regulator 118 may control the flow of ambient fluid to purge fluids and exudates from the sealed therapeutic environment. In some embodiments, the vent regulator 118 may be fluidly coupled by a fluid conductor or vent conduit 135 through the dressing interface 107 to the tissue interface 108. The vent regulator 118 may be configured to fluidly couple the tissue interface 108 to a source of ambient air as indicated by a dashed arrow. In some embodiments, the vent regulator 118 may be disposed within the therapy system 100 rather than being proximate to the dressing 102 so that the air flowing through the vent regulator

118 is less susceptible to accidental blockage during use. In such embodiments, the vent regulator 118 may be positioned proximate the container 112 and/or proximate a source of ambient air where the vent regulator 118 is less likely to be blocked during usage.

[0058] In operation, the tissue interface 108 may be placed within, over, on, or otherwise proximate a tissue site, such as tissue site 150. The cover 106 may be placed over the tissue interface 108 and sealed to an attachment surface near the tissue site 150. For example, the cover 106 may be sealed to undamaged epidermis peripheral to a tissue site. Thus, the dressing 102 can provide a sealed therapeutic environment proximate to a tissue site, substantially isolated from the external environment, and the negative-pressure source 104 can reduce the pressure in the sealed therapeutic environment. Negative pressure applied across the tissue site through the tissue interface 108 in the sealed therapeutic environment can induce macrostrain and microstrain in the tissue site, as well as remove exudates and other fluids from the tissue site, which can be collected in container 112.

[0059] In one embodiment, the controller 110 may receive and process data, such as data related to the pressure distributed to the tissue interface 108 from the pressure sensor 120. The controller 110 may also control the operation of one or more components of therapy system 100 to manage the pressure distributed to the tissue interface 108 for application to the wound at the tissue site 150, which may also be referred to as the wound pressure (WP). In one embodiment, controller 110 may include an input for receiving a desired target pressure (TP) set by a clinician or other user and may be program for processing data relating to the setting and inputting of the target pressure (TP) to be applied to the tissue site 150. In one example embodiment, the target pressure (TP) may be a fixed pressure value determined by a user/caregiver as the reduced pressure target desired for therapy at the tissue site 150 and then provided as input to the controller 110. The user may be a nurse or a doctor or other approved clinician who prescribes the desired negative pressure to which the tissue site 150 should be applied. The desired negative pressure may vary from tissue site to tissue site based on the type of tissue forming the tissue site 150, the type of injury or wound (if any), the medical condition of the patient, and the preference of the attending physician. After selecting the desired target pressure (TP), the negative-pressure source 104 is controlled to achieve the target pressure (TP) desired for application to the tissue site 150.

[0060] Referring more specifically to Figure 2A, a graph illustrating an illustrative embodiment of pressure control modes 200 that may be used for the negative-pressure and instillation therapy system of Figure 1 is shown wherein the x-axis represents time in minutes

(min) and/or seconds (sec) and the y-axis represents pressure generated by a pump in Torr (mmHg) that varies with time in a continuous pressure mode and an intermittent pressure mode that may be used for applying negative pressure in the therapy system. The target pressure (TP) may be set by the user in a continuous pressure mode as indicated by solid line 201 and dotted line 202 wherein the wound pressure (WP) is applied to the tissue site 150 until the user deactivates the negative-pressure source 104. The target pressure (TP) may also be set by the user in an intermittent pressure mode as indicated by solid lines 201, 203 and 205 wherein the wound pressure (WP) is cycled between the target pressure (TP) and atmospheric pressure. For example, the target pressure (TP) may be set by the user at a value of 125 mmHg for a specified period of time (e.g., 5 min) followed by the therapy being turned off for a specified period of time (e.g., 2 min) as indicated by the gap between the solid lines 203 and 205 by venting the tissue site 150 to the atmosphere, and then repeating the cycle by turning the therapy back on as indicated by solid line 205 which consequently forms a square wave pattern between the target pressure (TP) level and atmospheric pressure.

[0061] In some example embodiments, the decrease in the wound pressure (WP) at the tissue site 150 from ambient pressure to the target pressure (TP) is not instantaneous, but rather gradual depending on the type of therapy equipment and dressing being used for the particular therapy treatment. For example, the negative-pressure source 104 and the dressing 102 may have an initial rise time as indicated by the dashed line 207 that may vary depending on the type of dressing and therapy equipment being used. For example, the initial rise time for one therapy system may be in the range between about 20-30 mmHg/second or, more specifically, equal to about 25 mmHg/second, and in the range between about 5-10 mmHg/second for another therapy system. When the therapy system 100 is operating in the intermittent mode, the repeating rise time as indicated by the solid line 205 may be a value substantially equal to the initial rise time as indicated by the dashed line 207.

[0062] The target pressure may also be a variable target pressure (VTP) controlled or determined by controller 110 that varies in a dynamic pressure mode. For example, the variable target pressure (VTP) may vary between a maximum and minimum pressure value that may be set as an input determined by a user as the range of negative pressures desired for therapy at the tissue site 150. The variable target pressure (VTP) may also be processed and controlled by controller 110 that varies the target pressure (TP) according to a predetermined waveform such as, for example, a sine waveform or a saw-tooth waveform or a triangular

waveform, that may be set as an input by a user as the predetermined or time-varying reduced pressures desired for therapy at the tissue site 150.

[0063] Referring more specifically to Figure 2B, a graph illustrating an illustrative embodiment of another pressure control mode for the negative-pressure and instillation therapy system of Figure 1 is shown wherein the x-axis represents time in minutes (min) and/or seconds (sec) and the y-axis represents pressure generated by a pump in Torr (mmHg) that varies with time in a dynamic pressure mode that may be used for applying negative pressure in the therapy system. For example, the variable target pressure (VTP) may be a reduced pressure that provides an effective treatment by applying reduced pressure to tissue site 150 in the form of a triangular waveform varying between a minimum and maximum pressure of 50-125 mmHg with a rise time 212 set at a rate of +25 mmHg/min. and a descent time 211 set at -25 mmHg/min, respectively. In another embodiment of the therapy system 100, the variable target pressure (VTP) may be a reduced pressure that applies reduced pressure to tissue site 150 in the form of a triangular waveform varying between 25-125 mmHg with a rise time 212 set at a rate of +30 mmHg/min and a descent time 211 set at -30 mmHg/min. Again, the type of system and tissue site determines the type of reduced pressure therapy to be used.

[0064] Figure 3 is a flow chart illustrating an illustrative embodiment of a therapy method 300 that may be used for providing negative-pressure and instillation therapy for delivering an antimicrobial solution or other treatment solution to a dressing at a tissue site. In one embodiment, the controller 110 receives and processes data, such as data related to fluids provided to the tissue interface 108. Such data may include the type of instillation solution prescribed by a clinician, the volume of fluid or solution to be instilled to the tissue site (“fill volume”), and the amount of time needed to soak the tissue interface (“soak time”) before applying a negative pressure to the tissue site. The fill volume may be, for example, between 10 and 500 mL, and the soak time may be between one second to 30 minutes. The controller 110 may also control the operation of one or more components of the therapy system 100 to manage the instillation fluids delivered from the solution source 114 to the tissue site 150 for cleaning and/or providing therapy treatment to the wound along with the negative pressure therapy as described above. In one embodiment, fluid may be instilled to the tissue site 150 by applying a negative pressure from the negative-pressure source 104 to reduce the pressure at the tissue site 150 and draw the instillation fluid into the dressing 102 as indicated at 302 and described above in more detail. In another embodiment, fluid may be

instilled to the tissue site 150 by applying a positive pressure from the negative-pressure source 104 (not shown) or the instillation pump 116 to force the instillation fluid from the solution source 114 to the tissue interface 108 as indicated at 304. In yet another embodiment, fluid may be instilled to the tissue site 150 by elevating the solution source 114 to height sufficient to force the instillation fluid into the tissue interface 108 by the force of gravity as indicated at 306. Thus, the therapy method 300 includes instilling fluid into the tissue interface 108 by either drawing or forcing the fluid into the tissue interface 108 as indicated at 310.

[0065] The therapy method 300 may control the fluid dynamics of applying the fluid solution to the tissue interface 108 at 312 by providing a continuous flow of fluid at 314 or an intermittent flow of fluid for soaking the tissue interface 108 at 316. The therapy method 300 may include the application of negative pressure to the tissue interface 108 to provide either the continuous flow or intermittent soaking flow of fluid at 320. The application of negative pressure may be implemented to provide a continuous pressure mode of operation at 322 as described above to achieve a continuous flow rate of instillation fluid through the tissue interface 108 or a dynamic pressure mode of operation at 324 as described above to vary the flow rate of instillation fluid through the tissue interface 108. Alternatively, the application of negative pressure may be implemented to provide an intermittent mode of operation at 326 as described above to allow instillation fluid to soak into the tissue interface 108 as described above. In the intermittent mode, a specific fill volume and the soak time may be provided depending, for example, on the type of wound being treated and the type of dressing 102 being utilized to treat the wound. After or during instillation of fluid into the tissue interface 108 has been completed, the therapy method 300 may begin may be utilized using any one of the three modes of operation at 330 as described above. The controller 110 may be utilized to select any one of these three modes of operation and the duration of the negative pressure therapy as described above before commencing another instillation cycle at 340 by instilling more fluid at 310.

[0066] As discussed above, the tissue site 150 may include, without limitation, any irregularity with a tissue, such as an open wound, surgical incision, or diseased tissue. The therapy system 100 is presented in the context of a tissue site that includes a wound that may extend through the epidermis and the dermis and may reach into the hypodermis or subcutaneous tissue. The therapy system 100 may be used to treat a wound of any depth, as well as many different types of wounds including open wounds, incisions, or other tissue

sites. The tissue site 150 may be the bodily tissue of any human, animal, or other organism, including bone tissue, adipose tissue, muscle tissue, dermal tissue, vascular tissue, connective tissue, cartilage, tendons, ligaments, or any other tissue. Treatment of the tissue site 150 may include removal of fluids originating from the tissue site 150, such as exudates or ascites, or fluids instilled into the dressing to cleanse or treat the tissue site 150, such as antimicrobial solutions.

[0067] As indicated above, the therapy system 100 may be packaged as a single, integrated unit such as a therapy system including all of the components shown in Figure 1 that are fluidly coupled to the dressing 102. In some embodiments, an integrated therapy unit may include the negative-pressure source 104, the controller 110, the pressure sensor 120, and the container 112 which may be fluidly coupled to the dressing interface 107. In this therapy unit, the negative-pressure source 104 is indirectly coupled to the dressing interface 107 through the container 112 by conduit 126 and conduit 130, and the pressure sensor 120 is indirectly coupled to the dressing interface 107 by conduit 121 and conduit 122 as described above. In some embodiments, the negative pressure conduit 130 and the pressure sensing conduit 122 may be combined in a single fluid conductor that can be, for example, a multi-lumen tubing comprising a central primary lumen that functions as the negative pressure conduit 130 for delivering negative pressure to the dressing interface 107 and several peripheral auxiliary lumens that function as the pressure sensing conduit 122 for sensing the pressure that the dressing interface 107 delivers to the tissue interface 108. In this type of therapy unit wherein the pressure sensor 120 is removed from and indirectly coupled to the dressing interface 107, the negative pressure measured by the pressure sensor 120 may be different from the wound pressure (WP) actually being applied to the tissue site 150. Such pressure differences must be approximated in order to adjust the negative-pressure source 104 to deliver the pump pressure (PP) necessary to provide the desired or target pressure (TP) to the tissue interface 108. Moreover, such pressure differences and predictability may be exacerbated by viscous fluids such as exudates being produced by the tissue site or utilizing a single therapy device including a pressure sensor to deliver negative pressure to multiple tissue sites on a single patient.

[0068] What is needed is a pressure sensor that is integrated within the dressing interface 107 so that the pressure sensor is proximate the tissue interface 108 when disposed on the tissue site in order to provide a more accurate reading of the wound pressure (WP) being provided within the therapy environment of the dressing 102. The integrated pressure

sensor may be used with or without the remote pressure sensor 120 that is indirectly coupled to the dressing interface 107. In some example embodiments, the dressing interface 107 may comprise a housing having a therapy cavity that opens to the tissue site when positioned thereon. The integrated pressure sensor may have a sensing portion disposed within the therapy cavity along with other sensors including, for example, a temperature sensor, a humidity sensor, and a pH sensor. The sensors may be electrically coupled to the controller 110 outside the therapy cavity to provide data indicative of the pressure, temperature, humidity, and acidity properties within the therapeutic space of the therapy cavity. The sensors may be electrically coupled to the controller 110, for example, by wireless means. Systems, apparatuses, and methods described herein provide the advantage of more accurate measurements of these properties, as well as other significant advantages described below in more detail.

[0069] As indicated above, the dressing 102 may include the cover 106, the dressing interface 107, and the tissue interface 108. Referring now to Figures 4, 5A, 5B, 5C, 6A, 6B, and 7, a first dressing is shown comprising a dressing interface 400, a cover or drape 406, and a tissue interface or manifold 408 disposed adjacent a tissue site 410, all of which may be functionally similar in part to the dressing interface 107, the cover 106, and the tissue interface 108, respectively, as described above. In one example embodiment, the dressing interface 400 may comprise a housing 401 and a wall 402 disposed within the housing 401 wherein the wall 402 forms a recessed space or a therapy cavity 403 that opens to the manifold 408 when disposed at the tissue site 410 and a component cavity 404 opening away from the tissue site 410 of the upper portion of the dressing interface 400. In some embodiments, sensing portions of various sensors may be disposed within the therapy cavity 403, and electrical devices associated with the sensors may be disposed within the component cavity 404 and electrically coupled to the sensing portions through the wall 402. Electrical devices disposed within the component cavity 404 may include components associated with some example embodiments of the therapy system of Figure 1. Although the dressing interface 400 and the therapy cavity 403 are functionally similar to the dressing interface 107 as described above, the dressing interface 400 further comprises the wall 402, the sensors, and the associated electrical devices described below in more detail. In some embodiments, the housing 401 may further comprise a neck portion or neck 407 fluidly coupled to a conduit 405. In some embodiments, the housing 401 may further comprise a flange portion or flange

409 having flow channels (see Figure 8) configured to be fluidly coupled to the therapy cavity 403 when disposed on the manifold 408.

[0070] In some example embodiments, the neck 407 of the housing 401 may include portions of both the therapy cavity 403 and the component cavity 404. That portion of the neck 407 extending into the therapy cavity 403 is fluidly coupled to the conduit 405, while the portion extending into the component cavity 404 may contain some of the electrical devices. In some example embodiments, the conduit 405 may comprise a primary lumen or a negative pressure lumen 430 and separate auxiliary lumens such as, for example, an instillation lumen 433 and a venting lumen 435 fluidly coupled by the neck 407 of the housing 401 to the therapy cavity 403. The negative pressure lumen 430 is similar to the negative pressure conduit 130 that may be coupled indirectly to the negative-pressure source 104. The venting lumen 435 is similar to the vent conduit 135 that may be fluidly coupled to the vent regulator 118 for purging fluids from the therapy cavity 403. The instillation lumen 433 is similar to the instillation conduit 133 that may be fluidly coupled directly or indirectly to the solution source 114 for flushing fluids from the therapy cavity 403 for removal by the application of negative pressure through the negative pressure lumen 430.

[0071] In some embodiments, the component cavity 404 containing the electrical devices may be open to the ambient environment such that the electrical devices are exposed to the ambient environment. In other example embodiments, the component cavity 404 may be closed by a cover such as, for example, a cap 411 to protect the electrical devices. In still other embodiments, the component cavity 404 covered by the cap 411 may still be vented to the ambient environment to provide cooling to the electrical devices and a source of ambient pressure for a pressure sensor disposed in the therapy cavity 403 as described in more detail below. The first dressing interface 400 may further comprise a drape ring 413 covering the circumference of the flange 409 and the adjacent portion of the drape 406 to seal the therapy cavity 403 of the housing 401 over the manifold 408 and the tissue site 410. In some embodiments, the drape ring 413 may comprise a polyurethane film including and an attachment device such as, for example, an acrylic, polyurethane gel, silicone, or hybrid combination of the foregoing adhesives (not shown) to attach the drape ring 413 to the flange 409 and the drape 406. The attachment device of drape ring 413 may be a single element of silicon or hydrocolloid with the adhesive on each side that functions as a gasket between the drape 406 and the flange 409. In some embodiments, the drape ring 413 may be similar to the cover 106 and/or the attachment device described above in more detail.

[0072] In some embodiments, a pressure sensor 416, a temperature and humidity sensor 418, and a pH sensor 420 (collectively referred to below as “the sensors”) may be disposed in the housing 401 with each one having a sensing portion extending into the therapy cavity 403 of the housing 401 and associated electronics disposed within the component cavity 404. The housing 401 may include other types of sensors, or combinations of the foregoing sensors, such as, for example, oxygen sensors. In some example embodiments, the sensors may be coupled to or mounted on the wall 402 and electrically coupled to electrical components and circuits disposed within the component cavity 404 by electrical conductors extending through the wall 402. In some preferred embodiments, the electrical conductors extend through pathways in the wall 402 while keeping the therapy cavity 403 electrically and pneumatically isolated from the component cavity 404. For example, the wall 402 may comprise a circuit board 432 on which the electrical circuits and/or components may be printed or mounted. In some other examples, the circuit board 432 may be the wall 402 that covers an opening between the therapy cavity 403 and the component cavity 404, and pneumatically seals the therapy cavity 403 from the component cavity 404 when seated over the opening.

[0073] In some embodiments, the electrical circuits and/or components associated with the sensors that are mounted on the circuit board 432 within the component cavity 404 may be electrically coupled to the controller 110 to interface with the rest of the therapy system 100 as described above. In some embodiments, for example, the electrical circuits and/or components may be electrically coupled to the controller 110 by a conductor that may be a component of the conduit 405. In some other preferred embodiments, a communications module 422 may be disposed in the component cavity 404 of the housing 401 and mounted on the circuit board 432 within the component cavity 404. Using a wireless communications module 422 has the advantage of eliminating an electrical conductor between the dressing interface 400 and the integrated portion of the therapy system 100 that may become entangled with the conduit 405 when in use during therapy treatments. For example, the electrical circuits and/or components associated with the sensors along with the terminal portion of the sensors may be electrically coupled to the controller 110 by wireless means such as an integrated device implementing Bluetooth[®] Low Energy wireless technology. More specifically, the communications module 422 may be a Bluetooth[®] Low Energy system-on-chip that includes a microprocessor (an example of the microprocessors referred to hereinafter) such as the nRF51822 chip available from Nordic Semiconductor. The wireless

communications module 422 may be implemented with other wireless technologies suitable for use in the medical environment.

[0074] In some embodiments, a voltage regulator 423 for signal conditioning and a power source 424 may be disposed within the component cavity 404 of the housing 401 and mounted on the circuit board 432. The power supply 424 may be secured to the circuit board 432 by a bracket 426. The power source 424 may be, for example, a battery that may be a coin battery having a low-profile that provides a 3-volt source for the communications module 422 and the other electronic components within the component cavity 404 associated with the sensors. In some example embodiments, the sensors, the electrical circuits and/or components associated with the sensors, the wall 402 and/or the circuit board 432, the communications module 422, and the power source 424 may be integrated into a single package and referred to hereinafter as a sensor assembly 425 as shown in Figure 6B. In some preferred embodiments, the wall 402 of the sensor assembly 425 may be the circuit board 432 itself as described above that provides a seal between tissue site 410 and the atmosphere when positioned over the opening between the therapy cavity 403 and the component cavity 404 of the housing 401 and functions as the wall 402 within the housing 401 that forms the therapy cavity 403.

[0075] Referring now to Figures 8A and 8B, a perspective view and a bottom view, respectively, of a bottom surface of the flange 409 facing the manifold 408 is shown. In some embodiments, the bottom surface may comprise features or channels to direct the flow of liquids and/or exudates away from the sensors out of the therapy cavity 403 into the negative pressure lumen 430 when negative pressure is being applied to the therapy cavity 403. In some embodiments, these channels may be molded into the bottom surface of the flange 409 to form a plurality of serrated guide channels 437, perimeter collection channels 438, and intermediate collection channels 439. The serrated guide channels 437 may be positioned and oriented in groups on bottom surface to directly capture and channel at least half of the liquids being drawn into the therapy cavity 403 with the groups of serrated guide channels 437, and indirectly channel a major portion of the balance of the liquids being drawn into the therapy cavity 403 between the groups of serrated guide channels 437. In addition, perimeter collection channels 438 and intermediate collection channels 439 redirect the flow of liquids that are being drawn in between the groups of radially-oriented serrated guide channels 437 into the guide channels 437. An example of this redirected flow is illustrated by bolded flow arrows 436. In some example embodiments, a portion of the housing 401 within the therapy

cavity 403 may comprise a second set of serrated guide channels 427 spaced apart and radially-oriented to funnel liquids being drawn into the therapy cavity 403 from the flange 409 into the negative pressure lumen 430. In other example embodiments of the bottom surface of the flange 409 and that portion of the housing 401 within the therapy cavity 403, the channels may be arranged in different patterns.

[0076] As indicated above, the sensor assembly 425 may comprise a pressure sensor 416, a humidity sensor 418, a temperature sensor as a component of either the pressure sensor 416 or the humidity sensor 418, and a pH sensor 420. Each of the sensors may comprise a sensing portion extending into the therapy cavity 403 of the housing 401 and a terminal portion electrically coupled to the electrical circuits and/or components within the component cavity 404. Referring more specifically to Figures 4, 6A, 6B, and 7A-7D, the housing 401 may comprise a sensor bracket 441 that may be a molded portion of the housing 401 within the therapy cavity 403 in some embodiments. The sensor bracket 441 may be structured to house and secure the pressure sensor 416 on the circuit board 432 within the therapy cavity 403 of the sensor assembly 425 that provides a seal between tissue site 410 and the atmosphere as described above. In some embodiments, the pressure sensor 416 may be a differential gauge comprising a sensing portion 442 and a terminal portion or vent 443. The vent 443 of the pressure sensor 416 may be fluidly coupled through the circuit board 432 to the component cavity 404 and the atmosphere by a vent hole 444 extending through the circuit board 432. Because the component cavity 404 is vented to the ambient environment, the vent 443 of the pressure sensor 416 is able to measure the wound pressure (WP) with reference to the ambient pressure. The sensing portion 442 of the pressure sensor 416 may be positioned in close proximity to the manifold 408 to optimize fluid coupling and accurately measure the wound pressure (WP) at the tissue site 410. In some embodiments, the pressure sensor 416 may be a piezo-resistive pressure sensor having a pressure sensing element covered by a dielectric gel such as, for example, a Model 1620 pressure sensor available from TE Connectivity. The dielectric gel provides electrical and fluid isolation from the blood and wound exudates in order to protect the sensing element from corrosion or other degradation. This allows the pressure sensor 416 to measure the wound pressure (WP) directly within the therapy cavity 403 of the housing 401 proximate to the manifold 408 as opposed to measuring the wound pressure (WP) from a remote location. In some embodiments, the pressure sensor 416 may be a gauge that measures the absolute pressure that does not need to be vented.

[0077] In some embodiments, the pressure sensor 416 also may comprise a temperature sensor for measuring the temperature at the tissue site 410. In other embodiments, the humidity sensor 418 may comprise a temperature sensor for measuring the temperature at the tissue site 410. The sensor bracket 441 also may be structured to support the humidity sensor 418 on the circuit board 432 of the sensor assembly 425. In some embodiments, the humidity sensor 418 may comprise a sensing portion that is electrically coupled through the circuit board 432 to a microprocessor mounted on the other side of the circuit board 432 within the component cavity 404. The sensing portion of the humidity sensor 418 may be fluidly coupled to the space within the therapy cavity 403 that includes a fluid pathway 445 extending from the therapy cavity 403 into the negative pressure lumen 430 of the conduit 405 as indicated by the bold arrow to sense both the humidity and the temperature. The sensing portion of the humidity sensor 418 may be positioned within the fluid pathway 445 to limit direct contact with bodily fluids being drawn into the negative pressure lumen 430 from the tissue site 410. In some embodiments, the space within the therapy cavity 403 adjacent the sensing portion of the humidity sensor 418 may be purged by venting the space through the venting lumen 435 as described in more detail below. The space may also be flushed by instilling fluids into the space through the instillation lumen 433. As indicated above, the humidity sensor 418 may further comprise a temperature sensor (not shown) as the location within the fluid pathway 445 is well-suited to achieve accurate readings of the temperature of the fluids. In some embodiments, the humidity sensor 418 that comprises a temperature sensor may be a single integrated device such as, for example, Model HTU28 humidity sensor also available from TE Connectivity.

[0078] Referring now to Figures 9A and 9B, the pH sensor 420 may comprise a sensing portion disposed within the therapy cavity 403 that is electrically coupled through the circuit board 432 to a front-end amplifier 421 mounted on the other side of the circuit board 432 within the component cavity 404. The front-end amplifier 421 comprises analog signal conditioning circuitry that includes sensitive analog amplifiers such as, for example, operational amplifiers, filters, and application-specific integrated circuits. The front-end amplifier 421 measures minute voltage potential changes provided by the sensing portions to provide an output signal indicative of the pH of the fluids. The sensing portion of the pH sensor 420 may be fluidly coupled to the space within the therapy cavity 403 by being positioned in the fluid pathway 445 that extends into the negative pressure lumen 430 as described above to sense the pH changes. The sensing portion of the pH sensor 420 may be

formed and positioned within the fluid pathway 445 so that the sensing portion directly contacts the wound fluid without contacting the wound itself so that the sensing portion of the pH sensor 420 does not interfere with the wound healing process. In some embodiments, the space within the therapy cavity 403 adjacent the sensing portion of the pH sensor 420 also may be purged by venting the space through the venting lumen 435 as described in more detail below. The space may also be flushed by instilling fluids into the space through the instillation lumen 433. In some embodiments, the pH sensor 420 may be, for example, pH sensor 450 shown in Figure 9A that comprises a pair of printed medical electrodes including a working electrode 451 and a reference electrode 452. In some embodiments, the working electrode 451 may have a node being substantially circular in shape at one end and having a terminal portion at the other end, and the reference electrode 452 may have a node being substantially semicircular in shape and disposed around the node of the working electrode 451.

[0079] In some example embodiments, the working electrode 451 may comprise a material selected from a group including graphene oxide ink, conductive carbon, carbon nanotube inks, silver, nano-silver, silver chloride ink, gold, nano-gold, gold-based ink, metal oxides, conductive polymers, or a combination thereof. This working electrode 451 further comprise a coating or film applied over the material wherein such coating or film may be selected from a group including metal oxides such as, for example, tungsten, platinum, iridium, ruthenium, and antimony oxides, or a group of conductive polymers such as polyaniline and others so that the conductivity of the working electrode 451 changes based on changes in hydrogen ion concentration of the fluids being measured or sampled. In some example embodiments, the reference electrode 452 may comprise a material selected from a group including silver, nano-silver, silver chloride ink, or a combination thereof. The pH sensor 450 may further comprise a coating 453 covering the electrodes that insulates and isolates the working electrode 451 from the reference electrode 452 and the wound fluid, except for an electrical coupling space 454 between the nodes of the working electrode 451 and the reference electrode 452. The coating 453 does not cover the terminal portions of the working electrode 451 and the reference electrode 452 to form terminals 455 and 456, respectively, adapted to be electrically coupled to the front-end amplifier 421.

[0080] In some example embodiments, the terminal portion of the working electrode 451 and the reference electrode 452 may extend through the circuit board 432 and electrically coupled to the front-end amplifier 421 of the pH sensor 450. As indicated above, the front-

end amplifier 421 of the pH sensor 450 measures minute potential changes between the working electrode 451 and the reference electrode 452 that result from a change in hydrogen ion concentration of the wound fluid as the pH of the wound fluid changes. The front-end amplifier 421 may be, for example, an extremely accurate voltmeter that measures the voltage potential between the working electrode 451 and the reference electrode 452. The front-end amplifier 421 may be for example a high impedance analog front-end (AFE) device such as the LMP7721 and LMP91200 chips that are available from manufacturers such as Texas Instruments or the AD7793 and AD8603 chips that are available from manufacturers such as Analog Devices.

[0081] In some other embodiments, the pH sensor 420 may include a third electrode such as, for example, pH sensor 460 shown in Figure 9B that comprises a third electrode or a counter electrode 462 in addition to the working electrode 451 and the reference electrode 452 of the pH sensor 450. The counter electrode 462 also comprises a node partially surrounding the node of the working electrode 451 and a terminal 466 adapted to be electrically coupled to the front-end amplifier 421. Otherwise, the pH sensor 460 is substantially similar to the pH sensor 450 described above as indicated by the reference numerals. The counter electrode 462 is also separated from the working electrode 451 and is also insulated from the wound fluid and the other electrodes by the coating 453 except in the electrical conductive space 454. The counter electrode 462 may be used in connection with the working electrode 451 and the reference electrode 452 for the purpose of error correction of the voltages being measured. For example, the counter electrode 462 may possess the same voltage potential as the potential of the working electrode 451 except with an opposite sign so that any electrochemical process affecting the working electrode 451 will be accompanied by an opposite electrochemical process on the counter electrode 462. Although voltage measurements are still being taken between the working electrode 451 and the reference electrode 452 by the analog front-end device of the pH sensor 460, the counter electrode 462 may be used for such error correction and may also be used for current readings associated with the voltage measurements. Custom printed electrodes assembled in conjunction with a front-end amplifier may be used to partially comprise pH sensors such as the pH sensor 450 and the pH sensor 460 may be available from several companies such as, for example, GSI Technologies, Inc. and Dropsens.

[0082] The systems, apparatuses, and methods described herein may provide other significant advantages. For example, some therapy systems are a closed system wherein the

pneumatic pathway is not vented to ambient air, but rather controlled by varying the supply pressure (SP) to achieve the desired target pressure (TP) in a continuous pressure mode, an intermittent pressure mode, or a variable target pressure mode as described above in more detail with reference to Figures 2A and 2B. In some embodiments of the closed system, the wound pressure (WP) being measured in the dressing interface 107 may not drop in response to a decrease in the supply pressure (SP) as a result of a blockage within the dressing interface 107 or other portions of the pneumatic pathway. In some embodiments of the closed system, the supply pressure (SP) may not provide airflow to the tissue interface 108 frequently enough that may result in the creation of a significant head pressure or blockages within the dressing interface 107 that also would interfere with sensor measurements being taken by the dressing interface 400 as described above. The head pressure in some embodiments may be defined as a difference in pressure (DP) between a negative pressure set by a user or caregiver for treatment, i.e., the target pressure (TP), and the negative pressure provided by a negative pressure source that is necessary to offset the pressure drop inherent in the fluid conductors, i.e., the supply pressure (SP), in order to achieve or reach the target pressure (TP). For example, the head pressure that a negative pressure source needs to overcome may be as much as 75 mmHg. Problems may occur in such closed systems when a blockage occurs in the pneumatic pathway of the fluid conductors that causes the negative pressure source to increase to a value above the normal supply pressure (SP) as a result of the blockage. For example, if the blockage suddenly clears, the instantaneous change in the pressure being supplied may cause harm to the tissue site.

[0083] Some therapy systems have attempted to compensate for head pressure by introducing a supply of ambient air flow into the therapeutic environment, e.g., the therapy cavity 403, by providing a vent with a filter on the housing 401 of the dressing interface 400 to provide ambient air flow into the therapeutic environment as a controlled leak. However, in some embodiments, the filter may be blocked when the interface dressing is applied to the tissue site or when asked at least blocked during use. Locating the filter in such a location may also be problematic because it is more likely to be contaminated or compromised by other chemicals and agents associated with treatment utilizing instillation fluids that could adversely affect the performance of the filter and the vent itself.

[0084] The embodiments of the therapy systems described herein overcome the problems associated with having a large head pressure in a closed pneumatic environment, and the problems associated with using a vent disposed on or adjacent the dressing interface.

More specifically, the embodiments of the therapy systems described above comprise a pressure sensor, such as the pressure sensor 416, disposed within the pneumatic environment, i.e., *in situ*, that independently measures the wound pressure (WP) within the therapy cavity 403 of the housing 401 as described above rather than doing so remotely. Consequently, the pressure sensor 416 is able to instantaneously identify dangerously high head pressures and/or blockages within the therapy cavity 403 adjacent the manifold 408. Because the auxiliary lumens are not being used for pressure sensing, the venting lumen 435 may be fluidly coupled to a fluid regulator such as, for example, the vent regulator 118 in Figure 1, that may remotely vent the therapeutic environment within the therapy cavity 403 to the ambient environment or fluidly couple the therapeutic environment to a source of positive pressure. The vent regulator 118 may then be used to provide ambient air or positive pressure to the therapeutic environment in a controlled fashion to “purge” the therapeutic environment within both the therapy cavity 403 and the negative pressure lumen 430 to resolve the problems identified above regarding head pressures and blockages, and to facilitate the continuation of temperature, humidity, and pH measurements as described above.

[0085] Using a regulator to purge the therapeutic environment is especially important in therapy systems such as those disclosed in Figures 1 and 3 that provide both negative pressure therapy and instillation therapy for delivering therapeutic fluids to a tissue site. For example, in one embodiment, therapeutic fluid may be instilled to the tissue site 150 by applying a negative pressure from the negative-pressure source 104 to reduce the pressure at the tissue site 150 to draw the therapeutic fluid into the dressing 102 as indicated at 302. In another embodiment, therapeutic fluid may be instilled to the tissue site 150 by applying a positive pressure from the negative-pressure source 104 (not shown) or the instillation pump 116 to force the therapeutic fluid from the solution source 114 to the tissue interface 108 as indicated at 304. Such embodiments may not be sufficient to remove all the therapeutic fluid from the therapeutic environment, or may not be sufficient to remove the therapeutic fluid quickly enough from the therapeutic environment to facilitate the continuation of accurate temperature, humidity, and pH measurements. Thus, the venting lumen 435 may be used to provide ambient air or positive pressure to the therapeutic environment to more completely or quickly purge the therapeutic environment to obtain the desired measurements as described above.

[0086] In embodiments of therapy systems that include an air flow regulator comprising a valve such as the solenoid valve described above, the valve provides controlled

airflow venting or positive pressure to the therapy cavity 403 as opposed to a constant airflow provided by a closed system or an open system including a filter in response to the wound pressure (WP) being sensed by the pressure sensor 416. The controller 110 may be programmed to periodically open the solenoid valve as described above allowing ambient air to flow into the therapy cavity 403, or applying a positive pressure into the therapy cavity 403, at a predetermined flow rate and/or for a predetermined duration of time to purge the pneumatic system including the therapy cavity 403 and the negative pressure lumen 430 of bodily liquids and exudates so that the humidity sensor 418 and the pH sensor 420 provide more accurate readings and in a timely fashion. This feature allows the controller to activate the solenoid valve in a predetermined fashion to purge blockages and excess liquids that may develop in the fluid pathways or the therapy cavity 403 during operation. In some embodiments, the controller may be programmed to open the solenoid valve for a fixed period of time at predetermined intervals such as, for example, for five seconds every four minutes to mitigate the formation of any blockages.

[0087] In some other embodiments, the controller may be programmed to open the solenoid valve in response to a stimulus within the pneumatic system rather than, or additionally, being programmed to function on a predetermined therapy schedule. For example, if the pressure sensor is not detecting pressure decay in the canister, this may be indicative of a column of fluid forming in the fluid pathway or the presence of a blockage in the fluid pathway. Likewise, the controller may be programmed to recognize that an expected drop in canister pressure as a result of the valve opening may be an indication that the fluid pathway is open. The controller may be programmed to conduct such tests automatically and routinely during therapy so that the patient or caregiver can be forewarned of an impending blockage. The controller may also be programmed to detect a relation between the extent of the deviation in canister pressure resulting from the opening of the valve and the volume of fluid within the fluid pathway. For example, if the pressure change within the canister is significant when measured, this could be an indication that there is a significant volume of fluid within the fluid pathway. However, if the pressure change within the canister is not significant, this could be an indication that the plenum volume was larger.

[0088] The systems, apparatuses, and methods described herein may provide additional advantages related to the instillation of cleansing and/or therapeutic solutions to the therapy cavity 403. Using a source of fluids such as, for example, solution source 114 to flush the therapeutic environment is especially important in therapy systems such as those

disclosed in Figures 1 and 3 that provide both negative pressure therapy and instillation therapy for delivering therapeutic fluids to a tissue site. For example, the sensors are disposed within the therapy cavity 403 and consequently exposed and in direct conflict with wound fluids and exudates that have the potential for fouling the sensors so that they do not provide reliable data over a period of time during which therapy is being provided. Moreover, fouling the sensors may also disable the sensors and/or degrade the calibration of the sensors such that they no longer accurately analyze the wound fluid to provide data indicating the current state of the wound. Additionally, some of the sensors such as, for example, the pH sensor 420 comprising screen-printed electrodes as described above require soaking or hydration to ensure stable measurement of the potential difference between the electrodes, i.e., the voltage between the working and the reference electrodes. Manual cleaning or hydration (lavage) of the sensors would not work because the therapeutic cavity would not be conveniently accessible as it would require the removal of the dressing to provide sufficient access to the tissue interface 108. Thus, the ability to provide cleansing and/or therapeutic solutions directly to the therapy cavity 403 for cleansing or hydration as described above along with the ability to deliver negative pressure and other pH-modulating controlled instillates such as phosphate buffered saline or weak acidic acids is a distinct advantage to enhance operation of the systems and methods described herein.

[0089] As described above in more detail, some embodiments of the therapy system 100 may include a solution source, such as solution source 114, without an instillation pump, such as the instillation pump 116. Instead, the solution source 114 may be fluidly coupled directly or indirectly to the dressing interface 400 and may further include the instillation regulator 115 electrically coupled to the controller 110 as described above. In operation, the negative pressure source 104 may apply negative pressure to the therapy cavity 403 through the container 112 and the negative pressure lumen 430 to create a vacuum within the space formed by the therapy cavity 403 and the tissue interface 108. The vacuum within the space would draw cleansing and/or hydration fluid from the solution source 114 and through the instillation lumen 433 into the space for cleansing or wetting the sensors and/or the tissue interface 108. In some embodiments, the controller 110 may be programmed to modulate the instillation regulator 115 to control the flow of such fluids into the space. Any of the embodiments described above may be utilized to periodically clean, rinse, or hydrate the sensors, the tissue interface, and the tissue site using saline along with other pH-modulating instillation fluids such as weak acidic acids.

[0090] As indicated above, the dressing 102 may include the cover 106, the dressing interface 107, and the tissue interface 108. Referring now to Figures 10A and 10B, a second dressing is shown comprising a dressing interface 500 that may be substantially similar to the first dressing interface 400 as indicated in part by the last two digits of the reference numerals identifying various components of the second dressing interface 500 as antecedent basis if not described differently below. The second dressing interface 500 may be a lower profile embodiment of the first dressing interface 400 because the second dressing interface 500 does not include a neck portion similar to the neck 407 that angles upwardly away from the tissue site 410. Eliminating the neck portion allows the conduit 405 to be coupled to the second dressing interface 500 parallel to the tissue site 410. Otherwise, like the first dressing interface 400, the dressing interface 500 may comprise a housing 501 and a wall 502 disposed within the housing 501 wherein the wall 502 forms a therapy cavity 503 that opens to the manifold 408 when disposed at the tissue site 410 and a component cavity 504 opening away from the tissue site 410 of the upper portion of the dressing interface 500. In some embodiments, sensing portions of various sensors may be disposed within the therapy cavity 503, and electrical devices associated with the sensors may be disposed within the component cavity 504 and electrically coupled to the sensing portions through the wall 502. Electrical devices disposed within the component cavity 504 may include components associated with some example embodiments of the therapy system of Figure 1 as described above. The dressing interface 500 further comprises the sensor assembly 525 including all of the sensors and the associated electrical devices that have been described in more detail above with respect to the first dressing interface 400 as indicated by the reference numerals.

[0091] In some embodiments, the second dressing interface 500 may differ further from the first dressing interface 400. For example, the housing 501 may comprise several pieces including a housing body 570 having walls that may have a generally cylindrical shape including a proximal wall section 571 and a distal wall section 572. The proximal wall section 571 may comprise a proximal bracket 573 and the distal wall section 572 may comprise a distal bracket 574 that support the sensor assembly 525. The second dressing interface 500 may differ further from the first dressing interface 400 because it may comprise two separate ports to accommodate two separate conduits, conduit 505 and conduit 555, rather than a single conduit 405 that includes a primary and auxiliary lumen. In some embodiments, the conduit 505 may include a negative pressure lumen 530 fluidly coupled to the negative pressure source 104 through the container 112 for delivering negative pressure to

the therapy cavity 503 as indicated by arrow 531. In some embodiments, the conduit 555 may include and an instillation lumen 533 fluidly coupled to the instillation source 114 for delivery of cleansing and/or instillation fluids as indicated by arrow 534. The proximal wall section 571 may further comprise a port 576 configured to be fluidly coupled to the negative pressure lumen 530 of the conduit 505, and a port 577 configured to be fluidly coupled to the instillation lumen 533 of the conduit 555. In some embodiments, each piece of the housing 501 may further comprise a portion of the flange 509.

[0092] The second dressing interface 500 may differ further from the first dressing interface 400 because the housing 501 may further comprise shaped features or baffles disposed within the therapy cavity 503 and operatively disposed adjacent the port 576 and the port 577 to direct the flow of the instillation fluids on fluid delivery and removal pathways to adequately clean and/or hydrate the sensors as described in more detail above. In some embodiments, the housing 501 may further comprise directional baffles 581 and 583 extending from the wall of the proximal wall section 571 towards the distal wall section 572 on either side of the of the ports to direct the flow of fluids along the fluid delivery and removal pathways under both vacuum and instillation conditions such that the sensors are exposed to the flow of fluids. In some embodiments, the housing 501 may further comprise a separation baffle 585 extending from the wall of the proximal wall section 571 towards the distal wall section 572 and between the of the ports to separate the initial delivery of fluid adjacent the port 577 from the final removal of fluid adjacent the port 576 so that the flow of fluid reaches the sensors rather than being prematurely drained form the therapy cavity 503. For example, this embodiment is effective to adequately hydrate the pH sensor 520 to ensure that the pH sensor 520 is always exposed to the flow of fluids and that the pH sensor 520 can be pre-soaked to immediately measure the acidity of fluids from the tissue site.

[0093] Referring to Figure 11, another example embodiment of the dressing interface 500 is shown that differs from the embodiment shown in Figures 10A and 10B because the dressing interface 500 comprises a third port to accommodate a conduit having a venting lumen that may be fluidly coupled to the vent regulator 118 for purging fluids from the therapy cavity 403. In some embodiments, the conduit may be separate from the conduit 505 and the conduit 555 and fluidly coupled to the third port. In other embodiments, the conduit may be configured in a side-by-side configuration with either one, or both, of the other two conduits. In yet other embodiments, the conduit may be configured with two lumens that include the venting lumen and either one, or both, of the other two lumens. For example, a

conduit 655 has a venting lumen 633 and is configured in a side-by-side configuration with negative pressure conduit 505. The venting lumen 633 may be fluidly coupled to a third port 678 that extends through the proximal wall section 571. In some embodiments, the third port 678 may extend through the baffle 581 so that the third port 678 opens closer to the distal wall section 572 to enhance the removal of fluids from the therapy cavity 503 as described in more detail above. In some embodiments, the port 678 may comprise a separate conduit extending from the proximal wall section 571 toward the wall of the distal wall section 572. In operation, the venting lumen 633 is similar to the vent conduit 135 that may be fluidly coupled to the vent regulator 118 for purging fluids from the therapy cavity 503 as indicated by arrow 636. The instillation lumen 533 may be fluidly coupled to the instillation source 114 for delivery of cleansing and/or instillation fluids to the therapy cavity 503 as indicated by arrow 534. The port 577 may be configured to be fluidly coupled to the instillation lumen 533 of the conduit 555. The instillation lumen 533 is similar to the instillation conduit 133 that may be fluidly coupled directly or indirectly to the solution source 114 for flushing and removing fluids from the therapy cavity 403 by simultaneously applying negative pressure through the negative pressure lumen 530.

[0094] Referring back to Figures 10A and 10B, the component cavity 504 containing the electrical devices in some embodiments may be open to the ambient environment such that the electrical devices are exposed to the ambient environment. The component cavity 504 of the tissue interface 500 unlike the tissue interface 400 is already closed by an upper portion of the housing body 570 and, as such, may not require a cover such as, for example, the cap 411 to protect the electrical devices. In any event, the component cavity 504 may still be vented to the ambient environment to provide cooling to the electrical devices and a source of ambient pressure for the pressure sensor 516 disposed in the therapy cavity 503 as described above. The second dressing may further comprise a drape ring 513 covering the circumference of the flange 509 and the adjacent portion of the drape 406 to seal the therapy cavity 503 of the housing 501 over the manifold 408 and the tissue site 410.

[0095] In some embodiments, the pressure sensor 516, the temperature and humidity sensor 518, and the pH sensor 520 may be disposed in the housing 501 with each one having a sensing portion extending into the therapy cavity 503 of the housing 501 and associated electronics or outputs within the component cavity 504. In some example embodiments, the sensors may be coupled to or mounted on the wall 502 and electrically coupled to electrical components and circuits such as, for example, a microprocessor disposed within the

component cavity 504 by electrical conductors extending through the wall 502. In some preferred embodiments, the electrical conductors extend through pathways in the wall 502 while keeping the therapy cavity 503 electrically and pneumatically isolated from the component cavity 504. In this example embodiment, the wall 502 the circuit board 532 may be the wall 502 that covers an opening between the therapy cavity 503 and the component cavity 504.

[0096] In some embodiments, the electrical circuits and/or components associated with the sensors that are mounted on the circuit board 532 within the component cavity 504 may be electrically coupled to the controller 110 to interface with the rest of the therapy system 100 as described above. In some embodiments, the communications module 522 may be disposed in the component cavity 504 of the housing 501 and mounted on the circuit board 532 within the component cavity 504. For example, the electrical circuits and/or components associated with the sensors along with the terminal portion of the sensors may be electrically coupled to the controller 110 by wireless means such as an integrated device implementing Bluetooth[®] Low Energy wireless technology.

[0097] In some embodiments, the power source 524 may be disposed within the component cavity 504 of the housing 501, mounted on the circuit board 532, and secured in place to the circuit board 532 by a bracket 526. The power source 524 may be, for example, a battery that provides a 3-volt source for the communications module 522 and the other electronic components within the component cavity 504 associated with the sensors. In some example embodiments, the sensors, the electrical circuits and/or components associated with the sensors, the wall 502 and/or the circuit board 532, the communications module 522, and the power source 524 may be integrated as components of the sensor assembly 525. In some preferred embodiments, the wall 502 of the sensor assembly 525 may be the circuit board 532 as described above that provides a seal between tissue site 410 and the atmosphere when positioned over the opening between the therapy cavity 503 and the component cavity 504 of the housing 501.

[0098] Each of the sensors may comprise a sensing portion extending into the therapy cavity 503 of the housing 501 and a terminal portion electrically coupled to the electrical circuits and/or components within the component cavity 504. The pressure sensor 516 may be disposed on the circuit board 532 within the therapy cavity 503 of the sensor assembly 525 that provides a seal between tissue site 410 and the atmosphere as described above. In some embodiments, the pressure sensor 516 may be a differential gauge comprising a sensing

portion 542 and a terminal portion or vent 543. The vent 543 of the pressure sensor 516 may be fluidly coupled through the circuit board 532 to the component cavity 504 and the atmosphere by a vent hole 544 extending through the circuit board 532. The sensing portion 542 of the pressure sensor 516 may be positioned in close proximity to the manifold 408 to optimize fluid coupling and accurately measure the wound pressure (WP) at the tissue site 410.

[0099] In some embodiments, the pressure sensor 516 also may comprise a temperature sensor for measuring the temperature at the tissue site 410. In other embodiments, the humidity sensor 518 may comprise a temperature sensor for measuring the temperature at the tissue site 410. The sensor 518 may also be supported on the circuit board 532 of the sensor assembly 525. In some embodiments, the humidity sensor 518 may comprise a sensing portion that is electrically coupled through the circuit board 532 to a microprocessor mounted on the other side of the circuit board 532 within the component cavity 504. The sensing portion of the humidity sensor 518 may be fluidly coupled to the space within the therapy cavity 503 that includes a fluid pathway 545 extending from the port 577 to the port 576 represented by a series of dashed arrows and further represented by the arrow 534 and the arrow 531, respectively, to sense both the humidity and the temperature. The sensing portion of the humidity sensor 518 may be positioned within the fluid pathway 545 to limit direct contact with bodily fluids being drawn into the negative pressure lumen 530 from the tissue site 410 and to enhance exposure to the cleansing fluids from the instillation lumen 533.

[00100] The pH sensor 520 also may comprise a sensing portion disposed within the therapy cavity 503 that is electrically coupled through the circuit board 532 to an analog front-end device mounted on the other side of the circuit board 532 within the component cavity 504. The analog front-end device measures minute voltage potential changes provided by the sensing portion. The sensing portion of the pH sensor 520 may be fluidly coupled to the space within the therapy cavity 503 by being positioned in the fluid pathway 545 that extends into the negative pressure lumen 530 as described above. The sensing portion of the pH sensor 520 may be formed and positioned within the fluid pathway 545 so that the sensing portion directly contacts the wound fluid without contacting the wound itself so that the sensing portion of the pH sensor 520 does not interfere with the wound healing process. In some embodiments, the pH sensor 520 may be, for example, the pH sensor 450 shown in Figure 9A that comprises a pair of printed medical electrodes including a working electrode

451 and a reference electrode 452 as more fully described above. In some other embodiments, the pH sensor 520 may include a third electrode such as, for example, the pH sensor 460 shown in Figure 9B that comprises a third electrode or a counter electrode 462 in addition to the working electrode 451 and the reference electrode 452 of the pH sensor 450 as more fully described above. The sensing portion of the pH sensor 520 also may be positioned within the fluid pathway 545 to enhance exposure to the fluids from the instillation lumen 533 for the necessary cleansing and hydration. In the embodiments described above, the sensing portion of the pH sensors 420 and 520 when used with the combination of negative pressure and instillation, relies on using the vacuum induced flow created in the therapeutic cavities 403 and 503 to expose the sensing portion to wound fluids for measurement when wound fluids are being removed from the cavity and then using the instillation of cleansing fluids to clean and hydrate the sensing portion in order to recalibrate the pH sensors during routine instillation therapy procedures. The pH sensors may also be used along with other sensors to determine the type of fluid being instilled into the therapy cavity to prevent incorrect fluids from being delivered to, or left within, the therapy cavity, and then transmit a signal to the controller 110 that shuts down or overrides the delivery system upon detection. For example, the pH sensor may detect fluids that do not correspond to the correct pH value and upon detection overrides the delivery system.

[00101] In operation, the tissue interface 108 may be placed within, over, on, or otherwise proximate a tissue site, such as tissue site 150 as shown in Figure 4. The cover 106 may be placed over the tissue interface 108 and sealed to an attachment surface near the tissue site 150. For example, the cover 106 may be sealed to undamaged epidermis peripheral to a tissue site. Thus, the dressing 102 can provide a sealed therapeutic environment proximate to a tissue site, substantially isolated from the external environment, and the negative-pressure source 104 can reduce the pressure in the sealed therapeutic environment.

[00102] Some embodiments of therapy systems including, for example, the therapy system 100 including the dressing interface 400 and the dressing interface 500, are illustrative of a method for providing reduced-pressure to a tissue interface and sensing properties of fluids extracted from a tissue site for treating the tissue. In one example embodiment, the method may comprise positioning a housing of a dressing interface having an aperture in fluid communication with the tissue interface disposed adjacent the tissue site. The dressing interface may comprise a wall disposed within the housing to form a therapy cavity within

the housing and a component cavity fluidly sealed from the therapy cavity, wherein the therapy cavity opens to the aperture. Such dressing interface may further comprise a reduced-pressure port fluidly coupled to the therapy cavity and adapted to be fluidly coupled to a reduced-pressure source, and a control device disposed in the component cavity. The dressing interface may further comprise a pH sensor, a temperature sensor, a humidity sensor, and a pressure sensor, each having a sensing portion disposed within the therapy cavity and each electrically coupled to the control device through the wall. The method may further comprise applying reduced pressure to the therapy cavity to draw fluids from the tissue interface into the therapy cavity and out of the reduced-pressure port. The method may further comprise sensing the pH, temperature, humidity, and pressure properties of the fluids flowing through therapy cavity utilizing the sensing portion of the sensors and outputting signals from the sensors to the control device. The method may further comprise providing fluid data from the control device indicative of such properties and inputting the fluid data from the control device to the therapy system for processing the fluid data and treating the tissue site in response to the fluid data.

[00103] The systems, apparatuses, and methods described herein may provide other significant advantages over dressing interfaces currently available. For example, a patient may require two dressing interfaces for two tissue sites, but wish to use only a single therapy device to provide negative pressure to and collect fluids from the multiple dressing interfaces to minimize the cost of therapy. In some therapy systems currently available, the two dressing interfaces would be fluidly coupled to the single therapy device by a Y-connector. The problem with this arrangement is that the Y-connector embodiment would not permit the pressure sensor in the therapy device to measure the wound pressure in both dressing interfaces independently from one another. A significant advantage of using a dressing interface including *in situ* sensors, e.g., the dressing interface 400 including the sensor assembly 425 and the pressure sensor 416, is that multiple dressings may be fluidly coupled to the therapy unit of a therapy system and independently provide pressure data to the therapy unit regarding the associated dressing interface. Each dressing interface 400 that is fluidly coupled to the therapy unit for providing negative pressure to the tissue interface 108 and collecting fluids from the tissue interface 108 has the additional advantage of being able to collect and monitor other information at the tissue site, as well as the humidity data, temperature data, and the pH data being provided by the *in situ* sensors the sensor assembly 425. For example, the sensor assembly 425 may include accelerometers to determine the

patient's compliance with specific therapy treatments including various exercise routines and/or various immobilization requirements.

[00104] Another advantage of using the dressing interface 400 that includes a pressure sensor *in situ* such as, for example, the pressure sensor 416, is that the pressure sensor 416 can more accurately monitor the wound pressure (WP) at the tissue site and identify blockages and fluid leaks that may occur within the therapeutic space as described in more detail above. Another advantage of using a dressing interface including *in situ* sensors, e.g., the dressing interface 400, is that the sensor assembly 425 provides additional data including pressure, temperature, humidity, and pH of the fluids being drawn from the tissue site that facilitates improved control algorithms and wound profiling to further assist the caregiver with additional information provided by the therapy unit of the therapy system to optimize the wound therapy being provided and the overall healing progression of the tissue site when combined with appropriate control logic.

[00105] The disposable elements can be combined with the mechanical elements in a variety of different ways to provide therapy. For example, in some embodiments, the disposable and mechanical systems can be combined inline, externally mounted, or internally mounted. In another example, the therapy interface 400 may be a disposable element that is fluidly coupled to a therapy unit of a therapy system as described in more detail above.

[00106] While shown in a few illustrative embodiments, a person having ordinary skill in the art will recognize that the systems, apparatuses, and methods described herein are susceptible to various changes and modifications. For example, certain features, elements, or aspects described in the context of one example embodiment may be omitted, substituted, or combined with features, elements, and aspects of other example embodiments. Moreover, descriptions of various alternatives using terms such as "or" do not require mutual exclusivity unless clearly required by the context, and the indefinite articles "a" or "an" do not limit the subject to a single instance unless clearly required by the context. Components may be also be combined or eliminated in various configurations for purposes of sale, manufacture, assembly, or use. For example, in some configurations the dressing 102, the container 112, or both may be eliminated or separated from other components for manufacture or sale. In other example configurations, the controller 110 may also be manufactured, configured, assembled, or sold independently of other components.

[00107] The appended claims set forth novel and inventive aspects of the subject matter described above, but the claims may also encompass additional subject matter not

specifically recited in detail. For example, certain features, elements, or aspects may be omitted from the claims if not necessary to distinguish the novel and inventive features from what is already known to a person having ordinary skill in the art. Features, elements, and aspects described herein may also be combined or replaced by alternative features serving the same, equivalent, or similar purpose without departing from the scope of the invention defined by the appended claims.

CLAIMS

What is claimed is:

1. A dressing interface for connecting a source of fluids to a tissue interface and sensing properties of fluids at a tissue site, the dressing interface comprising:
 - a housing having a body including an outside surface and a therapy cavity therein, the therapy cavity having an opening configured to be in fluid communication with the tissue interface;
 - a reduced-pressure port fluidly coupled to the therapy cavity and adapted to fluidly couple a reduced-pressure source to the tissue interface;
 - an instillation port fluidly coupled to the therapy cavity and adapted to fluidly couple an instillation source to the tissue interface;
 - a control device having a microprocessor and a wireless transmitter disposed on the housing outside of the therapy cavity, wherein the wireless transmitter module is electrically coupled to the processor;
 - a pressure sensor having a sensing portion disposed within the therapy cavity and electrically coupled to the microprocessor through the body of the housing;
 - and
 - a pH sensor having a sensing portion disposed within the therapy cavity and electrically coupled to the microprocessor through the body of the housing.
2. The dressing interface of claim 1, further comprising a component cavity enclosing the control device and sealing the control device from the therapy cavity.
3. The dressing interface of claim 1, further comprising a vent port fluidly coupled to the therapy cavity and adapted to enable airflow into the therapy cavity.
4. The dressing interface of claim 1, further comprising a temperature sensor and a humidity sensor, each sensor having a sensing portion disposed within the therapy cavity and electrically coupled to the microprocessor through the body of the housing.
5. The dressing interface of claim 4, wherein the sensing portion of the humidity sensor and the temperature sensor are disposed proximate the instillation port.

6. The dressing interface of claim 1, wherein the sensing portion of the pressure sensor is disposed in the therapy cavity so that the sensing portion is proximate the tissue interface when positioned at the tissue site.
7. The dressing interface of claim 1, wherein the sensing portion of the pH sensor is disposed proximate the instillation port.
8. The dressing interface of claim 1, wherein the pH sensor comprises an electrode disposed within the therapy cavity and electrically coupled to an input of a front-end amplifier disposed on outside of the therapy cavity, the front-end amplifier having an output electrically coupled to the microprocessor.
9. The dressing interface of claim 8, wherein the electrode is disposed within the therapy cavity so that the electrode does not contact the tissue interface when positioned at the tissue site.
10. The dressing interface of claim 8, wherein the electrode comprises a printed medical electrode.
11. The dressing interface of claim 10, wherein the printed medical electrode comprises a working electrode and a reference electrode.
12. The dressing interface of claim 11, further comprising a counter electrode.
13. The dressing interface of claim 12, further comprising a vent port fluidly coupled to the therapy cavity to enable airflow into the therapy cavity, and a fluid conductor fluidly coupled to the reduced-pressure port and the vent port.
14. The dressing interface of claim 13, wherein the fluid conductor is a conduit having a primary lumen fluidly coupled to the reduced-pressure port and at least one auxiliary lumen fluidly coupled to the vent port.
15. The dressing interface of claim 14, wherein the fluid conductor comprises side-by-side lumens including a primary lumen fluidly coupled to the reduced-pressure port and at least one auxiliary lumen fluidly coupled to the vent port.

16. The dressing interface of claim 13, wherein the fluid conductor is a conduit having a primary lumen fluidly coupled to the reduced-pressure port and at least one auxiliary lumen fluidly coupled to the instillation port.
17. The dressing interface of claim 1, further comprising a baffle disposed proximate the reduced-pressure port and extending into the therapy cavity to direct the flow of negative pressure within the therapy cavity.
18. The dressing interface of claim 1, further comprising a baffle disposed proximate the installation port and extending into the therapy cavity to direct the flow of fluids within the therapy cavity.
19. The dressing interface of claim 1, further comprising a first baffle disposed proximate the reduced-pressure port and a second baffle disposed proximate the installation port, both extending into the therapy cavity to direct the flow of fluids within the therapy cavity.

20. A method of applying reduced-pressure to a tissue interface and sensing properties of fluids at a tissue site for treating the tissue site, the method comprising:
- positioning a dressing interface on the tissue site, the dressing interface having a housing including an outside surface and a therapy cavity having an opening configured to be in fluid communication with the tissue interface, and wherein the dressing interface further comprises:
 - a reduced-pressure port fluidly coupled to the therapy cavity and adapted to fluidly couple a reduced-pressure source to the therapy cavity,
 - an instillation port fluidly coupled to the therapy cavity and adapted to fluidly couple an instillation source to the therapy cavity, and
 - a pH sensor and a pressure sensor disposed within the therapy cavity and each electrically coupled to a control device; and
 - applying reduced pressure to the therapy cavity to draw fluids from the tissue interface and into the therapy cavity;
 - sensing pH and pressure properties of the fluids within the therapy cavity provided from the pressure sensor and the pH sensor; and
 - instilling fluids into the therapy cavity to cleanse the pressure sensor and the pH sensor.
21. The method of claim 20, further comprising providing fluid data indicative of the pH and pressure properties to the control device.
22. The method of claim 20, further comprising processing the fluid data for presenting information for treating the tissue site.
23. The method of claim 20, further comprising providing airflow into the therapy cavity through a vent port fluidly coupling a source of airflow to the therapy cavity.
24. The method of claim 23, further comprising controlling the airflow into the therapy cavity by a valve fluidly coupled to the vent port.
25. The method of claim 20, further comprising transmitting the fluid data using a wireless transmitter module electrically coupled to the control device.

26. The method of claim 20, further comprising sensing humidity and temperature of the fluids within the therapy cavity utilizing a humidity and temperature sensor disposed within the therapy cavity and electrically coupled to the control device.
27. The method of claim 26, wherein the port is further adapted to be fluidly coupled to the therapy cavity to a source of instillation fluids, the method further comprising providing instillation fluids to the therapy cavity; sensing the pH, pressure, humidity, and temperature properties of the fluids; and providing fluid data indicative of such properties to the control device.
28. The method of claim 27, wherein the pH, pressure, humidity, and temperature properties of the fluids are sensed prior to providing instillation fluids to the therapy cavity.
29. The method of claim 27, wherein the pH, pressure, humidity, and temperature properties of the fluids are sensed while providing instillation fluids to the therapy cavity.
30. The method of claim 27, wherein the pH, pressure, humidity, and temperature properties of the fluids are sensed after providing instillation fluids to the therapy cavity.
31. The method of claim 30, wherein the pH, pressure, humidity, and temperature properties of the fluids are sensed after providing instillation fluids to the therapy cavity and removing instillation fluids from the therapy cavity.

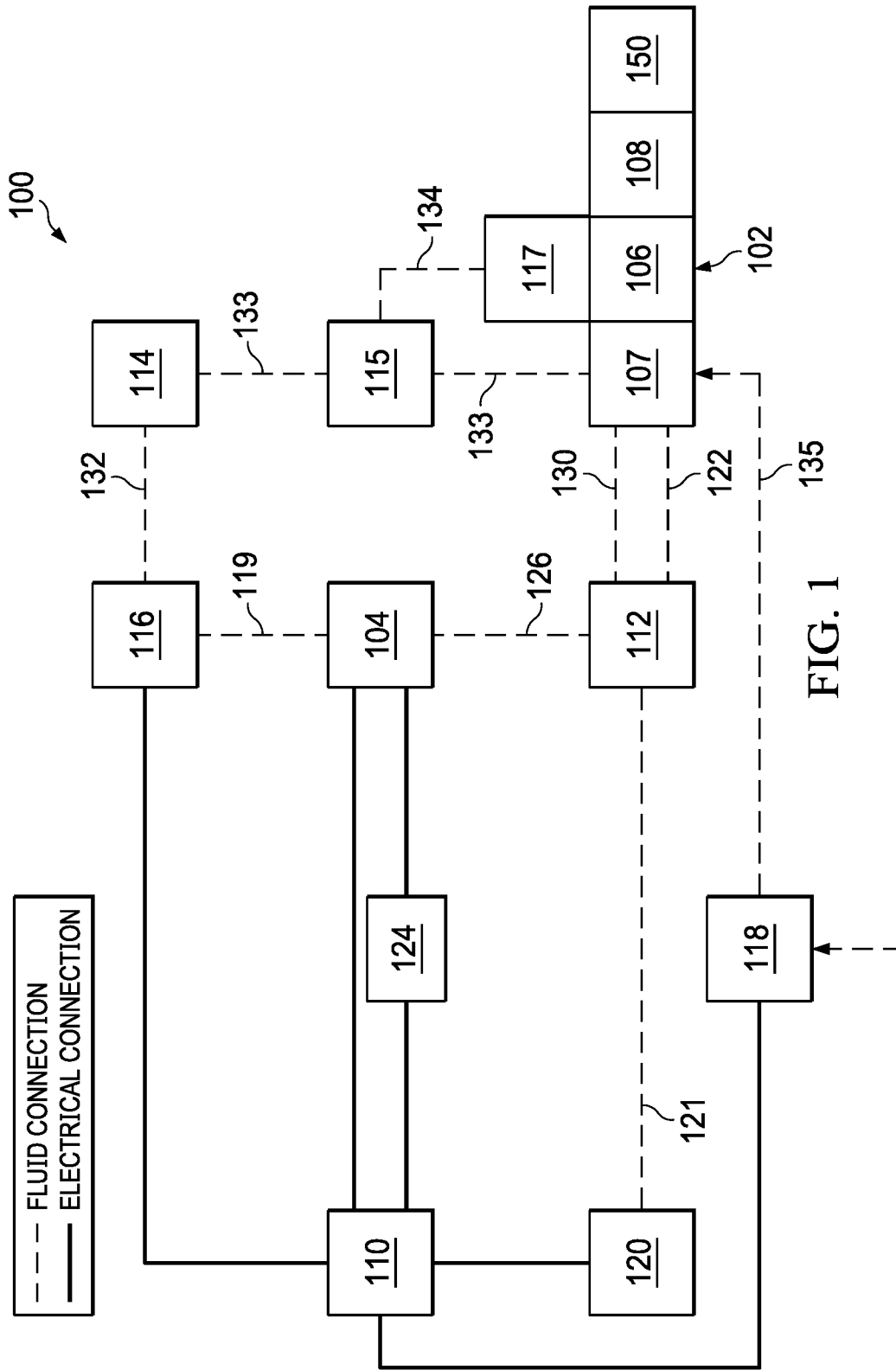

FIG. 1

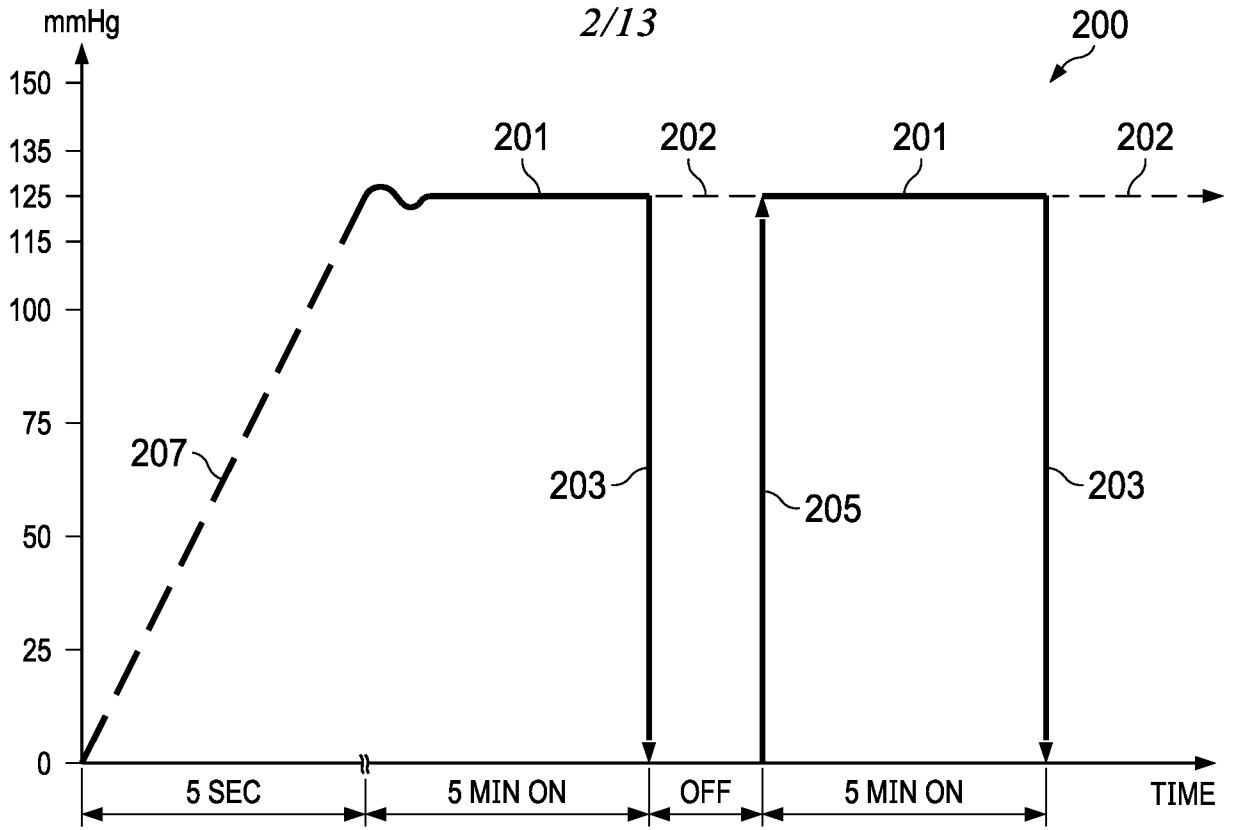

FIG. 2A

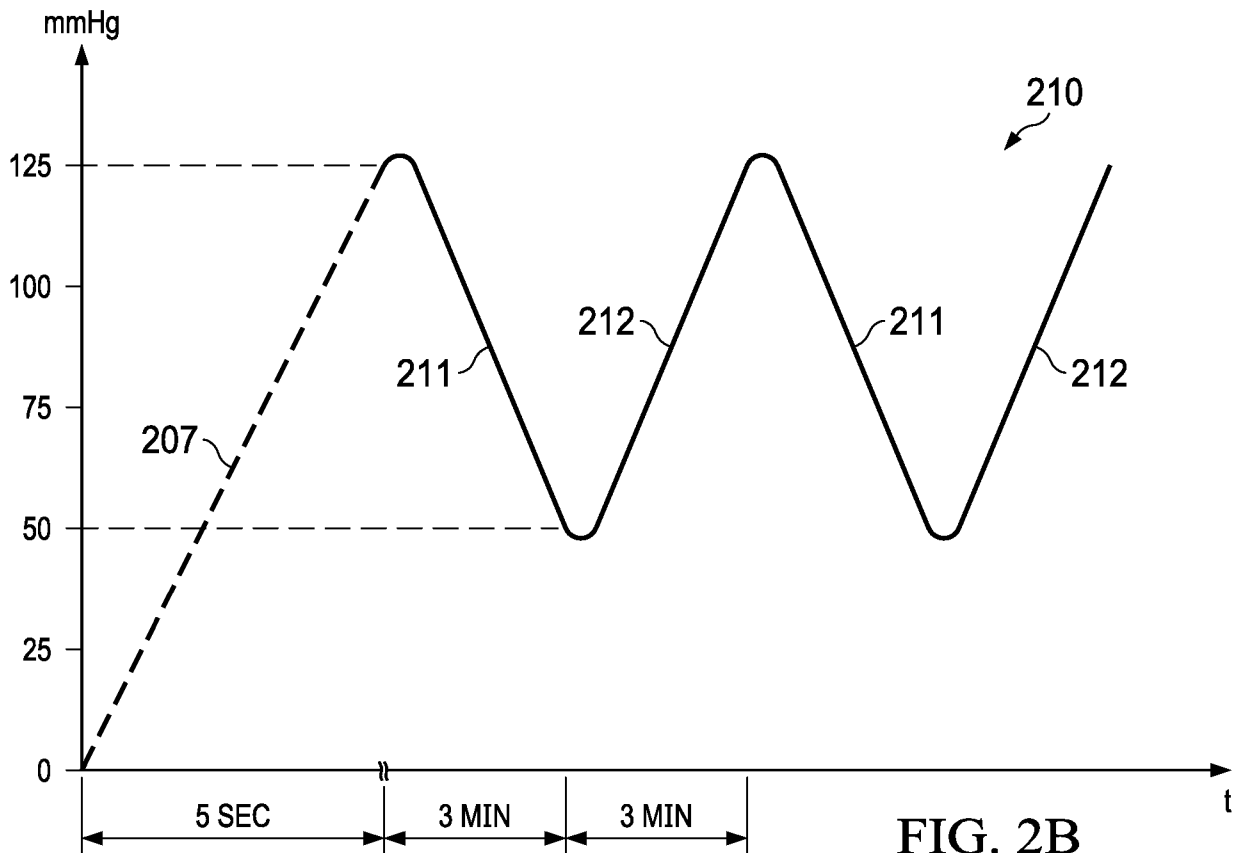

FIG. 2B

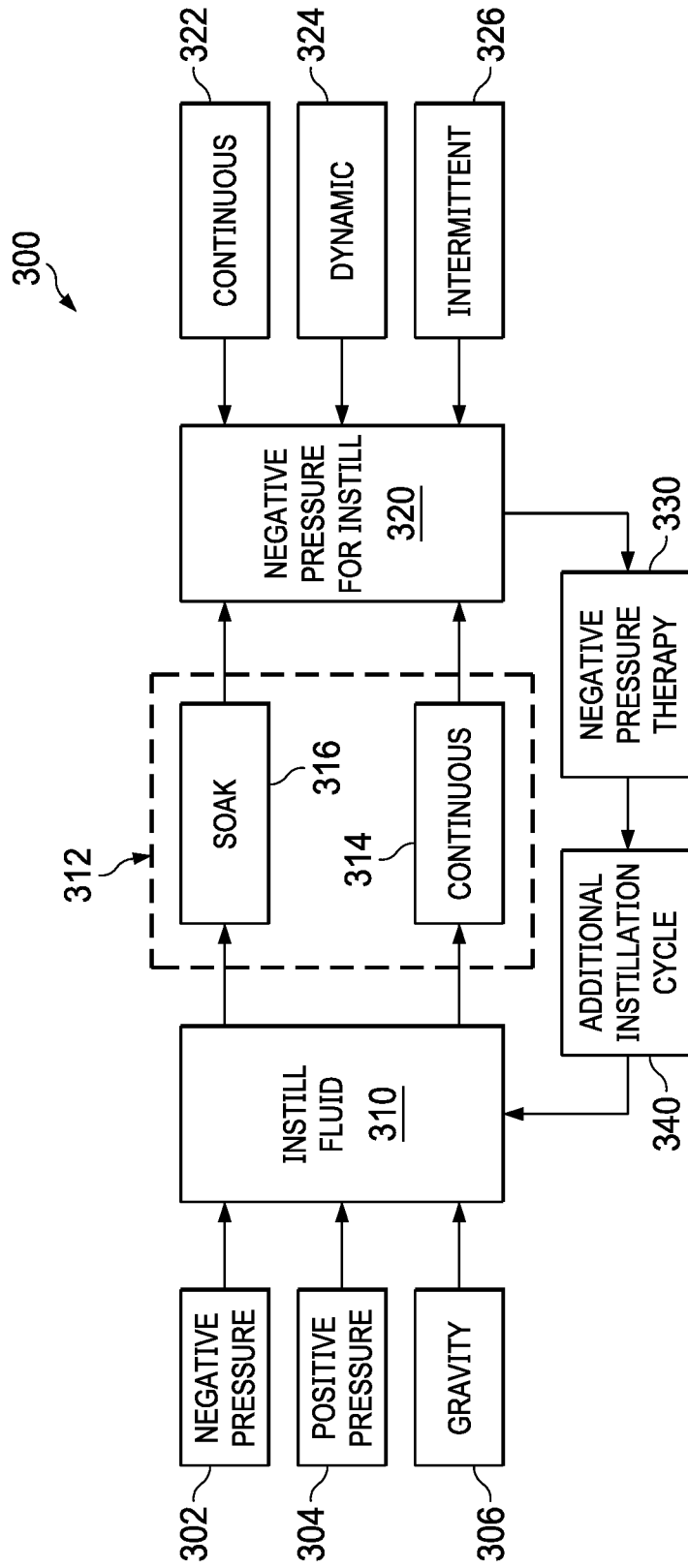

FIG. 3

4/13

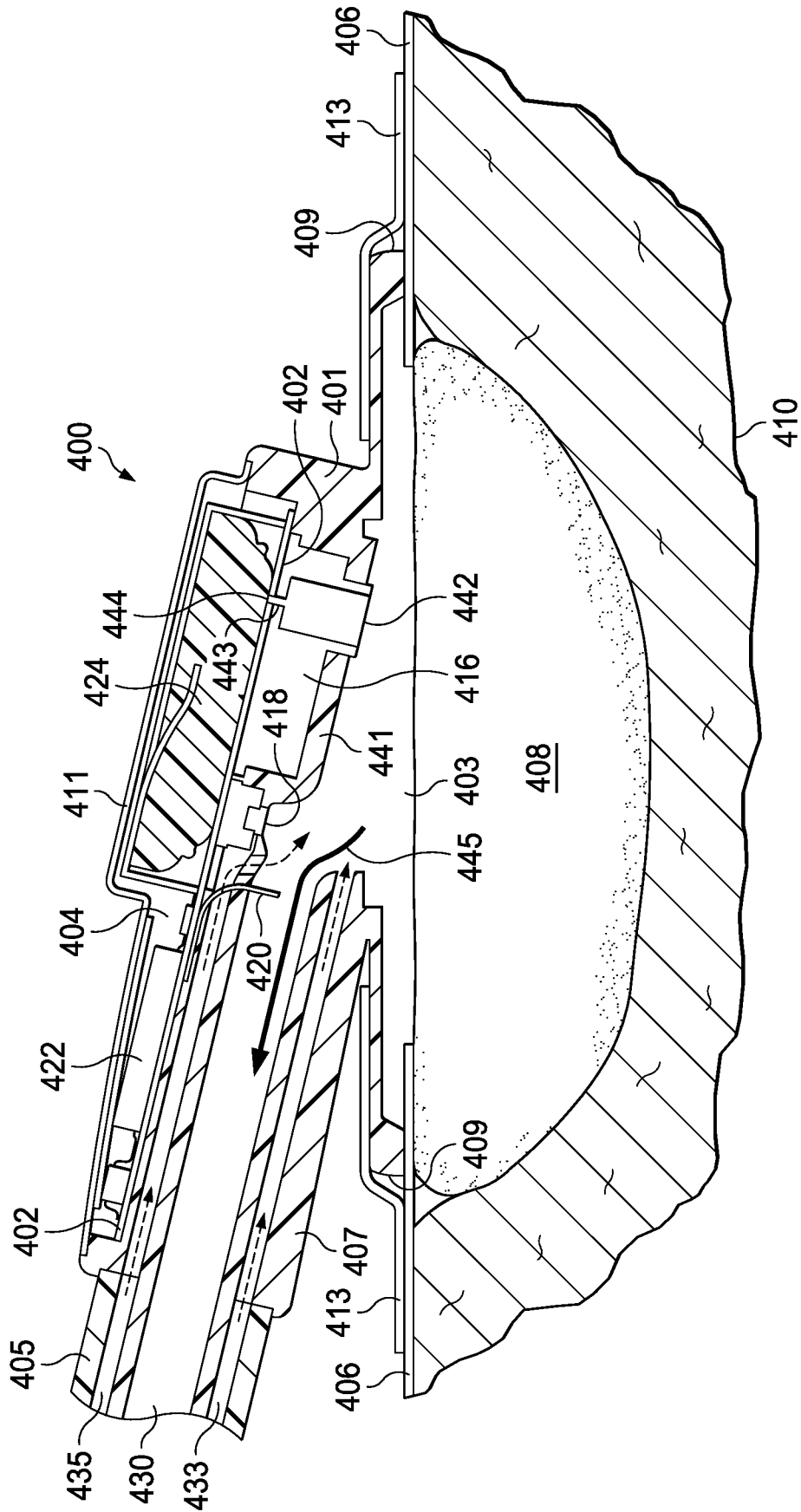

FIG. 4

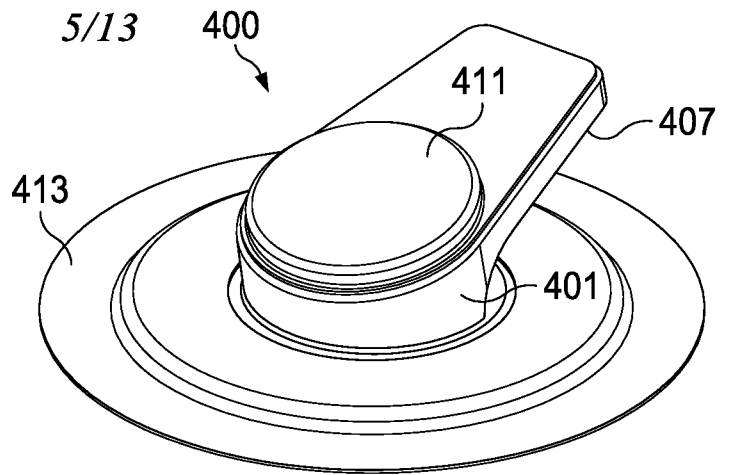

FIG. 5A

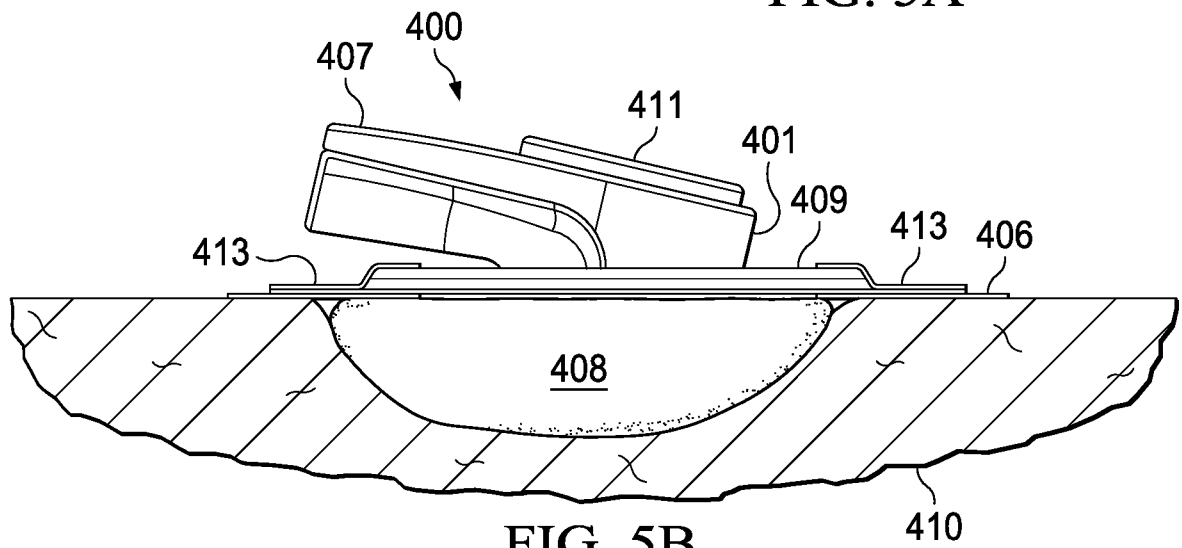

FIG. 5B

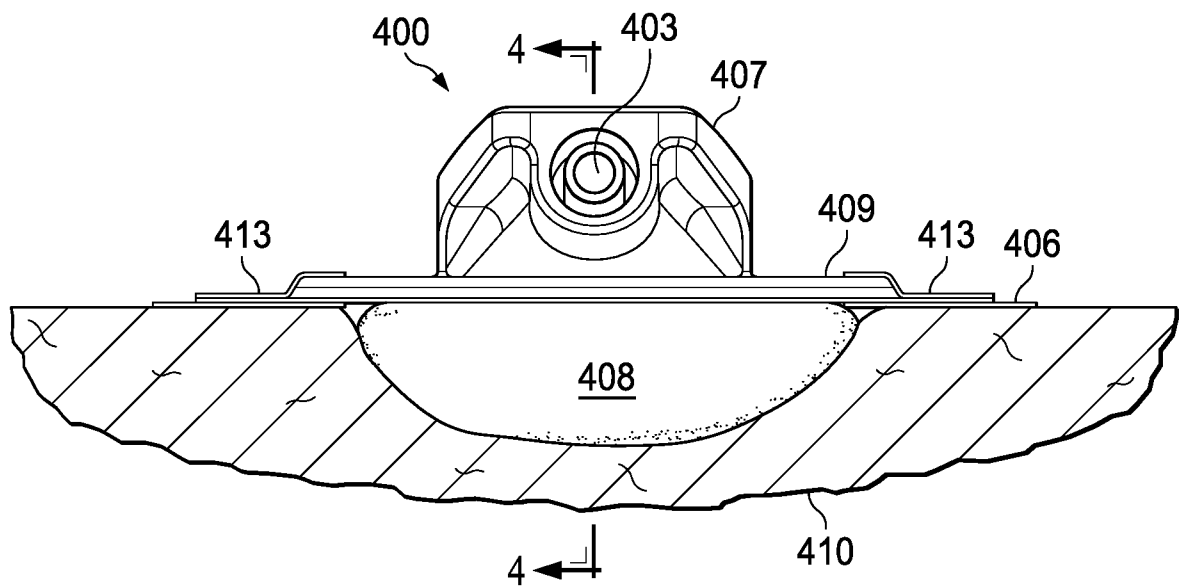

FIG. 5C

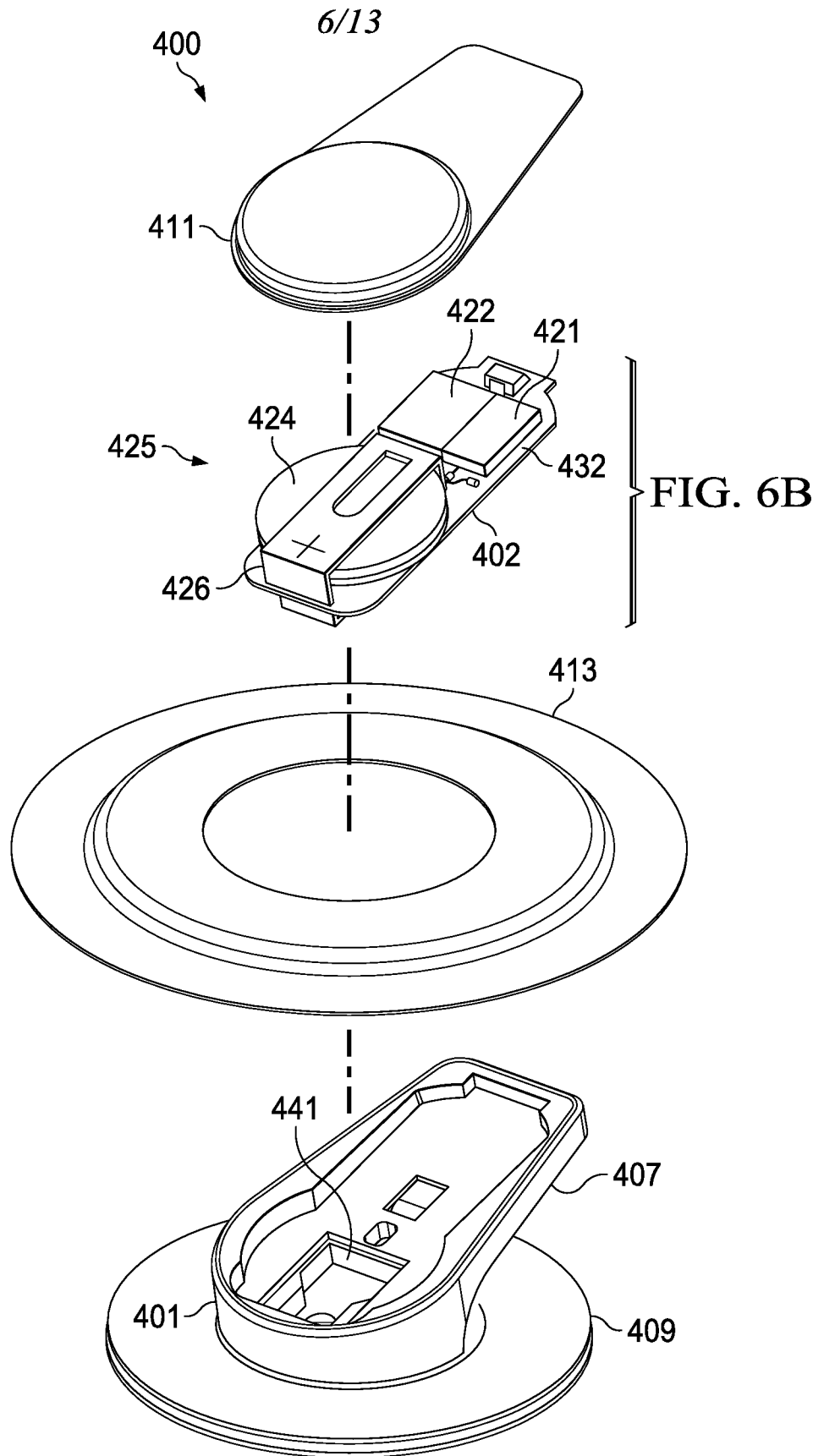

FIG. 6A

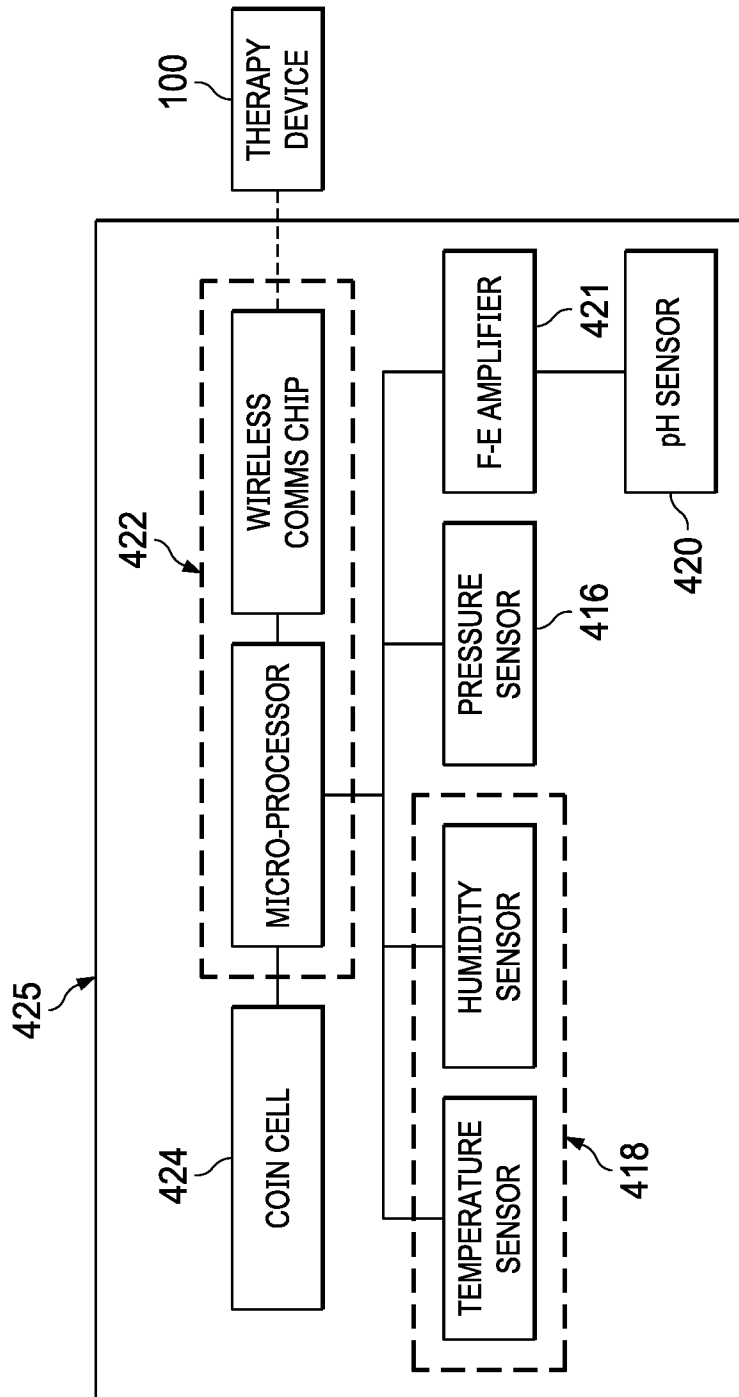

FIG. 6B

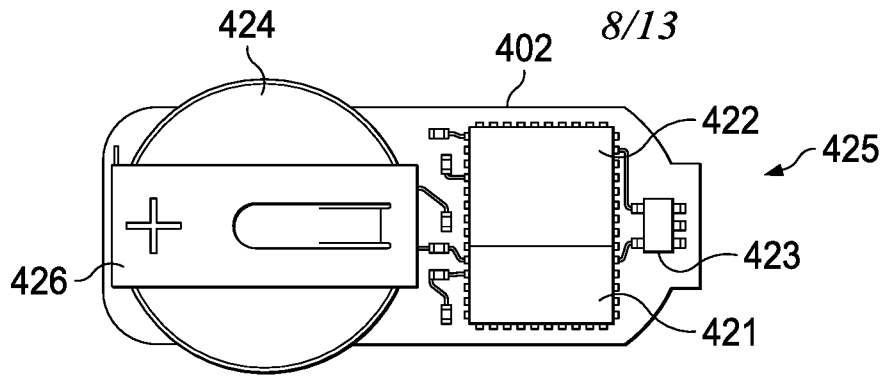

FIG. 7A

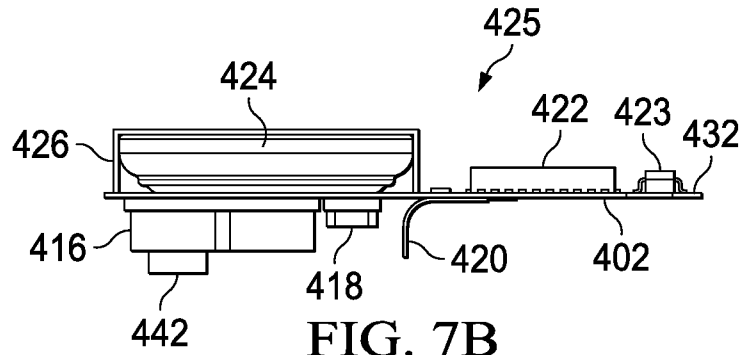

FIG. 7B

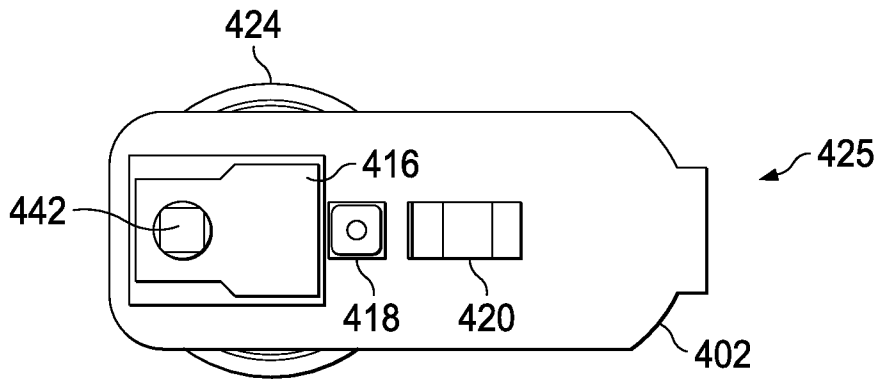

FIG. 7C

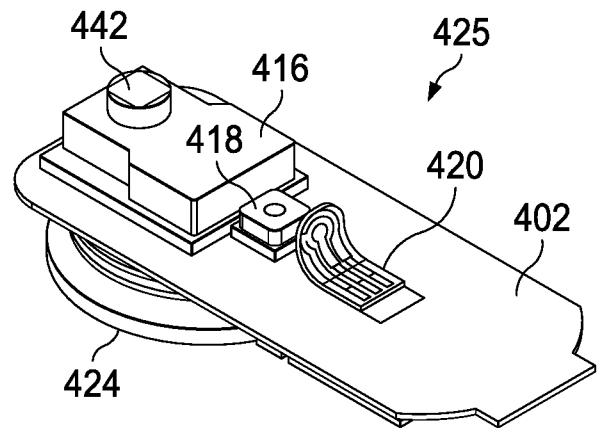
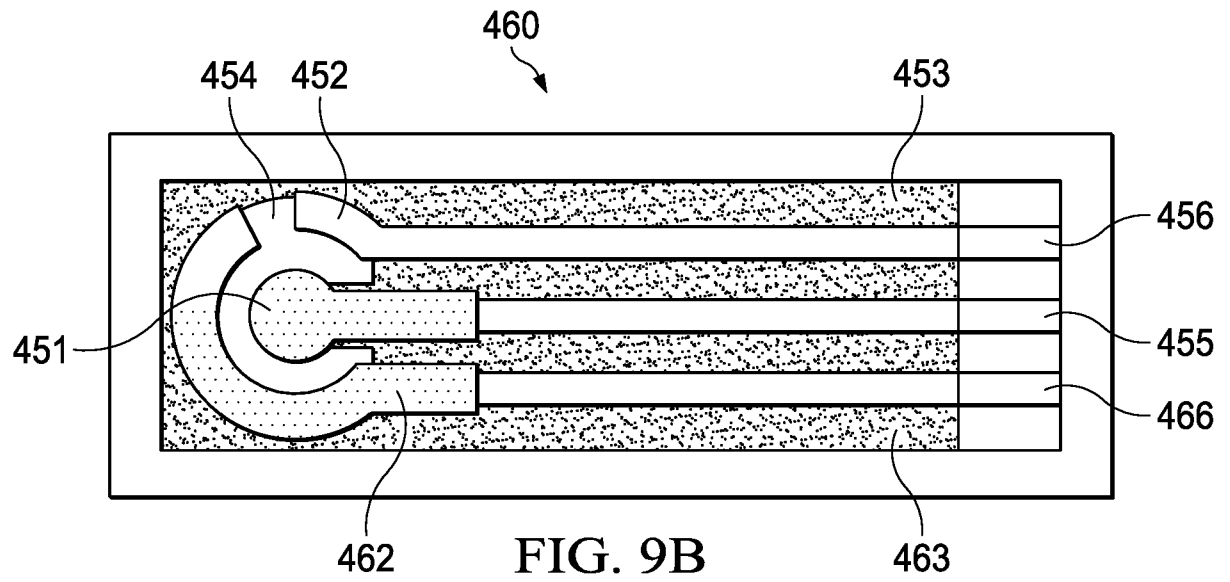
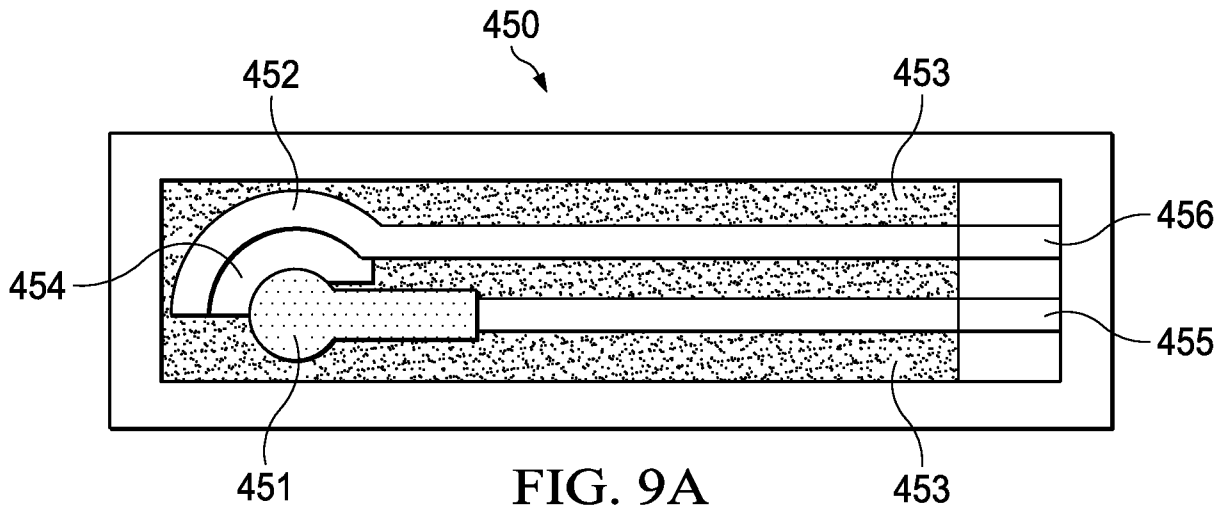
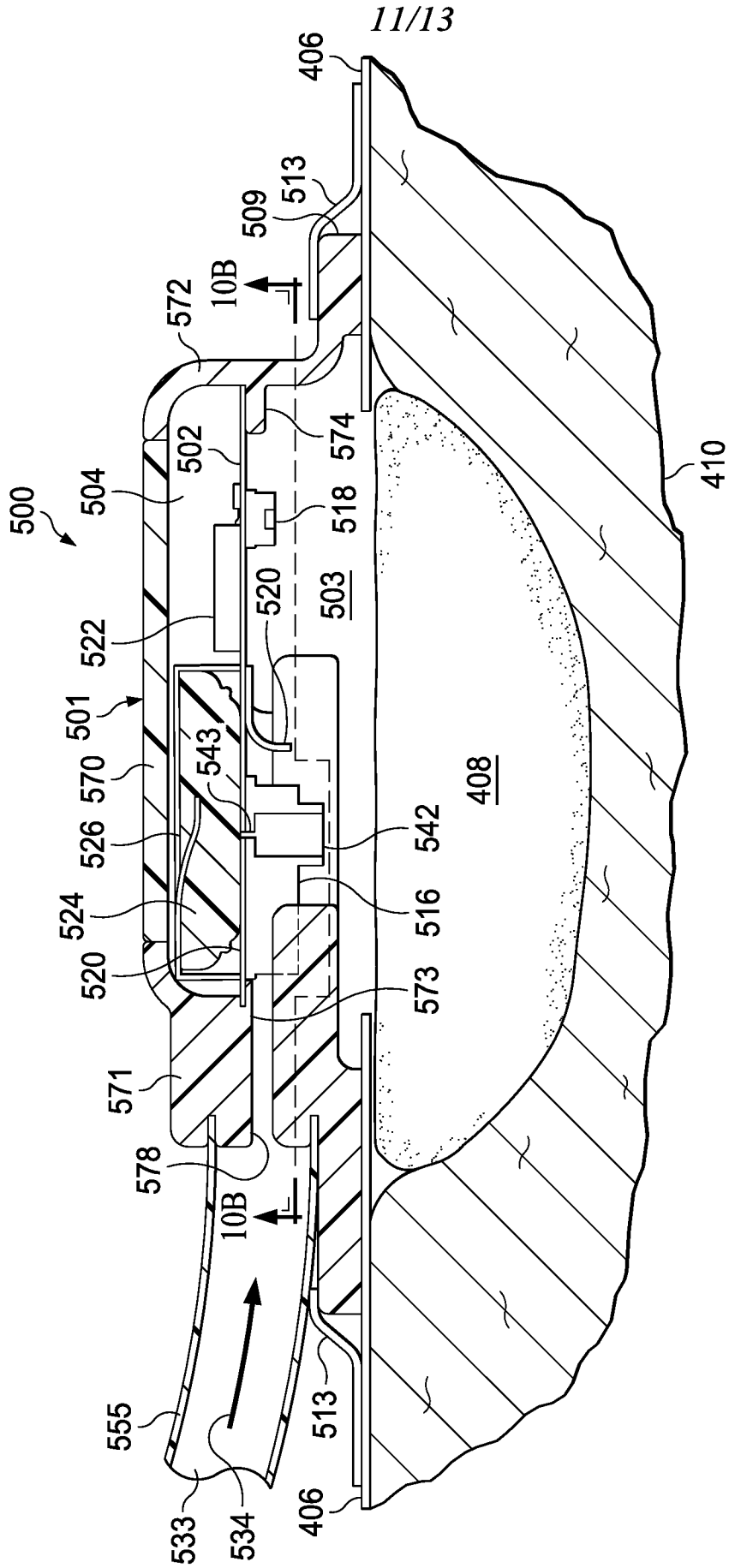

FIG. 7D





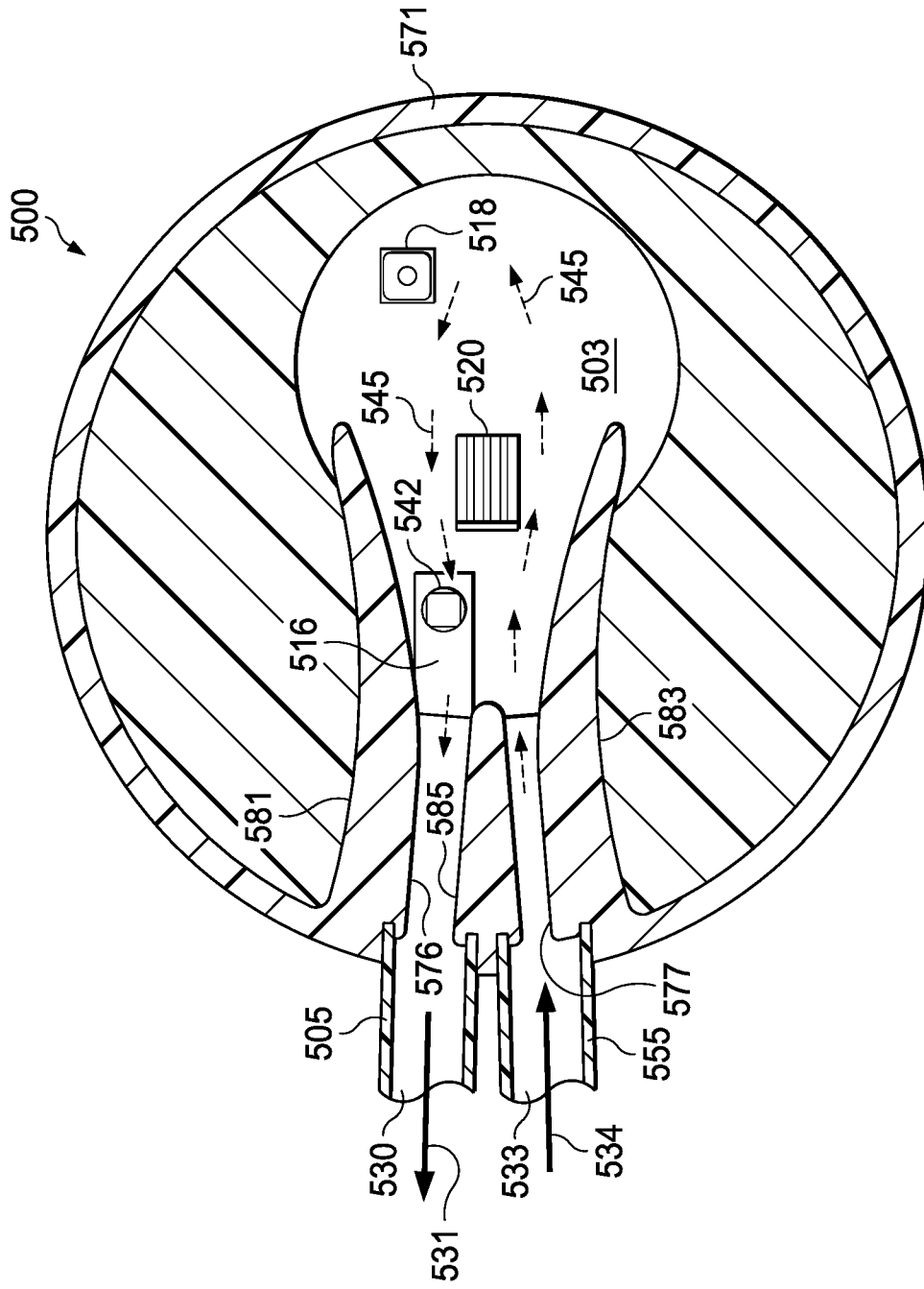

FIG. 10B

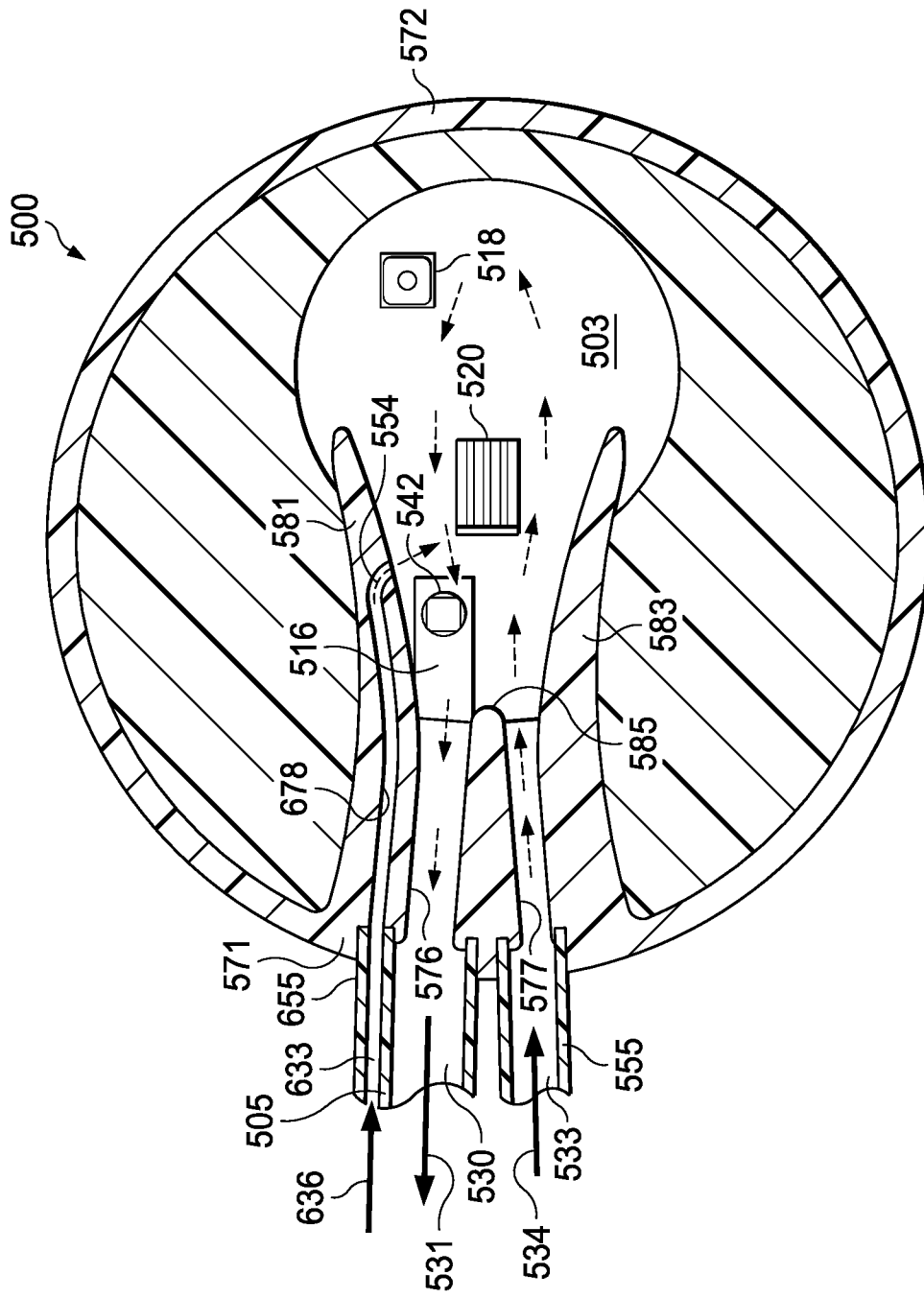

FIG. 11

INTERNATIONAL SEARCH REPORT

International application No
PCT/US2019/013675

A. CLASSIFICATION OF SUBJECT MATTER
INV. A61M1/00
ADD.

According to International Patent Classification (IPC) or to both national classification and IPC

B. FIELDS SEARCHED
Minimum documentation searched (classification system followed by classification symbols)
A61M

Documentation searched other than minimum documentation to the extent that such documents are included in the fields searched

Electronic data base consulted during the international search (name of data base and, where practicable, search terms used)
EPO-Internal, WPI Data

C. DOCUMENTS CONSIDERED TO BE RELEVANT

Category*	Citation of document, with indication, where appropriate, of the relevant passages	Relevant to claim No.
X	WO 2017/195038 A1 (SMITH & NEPHEW [GB]) 16 November 2017 (2017-11-16) paragraphs [0090] - [0091], [0096]; figures 1, 2B, 2C, 3A -----	1-19
X	EP 2 331 162 A1 (KCI LICENSING INC [US]) 15 June 2011 (2011-06-15) paragraphs [0039] - [0040] -----	1-19
X	WO 2015/073885 A1 (MIKUS PAUL [US]; RUBINSKY LIEL [US]; RUBINSKY BORIS [US]) 21 May 2015 (2015-05-21) paragraphs [0028] - [0031]; figure 1 -----	1-19
X	US 2013/165821 A1 (FREEDMAN BRETT [US] ET AL) 27 June 2013 (2013-06-27) paragraphs [0165], [0192]; figure 1A -----	1-19

Further documents are listed in the continuation of Box C.

See patent family annex.

* Special categories of cited documents :

- "A" document defining the general state of the art which is not considered to be of particular relevance
- "E" earlier application or patent but published on or after the international filing date
- "L" document which may throw doubts on priority claim(s) or which is cited to establish the publication date of another citation or other special reason (as specified)
- "O" document referring to an oral disclosure, use, exhibition or other means
- "P" document published prior to the international filing date but later than the priority date claimed

- "T" later document published after the international filing date or priority date and not in conflict with the application but cited to understand the principle or theory underlying the invention
- "X" document of particular relevance; the claimed invention cannot be considered novel or cannot be considered to involve an inventive step when the document is taken alone
- "Y" document of particular relevance; the claimed invention cannot be considered to involve an inventive step when the document is combined with one or more other such documents, such combination being obvious to a person skilled in the art
- "&" document member of the same patent family

Date of the actual completion of the international search

23 April 2019

Date of mailing of the international search report

08/05/2019

Name and mailing address of the ISA/
European Patent Office, P.B. 5818 Patentlaan 2
NL - 2280 HV Rijswijk
Tel. (+31-70) 340-2040,
Fax: (+31-70) 340-3016

Authorized officer

Westsson, David

INTERNATIONAL SEARCH REPORT

International application No.
PCT/US2019/013675

Box No. II Observations where certain claims were found unsearchable (Continuation of item 2 of first sheet)

This international search report has not been established in respect of certain claims under Article 17(2)(a) for the following reasons:

1. Claims Nos.: 20-31
because they relate to subject matter not required to be searched by this Authority, namely:
Claims 20-31 refer to a method for treatment of the human or animal body by therapy, which is against Rule 39.1(iv) PCT and Rule 67.1(iv). The reason is that they include the step of treating a tissue site by applying a dressing to a tissue site and by applying a negative pressure and a fluid to the dressing.
2. Claims Nos.:
because they relate to parts of the international application that do not comply with the prescribed requirements to such an extent that no meaningful international search can be carried out, specifically:
3. Claims Nos.:
because they are dependent claims and are not drafted in accordance with the second and third sentences of Rule 6.4(a).

Box No. III Observations where unity of invention is lacking (Continuation of item 3 of first sheet)

This International Searching Authority found multiple inventions in this international application, as follows:

1. As all required additional search fees were timely paid by the applicant, this international search report covers all searchable claims.
2. As all searchable claims could be searched without effort justifying an additional fees, this Authority did not invite payment of additional fees.
3. As only some of the required additional search fees were timely paid by the applicant, this international search report covers only those claims for which fees were paid, specifically claims Nos.:
4. No required additional search fees were timely paid by the applicant. Consequently, this international search report is restricted to the invention first mentioned in the claims; it is covered by claims Nos.:

Remark on Protest

- The additional search fees were accompanied by the applicant's protest and, where applicable, the payment of a protest fee.
- The additional search fees were accompanied by the applicant's protest but the applicable protest fee was not paid within the time limit specified in the invitation.
- No protest accompanied the payment of additional search fees.

INTERNATIONAL SEARCH REPORT

Information on patent family members

International application No PCT/US2019/013675

Patent document cited in search report	Publication date	Patent family member(s)	Publication date
WO 2017195038 A1	16-11-2017	AU 2017264907 A1	20-12-2018
		CA 3023772 A1	16-11-2017
		CN 109069712 A	21-12-2018
		EP 3454918 A1	20-03-2019
		SG 11201809829U A	28-12-2018
		WO 2017195038 A1	16-11-2017

EP 2331162 A1	15-06-2011	AU 2009298912 A1	08-04-2010
		CA 2735898 A1	08-04-2010
		CN 102137687 A	27-07-2011
		EP 2331162 A1	15-06-2011
		JP 5599803 B2	01-10-2014
		JP 2012504460 A	23-02-2012
		KR 20110087277 A	02-08-2011
		RU 2011107114 A	10-11-2012
		US 2010087791 A1	08-04-2010
WO 2010039481 A1	08-04-2010		

WO 2015073885 A1	21-05-2015	EP 3068327 A1	21-09-2016
		EP 3068925 A1	21-09-2016
		US 2016287867 A1	06-10-2016
		US 2016296269 A1	13-10-2016
		WO 2015073877 A1	21-05-2015
		WO 2015073885 A1	21-05-2015

US 2013165821 A1	27-06-2013	AU 2012332941 A1	03-04-2014
		CA 2853106 A1	10-05-2013
		EP 2773393 A2	10-09-2014
		US 2013165821 A1	27-06-2013
		US 2014066868 A1	06-03-2014
		US 2017007752 A1	12-01-2017
		WO 2013066694 A2	10-05-2013
