

(19)



Europäisches Patentamt

European Patent Office

Office européen des brevets



(11)

EP 0 631 932 B1

(12)

EUROPEAN PATENT SPECIFICATION

(45) Date of publication and mention
of the grant of the patent:
08.01.1997 Bulletin 1997/02

(51) Int. Cl.⁶: **B65B 7/28, A61J 3/07**

(21) Application number: **94109003.7**

(22) Date of filing: **13.06.1994**

(54) Method and apparatus for the automatic assembly of cup-like bodies

Verfahren und Vorrichtung für das automatische Zusammensetzen von becherförmigen Körpern

Procédé et dispositif pour l'assemblage automatique de corps en forme de coques

(84) Designated Contracting States:
**AT BE CH DK ES FR GB GR IE IT LI LU MC NL PT
SE**

(30) Priority: **29.06.1993 IT TO930469**

(43) Date of publication of application:
04.01.1995 Bulletin 1995/01

(73) Proprietor: **Ferrero S.p.A.
I-12051 Alba (Cuneo) (IT)**

(72) Inventor: **Cognigni, Silvano
I-62018 Potenza Picena (Macerata) (IT)**

(74) Representative: **Bosotti, Luciano et al
c/o JACOBACCI & PERANI S.p.A.
Corso Regio Parco, 27
10152 Torino (IT)**

(56) References cited:
**DE-A- 2 708 147 FR-A- 2 023 426
GB-A- 883 467 US-A- 3 527 015
US-A- 3 707 825 US-A- 4 168 599**

EP 0 631 932 B1

Note: Within nine months from the publication of the mention of the grant of the European patent, any person may give notice to the European Patent Office of opposition to the European patent granted. Notice of opposition shall be filed in a written reasoned statement. It shall not be deemed to have been filed until the opposition fee has been paid. (Art. 99(1) European Patent Convention).

Description

The present invention relates to apparatus for the assembly of containers and was developed with particular attention to its possible use, for example, in the automatic assembly of containers for small toys, trinkets and the like intended to be inserted as "surprises" in food products or the like.

In this field of application, an arrangement has been known for many years whereby a surprise is put inside a container (commonly known as a "little barrel") made up of two cup-like bodies which can be fitted together by end-to-end engagement of their open ends.

Very often, the surprise is of a type requiring assembly and a sheet of assembly instructions and/or a sheet of transfers to be applied to the surprise must be put into the container as well as the component parts: usually, this sheet or sheets are rolled into a tube for insertion in one of the two cup-like bodies, in contact with its inner surface.

In view of the high production rate of the products in which the container must be inserted (especially in the case of confectionery manufactured on an industrial scale) and considering the need to keep the cost of the surprise as low as possible, it is definitely desirable to be able to fill and assemble the container automatically, especially as far as the following operations are concerned:

- picking up the component parts of the surprise in order to put them into the container,
- inserting the parts into the container (usually into one of its cup-like constituents), together with the sheet or sheets carrying the assembly instructions and/or decorative transfers, and
- assembling the container by coupling its two constituent cup-like bodies.

Until now, it has been practically impossible to carry out the operations described above entirely automatically. In order to ensure that the finished product was reliable (especially to ensure that the container contains all parts of the surprise, that the sheet or sheets are inserted and that the container is securely closed), manufacturers were therefore obliged to resort to manual packaging which involved considerable problems of organization, cost and, above all, hygiene of the finished product.

The object of the present invention is to provide a solution to the last of the problems described above (that is the automatic assembly of the container), the other problems being solved by arrangements which are the subject of other European patent applications, filed on the same date by the same applicant.

According to the present invention, this object is achieved thanks to an apparatus having the characteristics specified in the Claims which follow. The invention also concerns the related method.

Reference is made to US-A-3 527 015 and FR-A-2

023 426.

The invention will now be described, purely by way of non-limitative example, with reference to the appended drawings, in which:

5

Figure 1 schematically illustrates the structure of a container which can be assembled automatically using the apparatus of the invention,

10

Figure 2 is an overall side elevation of an apparatus according to the invention,

15

Figure 3 is a section taken on the line III-III of Figure 2, and

20

Figures 4 to 6 correspond substantially to the section of Figure 3 and illustrate the operating sequence of the apparatus of the invention.

25

In Figure 1, a container (little barrel), generally indicated 1, is of the type commonly used to hold small toys, trinkets or the like ("surprises"), usually of a type requiring assembly, inside hollow products, for example hollow food products such as confectionery (chocolate eggs and the like). It should be noted however that this use, which will be constantly referred to in the following description, is described purely by way of example as the scope of the invention extends in general to the assembly of containers intended for any purpose or use.

30

The container 1 is usually constituted by two cup-like bodies 2, 3, of flexible plastics material, intended for engagement by their open ends in a general male-female arrangement.

35

To this end, one of the two bodies (for example the body 3 in the embodiment illustrated) has at its open end a cylindrical neck portion 4 intended to penetrate the open end of the other body 2. This is in order to ensure secure end-to-end engagement, which is usually further strengthened by the presence of ribs 4a on the outer surface of the neck portion 4 for engagement in cooperating grooves (not shown in the drawings) in the inner surface of the open end of the body 2.

40

The surprise, generally indicated S, is fitted into the body 3 (following various criteria, for example by adopting the solutions described in other patent applications for industrial invention filed on the same date by the same applicant) which is held with its open end upwards. Usually, at least some of the component parts (elements) of the surprise S (put into the container loose 1) project from the neck portion 4 of the body 3. This is true also of the sheet or sheets F rolled into a tube and fitted against the inner peripheral wall of the body 3. The sheets F normally carry the instructions for assembling the surprise and/or transfers for applying to the surprise itself.

45

Figure 2 shows an apparatus (collector), generally indicated 10, for use according to the invention in the automatic assembly of containers such as the container 1 of Figure 1.

50

55

In the embodiment which is currently preferred (that illustrated in Figure 2), the apparatus of the invention is able to close a plurality of containers 1, for example four,

simultaneously.

In order to do this, the apparatus 10 has a plurality of cavities 11 which define respective vertical-axis tubular ducts arranged in a gantry over a conveyor 12 (for example a motor-driven conveyor belt) on which the lower bodies 3 of the containers 1 advance horizontally in trays or pallets 13, the containers having been filled in advance (by means which are assumed to be known) with the surprises S and the sheets F.

Usually, the trays 13 are constituted by matrix-type holding structures with several rows of vertical-axis apertures 14 for holding the bodies 3. In the embodiment illustrated, each row has four apertures 14 on which the apparatus 10 acts simultaneously.

In practice, this result may be achieved by ensuring that the conveyor 12 transports the trays 13 in a direction perpendicular to the longer axis of the apparatus 10 and that the conveyor 12 is advanced (according to well known criteria which do not need to be described here) in such a way that, at each step, a corresponding row of apertures 14 (containing a corresponding row of bodies 3) is brought into alignment with the four vertical-axis cavities 11 in the apparatus 10.

Above and below the apparatus 10, in exact vertical alignment with the cavities 11, are pusher members, lower 15 and upper 16 respectively, constituted by pistons which are driven either pneumatically or electrically (for example electromagnetically).

In particular, the lower pushers 15 pass through corresponding apertures (typically in a plate 12a - Figures 3 to 6) in the conveyor plane in which the conveyor 12 operates. The apertured plate 12a interrupts the active conveyor surface of the conveyor 12 itself: it is usually preferred for the conveyor 12, if it is constituted by a belt, to have a continuous surface which is thus free of openings through which the pusher members 15 could pass.

The function of the pushers 15 is to lift the bodies 3 from the apertures 14 in the trays 13 and to push them up into the chambers 11 in the apparatus 10. The purpose of this is to couple them, inside these chambers, with the cooperating upper bodies 2, each of which is carried on the lower end by one of the upper pushers 16. Usually (following known criteria), the bodies 2 are held on the lower ends of the pushers 16 by suction means, not shown in the drawings.

Also following known criteria (which do not require description here), the pushers 16 may be able to move horizontally so that they can pick up the upper bodies 2 automatically from a supply, alignment and orientation structure (not shown).

Figures 3 to 6 illustrate the structure of the apparatus of the invention in greater detail with specific reference to one only of the chambers 11: it will be understood that the structure illustrated in Figures 3 to 6 is reproduced identically, or almost identically, in all the other chambers of the apparatus 10.

Each chamber 11 is constituted by a vertical-axis duct whose cross-section corresponds to the cross-section

of the containers 1 to be assembled (circular in the embodiment illustrated). In general, each chamber 11 includes an upper portion or section 17 and a lower portion or section 18, open to the upper pusher 16 and to the lower pusher 15 respectively.

As will be seen more clearly below, the lower portion 18 of the chamber 11 is able to contract radially so that, at rest, its cross-section is at least marginally smaller than the cross-section of the (circular) open ends of the bodies 2 and 3.

The apparatus 10, or at least the parts constituting the vertical-axis chamber 11, is usually made of a material (such as TEFLON) which is resilient as well as self-lubricating, easily cleaned and suitable for contact with food products.

If the structure of the lower portion 18 of the chamber 11 is examined in detail, it can be noted that it has a plurality of resiliently yielding tongues 20 integrally formed with the material defining the chamber 11 and equiangularly spaced around the periphery of the portion 18 itself, the tongues converging, in their unstressed or rest position, towards the inside of the chamber 11 but each being able to open resiliently towards the outside when a body, such as a body 3, moves upwardly through the chamber or duct 11. In any case, the lower end of each tongue 20 is substantially aligned with the cross circumference of the lower end of the chamber 11 while, in the unstressed condition, the upper end projects distinctly into the chamber 11. In this way, the inner edges of the various tongues 20 (for example six, each with an angular extent of around 60°) associated with each chamber 11 jointly define, in the unstressed condition shown in Figure 3, a lower portion 18 of the chamber 11 which, starting from a lower opening having the same cross-sectional shape as the apertures 14 in the trays 13, generally tapers upwards (in an approximately frustoconical shape in the embodiment illustrated).

The flexibility of the tongues 20 means that they offer flexible resistance, with the ability to widen, to any body passing upwardly through the chamber 11 (it will be seen that this is the case for the bodies 3).

This said, it is clear that the embodiment illustrated, while preferred at the moment, is only one possible variant of the solution of the invention.

In particular, the arrangement whereby at least one portion of the chamber 11 is able to contract radially being retained, it is possible to adopt functionally equivalent solutions to that described. For example, it would be possible to replace the tongues 20 by blades of high-quality, resilient steel or of another resiliently yielding material. Alternatively, it would be possible to replace each tongue 20 by an L-shaped body pivoted at its corner about a horizontal axis so that its main arm extends, overall, approximately along the axis of the chamber and its secondary arm extends radially from this axis away from the axis itself, the free end being acted on by resilient means which urge the L-shaped body into a rest position in which the side of the arm facing into the

chamber 11 projects into the chamber 11 itself in an arrangement similar to that of the tongues 20. It would also be possible, at least in principle, to form a portion of the chamber 11, such as the lower portion 18 of Figures 3 to 7, with a tubular body of resiliently yielding material whereby, when a body passes upwardly through this chamber 11, the wall of the chamber 11 or a part thereof, behaves substantially peristaltically.

Whatever arrangement is adopted, by controlling the pushers 15 and 16 to move simultaneously or virtually simultaneously (after the pushers have been aligned exactly with the row of apertures 14 holding the bodies 3), it is possible to insert the bodies 2 and 3 into the chambers 11. To be precise, the upper bodies 2 are transferred downwards by the pushers 16 which descend, pushing the bodies 2 into the upper portions 17 of the chambers 11, for example until the open end of each body 2 bears against the upper ends of the tongues 20 which project into each chamber 11. In a similar way, the pushers 15 lift the bodies 3 (which contain the surprises S and the sheets F) into the lower portion 18 (see the sequence illustrated in Figures 3 and 4).

As a result of the upward movement of the pushers 15, the bodies 3 (or to be precise the neck portions 4 through which portions of the surprises S and sheets F project upwardly) penetrate the lower portions 18 of the chambers 11 and start to force the tongues 20 apart (see Figure 4).

This opening action increases as the pushers 15 carry the bodies 3 upwards (Figure 5) causing the upper ends of the surprise components S and the sheets F gradually to penetrate the open end of the corresponding bodies 2.

This accurate insertion movement is possible (without problems such as the jamming of one of the components of the surprise S or, yet more frequently, of parts of the sheets F) thanks to the radial containing action of the resilient tongues 20 and, in general, thanks to the capacity of the lower portion 18 of each chamber 11 to contract radially.

In other words, during the movement (upwards) towards engagement inside the open end of the body 2, the sheets F and the components of the surprise S are radially contained by the tongues 20, which urge them towards the axis of the chamber 11. This ensures that, at the moment of engagement with the body 2, none of the elements in the body 3 project radially from the neck 4. This avoids any risk, even at rather high operating rates, of the bodies 2 and 3 jamming owing to the presence therein, especially in the lower body 3, of the elements (parts of the surprise S and sheets F).

The movement whereby the bodies 2 and 3 are coupled together can therefore continue until it is completed and the container 1 is assembled (Figure 6).

From observation of Figure 5, it will be appreciated that the completion of the movement whereby the container 1 is assembled corresponds to a precisely determined relative position (spacing) of the pusher members 15 and 16 along the axis of the chamber 11

(this being a function of the axial dimensions of the container 1).

By measuring this distance (with known means, for example by using optical sensors associated with the actuator assemblies of one or both of the pushers 15, 16 which are intended to cooperate with each other), it is possible to check the axial dimensions of the assembled container 1 in order to identify, and possibly discard, those containers that, for a variety of reasons, prove to have different axial dimensions from those required.

When the assembly operation is completed, the container 1 is inside the chamber 11 and can, for example, be returned to the tray 13 in which it was held before by a downward movement of the pusher members 15, 16 (Figure 6). Should this be desired, the container 1 may also be left for a moment inside the apparatus 10 (where it is held by the resilient action of the tongues 20) and discharged in a different position, possibly after the apparatus 10 as a whole has been moved by the action of additional pusher members.

The discharge of the assembled container 1 causes the tongues 20 to return resiliently to their unstressed condition of Figure 3 ready for a new assembly cycle, analogous to that described above.

For the sake of clarity, it should be noted that the movements of the various movable parts of the apparatus described above are controlled, according to the predetermined sequence described and illustrated thereafter, by an electronic control unit such as, for example, a programmable electronic controller or PLC (not illustrated). All the above accord with criteria which are widely known in the art and do not require extensive explanation here, particularly since they are not in themselves relevant to an understanding of the invention.

Claims

1. An apparatus for the assembly of containers comprising two generally cup-like bodies (2, 3) which fit together by engagement of their open ends, of which at least one body (3), at the time of assembly, contains elements (S, F) liable to project radially from its open end (4), including:

a structure defining a duct (11) in which the bodies (2, 3) can advance (15, 16) towards each other and pusher means for advancing the bodies into end-to-end engagement; the duct (11) comprising at least one portion (18) able to contract radially so that, at rest, its cross-section is at least marginally smaller than the outline of the open ends of the bodies (2, 3); and wherein the

pusher means (15, 16) advance the bodies (2, 3) into end-to-end engagement in the radially-contractible portion (18) whereby, during the engagement phase, the radially-contractible portion

- (18) of the duct (11) exerts a containing force on the elements (S, F) which are liable to project, ensuring that they are contained radially within the open ends (4) so that the open ends of the bodies (2, 3) can be engaged without interference from the elements (S, F). 5
2. An apparatus according to Claim 1, characterised in that it includes a holding structure (13) for at least one (3) of the two cup-like bodies (2, 3), characterised in that the pusher means (15) act on the at least one body (3) to expel it from the holding structure whereby the end-to-end engagement is achieved outside the holding structure (13). 10 15
 3. An apparatus according to Claim 2, characterised in that the holding structure is constituted by a tray (13) including a plurality of holding apertures (14) in a general matrix-like structure, each aperture being able to hold a respective at least one body (3). 20
 4. An apparatus according to Claim 1 or Claim 3, characterised in that it includes a plurality of said ducts (11) whereby a plurality of containers (1) may be formed simultaneously by the engagement of respective cup-like bodies (2, 3). 25
 5. An apparatus according to any one of the preceding Claims, characterised in that the axis of the duct (11) is vertical. 30
 6. An apparatus according to any one of the preceding Claims, characterised in that the radially contractible portion (18) is defined by a plurality of elements (20) movable between a rest position, in which the elements (20) project into the duct (11), and a position in which they are opened apart and into which they are urged by the force exerted on them by at least one (3) of the cup-like bodies. 35 40
 7. An apparatus according to Claim 6, characterised in that the movable elements (20) are resiliently yielding elements.
 8. An apparatus according to Claim 6 or Claim 7, characterised in that the movable elements (20) are equiangularly spaced around the perimeter of the duct (11). 45
 9. An apparatus according to any one of the preceding Claims, characterised in that the walls of the duct (11) are of a self-lubricating material. 50
 10. An apparatus according to any one of Claims 6 to 8, characterised in that the movable elements (20) are made integrally with the material forming the duct (11). 55
 11. A method for the assembly of containers comprising two generally cup-like bodies (2, 3) which fit together by engagement of their open ends, of which at least one (3) of the bodies, at the moment of assembly, contains elements (S, F) liable to project radially from its open end (4), including the steps of:
 - defining a duct (11) in which the bodies (2, 3) can advance (15, 16) towards each other to achieve the end-to-end engagement; the duct (11) having at least one portion (18) which is radially contractible so that, at rest, its cross-section is at least marginally smaller than the outline of the open ends of the bodies (2, 3); and
 - advancing (15, 16) the bodies (2, 3) into end-to-end engagement inside the radially-contractible portion (18) whereby, during the engagement phase, the radially-contractible portion (18) of the duct (11) exerts a containing force on the elements (S, F) which are liable to project thereby containing them radially within this open end and ensuring that the open ends of the bodies (2, 3) engage without interference from the elements (S, F).
 12. A method according to Claim 11, characterised in that it includes the step of providing a holding structure (13) for at least one (3) of the two cup-like bodies (2, 3) and the step of pushing (15) said at least one body (3) out of the holding structure (13) whereby the end-to-end engagement is achieved outside the holding structure (13).
 13. A method according to Claim 12, characterised in that the holding structure is formed as a tray (13) including a plurality of holding apertures (14) in a general matrix-like structure, each aperture being able to hold a respective at least one body (3).
 14. A method according to Claim 13, characterised in that a plurality of ducts (11) is provided whereby a plurality of containers (1) may be made simultaneously by the end-to-end engagement of respective cup-like bodies (2, 3).
 15. A method according to any one of the preceding Claims 11 to 14, characterised in that the duct (11) is arranged with its axis vertical.
 16. A method according to any one of the preceding Claims 11 to 15, characterised in that it includes the step of providing a plurality of elements (20) which define the radially-contractible portion (18) and are movable between a rest position, in which the elements (20) project into the duct (11) and a position in which they are opened apart and into which they are moved by the force exerted by at least one of the cup-like bodies (2, 3).

17. A method according to Claim 16, characterised in that the movable elements are constituted by resiliently yielding elements (20).
18. A method according to Claim 16 or Claim 17, characterised in that it includes the step of spacing the movable elements (20) equiangularly around the perimeter of the duct (11).
19. A method according to any one of the preceding Claims 11 to 13, characterised in that the duct (11) is made with walls of self-lubricating material.
20. A method according to any one of the Claims 16 to 18, characterised in that it includes the step of forming the movable elements (20) integrally with the material constituting the duct (11).

Patentansprüche

1. Vorrichtung für das Zusammensetzen von Behältern, die zwei im allgemeinen schalenförmige Körper (2, 3) besitzen, die durch das Eingreifen ihrer offenen Enden zusammenpassen, wobei zumindest ein Körper (3) zum Zeitpunkt des Zusammensetzens Teile (S, F) enthält, die dazu neigen, radial aus dem offenen Ende (4) herauszuragen, wobei die Vorrichtung einen Aufbau aufweist, der einen Kanal (11) bildet, in den sich die Körper (2, 3) aufeinander zu bewegen können, sowie eine Drückeinrichtung aufweist, um die Körper so vorzuschieben, daß sie mit ihren Enden in Eingriff treten, wobei der Kanal (11) zumindest einen Teil (18) enthält, der sich radial so zusammenziehen kann, daß sein Querschnitt im Ruhezustand zumindest ein wenig kleiner als der Umriß der offenen Enden der Körper (2, 3) ist; und wobei die Drückeinrichtung (15, 16) die Körper (2, 3) in einen Endeingriff im radial zusammenziehbaren Teil (18) vorschiebt, womit während der Eingreifphase der radial zusammenziehbare Teil (18) des Kanals (11) eine Rückhaltekraft auf die Teile (S,F) ausübt, die zum Herausragen neigen, wodurch sichergestellt wird, daß sie radial innerhalb der offenen Enden (4) zurückgehalten werden, so daß die offenen Enden der Körper (2, 3) in Eingriff gebracht werden können, ohne daß die Teile (S, F) dazwischentreten.
2. Vorrichtung gemäß Anspruch 1, dadurch gekennzeichnet, daß die Vorrichtung einen Tragaufbau (13) für zumindest einen (3) der beiden schalenförmigen Körper (2, 3) aufweist, dadurch gekennzeichnet, daß die Drückeinrichtung (15) auf den zumindest einen Körper (3) wirkt, um ihn aus dem Tragaufbau herauszudrücken, wodurch der Eingriff der Enden außerhalb des Tragaufbaus (13) erfolgt.
3. Vorrichtung gemäß Anspruch 2, dadurch gekennzeichnet, daß der Tragaufbau von einer Wanne (13) gebildet wird, die eine Vielzahl von Aufnahmeöffnungen (14) in einem im allgemeinen matrixartigen Aufbau enthält, wobei jede Öffnung zumindest einen Körper (3) aufnehmen kann.
4. Vorrichtung gemäß Anspruch 1 oder 3, dadurch gekennzeichnet, daß die Vorrichtung eine Vielzahl von Kanälen (11) aufweist, womit eine Vielzahl von Behältern (1) durch den Eingriff von entsprechenden schalenförmigen Körpern (2, 3) gleichzeitig hergestellt werden kann.
5. Vorrichtung gemäß irgendeinem der bisherigen Ansprüche, dadurch gekennzeichnet, daß die Achse des Kanals (11) vertikal verläuft.
6. Vorrichtung gemäß irgendeinem der bisherigen Ansprüche, dadurch gekennzeichnet, daß der radial zusammenziehbare Teil (18) von einer Vielzahl von Elementen (20) gebildet wird, die zwischen einer Ruhestellung, in der die Elemente (20) in den Kanal (11) vorspringen, und einer Stellung bewegbar sind, in der sie geöffnet sind, wobei sie durch jene Kraft in diese Stellung gedrückt werden, die der zumindest eine (3) der schalenförmigen Körper auf sie ausübt.
7. Vorrichtung gemäß Anspruch 6, dadurch gekennzeichnet, daß die bewegbaren Elemente (20) elastisch nachgebende Elemente sind.
8. Vorrichtung gemäß Anspruch 6 oder 7, dadurch gekennzeichnet, daß die bewegbaren Elemente (20) rund um den Umfang des Kanals (11) in gleichen Winkelabständen beabstandet sind.
9. Vorrichtung gemäß irgendeinem der bisherigen Ansprüche, dadurch gekennzeichnet, daß die Wände des Kanals (11) aus einem selbstschmierenden Material bestehen.
10. Verfahren gemäß irgendeinem der Ansprüche 6 bis 8, dadurch gekennzeichnet, daß die bewegbaren Elemente (20) gemeinsam mit jenem Material hergestellt werden, aus dem der Kanal (11) besteht.
11. Verfahren für das Zusammensetzen von Behältern, die zwei im allgemeinen schalenförmige Körper (2, 3) besitzen, die durch das Eingreifen ihrer offenen Enden zusammenpassen, wobei zumindest einer (3) der Körper zum Zeitpunkt des Zusammensetzens Teile (S, F) enthält, die dazu neigen, radial aus dem offenen Ende (4) herauszuragen, wobei das Verfahren folgende Schritte aufweist:
- Ausbilden eines Kanals (11), in dem sich die Körper (2, 3) aufeinander zu bewegen (15, 16) können, um den Endeingriff zu erreichen;

- Wobei der Kanal (11) zumindest einen Teil (18) enthält, der sich radial so zusammenziehen kann, daß sein Querschnitt im Ruhezustand zumindest ein wenig kleiner als der Umriß der offenen Enden der Körper (2, 3) ist; und
- Vorschieben (15, 16) der Körper (2, 3) in einen Eingriff im radial zusammenziehbaren Teil (18), womit während der Eingreifphase der radial zusammenziehbare Teil (18) des Kanals (11) eine Rückhaltekraft auf die Teile (S, F) ausübt, die zum Herausragen neigen, wodurch sie radial innerhalb dieses offenen Endes zurückgehalten werden, und wodurch sichergestellt wird, daß die offenen Enden der Körper (2, 3) in Eingriff gelangen, ohne daß die Teile (S, F) dazwischentreten.
12. Verfahren gemäß Anspruch 11, dadurch gekennzeichnet, daß das Verfahren einen Schritt, um einen Tragaufbau (13) für zumindest einen (3) der beiden schalenförmigen Körper (2, 3) zu liefern, sowie einen Schritt aufweist, um den zumindest einen Körper (3) aus dem Tragaufbau (13) herauszudrücken, wodurch der Eingriff der Enden außerhalb des Tragaufbaus (13) erfolgt.
13. Verfahren gemäß Anspruch 12, dadurch gekennzeichnet, daß der Tragaufbau von einer Wanne (13) gebildet wird, die eine Vielzahl von Aufnahmeöffnungen (14) in einem im allgemeinen matrixartigen Aufbau enthält, wobei jede Öffnung zumindest einen Körper (3) aufnehmen kann.
14. Verfahren gemäß Anspruch 13, dadurch gekennzeichnet, daß eine Vielzahl von Kanälen (11) vorgesehen ist, womit eine Vielzahl von Behältern (1) durch den Eingriff von entsprechenden schalenförmigen Körpern (2, 3) gleichzeitig hergestellt werden kann.
15. Verfahren gemäß irgendeinem der bisherigen Ansprüche 11 bis 14, dadurch gekennzeichnet, daß der Kanal (11) so angeordnet ist, daß seine Achse vertikal verläuft.
16. Verfahren gemäß irgendeinem der bisherigen Ansprüche 11 bis 15, dadurch gekennzeichnet, daß das Verfahren einen Schritt aufweist, um eine Vielzahl von Elementen (20) zu liefern, die den radial zusammenziehbaren Teil (18) bilden und zwischen einer Ruhestellung, in der die Elemente (20) in den Kanal (11) vorspringen, und einer Stellung bewegbar sind, in der sie geöffnet sind, wobei sie durch jene Kraft in diese Stellung gedrückt werden, die von zumindest einem schalenförmigen Körper (2, 3) ausgeübt wird.
17. Verfahren gemäß Anspruch 16, dadurch gekennzeichnet, daß die bewegbaren Elemente von ela-

stisch nachgebenden Elementen (20) gebildet werden.

18. Verfahren gemäß Anspruch 16 oder 17, dadurch gekennzeichnet, daß das Verfahren einen Schritt aufweist, um die bewegbaren Elemente (20) rund um den Umfang des Kanals (11) in gleichen Winkelabständen zu beabstanden.
19. Verfahren gemäß irgendeinem der bisherigen Ansprüche 11 bis 13, dadurch gekennzeichnet, daß der Kanal (11) mit Wänden aus einem selbstschmierenden Material hergestellt ist.
20. Verfahren gemäß irgendeinem der Ansprüche 16 bis 18, dadurch gekennzeichnet, daß das Verfahren einen Schritt aufweist, um die bewegbaren Elemente (20) gemeinsam mit jenem Material herzustellen, aus dem der Kanal (11) besteht.

Revendications

1. Dispositif pour l'assemblage de récipients comprenant deux corps ayant la forme générale de coques (2, 3) qui s'assemblent l'un à l'autre par emboîtement de leur extrémité ouverte, dont au moins un corps (3), au moment de l'assemblage, contient des éléments (S, F) susceptibles de faire saillie radialement à partir de son extrémité ouverte (4), comprenant

une structure définissant un conduit (11) dans lequel les corps (2, 3) peuvent avancer (15, 16) l'un vers l'autre et des moyens pousseurs pour avancer les corps en emboîtement bout à bout, le conduit (11) comprend au moins une portion (18) capable de se contracter radialement de sorte qu'au repos, sa section soit au moins marginalement plus petite que le contour des extrémités ouvertes des corps (2, 3); et dans lequel

les moyens pousseurs (15, 16) avancent les corps (2, 3) en emboîtement bout à bout dans la portion radialement contractile (18), ce qui, durant la phase d'emboîtement, permet à la portion radialement contractile (18) du conduit (11) d'exercer une force de maintien sur les éléments (S, F) qui sont susceptibles de faire saillie, garantissant leur maintien radialement à l'intérieur des extrémités ouvertes (4) de façon que les extrémités ouvertes des corps (2, 3) puissent s'emboîter sans interférence des éléments (S, F).

2. Dispositif selon la revendication 1, caractérisé en ce qu'il comprend une structure de support (13) pour au moins un (3) des deux corps en forme de coques (2, 3), caractérisé en ce que les moyens pousseurs (15) agissent sur l'au moins un corps (3)

- pour l'expulser de la structure de support, ce qui permet de réaliser l'emboîtement bout à bout à l'extérieur de la structure de support (13).
3. Dispositif selon la revendication 2, caractérisé en ce que la structure de support est constituée d'un plateau (13) comprenant une pluralité d'ouvertures de support (14) selon une structure ayant la forme générale d'une matrice, chaque ouverture étant capable de supporter au moins un corps respectif (3). 5
 4. Dispositif selon la revendication 1 ou la revendication 3, caractérisé en ce qu'il comprend une pluralité desdits conduits (11), ce qui permet de former simultanément une pluralité de récipients (1) par l'emboîtement des corps respectifs en forme de coques (2, 3). 10 15
 5. Dispositif selon l'une quelconque des revendications précédentes, caractérisé en ce que l'axe du conduit (11) est vertical. 20
 6. Dispositif selon l'une quelconque des revendications précédentes, caractérisé en ce que la portion radialement contractile (18) est définie par une pluralité d'éléments mobiles (20) entre une position de repos, dans laquelle les éléments (20) font saillie dans le conduit (11), et une position dans laquelle ils sont écartés et dans laquelle ils sont poussés par la force exercée sur eux par au moins un (3) des corps en forme de coques. 25 30
 7. Dispositif selon la revendication 6, caractérisé en ce que les éléments mobiles (20) sont des éléments cédant élastiquement. 35
 8. Dispositif selon la revendication 6 ou la revendication 7, caractérisé en ce que les éléments mobiles (20) sont espacés de façon équidistante autour du périmètre du conduit (11). 40
 9. Dispositif selon l'une quelconque des revendications précédentes, caractérisé en ce que les parois du conduit (11) sont en un matériau autolubrifiant. 45
 10. Dispositif selon l'une quelconque des revendications 6 à 8, caractérisé en ce que les éléments mobiles (20) sont formés d'une seule pièce avec le matériau formant le conduit (11). 50
 11. Procédé pour l'assemblage de récipients comprenant deux corps ayant la forme générale de coques (2, 3) qui s'assemblent l'un à l'autre par emboîtement de leur extrémité ouverte, dont au moins un (3) des corps, au moment de l'assemblage, contient des éléments (S, F) susceptibles de faire saillie radialement à partir de son extrémité ouverte (4), comprenant les étapes suivantes: 55
 - définition d'un conduit (11) dans lequel les corps (2, 3) peuvent avancer (15, 16) l'un vers l'autre pour réaliser l'emboîtement bout à bout; le conduit (11) ayant au moins une portion (18) qui est radialement contractile de façon que, au repos, sa section soit au moins marginalement plus petite que le contour des extrémités ouvertes des corps (2, 3); et
 - avancement (15, 16) des corps (2, 3) en emboîtement bout à bout à l'intérieur de la portion radialement contractile (18), ce qui, durant la phase d'engagement, permet à la portion radialement contractile (18) du conduit (11) d'exercer une force de maintien sur les éléments (S, F) qui sont susceptibles de faire saillie, les maintenant ainsi radialement à l'intérieur de cette extrémité ouverte et garantissant que les extrémités ouvertes des corps (2, 3) s'emboîtent sans interférence des éléments (S, F).
 12. Procédé selon la revendication 11, caractérisé en ce qu'il comprend l'étape de fourniture d'une structure de support (13) pour au moins un (3) des deux corps en forme de coques (2, 3) et l'étape de poussée (15) dudit au moins un corps (3) hors de la structure de support (13), ce qui permet de réaliser l'emboîtement bout à bout à l'extérieur de la structure de support (13).
 13. Procédé selon la revendication 12, caractérisé en ce que la structure de support est constituée d'un plateau (13) comprenant une pluralité d'ouvertures de support (14) selon une structure ayant la forme générale d'une matrice, chaque ouverture étant capable de supporter au moins un corps respectif (3).
 14. Procédé selon la revendication 13, caractérisé en ce qu'une pluralité de conduits (11) est fournie, ce qui permet de réaliser simultanément une pluralité de récipients (1) par emboîtement bout à bout de corps en forme de coques respectifs (2, 3).
 15. Procédé selon l'une quelconque des revendications précédentes 11 à 14, caractérisé en ce que le conduit (11) est disposé en ayant son axe orienté à la verticale.
 16. Procédé selon l'une quelconque des revendications précédentes 11 à 15, caractérisé en ce qu'il comprend l'étape de fourniture d'une pluralité d'éléments (20) qui définissent la portion radialement contractile (18) et sont mobiles entre une position de repos, dans laquelle les éléments (20) font saillie à l'intérieur du conduit (11), et une position dans laquelle ils sont écartés et dans laquelle ils sont déplacés par la force exercée par au moins un des corps en forme de coques (2, 3).

17. Procédé selon la revendication 16, caractérisé en ce que les éléments mobiles sont constitués par des éléments (20) cédant élastiquement.
18. Procédé selon la revendication 16 ou la revendication 17, caractérisé en ce qu'il comprend l'étape d'espacement des éléments mobiles (20) de façon équidistante sur tout le périmètre du conduit (11). 5
19. Procédé selon l'une quelconque des revendications précédentes 11 à 13, caractérisé en ce que le conduit (11) est réalisé avec des parois en matériau autolubrifiant. 10
20. Procédé selon l'une quelconque des revendications 16 à 18, caractérisé en ce qu'il comprend l'étape de formation des éléments mobiles (20) d'une seule pièce avec le matériau constituant le conduit (11). 15

20

25

30

35

40

45

50

55

FIG. 1

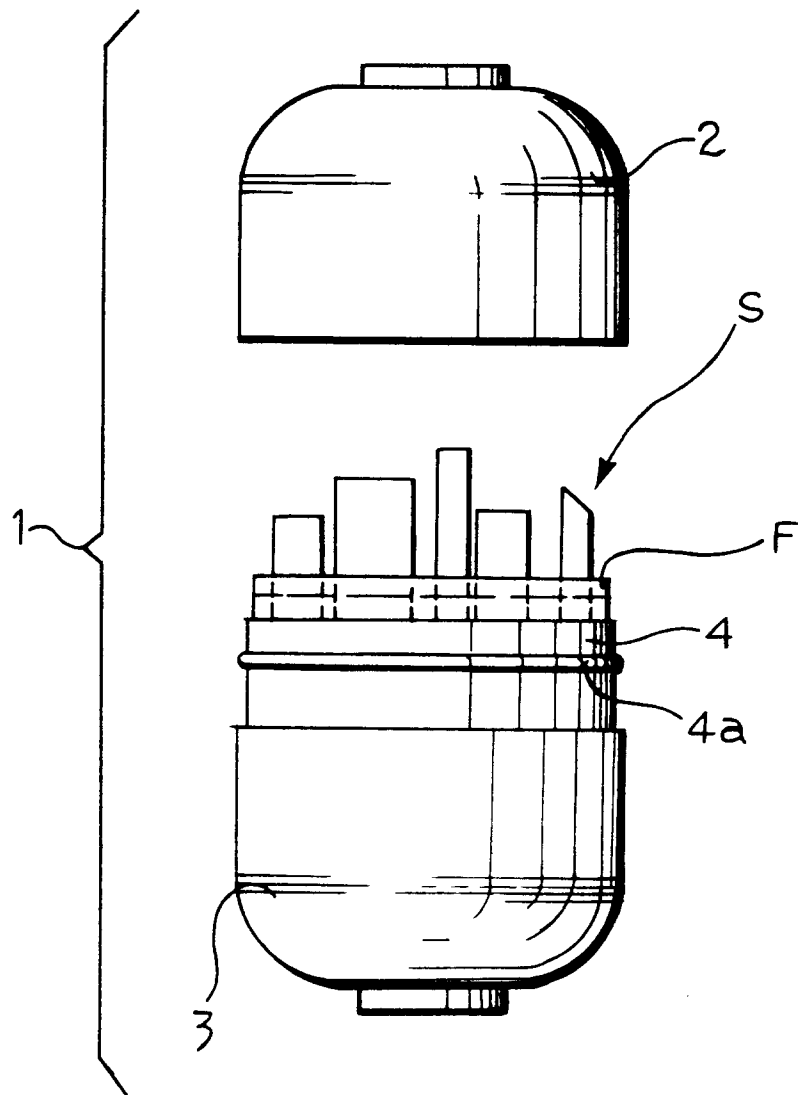

FIG. 4

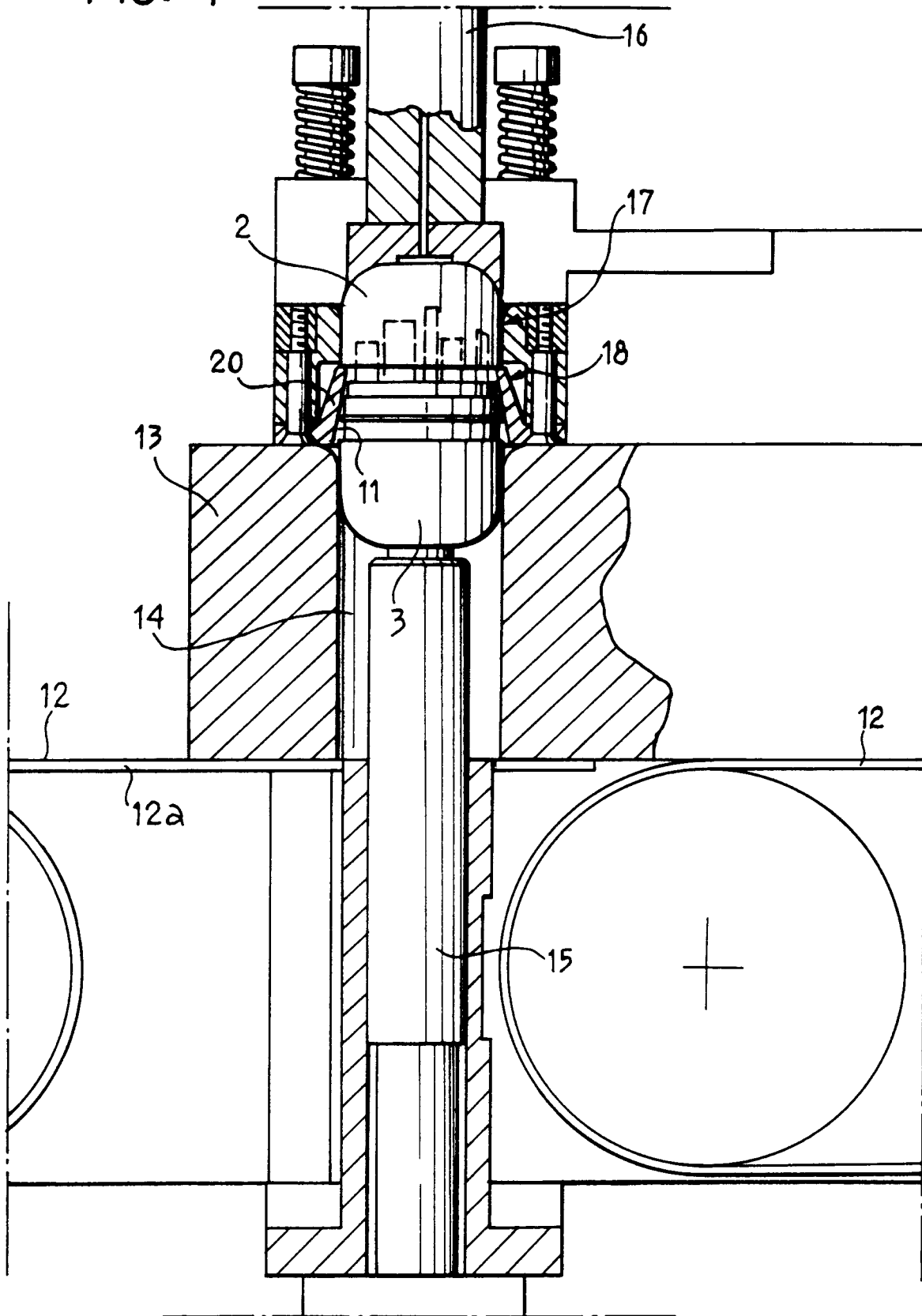

FIG. 5

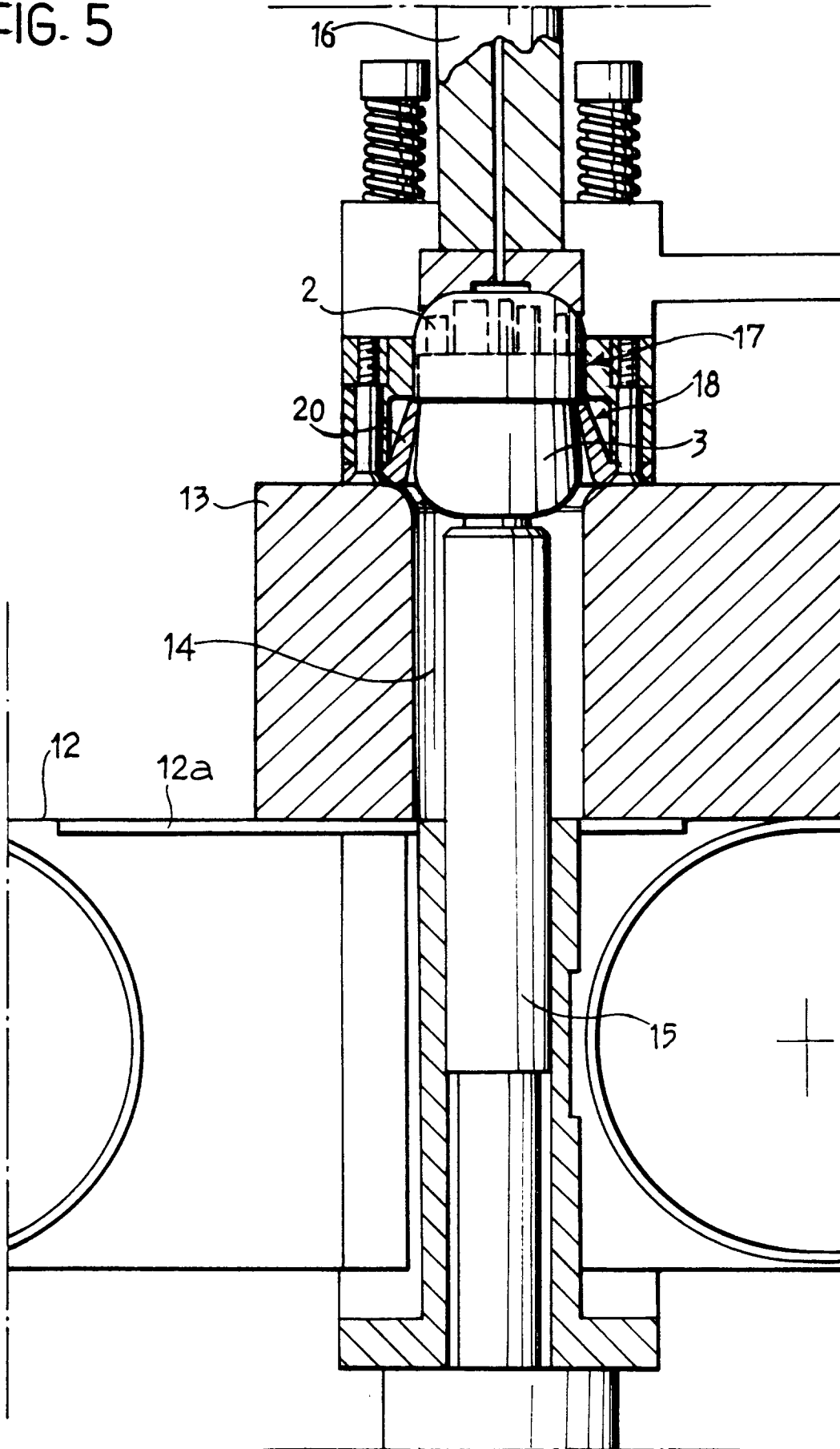

FIG. 6

