

(19) World Intellectual Property Organization
International Bureau



(43) International Publication Date
6 April 2006 (06.04.2006)

PCT

(10) International Publication Number
WO 2006/037085 A2

(51) International Patent Classification:
B41M 5/00 (2006.01)

(74) Agent: **HOLMES, Stephen, J.**; Barlow, Josephs & Holmes, Ltd., 101 Dyer Street, 5th floor, Providence, RI 02903 (US).

(21) International Application Number:
PCT/US2005/034964

(81) Designated States (*unless otherwise indicated, for every kind of national protection available*): AE, AG, AL, AM, AT, AU, AZ, BA, BB, BG, BR, BW, BY, BZ, CA, CH, CN, CO, CR, CU, CZ, DE, DK, DM, DZ, EC, EE, EG, ES, FI, GB, GD, GE, GH, GM, HR, HU, ID, IL, IN, IS, JP, KE, KG, KM, KP, KR, KZ, LC, LK, LR, LS, LT, LU, LV, LY, MA, MD, MG, MK, MN, MW, MX, MZ, NA, NG, NI, NO, NZ, OM, PG, PH, PL, PT, RO, RU, SC, SD, SE, SG, SK, SL, SM, SY, TJ, TM, TN, TR, TT, TZ, UA, UG, US, UZ, VC, VN, YU, ZA, ZM, ZW.

(22) International Filing Date:
27 September 2005 (27.09.2005)

(25) Filing Language: English

(26) Publication Language: English

(30) Priority Data:
60/613,575 27 September 2004 (27.09.2004) US

(84) Designated States (*unless otherwise indicated, for every kind of regional protection available*): ARIPO (BW, GH, GM, KE, LS, MW, MZ, NA, SD, SL, SZ, TZ, UG, ZM, ZW), Eurasian (AM, AZ, BY, KG, KZ, MD, RU, TJ, TM), European (AT, BE, BG, CH, CY, CZ, DE, DK, EE, ES, FI, FR, GB, GR, HU, IE, IS, IT, LT, LU, LV, MC, NL, PL, PT, RO, SE, SI, SK, TR), OAPI (BF, BJ, CF, CG, CI, CM, GA, GN, GQ, GW, ML, MR, NE, SN, TD, TG).

(71) Applicant (*for all designated States except US*): **ARK-WRIGHT, INC. A Rhode Island corporation** [US/US]; 538 Main Street, Fiskeville, RI 02823 (US).

(72) Inventors: **KLOULTCHAEV, Khizyr, K.**; 17 Barker Place, Branford, CT 06405 (US). **HO, Cau The**; 65 Russo Avenue, Unit I-3, East Haven, CT 06531 (US). **XU, Zhong**; 285 Plantation Street, Ap. 117, Worcester, MA 01604 (US). **CONFORTI, Robert, M.**; 89 Day Lily Circle, Wakefield, RI 02879 (US).

Published:
— *without international search report and to be republished upon receipt of that report*

[Continued on next page]

(54) Title: INK-JET MEDIA HAVING AN INK-VEHICLE PERMEABLE COATING AND A MICROPOROUS COATING

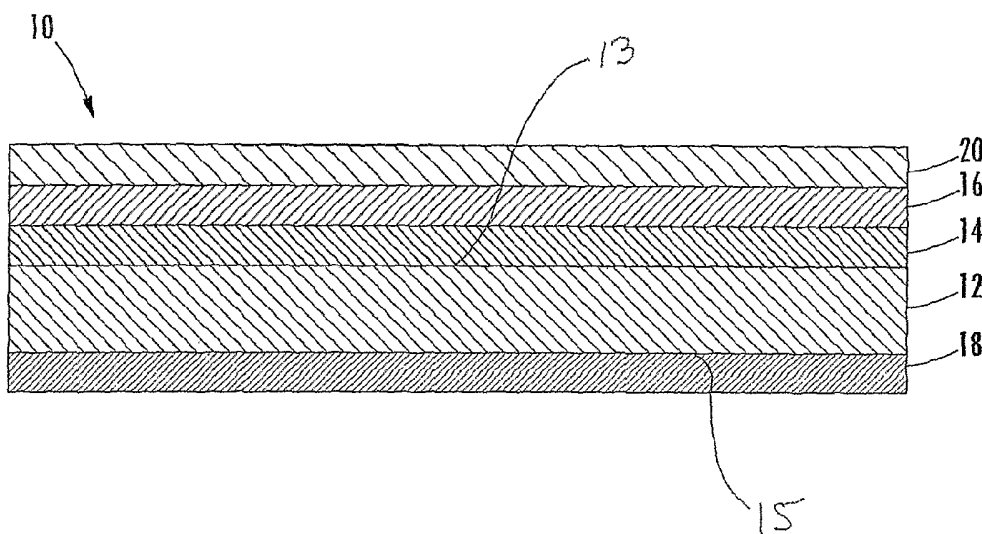

(57) Abstract: An ink jet media (10, 100) having an absorbent substrate (12) with a front surface (13) and a back surface (15). The front surface (13) of the substrate (12) is coated with an ink-vehicle permeable, preferably radiation-cured, coating (14). A microporous ink-receptive coating (16) is deposited on top of the ink-vehicle permeable coating (14). An optional protective layer (20) may be deposited on top of the microporous ink-receptive layer (16). The back surface (15) of the substrate (12) may also be optionally coated with a polymer curl-controlling coating (18).

WO 2006/037085 A2



For two-letter codes and other abbreviations, refer to the "Guidance Notes on Codes and Abbreviations" appearing at the beginning of each regular issue of the PCT Gazette.

INK-JET MEDIA HAVING AN INK-VEHICLE PERMEABLE COATING AND
A MICROPOROUS COATING

1 **Cross-Reference to Related Application:**

2 This application claims the benefit under 34 U.S.C. § 119(e) to U.S.
3 Provisional Patent Application Serial No. 60/613,575 filed September 27, 2004, the
4 contents of which are incorporated herein by reference.

5
6 **Background of the Invention:**

7 The present invention is directed to ink-jet printable media and more
8 specifically to ink-jet printable media having an absorptive substrate, a ink-vehicle
9 permeable coating, which may have been radiation cured, overlying the substrate and
10 a microporous ink-receptive coating overlying the ink-vehicle permeable coating.

11 Ink-jet printing systems are highly effective for producing colored images on
12 various substrates, such as papers, films, and other imaging media, that can be used in
13 different applications. For example, ink-jet printed media have found many
14 commercial uses for indoor and outdoor signage, posters, bulletins, advertising
15 banners, and the like where vendors are looking to provide colorful graphic displays.
16 Modern ink-jet printing systems employ various digital technologies, inks, and ink-jet
17 printers to produce high-quality printed images on the imaging media.

18 In a typical ink-jet recording or printing system, ink droplets are ejected from
19 a nozzle at high speed toward an imaging media to produce an image. The ink
20 droplets generally comprise a recording agent, such as a dye or pigment, and a liquid
21 vehicle. The vehicle can be made up of water, an organic material such as an alcohol
22 and various other additives.

23 Inks used in ink-jet printers can be dye-based, pigment-based or a
24 combination. In dye-based inks, the colorant (dye) is molecularly dispersed or
25 solvated by a carrier medium. In pigment-based inks, the colorant exists as discrete
26 particles. Some inks comprise both pigments and dyes.

27 The ink-jet imaging media generally comprises a substrate and an ink-
28 receptive layer formed on an imaging surface of the substrate. The substrate can be
29 selected from a wide variety of materials such as papers, films, non-woven webs,

1 metal foils, and the like. This substrate is then coated with specially formulated ink-
2 receptive compositions that are capable of receiving and holding the aqueous-based
3 inks effectively so as to generate a quality printed image. Various surface finishes,
4 such as matte, satin and gloss finishes can be achieved by proper selection of suitable
5 substrate materials and coating compositions.

6 While the earliest forms of ink-jet media were a significant improvement
7 over the use of plain paper, the ink-jet media industry has continuously strived to
8 develop coated ink-jet media products capable of recording printed images having
9 improved color brilliance, resolution, and density as well as other desirable properties.
10 For example, one goal is to provide ink-jet media that resists fading of the ink under
11 high ozone conditions. Ozone-fade resistance is a particularly desirable feature for
12 ink-jet imaging media used in outdoor applications.

13 Generally speaking, all ink-jet imaging media should be capable of absorbing
14 the ink quickly so that the printed image dries instantaneously or within a very short
15 period of time but yet should have good water-resistance (i.e., the printed image
16 should have good resistance to being smeared or rubbed off when the image is
17 wetted.) Another common industry objective is to provide imaging media having at
18 least a satin, and preferably, a glossy surface finish.

19 In recent years, the ink-jet industry has attempted to address the need for
20 imaging media having improved print properties by developing ink-receptive coatings
21 that commonly are referred to as "microporous" ink-receptive coatings. These
22 microporous ink-receptive coatings contain particles and polymer binders. The
23 particle and polymer binder materials, in combination, provide the ink-receptive
24 coating with a microporous morphology that can better absorb aqueous inks.

25 Although ink-jet imaging media coated with microporous ink-receptive
26 coatings have some advantageous properties and can effectively record high-quality
27 images, in certain instances, some of these products can also have certain drawbacks.

28 Cracking of the microporous coating is one issue. For example, where a
29 relatively high surface gloss, i.e. a gloss reading of 40 or more, is desired, it is often
30 required to deposit a relatively thick layer of the microporous coating onto the
31 underlying substrate (such as a paper substrate with a matte surface). The thick
32 microporous coating will adequately receive the inks to form the printed image, but it

1 is prone to developing small cracks during the manufacturing process. These coatings
2 are typically applied to rolls of a substrate traveling in a continuous coating process.
3 The substrate is coated and then passed through a drying tunnel to dry the coating
4 before the next coating process. Thicker coatings require longer drying times, longer
5 drying ovens and thus more manufacturing time and expense. Accelerating the drying
6 process to reduce costs and manufacturing time tends to cause the coating to crack.

7 Thick coatings of the microporous material can also cause a change in color
8 hue of the printed image. In some instances, composite colors contained in the printed
9 image, which are produced by certain inks, do not appear as the intended color on the
10 microporous coated layer. For instance, cyan (C), magenta (M), and yellow (Y) inks
11 may be selected and applied to the medium in order to produce a composite black
12 color, but the actual printed color may be a dark blue. It is believed that multiple
13 scattering of the light within the microporous coating causes this color shift.

14 Finally, cost is another issue. The microporous coating materials are
15 relatively expensive, and applying thick coats of the microporous material is
16 expensive, driving up the price of these coated media.

17 It has been suggested that a radiation-cured polymer barrier coating, applied
18 to the base substrate beneath the microporous coating, can lead to a glossy medium.
19 See US Patent No. 6610388. However, because that radiation-cured coating forms a
20 moisture barrier and thus is not permeable, the aqueous ink vehicle must be absorbed
21 entirely within the microporous top coating. The microporous coating in that
22 configuration does not need to be very thick to provide gloss, but it still needs to be
23 thick enough to absorb all the aqueous ink vehicle. Accordingly, there is a trade-off
24 between reducing the thickness of the microporous coating material enough to reduce
25 its cost and cracking during manufacture, on the one hand, and increasing it to achieve
26 good gloss and good drying characteristics, on the other.

27 There is thus a continuing need in the industry for improved ink-jet imaging
28 media that has a relatively high gloss and superior printing characteristics, but yet
29 does not require the application of a thick microporous ink-receptive layer.
30
31
32

1 **Summary of the Invention:**

2 The present invention provides ink-jet media having such improved print
3 performance properties.

4 The present invention seeks to solve the drawbacks encountered with the use
5 of microporous ink-receptive coatings by providing an ink-jet medium having an ink-
6 vehicle permeable, preferably radiation-cured coating underlying the microporous
7 coating. In particular, the ink-jet medium of the present invention comprises an
8 absorbent substrate having a front surface and a back surface, an ink-vehicle
9 permeable, preferably radiation-cured, coating overlying the front surface of the
10 substrate, and a microporous ink-receptive coating overlying the ink-vehicle
11 permeable, preferably radiation-cured, coating.

12 An optional outer protective coating may overlie the microporous coating.
13 The back surface of the substrate may also include a polymer curl-controlling coating.

14 The absorbent substrate preferably comprises a paper substrate, such as a
15 clay-coated paper. However, other absorbent substrates, such as synthetic fiber sheets,
16 and porous polymer sheets also are contemplated, as well as composite substrate
17 materials comprising a non-porous substrate with an absorptive layer coated on its
18 surface.

19 A radiation-curable coating is preferably an ultraviolet (UV) curable
20 oligomer or monomer, preferably acrylate-based, that is cured to afford a sufficiently
21 ink-vehicle permeable coating to permit the ink vehicle to penetrate in a controlled
22 manner through to the absorptive substrate. This permeability is a key feature of the
23 invention. In contrast, prior art radiation-cured and other barrier coatings functioned
24 as moisture barriers, preventing the absorption of the ink vehicle in the substrate.
25 Further, coating layers that have had only a minor bulk effect on the permeation of
26 vehicle from a microporous or other ink absorptive coating to an underlying
27 absorptive substrate as defined herein, are not permeable in the meaning of this
28 invention. As discussed later, the effect of the permeability can be determined by a
29 Cobb test with the basic liquid constituent of the ink vehicle of the ink for which the
30 medium is manufactured.

1 The microporous ink-receptive layer comprises a porous dispersion of
2 particles and a polymer binder that quickly absorbs ink, but exhibits improved color
3 brilliance, sharpness and fidelity.

4 The unique combination of the ink vehicle-permeable, preferably radiation-
5 cured, substrate coating and the microporous ink-receptive layer cooperate to provide
6 media with good gloss and ink drying characteristics with a thinner microporous layer
7 than would be required in the absence of the permeable coating over an absorptive
8 substrate. It may be improved further with an additional coating over the microporous
9 layer.

10 Accordingly, among the objects of the present invention are: the provision of
11 ink-jet media having superior print performance properties; the provision of ink-jet
12 media having a glossy surface finish; the provision of ink-jet media that does not
13 exhibit surface cracking; the provision of ink-jet media that includes a permeable,
14 preferably radiation-cured, coating and a microporous coating that work in
15 combination to provide the media with improved ink drying times with reduced
16 microporous coating thickness with high gloss.

17 Other objects, features and advantages of the invention shall become
18 apparent as the description thereof proceeds when considered in connection with the
19 accompanying illustrative drawings.

20

21 **Description of the Drawings:**

22 In the drawings which illustrate the best modes presently contemplated for
23 carrying out the present invention:

24 FIG. 1 is a schematic cross-sectional view of the preferred embodiment of
25 the ink-jet media of the present invention;

26 FIG. 2 is a schematic cross-sectional view of an alternative embodiment of
27 the ink-jet media of the present invention; and

28 FIGS. 3A-3D are graphic depictions of Cobb test data comparing ink-vehicle
29 barrier coated substrates with ink-vehicle permeable coated substrates.

30

31

1 **Description of the Preferred Embodiment:**

2 Referring to Fig. 1, the ink-jet recording media of the present invention is
3 shown generally at 10. As will be described in greater detail below, the ink jet
4 recording media of the present invention 10 comprises an absorbent substrate 12, an
5 ink-vehicle permeable, preferably radiation-cured coating 14 overlying a front or
6 imaging surface 13 of the substrate, and a microporous ink-receptive coating 16
7 overlying the permeable coating 14.

8 An optional, curl-control coating 18 can be applied to the back surface 15 of
9 the substrate 12 to help reduce curling and cockling of the media 10. Additionally, a
10 protective layer 20 may be applied over the microporous ink-receptive coating 16 to
11 help reduce ozone-fading problems. Optionally, coating 18 can be replaced with
12 coating construction 14, 16 and 20 overlying surface 15 to produce a symmetrical
13 medium that can be used without regard to "sidedness".

14

15 **A. Substrate**

16 Absorbent substrates 12 are well known in the printing industry, and can
17 include a variety of different types of papers, boards and composite materials. In this
18 regard, in the context of the present invention, the substrate 12 preferably comprises a
19 paper substrate, and more preferably comprises a clay-coated paper. Plain papers,
20 coated papers, treated papers, paperboard that is treated or untreated, synthetic fiber
21 papers, and non-woven papers are also suitable for purposes of the present invention
22 so long as they are absorbent alone or with an absorptive coating. Foam core board
23 material is also a suitable substrate.

24 The substrate 12 may also be pre-treated with an adhesion promoter to enhance
25 adhesion of the coating 14 to the substrate.

26 Substrate 12 with a range of glosses can be used in the context of the present
27 invention, as the permeable coating 14 will provide the base on which a glossy surface
28 can be achieved. Accordingly, less expensive matte and satin finish paper substrates
29 can be used as a substrate for the media of the present invention.

30 Referring briefly to Fig. 2, an alternative embodiment of the invention is
31 illustrated and generally indicated at 100. The alternative embodiment 100 includes
32 an alternative composite substrate 112, which comprises a non-absorptive backing

1 sheet 112A, and an absorptive layer 112B. The permeable, preferably radiation-cured,
2 coating 14, and microporous top coating 16 are the same as their counterparts in Fig.
3 1, and have the same chemical compositions to be described hereinafter.

4 In this regard, the non-porous backing sheet 112A, preferably comprises a
5 polymeric film such as, for example, polyethylene, polypropylene, polyester,
6 naphthalate, polycarbonates, polysulfone, polyether sulfone, poly(arylene sulfone),
7 cellulose triacetate, cellophane, polyvinyl chloride, polyvinyl fluoride, polyimides,
8 polystyrene, polyacrylics, polyacetals, ionomers, and mixtures thereof. In other
9 instances, a metal foil such as aluminum foil or a metal-coated material can be used as
10 the backing sheet 112A.

11 To provide the substrate 112 with an absorbent surface, an absorbent layer
12 112B is applied to the non-absorptive backing sheet 112A. The coating 112B of this
13 invention may be prepared from a coating formulation comprising one or a blend of
14 ink-vehicle absorptive polymers, preferably from the group comprising an acrylic
15 polymer, and acrylic copolymer, poly(vinyl pyrrolidone) (PVP), poly(2-ethyl-2-
16 oxazoline) (PEOX), polyvinyl alcohol and carboxyalkyl cellulose and their variants in
17 degree of substitution, hydrolysis, molecular weight and nature of the substituents.
18 Here, alkyl means preferable methyl, ethyl and propyl, but is not limited to these and
19 may be a combination, such as methyl, ethyl carboxycellulose. The acrylic
20 copolymer, PVP, and PEOX are film-forming materials. The acrylic copolymer may
21 be selected from such polymers as, for example, styrene acrylics (available under the
22 tradenames of Joncryl 624 and Joncryl HPD-71 from Johnson Polymers). In one
23 embodiment, a blend comprising an acrylic copolymer having a relatively low Tg and
24 PVP is used. Particularly, a blend comprising an acrylic copolymer having a Tg of
25 less than 25°C, and PVP can be used. For example, the acrylic copolymer, Joncryl
26 624 has a relatively low glass transition temperature (Tg) of about -30°C. The acrylic
27 copolymer is typically present in the coating in an amount of about 60% to about 90%,
28 and the PVP is present in an amount of about 10% to about 40% based on dry weight
29 of the coating. It has been found that the combination of the Joncryl 624 material and
30 the PVP provides a strong and durable substrate coating 112B which effectively
31 supports the radiation-curable coating 14 and microporous top coat 16.

32 In another embodiment of the coating 112B, a blend comprising an acrylic

1 copolymer having a relatively low Tg; an acrylic copolymer having a relatively high
2 Tg; and PVP is used. For example, an acrylic copolymer having a Tg of less than
3 25°C may be used in combination with an acrylic copolymer having a Tg of greater
4 than 25°C. The acrylic copolymer having the relatively low Tg is typically present in
5 the coating in an amount of about 20% to about 60%, the acrylic copolymer having
6 the relatively high Tg is typically present in the coating in the amount of about 10% to
7 about 40%, and the PVP is typically present in the coating in the amount of about 20%
8 to about 40% based on dry weight of the coating. The acrylic copolymer, Joncryl
9 HPD-71 has a Tg of about 128°C. It has been found that the combination of the
10 Joncryl 624 and Joncryl HPD-71 materials and the PVP provides a coating having
11 high mechanical strength at high drying temperatures.

12 In addition, it has been found that an acrylic copolymer or blend of acrylic
13 copolymers having a relatively high acid functionality also provides the coating with
14 beneficial properties. For example, it may be desirable to use an acrylic copolymer
15 having an acid functionality of at least 25. Here, acid functionality and acid number
16 are used interchangeably and have the conventional meaning that it is the number of
17 milligrams of KOH required to reach equivalence (neutralize in the case of a strong
18 acid) with one gram of the acid-containing material. The Joncryl 624 material has an
19 acid number of 50, and the Joncryl HPD-71 material has an acid number of 214. It is
20 believed that acrylic copolymers having a high acid functionality provide the coating
21 with good absorptivity. The moisture sensitivity of the coating may be controlled and
22 enhanced by using these high acid acrylic copolymers in combination with the PVP.

23 The coating 112B may also contain additives such as inhibitors, surfactants,
24 waxes, plasticizers, cross-linking agents, dye fixatives, de-foaming agents, pigments,
25 dispersing agents, optical brighteners, UV light stabilizers (blockers), UV absorbers,
26 adhesion promoters, gel-promoters, such as sodium tetraborate-decahydrate, and the
27 like.

28

29 **B. Water Permeable, Radiation-Cured Coating**

30 The ink-vehicle permeable, preferably radiation-cured, coating 14 of the
31 present invention overlies the front surface 13 of the substrate 12 and enables the
32 medium 10 to achieve a glossy surface finish without a very thick microporous layer.

1 However, unlike the prior art barrier chemistries, which sealed the front surface of the
2 substrate and prevented the ink vehicle (such as water) from penetrating into the
3 substrate, the present vehicle permeable layer allows the ink vehicle to permeate
4 through the coating 14 into the underlying absorbent substrate 12. As will be
5 explained further hereinafter, the permeable nature of this internal coating 14 is a key
6 feature of the invention both in the context of manufacturing and in the context of end
7 use.

8 The permeable layer of this invention can work in combination with the
9 microporous ink-receptive layer to provide an improved ink-jet media having a high
10 gloss as well as significantly improved ink absorption and drying time. The
11 microporous ink-receptive layer used to make the ink-jet imaging media of this
12 invention is described further below. Despite being somewhat permeable, the
13 preferably radiation-cured layer of this invention makes it possible to achieve high
14 surface gloss of the medium.

15 The coating 14 is identified as being permeable. One of its roles is to control
16 the rate of permeation on the ink vehicle to the absorptive substrate. Another is to
17 provide a base on which a relatively thin microporous layer can be applied to produce
18 a medium with good drying and high gloss characteristics. A preferred way to
19 produce this permeable coating layer is to apply a radiation curable coating, preferably
20 acrylate-based, then radiation cure the radiation curable coating wholly or partially.
21 The preferred form of radiation for this is ultra-violet (UV) light curing. However,
22 other radiation curing technologies, such as x-ray or electron-beam curing, as well as
23 other methods of forming permeable coatings with the appropriate permeability also
24 can be used within the scope of the invention. During manufacture of the media, a
25 radiation-curable composition is applied to the substrate and, thereafter, radiation
26 from an electron beam, x-ray source or ultraviolet (UV) light source is used to cure
27 this radiation-curable coating. In ultraviolet (UV) light radiation, photoinitiators
28 (photosensitizers) typically are used to initiate the polymerization.

29 In the present invention, the radiation-cured coating 14 preferably is produced
30 from a curable coating that comprises acrylate-based oligomers or monomers or a
31 combination of them, and it can comprise urethane-modified acrylic monomers, or
32 hydroxyl-terminated urethane oligomers, for example.

1 Preferably, in the present invention, UV light radiation is used to cure the
2 coating, and in this regard the coating formulation preferably includes a photoinitiator.

3 The coating may also contain additives such as inhibitors, surfactants, waxes, cure
4 accelerators, defoaming agents, pigments, dispersing agents, optical brighteners, UV
5 light stabilizers (blockers), UV absorbers, adhesion promoters, and the like.

6 In the manufacturing process, one or more UV-curable oligomers and or
7 monomers are blended together with a photoinitiator and any additives. The mixture
8 may be heated to reduce its viscosity. The coating formulation may be applied to the
9 substrate 12 by any suitable method. Suitable methods for application of the
10 monomers and/or oligomers (leading to coating 14) to the paper substrate 12 include,
11 for example, Meyer-rod, roller, blade, wire bar, dip, solution extrusion, air-knife,
12 curtain, slide, doctor-knife, and gravure methods. The vehicle-permeable radiation-
13 cured coating 14 preferably has a coating weight between about 2g/m^2 and about
14 10g/m^2 , and most preferably a coating weight of about 5g/m^2 .

15 Typically, the UV light has a wavelength in the range of about 150 nm to
16 about 400 nm. Commercial UV light curing equipment may be used. Such equipment
17 typically includes an UV light source (e.g., a tubular glass lamp), reflectors to focus or
18 diffuse the UV light, and a cooling system to remove heat from the lamp area. After
19 the curing steps, the UV-cured coating 14 may be treated with corona discharge to
20 improve its adhesion to the microporous ink-receptive coating 16 to be applied over
21 the coating 14.

22 23 **C. Microporous Ink-Receptive Layer**

24 The microporous ink-receptive coating 16 can be applied over the freshly
25 irradiated ink-vehicle permeable coating 14. Generally, the microporous ink-receptive
26 coating 16 comprises a dispersion of particles (pigment) and a polymer binder. The
27 particle and polymer binder materials provide the ink-receptive layer with a porous
28 morphology that enables the ink-receptive layer to better absorb the ink vehicle, such
29 as water. The particles in the composition can form interstitial pores or voids in the
30 ink-receptive coating 16 so that the coating 16 can absorb the ink by a wicking or
31 capillary action. As ink is impinged onto the coating, it enters these interstitial voids
32 and is absorbed. The dyes and/or pigments of the ink can be retained in the

1 microporous layer. Some of the ink vehicle can pass through the permeable layer 14
2 into the absorptive substrate or absorptive layer on the substrate. This effectively
3 increases the ink vehicle absorptivity of the microporous layer without increasing or
4 requiring an increase in its thickness. The blend of particle and polymer binders in the
5 ink-receptive layer significantly contributes to the relatively fast ink-drying times of
6 the media.

7 The particles can comprise inorganic or organic particles. Suitable inorganic
8 particles that can be used in the ink-receptive layer include, for example, those
9 selected from the group consisting of kaolin, talc, clay, calcium sulfate, calcium
10 carbonate, alumina, aluminum silicate, colloidal alumina, silica, colloidal silica,
11 lithopone, zeolite, hydrated halloysite, magnesium hydroxide, magnesium carbonate,
12 barium sulfate, titanium dioxide, zinc oxide, zinc sulfate, and zinc carbonate particles.
13 These particles can be in the form of aerogels and/or xerogels as well as amorphous or
14 crystalline materials. Suitable organic polymer particles include, for example, those
15 selected from the group consisting of polyethylene, polypropylene, polyacrylate,
16 polymethacrylate, polystyrene, polyamide, polyurethane, fluoropolymer, and polyester
17 particles. The particles, themselves, can have a high surface area and porous structure.
18 Such porous particles can absorb the aqueous ink vehicle themselves in addition to
19 forming open voids in the ink-receptive layer.

20 In the present invention, the ink-receptive layer preferably is highly-loaded
21 with particles. The porous ink-receptive layer typically includes about 70 to about 95
22 percent by weight and preferably 87 to 94 percent by weight of particles based on dry
23 weight of the ink-receptive layer.

24 The binder resin used in the porous ink-receptive layer forms a film-like
25 coating that anchors the particles in place, and provides cohesion and mechanical
26 integrity to the porous ink-receptive layer. The binder material is generally water-
27 soluble and includes, for example, materials selected from the group consisting of
28 polyvinyl alcohols (PVAs); modified polyvinyl alcohols (e.g., carboxyl-modified
29 PVA, silicone-modified PVA, maleic acid-modified PVA, and itaconic acid-modified
30 PVA); poly(vinyl pyrrolidone); vinyl pyrrolidone copolymers; poly(2-ethyl-2-
31 oxazoline); poly(ethylene oxide); poly(ethylene glycol); poly(acrylic acids); starch;
32 modified starch (e.g., oxidized starch, cationic starch, hydroxypropyl starch, and

1 hydroxyethyl starch), cellulosic polymers oxidized cellulose, cellulose ethers,
2 cellulose esters, methyl cellulose, hydroxyethyl cellulose, carboxymethyl-cellulose,
3 benzyl cellulose, phenyl cellulose, hydroxypropyl cellulose, ethyl hydroxyethyl
4 cellulose, hydroxyethyl methyl cellulose, hydroxypropyl methyl cellulose, hydroxy
5 butylmethyl cellulose, dihydroxypropyl cellulose, hydroxypropyl hydroxyethyl
6 cellulose, chlorodeoxycellulose, aminodeoxycellulose, diethylammonium chloride
7 hydroxyethyl cellulose, and hydroxypropyl trimethyl ammonium chloride
8 hydroxyethyl cellulose); alginates and water-soluble gums; dextrans; carrageenan;
9 xanthan; chitin; proteins; gelatins; agar; and mixtures thereof.

10 In addition, the porous ink-receptive layer 16 may contain additives such as pigments,
11 surface active agents that control the wetting or spreading action of the coating as it is
12 applied to the substrate, anti-static agents, suspending agents, acidic compounds to
13 control the pH of the coating, optical brighteners, defoamers, humectants, waxes,
14 plasticizers, and the like.

15 The above-described coating techniques such as Meyer rod, roller, blade, wire
16 bar, dip, die-extrusion, air knife, curtain, slide, doctor knife and gravure also can be
17 used to apply the microporous ink-receptive coating 16 in accordance with this
18 invention. In manufacture, the microporous ink-receptive coating is applied over the
19 ink-vehicle permeable, preferably radiation-cured coating 14. The microporous
20 coating 16 is preferably applied with a coating weight between about 8g/m^2 and about
21 38g/m^2 , more preferably with a coating weight between about 18g/m^2 and about
22 32g/m^2 , and most preferably with a coating weight of about 25g/m^2 .

23 The coated substrate is placed in an oven to dry the microporous ink-receptive
24 coating. As discussed in the summary, because the microporous coating 16 is not
25 thick, the coating 16 can be effectively dried in a short period of time, possibly at a
26 higher temperature, with decreased attendant risk of cracking the coating during
27 drying.

28 After the porous ink-receptive layer has been dried, a top protective layer may
29 be applied over the porous ink-receptive layer as described further below.

30
31
32

1 **D. Protective Layer**

2 A relatively thin protective coating 20 may be applied over the microporous
3 ink-receptive coating 16 in accordance with this invention. The protective coating 20
4 helps to protect the printed image from environmental conditions. For example, the
5 protective coating may provide resistance to ozone fading of the printed image on the
6 medium. With this protective coating, the ink-jet media may be capable of recording
7 images that will resist fading due to ozone exposure. The ozone-protective coating
8 may slow the photo-oxidation process, which is one of the primary causes for ozone-
9 fading problems. The resins used in this protective coating must be capable of
10 providing the final ink-jet media with good ozone fading resistance, but also must be
11 capable of providing the media (in combination with the above-described radiation-
12 cured and porous ink-receptive layers) with good water-resistance, a glossy surface
13 finish, and very favorable ink dry time. Some resins are not suitable for use in the
14 protective layer in accordance with the present invention. For instance, those resins
15 that provide good ozone fading resistance but adversely affect image dry time or water
16 resistance significantly would not be suitable. Preferably, the protective layer should
17 help to reduce color hue shifts, which are associated with imaging some microporous
18 layers, as mentioned above.

19 While a number of materials can provide such a protective coating, the
20 preferred composition used to prepare the protective coating 20 in this invention is an
21 aqueous solution comprising polyethylene oxide and a cellulosic polymer.

22 The polyethylene oxide used to prepare the protective layer is water-soluble.
23 Suitable polyethylene oxide resins are commercially available such as PolyOx® from
24 the Dow Chemical Company. The polyethylene oxide polymers should have a high
25 molecular weight (at least 1000000 Daltons). Very tight molecular weight distribution
26 is also preferred. A water-soluble derivative of methyl cellulose is used to prepare the
27 ozone-protective layer in accordance with this invention. One example of a suitable
28 derivative of methyl cellulose is hydroxy propyl methyl cellulose (Methocel®)
29 available from the Dow Chemical Company. Higher molecular weight Methocel®
30 products having tight molecular weight distributions are preferred for used in the
31 protective coating.

32 Silica and other inorganic or organic particles may be added to the formulation.

1

E. Coating of Back Surface of Substrate

2
3 In addition, the back surface 15 of the substrate 12 may be coated with a
4 polymeric coating 18 that further helps prevent moisture from penetrating into the
5 back surface 15 of the substrate 12. The polymeric coating 18 on the back surface of
6 the substrate enhances the substrate's dimensional stability and helps minimize
7 curling, cockling, and other defects. Applying the back coating 18 also provides a way
8 to adjust the back surface-friction of the medium, which can be important in assisting
9 the feeding of the imaging medium into the ink-jet printer, and typically also provides
10 a way to control the anti-static properties to the ink-jet medium.

11

F. Advantageous Properties

12
13 The resulting ink-jet media 10 and 100 produced in accordance with this
14 invention have many desirable properties and offer several improvements over
15 conventional ink-jet media. Particularly, the permeable, preferably radiation-cured,
16 coating 14 and microporous ink-receptive coating 16 cooperate to provide the media
17 with a highly desirable glossy surface finish without the application of a thick
18 microporous coating. The microporous coating and ink vehicle permeable coating
19 also cooperate to provide improved ink drying times and good water-resistance after
20 printing so that the printed image is less likely to smear or rub-off when the image is
21 wetted. The thinner microporous coating also provides high quality prints having high
22 color brilliance, sharpness, and fidelity. The thinner microporous coating is also
23 effective for providing a medium that is substantially free of cracks.

24

G. In-Line Continuous Manufacturing Process:

25
26 The present invention also encompasses a continuous, in-line process for
27 making the ink-jet imaging medium. In general, the process comprises the steps of: a)
28 applying the radiation-curable coating to the surface of the substrate; b) irradiating the
29 radiation-curable coating so that the coating undergoes a curing process; and c)
30 applying the porous ink-receptive coating over the freshly irradiated coating. As an
31 option, the above-described protective coating can be applied over the microporous
32 ink-receptive coating as another step in this in-line process.

1
2 **H. Examples**

3 Some examples of the ink-jet imaging media of this invention are illustrated
4 below. These examples should not be construed as limiting the scope of the invention.

5 In the following examples, percentages are by weight based on the weight of
6 the coating formulation, unless otherwise indicated.

7
8 **Radiation-Cured Coatings**

9 **EXAMPLE 1**

Trade Name	Supplier	Chemistry	% Weight
CD 9038	Sartomer	Ethoxylated Bisphenol A Diacrylate	66
CN 2400	Sartomer	Metallic acrylate	25
SR 706	Sartomer	Modified Metallic acrylate	2
Darocur MBF	Ciba	Benzeneacetic acid, .alpha.-oxo-, methyl ester	5
BFD1149/QFD1180	Sun Chemicals	Organic pigment dye dispersion blend	2

10
11 **EXAMPLE 2**

Trade Name	Supplier	Chemistry	% Weight
SR 399	Sartomer	Dipentaerythritol Pentaacrylate	37
LR 8765	BASF	Unsaturated Acrylic Resin	30
SR 610	Sartomer	Polyethylene Glycol (600) Diacrylate	30
Darocur MBF	Ciba	Benzeneacetic acid, .alpha.-oxo-, methyl ester	3

12
13 **EXAMPLE 3**

Trade Name	Supplier	Chemistry	% Weight
CN 2256	Sartomer	Polyester Acrylate Oligomer	10
CN 132	Sartomer	Aliphatic Diacrylate Oligomer	53
Darocur MBF	Ciba	Benzeneacetic acid, .alpha.-oxo-, methyl ester	2
Dispal 14N4-80	---	Aluminum hydroxide dispersion	25
Water	---	H2O	10

1 EXAMPLE 4

Trade Name	Supplier	Chemistry	% Weight
CN 2256	Sartomer	Polyester Acrylate Oligomer	33.5
SR 9016	Sartomer	Zinc Diacrylate	25
SR 9035	Sartomer	Ethoxylated (15) Trimethylolpropane Triacrylate	5
Darocur MBF	Ciba	Benzeneacetic acid, .alpha.-oxo-, methyl ester	3
Water	---	H2O	33.5

2

3

4

5

6

7

8

9

In each of the above Examples 1-4, the radiation-curable coatings were applied to the front surface 13 of a paper substrate (Glossy Cover Stock from Garda Cartiere or high sized, clay-coated base paper available from P.H. Glatfelter, Inc.). The coating was applied to the paper substrate using a "zero size" Meyer rod. Then, the coating was cured by a UV light source system.

Microporous Ink-Receptive Coatings

10

EXAMPLE 5

Trade Name	Supplier	Chemistry	% Weight
Poval 235	Kuraray	Polyvinyl alcohol	10.3
Dispal 14N4-80	Sasol	Aluminum hydroxide dispersion	89
BYK 380	Byk-Chemie	Fluorinated acrylic	0.1
Glyoxal	Aldrich	Glyoxal	0.5
Chemcor 540C25	Chemcor	PE emulsion	0.1

11

12

13

14

15

16

The above-described ink-receptive coating in Example 5 was applied over each radiation-cured layer described in above Examples 1-4 using a Meyer #52 rod. The ink-receptive coating was dried in a convection oven for 3 minutes at 100 degrees C.

EXAMPLE 6

Trade Name	Supplier	Chemistry	% Weight
Poval 245	Kuraray	Polyvinyl alcohol	7.8
Dispal 14N4-80	Sasol	Aluminum hydroxide dispersion	92
BYK 380	Byk-Chemie	Fluorinated acrylic	0.1
Chemcor 540C25	Chemcor	PE emulsion	0.1

1 The above-described ink-receptive coating in Example 6 was applied over
 2 each radiation-cured layer described in above Examples 1-4 using a Meyer #52 rod.
 3 The ink-receptive coating was dried in a convection oven for 3 minutes at 100 degrees
 4 C.

5

6 **COMPARATIVE EXAMPLE 1**

7 In this comparative example, the following radiation-curable coating
 8 formulation was prepared.

Chemical code	Supplier	Wt%	Chemistry
PUR 145	Polymer Systems	41	Aliphatic polyester based urethane
SR 610	Sartomer	50	Polyol Acrylate
Uvitex NFW LQ	Ciba	5	--
Darocur MBF	Ciba	4	Photoinitiator

9

10 **COMPARATIVE EXAMPLE 2**

11 In this comparative example, the following radiation-curable coating
 12 formulation was prepared.

Chemical code	Supplier	Wt%	Chemistry
CN 991	Sartomer	55	Aliphatic polyester based urethane
CN 2273	Sartomer	20	Polyester Acrylate
CN 132	Sartomer	20	Aliphatic diacrylate
KIP 100F	Sartomer	5	Photoinitiator

13

14 The radiation-curable coatings, as described in the above comparative
 15 examples, were applied to a paper substrate in the manner as described in the above
 16 Examples 1-4.

17

18

19 **COMPARATIVE EXAMPLE 3**

20 In this comparative example, the following swellable ink-receptive coating
 21 formulation was prepared.

22

Ingredient	Parts	Chemistry	Supplier
Water	66.5		
Methocel E-15	6	Hydroxy Propyl Methyl Cellulose	Dow
Dispal 23N4-20	23	Alumina Dispersion	Sasol
Witcobond 213	4.5	Polyurethane emulsion	Crompton
Zirconyl Chloride	0.5	Zirconium Oxychloride	Aldrich
BYK 380	0.5	Fluorine modified acrylic BYK	Chemie

1
2 The above-described ink-receptive coating in Comparative Example 3 was
3 applied over the permeable radiation-cured layer described in above Example 1 using
4 a Meyer #16 rod. The ink-receptive coating was dried in a convection oven for 3
5 minutes at 100 degrees C.

6
7 TABLE 1

Coating Combination	UV Cured Formulation	Microporous Formulation	Surface Gloss @ 60 degrees	Image Quality	Water Fastness	Image Dry Time	Comments
1	No coating	Example 5	18	4	5	4	Low Gloss
2	Example 1	Example 5	45	5	5	5	
3	Comp. Exam. 2	Example 5	42	2	3	2	Intercolor Bleed
4	Comp. Exam. 1	Example 5	37	3	4	5	Coating Cracking
5	Example 1	Comp. Exam. 3	80	4	1	2	No Water Fastness

8
9 Table 1 is a comparison of various properties of final ink-jet media products
10 based on different coating combinations. A clay-coated paper was used as the base
11 substrate in all coating combinations. Images were made using a Epson 820 Stylus
12 Photo Printer.

13 Ratings: The printed media were evaluated on a relative scale of 0 to 5, where
14 a rating of 5 means the printed medium has the best overall properties.

15 Properties of the printed media, which were prepared using different coating
16 combinations are presented in the above Table 1.

17
18 Combination 1

19 Product represented as Combination 1 does not have a UV radiation-cured

1 layer. The major disadvantage of this product is its low surface gloss. Printed images
2 dry fairly quickly; however, image quality is not the highest because of the low
3 reflection of the light from the surface.

4
5 Combination 2

6 Combination 2 is the best representative example of the invention. The printed
7 product has the highest print quality attributes and surface gloss. Printed images dry
8 immediately after being discharged from the printer. Combination 2 has very good
9 water splash-resistance.

10

11 Combination 3

12 Combination 3 contains a UV radiation-cured layer that acts as a moisture
13 barrier preventing penetration of water (ink vehicle) into the paper substrate.
14 Therefore, the absorption power of the base paper is not being utilized to
15 accommodate the ink volume. As the result, the printed image exhibits inter-color
16 bleeding and takes a longer time to dry.

17

18 Combination 4

19 Combination 4 represents a different coating combination to Combination 3.
20 The UV cured formulation of Combination 4 absorbs ink (water) too rapidly. This has
21 an effect on the drying of the microporous coating layer and can lead to cracks in the
22 microporous coating layer. Cracks reduce the surface gloss and cause printed image
23 defects, particularly dyes migrate along the cracks creating "feather" like inter-color
24 bleed patterns.

25 Combination 5

26 Combination 5 includes the ink-receptive coating of comparative example 3,
27 which is not water-resistant. Printed images made on this sample can be easily
28 smeared or completely destroyed if water is spilled onto the image.

29

30

31

32

1 TABLE 2

Coating Combination	UV Cured Formulation	Microporous Formulation	Microporous Coat Weight	Surface Gloss @ 60 degrees	Crack Rating	Print Quality
6	Comp. Exam. 2	Example 5	25 g/m ²	48	5	Poor
7	Comp. Exam. 2	Example 5	40 g/m ²	46	3	Excellent
8	None	Example 5	25 g/m ²	17	4	Marginal
9	None	Example 5	40 g/m ²	17	4	Good
10*	Example 1	Example 5	25 g/m ²	48	5	Excellent
11	Example 1	Example 5	40 g/m ²	44	4	Excellent

2
3 Table 2 is a comparison of various print, cracking, and gloss properties of final
4 ink-jet media products based on different coating combinations with an emphasis on
5 showing differences in gloss and water absorption stemming from the use of ink-
6 vehicle permeable, preferably radiation-cured coatings versus ink-vehicle barrier,
7 preferably radiation cured coatings, and the coating thickness of the microporous
8 layer. A clay-coated paper was used as the base substrate in all coating combinations.
9 Images were made using a Epson 820 Stylus Photo Printer.

10 Gloss Ratings

11 Gloss of the coated products can be compared to the maximum achievable
12 gloss for that particular microporous formulation. For the specific formulations
13 disclosed in the criteria, gloss ratings can be classified as follows:
14

15 High Gloss - any reading above 80% of the maximum achievable
16 gloss, i.e. above 40 @ 60 degrees angle if 50% reflection is taken as a maximum;

17 Moderate Gloss - readings between 50-80% of the maximum, i.e.
18 readings between 25 to 40; and

19 Low Gloss - any reading below 50% of the maximum, i.e. below 25.

20 (Micro-TRI-gloss meter marketed by BYK-Gardner used to evaluate surface
21 gloss.)

22
23
24

1 Crack Rating:

2 Cracking manifests itself as gloss reduction of the final product. Also it causes
3 image imperfections like inter-color ink bleeding known in the industry as "feathering",
4 where the volume of ink of one color rapidly spreads out along the star shaped
5 "channels" to the adjacent area of the other color causing a print defect. The criteria
6 for the degree of cracking are based on visual inspection of the image surface of the
7 coated substrates. For testing, a black square of 10cm by 10cm is printed on the final
8 product and examined under an optical microscope at 5x magnification. The number
9 of cracks in the printed area is counted and a rating assigned depending on the number
10 of cracks detected. The rating system is as follows:

11 5 - Crack Free - The coating is considered as crack free if no defects are found
12 on the 100 cm² printed area;

13 4 - Sample with 1-5 defects

14 3 - Sample with 6-10 defects

15 2 - Sample with 11-15 defects

16 1 - Sample with 16 or more defects.

17

18 Combinations 6 and 7

19 Combinations 6 and 7 each include a ink-vehicle barrier UV-cured coating.
20 Combination 6 has a thinner (25 g/m²) coat weight while Combination 7 has a thicker
21 (40 g/m²) coat weight. The thinner microporous coating in Combination 6 provided a
22 better crack rating (better drying), but exhibited poor print quality when combined
23 with the UV-cured barrier coating (ink absorption stops at the barrier and is limited to
24 the thinner microporous coating). The thicker microporous coating in Combination 7
25 exhibited better print quality, but a poor crack rating. Gloss was relatively equal
26 because both include a UV-cured coating.

27

28 Combinations 8 and 9

29 Combinations 8 and 9 do not include any radiation-cured coating.
30 Accordingly, both products had a lower gloss. The crack ratings were also similar, and
31 both exhibited poor to marginal print quality.

32

1 Combinations 10 and 11 (Combination 10 is most representative of the present
2 invention.)

3
4 Combinations 10 and 11 each included the ink-vehicle permeable, preferably
5 UV-cured coating of the present invention. Combination 10 has the thinner
6 microporous (25 g/m^2) coat weight while Combination 11 has the thicker microporous
7 (40 g/m^2) coat weight. Both Combinations 10 and 11 had a relatively similar gloss.
8 Combination 10 had a better crack rating than Combination 11. Again, the thinner
9 microporous coating weight is more suitable to drying without cracking. Both
10 Combinations 10 and 11 exhibited excellent print quality, emphasizing that the
11 preferred embodiment of Combination 10 exhibits the same, if not superior, printing
12 characteristics using a thinner microporous coating (1/3 thinner).

13
14 A comparison of Combinations 6 and 10 also illustrates the significant
15 difference in print quality when using the ink-vehicle permeable, preferably UV-cured
16 coating as opposed to the ink-vehicle barrier, preferably UV-cured coating. The print
17 quality of Combination 6 is identified as poor while the print quality of Combination
18 10 is identified as excellent. The key difference is the ability of the media product in
19 Combination 10 to more effectively absorb the ink by permeating through the
20 permeable UV-cured coating.

21 Turning to Figs. 3A-3D, the base paper (square - ■), base paper plus
22 permeable coating of Example 1 (star - *), along with coating combination 6 (triangle
23 - ▲), coating combination 9 (cross - x) and coating combination 10 (diamond - ◆),
24 were tested for water absorption using a standard TAPPI Cobb test (water absorption
25 of sized paper and paperboard T-441).

26 A standard TAPPI Cobb test was performed on all samples in order to evaluate
27 water absorption capacity of the substrates coated with radiation-cured and
28 microporous coatings. The numbers reported in the Cobb tests are the weight of the
29 absorbed water per square meter of the sample for a given time period. Series of tests
30 with data points at various time increments were performed on each sample, and the
31 amount of water absorbed was plotted against the test time.

32 The purpose of the Cobb test is to provide a quantifiable difference in media

1 products having a water-barrier coating as opposed to a water-permeable coating. Fig.
2 3A is a shorter 40 minute time frame, Fig. 3B is a longer 200 minute time frame, Fig.
3 3C is yet a longer 800 minute time frame, and Fig. 3D is an even longer 1200 minute
4 time frame. All of the paper-based samples exhibit initial water absorption within the
5 first few minutes, and then separate themselves based on differing absorption rates.
6 The key comparison is between coating combinations 6 (triangle - ▲) and 10
7 (diamond - ◆), and is best seen in the shorter time period illustrated in Fig. 3A.
8 Combination 6 (triangle - ▲) UV-cured barrier plus microporous coating exhibits a
9 flat or nearly zero (0) slope (no ongoing absorption) within the graph period after the
10 initial uptake, identifying that water is not being absorbed into the base paper, whereas
11 Combination 10 (diamond - ◆) UV-cured permeable plus microporous coating
12 exhibits a positive slope (slow absorption) within the graph period after the initial
13 uptake, identifying that water is slowly permeating through the permeable UV-cured
14 coating. Looking at the sample data, it is apparent that all three samples including the
15 25 g/m^2 microporous coating exhibit an initial water uptake of about 20 g/m^2 and
16 confirms that the microporous coating itself is absorbing water. However, the UV-
17 cured barrier coating in Combination 6 prevents any further water absorption into the
18 base paper. In contrast, the permeable UV-cured coating permits a controlled
19 absorption of water through the coating into the base paper substrate. Looking out
20 further in time (Fig. 3B), the water absorption of the base paper (square - ■) and
21 Combination 10 (diamond - ◆) eventually meet at about 180 minutes. Looking out in
22 time even further (approximately 800 minutes), the water absorption of Combination
23 6 (diamond - ◆) eventually exceeds that of the base paper alone by about 25 g/m^2 .
24 This leads us to the conclusion that the absorption of the base paper alone is about 80
25 g/m^2 , and that about 20 g/m^2 of absorption is attributable to the microporous coating
26 while an additional 5 g/m^2 of absorption is attributable to the permeable UV-cured
27 coating.

28 The Cobb test slope is defined as the slope over a test range of 3 to 30 minutes
29 of the best-fit straight line of the plot of the data of absorbed water (g/m^2) versus the
30 time at which the Cobb measurements were made.

31 It would be appreciated by those skilled in the art that various changes and
32 modifications can be made to the illustrated embodiments without departing from the

1 spirit of the present invention. All such modifications and changes are intended to be
2 within the scope of the present invention except as limited by the scope of the
3 appended claims.
4

1 **What is claimed is:**

- 2 1. An ink-jet printable medium, comprising:
3 an absorbent substrate having a front surface and a back surface;
4 an ink-vehicle permeable coating overlying the front surface of the substrate;
5 and
6 a microporous ink-receptive coating overlying the ink-vehicle permeable
7 coating.
8
9 2. The medium of claim 1 further comprising a polymeric curl-controlling
10 coating overlying the back surface of the substrate.
11
12 3. The medium of claim 1, further comprising a protective coating overlying the
13 microporous ink-receptive coating.
14
15 4. The medium of claim 1, wherein the substrate is selected from the group
16 consisting of paper substrates, polymer substrates, synthetic fiber substrates, and
17 composite substrates having a backing sheet and an absorbent coating overlying the
18 backing sheet.
19
20 5. The medium of claim 1 having a surface gloss of at least 35% measured at 60
21 degrees.
22
23 6. The medium of claim 1 wherein said ink-vehicle permeable coating is applied
24 with a coating weight between about 2g/m^2 and about 10g/m^2 .
25
26 7. The medium of claim 6 wherein said ink-vehicle permeable coating is applied
27 with a coating weight of about 5g/m^2 .
28
29 8. The medium of claim 1 wherein said microporous ink-receptive coating is
30 applied with a coating weight between about 8g/m^2 and about 38g/m^2 .
31
32

1 9. The medium of claim 8 wherein said microporous ink-receptive coating is
2 applied with a coating weight between about 18g/m^2 and about 32g/m^2 .

3

4 10. The medium of claim 1 wherein said microporous ink-receptive coating is
5 applied with a coating weight of about 25g/m^2 .

6

7 11. The medium of claim 1 wherein an acrylate-based material is contained in said
8 ink-vehicle permeable coating.

9

10 12. The medium of claim 1 wherein said ink-vehicle permeable coating comprises
11 a radiation-cured coating.

12

13 13. The medium of claim 12 wherein an acrylate-based material is contained in
14 said radiation-cured, ink-vehicle permeable coating.

15

16 14. The medium of claim 1 wherein said microporous ink-receptive layer
17 comprises a dispersion of particles and a polymer binder.

18

19 15. The medium of claim 1 having a Cobb absorption slope of greater than zero
20 ($0\text{g/m}^2/\text{min}$) within in a test range of about 3 minutes to about 30 minutes.

21

22 16. The medium of claim 12 having a Cobb absorption slope of greater than 0.05
23 $\text{g/m}^2/\text{min}$ within in a test range of about 3 minutes to about 30 minutes.

24

25 17. The medium of claim 16 having a Cobb absorption slope of greater than 0.1
26 $\text{g/m}^2/\text{min}$ within in a test range of about 3 minutes to about 30 minutes.

27

28 18. The medium of claim 17 having a Cobb absorption slope of greater than 0.2
29 $\text{g/m}^2/\text{min}$ within in a test range of about 3 minutes to about 30 minutes.

30

31 19. The medium of claim 18 having a Cobb absorption slope of greater than 0.5
32 $\text{g/m}^2/\text{min}$ within in a test range of about 3 minutes to about 30 minutes.

1

2 20. The medium of claim 1 having a Cobb absorption slope of about $0.8 \text{ g/m}^2/\text{min}$
3 within in a test range of about 3 minutes to about 30 minutes.

4

5 21. The medium of claim 1 having a Cobb absorption slope of between about 0.05
6 $\text{g/m}^2/\text{min}$ and about $1.0 \text{ g/m}^2/\text{min}$ within in a test range of about 3 minutes to about 30
7 minutes.

8

9 22. The medium of claim 4 having a Cobb absorption slope of greater than zero
10 $(0) \text{ g/m}^2/\text{min}$ within in a test range of about 3 minutes to about 30 minutes.

11

12 23. The medium of claim 22 having a Cobb absorption slope of greater than 0.05
13 $\text{g/m}^2/\text{min}$ within in a test range of about 3 minutes to about 30 minutes.

14

15 24. The medium of claim 23 having a Cobb absorption slope of greater than 0.1
16 $\text{g/m}^2/\text{min}$ within in a test range of about 3 minutes to about 30 minutes.

17

18 25. The medium of claim 24 having a Cobb absorption slope of greater than 0.2
19 $\text{g/m}^2/\text{min}$ within in a test range of about 3 minutes to about 30 minutes.

20

21 26. The medium of claim 25 having a Cobb absorption slope of greater than 0.5
22 $\text{g/m}^2/\text{min}$ within in a test range of about 3 minutes to about 30 minutes.

23

24 27. The medium of claim 4 having a Cobb absorption slope of about $0.8 \text{ g/m}^2/\text{min}$
25 within in a test range of about 3 minutes to about 30 minutes.

26

27 28. The medium of claim 4 having a Cobb absorption slope of between about 0.05
28 $\text{g/m}^2/\text{min}$ and about $1.0 \text{ g/m}^2/\text{min}$ within in a test range of about 3 minutes to about 30
29 minutes.

30

31 29. The medium of claim 5 having a Cobb absorption slope of greater than zero
32 $(0) \text{ g/m}^2/\text{min}$ within in a test range of about 3 minutes to about 30 minutes.

1

2 30. The medium of claim 29 having a Cobb absorption slope of greater than 0.05
3 $\text{g/m}^2/\text{min}$ within in a test range of about 3 minutes to about 30 minutes.

4

5 31. The medium of claim 30 having a Cobb absorption slope of greater than 0.1
6 $\text{g/m}^2/\text{min}$ within in a test range of about 3 minutes to about 30 minutes.

7

8 32. The medium of claim 31 having a Cobb absorption slope of greater than 0.2
9 $\text{g/m}^2/\text{min}$ within in a test range of about 3 minutes to about 30 minutes.

10

11 33. The medium of claim 32 having a Cobb absorption slope of greater than 0.5
12 $\text{g/m}^2/\text{min}$ within in a test range of about 3 minutes to about 30 minutes.

13

14 34. The medium of claim 5 having a Cobb absorption slope of about 0.8 $\text{g/m}^2/\text{min}$
15 within in a test range of about 3 minutes to about 30 minutes.

16

17 35. The medium of claim 5 having a Cobb absorption slope of between about 0.05
18 $\text{g/m}^2/\text{min}$ and about 1.0 $\text{g/m}^2/\text{min}$ within in a test range of about 3 minutes to about 30
19 minutes.

20

21 36. The medium of claim 11 having a Cobb absorption slope of greater than zero
22 (0) $\text{g/m}^2/\text{min}$ within in a test range of about 3 minutes to about 30 minutes.

23

24 37. The medium of claim 36 having a Cobb absorption slope of greater than 0.05
25 $\text{g/m}^2/\text{min}$ within in a test range of about 3 minutes to about 30 minutes.

26

27 38. The medium of claim 37 having a Cobb absorption slope of greater than 0.1
28 $\text{g/m}^2/\text{min}$ within in a test range of about 3 minutes to about 30 minutes.

29

30 39. The medium of claim 38 having a Cobb absorption slope of greater than 0.2
31 $\text{g/m}^2/\text{min}$ within in a test range of about 3 minutes to about 30 minutes.

32

1 40. The medium of claim 39 having a Cobb absorption slope of greater than 0.5
2 g/m²/min within in a test range of about 3 minutes to about 30 minutes.

3

4 41. The medium of claim 11 having a Cobb absorption slope of about 0.8
5 g/m²/min within in a test range of about 3 minutes to about 30 minutes.

6

7 42. The medium of claim 11 having a Cobb absorption slope of between about
8 0.05 g/m²/min and about 1.0 g/m²/min within in a test range of about 3 minutes to
9 about 30 minutes.

10

11 43. The medium of claim 5 wherein an acrylate-based material is contained in said
12 ink-vehicle permeable coating.

13

14 44. The medium of claim 43 having a Cobb absorption slope of greater than zero
15 (0) g/m²/min within in a test range of about 3 minutes to about 30 minutes.

16

17 45. The medium of claim 44 having a Cobb absorption slope of greater than 0.05
18 g/m²/min within in a test range of about 3 minutes to about 30 minutes.

19

20

21 46. The medium of claim 45 having a Cobb absorption slope of greater than 0.1
22 g/m²/min within in a test range of about 3 minutes to about 30 minutes.

23

24 47. The medium of claim 46 having a Cobb absorption slope of greater than 0.2
25 g/m²/min within in a test range of about 3 minutes to about 30 minutes.

26

27 48. The medium of claim 47 having a Cobb absorption slope of greater than 0.5
28 g/m²/min within in a test range of about 3 minutes to about 30 minutes.

29

30 49. The medium of claim 43 having a Cobb absorption slope of about 0.8
31 g/m²/min within in a test range of about 3 minutes to about 30 minutes.

32

- 1 50. The medium of claim 43 having a Cobb absorption slope of between about
- 2 $0.05 \text{ g/m}^2/\text{min}$ and about $1.0 \text{ g/m}^2/\text{min}$ within in a test range of about 3 minutes to
- 3 about 30 minutes.

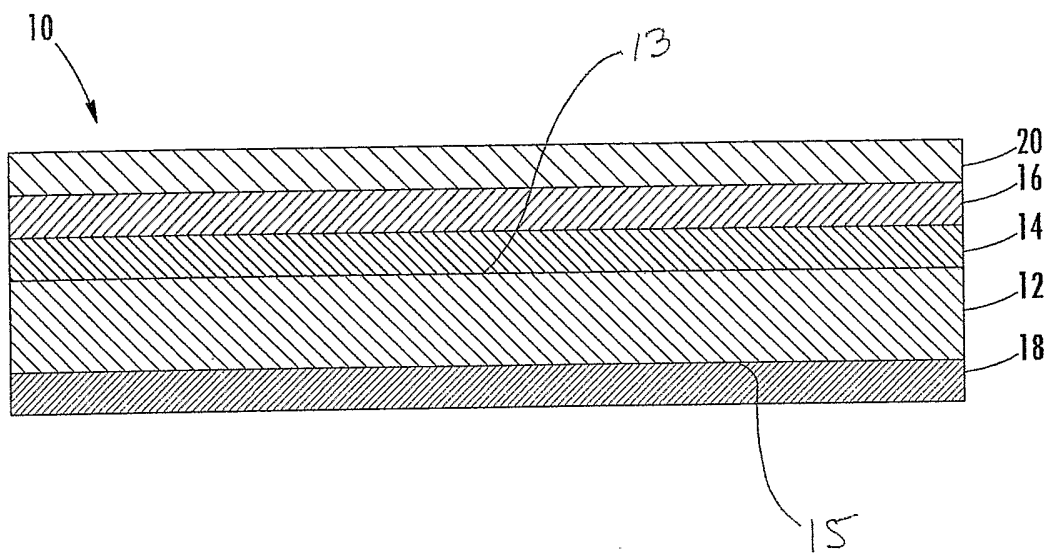

FIG. 1

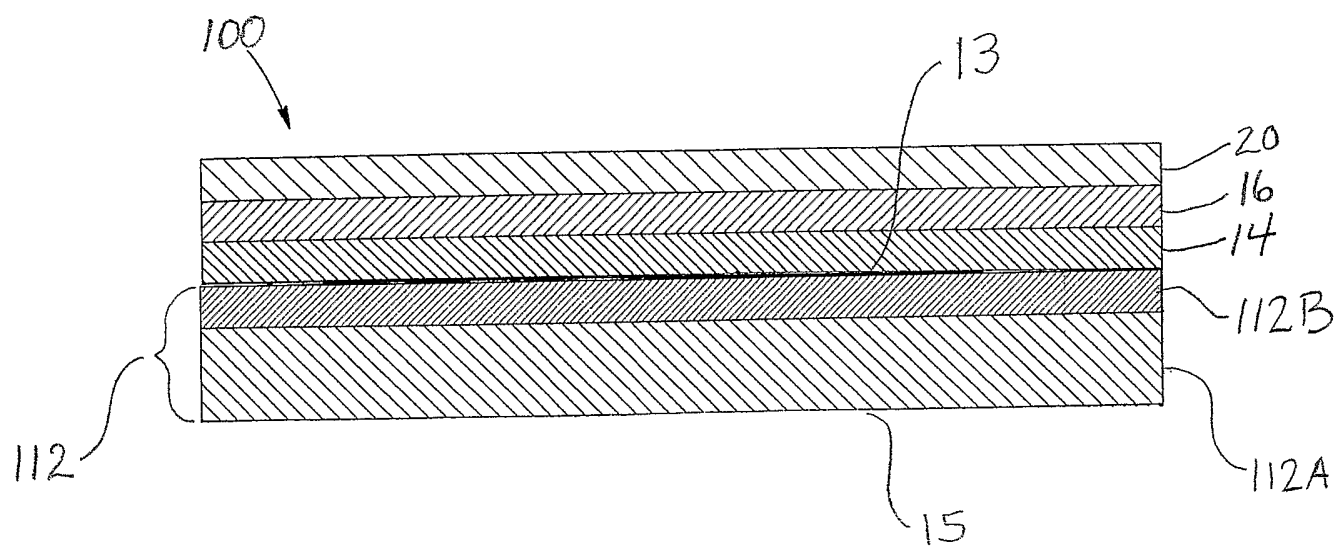

FIG. 2

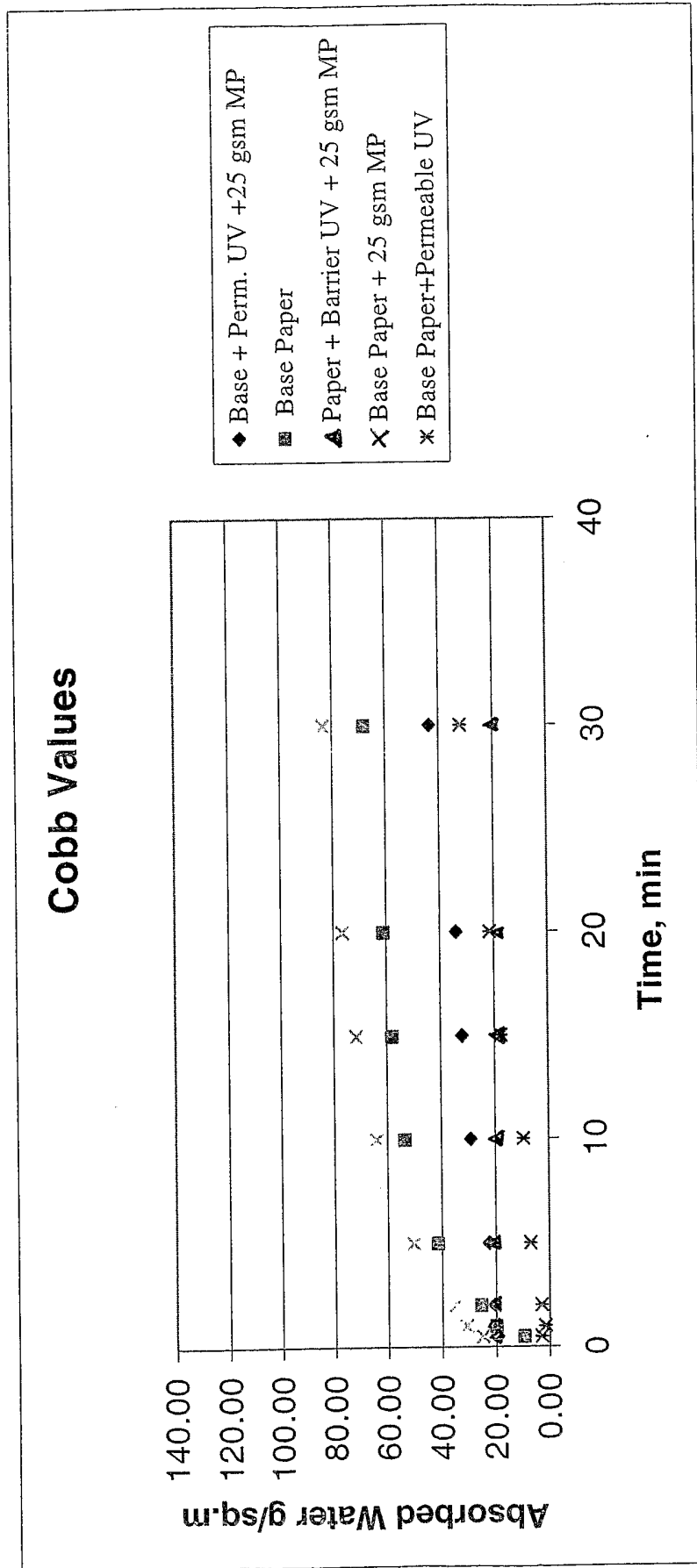

FIG. 3A

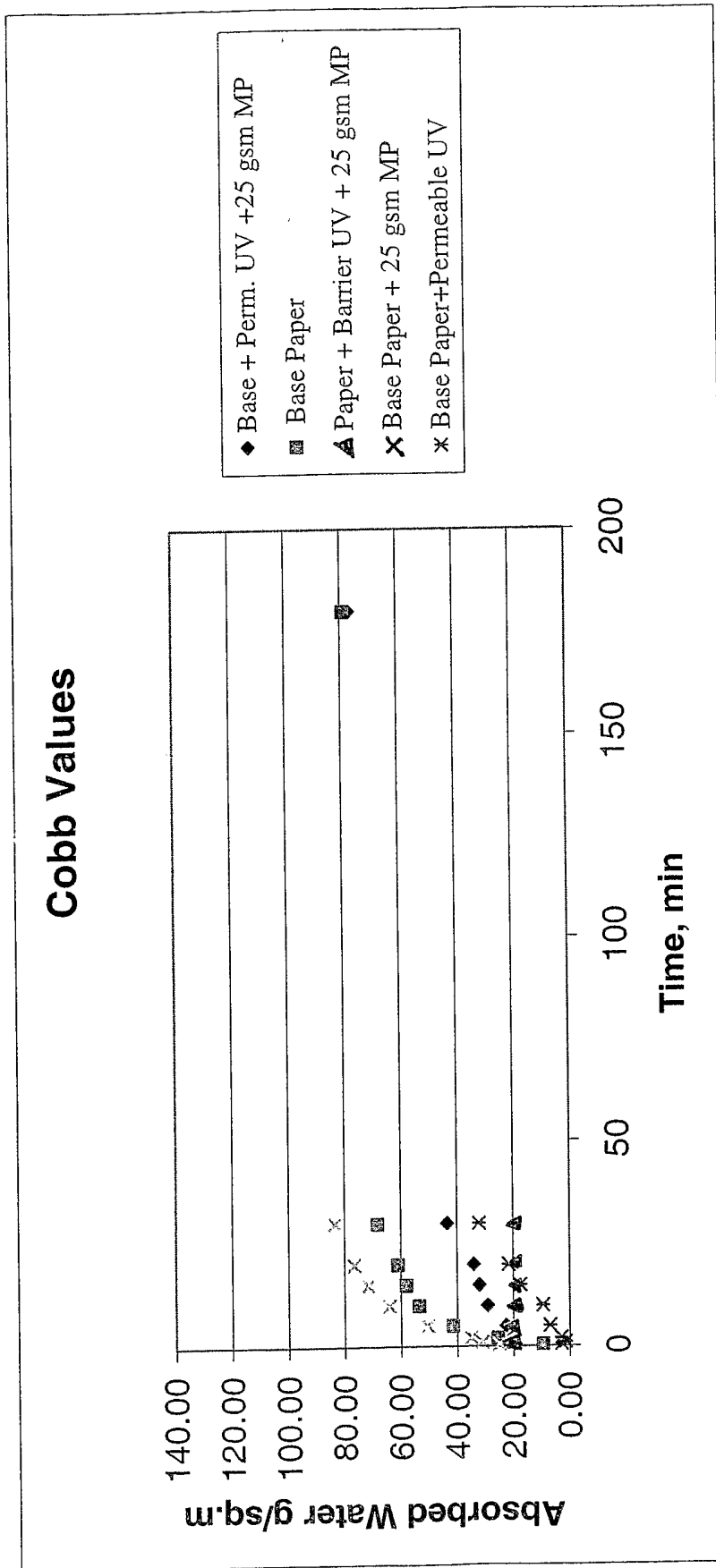

FIG. 3B

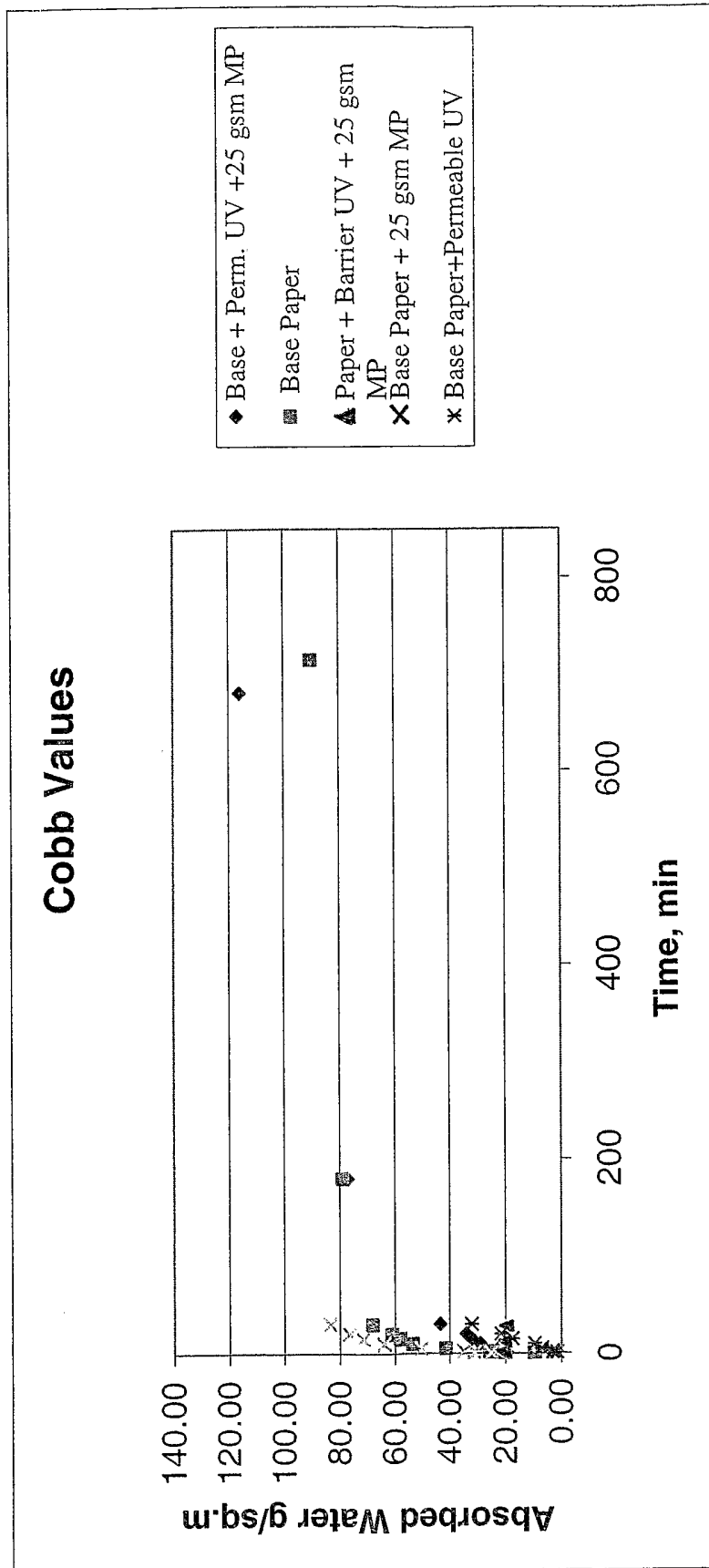

FIG. 3C.

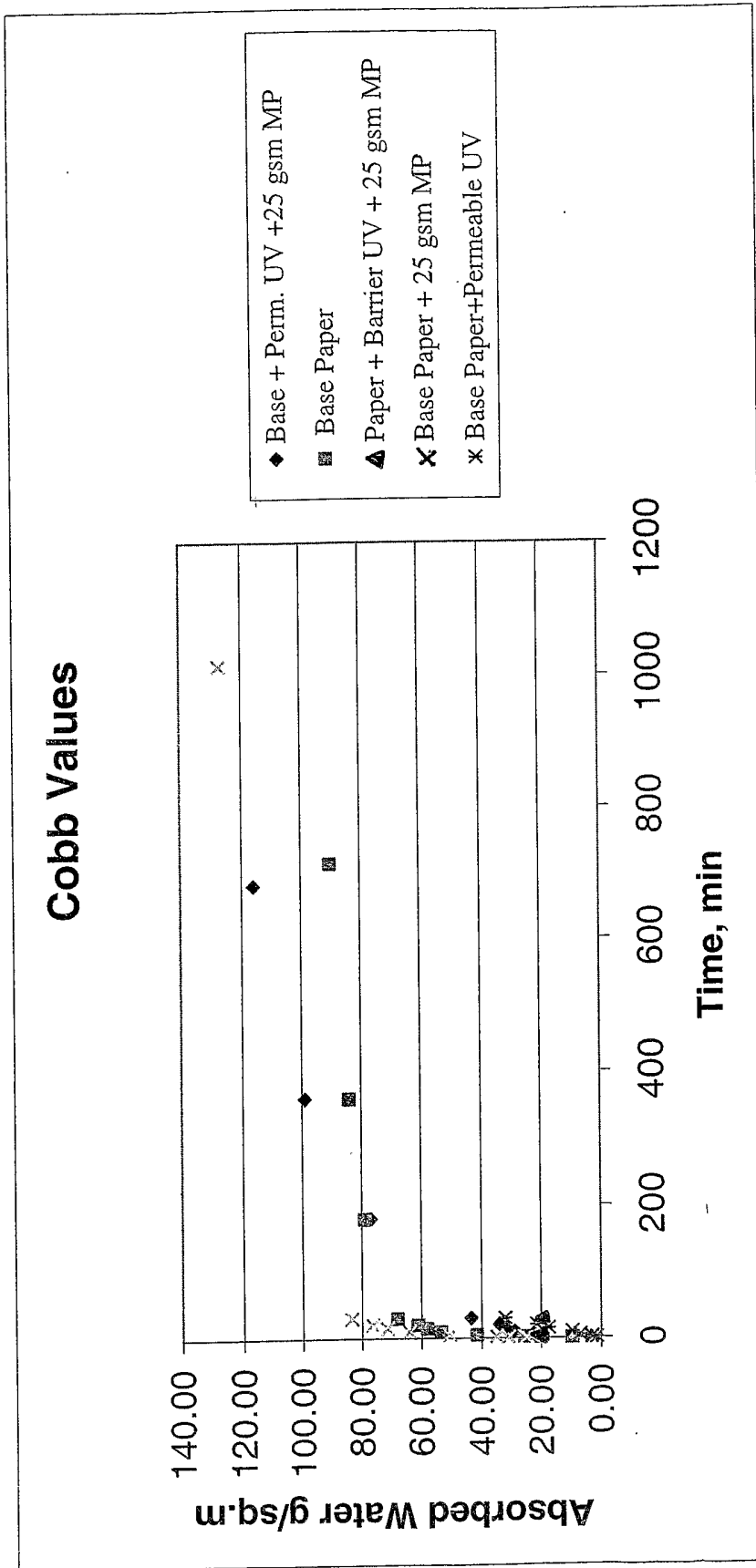

FIG. 3D