

(No Model.)

E. M. BENTLEY.

SWITCH ON OVERHEAD LINES IN ELECTRIC RAILWAYS.
No. 385,903. Patented July 10, 1888.

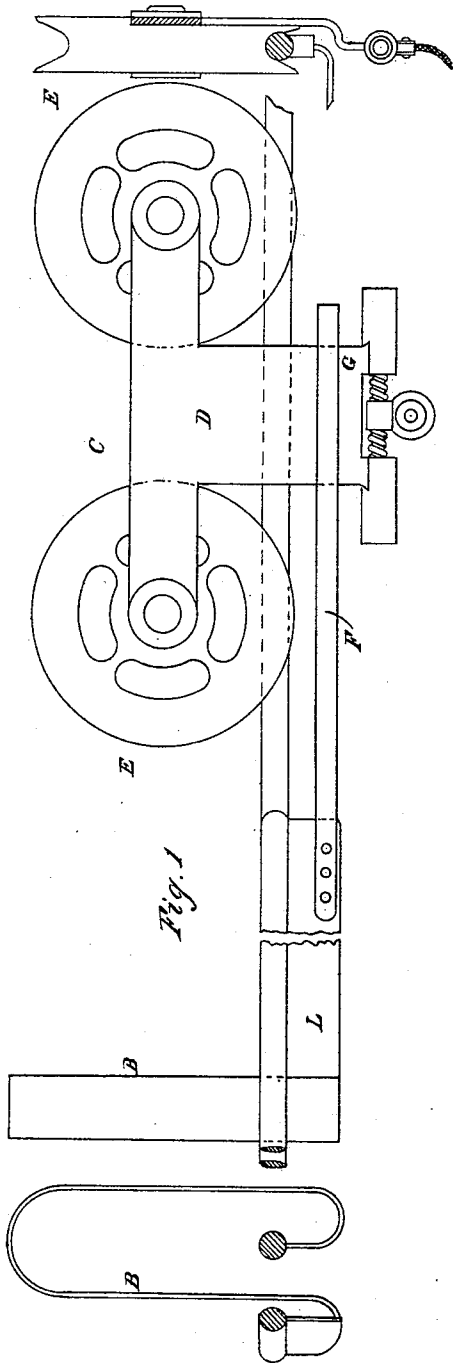

Fig. 1

Fig. 2

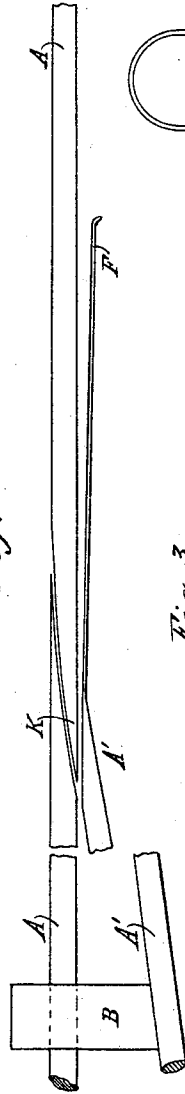

Fig. 3

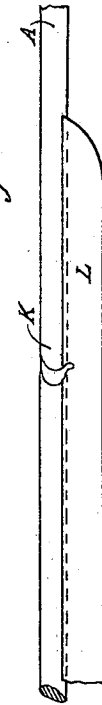
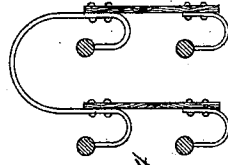

Fig. 4



WITNESSES

F. Periault
E. S. McKinney

INVENTOR,

Edward M. Bentley
by Bentley & Knight
attys.

UNITED STATES PATENT OFFICE.

EDWARD M. BENTLEY, OF NEW YORK, N. Y.

SWITCH ON OVERHEAD LINES IN ELECTRIC RAILWAYS.

SPECIFICATION forming part of Letters Patent No. 385,903, dated July 10, 1938.

Application filed January 20, 1888. Serial No. 261,358. (No model.)

To all whom it may concern:

Be it known that I, EDWARD M. BENTLEY, a citizen of the United States, residing at New York, in the county of New York, State of New York, have invented certain new and useful Improvements in Switches on Overhead Lines in Electric Railways, of which the following is a specification.

My invention relates to electric railways in which the main conductor is suspended above the railway, and a connection with a traveling vehicle maintained by means of a contact device adapted to ride upon the conductor, and a flexible conductor extending therefrom to the vehicle.

My invention consists in devices whereby the contact device is enabled to automatically take any desired course at a switch or branching point along the conductor.

In the accompanying drawings, Figure 1 is a side elevation of a contact device and a main-line conductor at a branching point. Fig. 2 is a plan of the same. Figs. 3 and 4 are details.

In the drawings, A represents a supply-conductor for an electric railway, suspended in any suitable manner above the railway.

A' is a branch conductor.

B is a brace or bracket holding the main and branch conductors in a definite relative position.

C is a contact device, consisting of a trolley having the wheels E journaled in a frame, D, which has a projection, G, extending down beside the wire on which the trolley runs to a point below it. A flexible conductor, which also serves as a pulley or towing device for the trolley, is attached to this downward projection on D. The conductors A and A' are held in such a relative position by the brace B that a sufficient space is left between the end of A' and the side of A for the passage of projection G as the trolley moves along the main line A. At the point where A and A' meet a frog, K, is formed on A, of a shape which would correspond with the prolongation of A', so that the contact device can pass from A' on to A without danger of derailment.

It will be seen that the wire A is substantially straight, so that a trolley approaching the branch would tend naturally to continue

its course along A. To make sure, however, that this always takes place, I attach a spring-guide, F, to the fin or spline L, which supports the end of A'. This guide F is beneath the line of the conductors, so that it will engage with projection G without interfering with wheels E. When a trolley is passing in the opposite direction from A' on to A, the guide F, being flexible, will yield to projection G and not interfere with the action of the trolley.

Fig. 3 is a side elevation of the frog K on conductor A.

Fig. 4 is an elevation of the brace B when two conductors are used, one above the other.

I claim—

1. In an electric railway, the combination, with a main conductor, of a branch conductor held in a definite position relative thereto, a contact device adapted to ride on either main or branch conductor, a projection from said contact device extending downward beside the conductor, a flexible guide for directing the contact device at the branch, the two conductors being held in such a relative position as to allow the passage of the said projections between them, and the main conductor having a frog at the meeting-point shaped to form a prolongation of the branch conductor, so as to permit the passage of the contact device from the branch to the main.

2. In an electric railway, the combination, with main and branch conductors, of a contact device connected to an electrically-propelled vehicle, the main and branch conductors being situated with an intervening space permitting the passage of the propelling device between them, a stationary flexible guide, and a projection from said contact device adapted to engage with said guide and thereby direct the contact device.

3. In an electric railway, the combination, with main and branch conductors, of a contact device having a propelling extension adapted to pass between main and branch conductors, and a stationary flexible guide for directing the contact device.

4. In an electric railway, the combination, with main and branch conductors, of a contact device adapted to both conductors and provided with a propelling extension, and a stationary

flexible guide having its free end extending along the main conductor away from the point of junction and adapted to engage with a projection on the contact device for directing the
5 same.

10 5. In an electric railway, the combination, with a main conductor, A, of a branch conductor, A', flexible guide F, a bracket, B, holding the two conductors in a fixed relative position, with an intervening space at the meeting point, and a contact device adapted to pass through the bracket B, and provided with an extension adapted to pass through the said space between the conductors.

6. In an electric railway, the combination 15 of a main conductor, A, and a branch conductor, A', the latter having guide F and the former having a frog at the branching point, forming, substantially, an extension of the branch conductor, with a contact device hav- 20 ing a grooved wheel to which the said frog is adapted.

EDWARD M. BENTLEY.

Witnesses:

G. RENAULT,
ROBT. W. BLACKWELL.