

(No Model.)

W. D. VAN DUZEE.
AUTOMATIC SEWER FLUSHING DEVICE.

No. 426,481.

Patented Apr. 29, 1890.

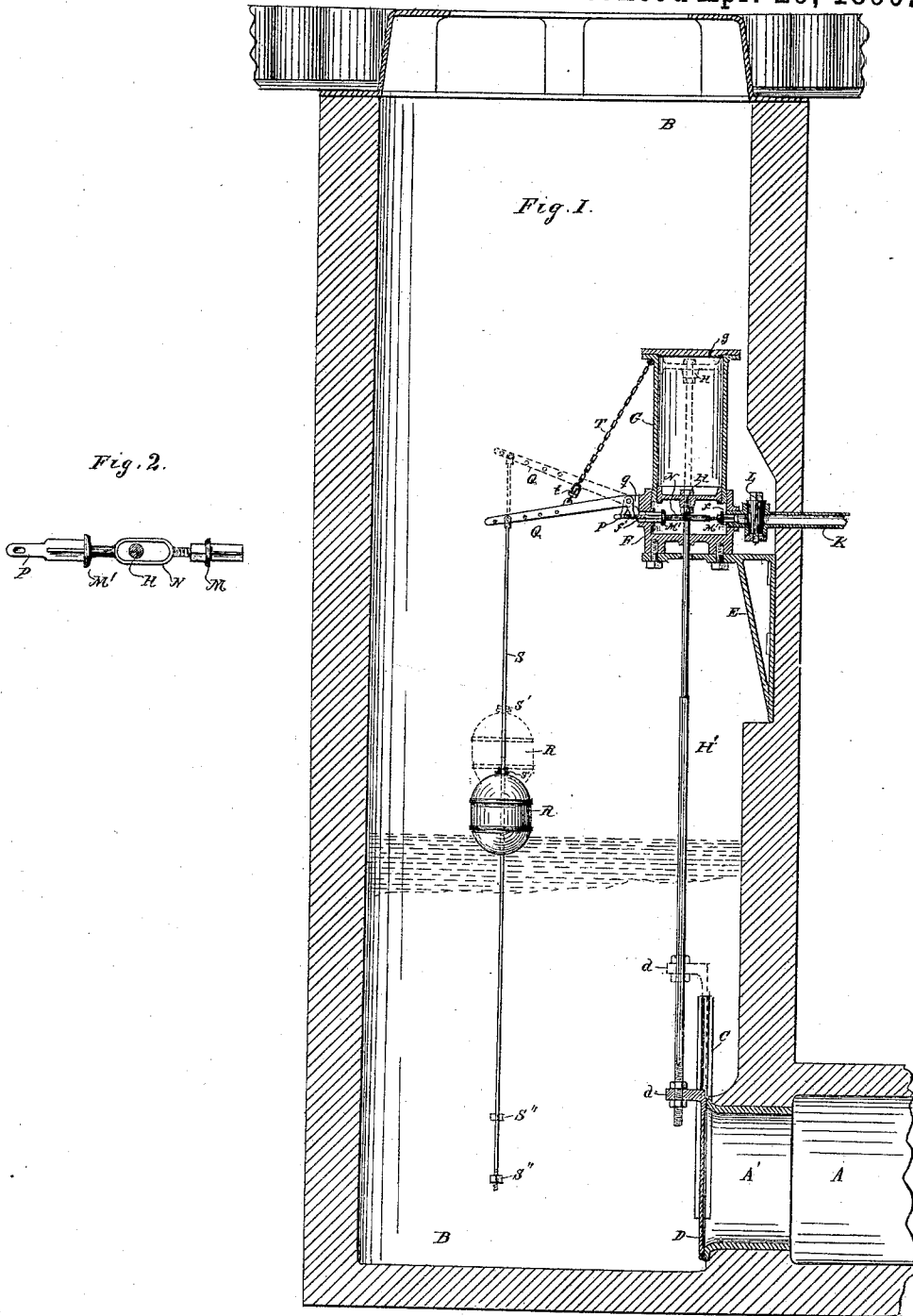

Witnesses
A. H. Opsahl,
Emma F. Olinore

Inventor
William D. Van Duzee
By his Attorney,
Jas. F. Williamson

UNITED STATES PATENT OFFICE.

WILLIAM D. VAN DUZEE, OF MINNEAPOLIS, MINNESOTA.

AUTOMATIC SEWER-FLUSHING DEVICE.

SPECIFICATION forming part of Letters Patent No. 426,481, dated April 29, 1890.

Application filed March 16, 1889. Serial No. 303,562. (No model.)

To all whom it may concern:

Be it known that I, WILLIAM D. VAN DUZEE, a citizen of the United States, and a resident of the city of Minneapolis, county of Hennepin, State of Minnesota, have invented a certain new and useful Automatic Sewer-Flushing Device, of which the following is a specification, reference being had to the accompanying drawings.

My invention relates to sewers, and has for its object to provide a simple, efficient, and reliable device for flushing the same. To this end I provide a gate for opening and closing the outlet from the man-hole extension of a sewer to the sewer-pipe and operate the same by a water-motor, which is preferably located within the man-hole at some point above the bottom thereof. The motor is provided with connections to a water-supply pipe leading to a head of water—such, for example, as a city water-main. The supply-pipe has a discharge into the man-hole above its bottom. Valve mechanism is arranged to control this discharge and the supply to the motor.

The valve mechanism is operated from a float in the man-hole, rendering the action of the apparatus automatic. The discharge from the supply-pipe is preferably made through the motor itself, the motor being provided with inlet and outlet openings for the purpose. A valve is located in the outlet-opening, which is operated by the float in the man-hole to close the same at a certain stage of water, whereupon the pressure becomes effective to operate the motor. A valve may also be placed in the inlet to the motor and both valves be operated from a single float.

In the drawings I have shown my preferred construction. Therein, like letters referring to like parts throughout, Figure 1 is a vertical transverse section of my invention in working position. Fig. 2 is a plan of the water-chest valves detached.

A represents the head end of a sewer. B is the man-hole connected thereto by the thimble A'.

C are vertical gate-guides supported in any suitable way on the opposite sides of the thimble A' within the man-hole B. D is a vertically-movable gate mounted in said guides and provided with a projecting lug *d*.

E is a bracket-shelf secured to the walls of the man-hole at some point above its bottom.

F is an annular water-chest, open at its upper end, rigidly secured to the shelf E. 55

G is a water-cylinder open at its lower end and connecting with the open end of the water-chest F by a tight joint.

H is the piston, mounted in the cylinder G and provided with a rigid stem H', passing 60 through the chest F and adjustably secured at its lower end to the lug *d* on the gate D. The water-chest F is provided with inlet and outlet openings *f* and *f'* in its walls, preferably directly opposite to each other. 65

K is a lateral pipe from the opening *f* for connection with the water-main.

L is a stop-cock in the pipe K.

M M' are valves located in the openings *f* and *f'*, respectively. N is a common stem 70 connecting the same. The valve M is adjustably mounted on its stem by a screw-thread or otherwise.

P is a projection from the stem N or valve M, extending out through the opening *f'*. 75

Q is a bell-crank lever pivoted to a projecting lug *q* on the water-chest F and having its short arm in engagement with a slot or lug on the stem P.

R is a float movable on the rod S, which is 80 connected at its upper end to the long arm of the bell-crank lever Q.

S' is an adjustable collar on the rod S above the float R.

S'' is a similar adjustable stop on the rod 85 S below the float R and near the lower end of the rod.

The cylinder G should be provided with an air-vent *g*.

The operation is as follows: In the normal 90 position of the parts communication with the water-main is cut off by the stop-cock L and the gate is in its lowermost position, closing the outlet from the man-hole, and the valves M and M' are in such positions with reference 95 to their seats as not to close the inlet and outlet from the water-chest. If the stop-cock L be turned so as to connect the water-chest F with the water-main, the water will freely flow through the chest and into the man-hole 100 B, gradually filling the same, carrying the float on the surface until it strikes the collar

S'. Then as additional water flows in the rod S and the lever Q will be raised, drawing outward the stem P and the valve M', closing the outlets f' from the water-chest and more widely opening the inlet-opening f . The water-pressure will then become effective on the piston H, moving the same upward in the cylinder G and carrying with it the piston-rod H' and the gate D, allowing the water to fall into the sewer and flush the same. As the water flows from the man-hole the float R slides down the rod until it strikes the lower stop S''. Then on its further movement it will draw down with it the lever Q, opening the outlet f' and partially closing the inlet f of the water-chest F. The piston H being thus relieved from the water-pressure, the gate D will fall by its own weight, closing the outlet from the man-hole. The water will again flow into the man-hole through f and f' and the flushing be continued intermittently in this manner until the stop-cock L is turned to cut off the supply from the water-main.

T is a chain or other flexible connection provided with a swiveled take-up device t , and is connected at one end to the cylinder G or some other fixed support above the lever Q and at its other end to the long arm of said lever for limiting the downward movement of the lever Q and the closing movement of the valve M.

It should be noted that instead of the supply-pipe having its discharge to the man-hole through the motor the supply-pipe might have two branches—one to the motor and the other to the man-hole—with a valve at their point of union, and the float be made to operate this valve. In that event the valve would be normally opened to the discharge branch and would close the discharge and open the branch to the motor when moved by the float into another position.

It is evident that instead of the outlet from the man-hole being in the vertical plane, as shown, a curved thimble might be used, with its open end terminating in the horizontal plane, and that either a horizontally-movable gate or a hinged lid might be used to close the same, and be operated on the same principle by connections from the piston H. The valve M is made adjustable on its stem in order that it may be set in the proper relative position to the valve M' to vary the inlet and outlet openings, as required. By setting these valves in a proper relative position the inlet-opening at f is comparatively small when f' is wide open and the water is flowing freely through the chest. When the valve M' is drawn outward against its seat, closing the outlet f' , the inlet f is opened wide, permitting the water to flow freely and quickly into the chest and cylinder, causing a quick movement of the piston and the gate.

The invention was designed for flushing the sewer from the city water-main or other head

of water operating the motor, and the valves M and M' are made adjustable on a common stem simply to vary the inlet-openings of the water-chest with reference to each other as required for a quick movement of the gate. It is evident, however, that if the opening of the stop-cock L be in line with the supply-pipe and the valve M so set as to close the inlet f when the float is in its lowermost position the valves will be operated from accumulated surface water in the man-hole. It might be of service in some places to apply the construction in this manner.

What I claim, and desire to secure by Letters Patent of the United States, is as follows:

1. The combination, with a sewer-pipe, of a receptacle—such as a man-hole extension—at the head of the same, a gate for opening and closing the sewer-pipe, a water-pressure motor for operating said gate, having a water-chest in connection with a head of water, a valve in said water-chest, and a float for controlling the valve, substantially as and for the purpose specified.

2. The combination, with a sewer-pipe, of a receptacle—such as a man-hole extension—at the head of the same, a gate for opening and closing said pipe, a water-pressure motor for operating said gate, having a water-chest provided with an inlet from a head of water and an outlet to said receptacle, valves in said chest for governing the inlet and outlet openings, and a float in said receptacle connected to said valves, adapted to operate the same to enlarge the inlet and close the outlet of the motor and reversely starting and stopping the motor, substantially as described, whereby the gate is moved to open or close the sewer-pipe, according to the presence or absence of a certain level of water in said receptacle.

3. The combination, with a sewer-pipe, of a receptacle—such as a man-hole extension—at the head of the same, a gate for opening and closing said pipe, a water-chest above the bottom of the receptacle, having an inlet from a head of water and an outlet to said receptacle, a vertical cylinder secured to upper end of said chest and in communication therewith, a piston in said cylinder provided with a stem projecting through the bottom of the water-chest and connected to said gate, a valve in said water-chest outlet, and a float in said receptacle connected to said valve for operating the same, substantially as described.

4. The combination, with a sewer-pipe, of a receptacle—such as a man-hole extension—at the head of the same, a gate for opening and closing said pipe, a water-chest above the bottom of said receptacle, having an inlet-pipe from a head of water and an outlet to said receptacle, a vertical cylinder secured to the top of said chest and in communication therewith, a piston in said cylinder provided with a stem projecting through the bottom of the chest and connected to the said gate, valves in the inlet and outlet openings of said chest,

and a float in said receptacle connected to said valves for operating the same, substantially as described.

5 5. The combination, with a sewer-pipe, of a receptacle—such as a man-hole extension—at the head of the same, a gate for opening and closing said pipe, a water-pressure motor for operating said gate, having a water-chest in connection with a head of water and an outlet to said receptacle, a valve in said outlet, a lever having a connection to said valve, a pendent rod attached to said lever and extending approximately to the bottom of said receptacle and provided with float-stops, and a float loosely mounted on said rod and freely movable between said stops with the stage of the water and operating said rod and valves when bearing against said stops, substantially as described.

20 6. The combination, with a sewer-pipe, of a receptacle—such as a man-hole extension—at the head of the same, a gate for opening and closing said pipe, a supply-pipe from a head of water having a discharge into said receptacle above the bottom thereof, a water-pressure motor for operating said gate, having a water-chest in connection with said supply-pipe, a valve for opening and closing the discharge from the supply-pipe, and a float in said

receptacle connected to said valve for controlling the same by the stage of water therein, substantially as described. 30

7. The combination, with a sewer-pipe and its man-hole extension, of a gate for opening and closing the sewer-pipe, a water-chest in said man-hole above the bottom thereof, having inlet and outlet openings, valves in said openings mounted on a common stem, a vertical cylinder secured to said chest a piston in said cylinder provided with a stem projecting through the bottom of said chest and connected to said gate, a lever having a connection to said common valve-stem, a pendent rod secured to said lever provided with float-stops adjustably mounted thereon, and a float loosely mounted on said rod between said stops, substantially as described. 35 40 45

8. In the apparatus described, the combination, with the valve-operating lever and the float, of a chain or other flexible connection attached at one end to the lever and at the other to some fixed support above the lever for limiting the downward movement of said lever, substantially as described. 50

WILLIAM D. VAN DUZEE.

In presence of—

JAS. F. WILLIAMSON,
EMMA F. ELMORE.