

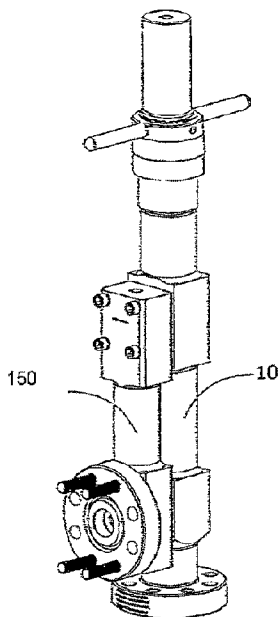

(22) Date de dépôt/Filing Date: 2019/01/29  
(41) Mise à la disp. pub./Open to Public Insp.: 2019/07/29  
(45) Date de délivrance/Issue Date: 2022/10/04  
(30) Priorité/Priority: 2018/01/29 (US62/623,390)

(51) Cl.Int./Int.Cl. *E21B 33/03* (2006.01),  
*E21B 33/08* (2006.01), *F04B 53/18* (2006.01)  
(72) Inventeurs/Inventors:  
MURDOCH, SCOTT, CA;  
WATCHARIN, SUTTIPISETCHART, CA;  
VETTER, STEPHEN, CA;  
DURLING, LEIGH, CA  
(73) Propriétaire/Owner:  
TIER 1 ENERGY TECH, INC., CA  
(74) Agent: BENNETT JONES LLP

(54) Titre : SYSTEME DE LUBRIFICATEUR ET DISPOSITIF DE TETE COMPACT  
(54) Title: COMPACT LUBRICATOR AND HEADER SYSTEM



(57) **Abrégé/Abstract:**

A plunger lift lubricator assembly includes a lubricator and a header. The lubricator has a lubricator body defining a longitudinal inner bore, and an upper lubricator assembly comprising an anvil, spring cap, and a spring. The header is disposed immediately adjacent and parallel to the lubricator body, defines a longitudinal bore in fluid communication with the lubricator inner bore, and defines a header exit port with attachment means to external fluid handling equipment. The lubricator assembly has a horizontal dimension from the lubricator inner bore centre line to header exit port attachment means, which is the same as a horizontal dimension of a flow-tee of a wellhead. The lubricator can be installed in the wellhead by removing the flow- tee and replacing it with the lubricator assembly, without further modifying the wellhead to fit the lubricator assembly, and connecting the header exit port to the external fluid handling equipment.

## ABSTRACT

A plunger lift lubricator assembly includes a lubricator and a header. The lubricator has a lubricator body defining a longitudinal inner bore, and an upper lubricator assembly comprising an anvil, spring cap, and a spring. The header is disposed immediately adjacent and parallel to the lubricator body, defines a longitudinal bore in fluid communication with the lubricator inner bore, and defines a header exit port with attachment means to external fluid handling equipment. The lubricator assembly has a horizontal dimension from the lubricator inner bore centre line to header exit port attachment means, which is the same as a horizontal dimension of a flow-tee of a wellhead. The lubricator can be installed in the wellhead by removing the flow-tee and replacing it with the lubricator assembly, without further modifying the wellhead to fit the lubricator assembly, and connecting the header exit port to the external fluid handling equipment.

## COMPACT LUBRICATOR AND HEADER SYSTEM

### FIELD OF THE INVENTION

A header with associated lubricator controls fluid handling at the wellhead of an oil and gas well where a plunger/lubricator lift system is deployed, and provides a novel compact lubricator with header which can replace a conventional wellhead flow-tee without modifying or moving other wellhead equipment to accommodate the new lubricator and header replacing the old flow-tee. The header with associated lubricator encloses a conduit with seals in the interfaces between the header and lubricator or between the header and exit attachment means, where the conduit may provide a means of flow restriction through machined geometry or by retaining a reduced diameter component through various means of attachment.

### BACKGROUND OF THE INVENTION

Producing oil and gas wells sometimes produce water as well as hydrocarbons from formation. When sufficient, gas flow from formation will remove fluids from the well naturally. But as the formation pressure declines and the gas to liquid ratio decreases, liquid (generally water) will begin to accumulate in the well. When a produced water column in the wellbore reaches a sufficient height, the resulting hydrostatic pressure will exert pressure on the formation which exceeds the formation's pressure preventing gas or produced hydrocarbon flow from the formation up to surface. To overcome this, the water may be removed from the well using one of a number of artificial lift systems. One such system is plunger lift system whereby a plunger deployed in the wellbore drops into the accumulated water column at the bottom of the well where it forms a piston within the cylinder formed of the wellbore's inner walls (typically casing or tubing) which is a movable seal between the formation's production pressure below the piston and the water column above the piston. Gas produced below the plunger forces it and water above it toward the surface, where the water can be removed and the pressure on the formation from the water column can be reduced. This function is performed cyclically, typically without intervention by the operator, and the fluid above the piston is ejected through

a lubricator installed on the top of the wellbore, through the lubricator's exit ports to fluid handling equipment at surface.

## SUMMARY OF THE INVENTION

5 A lubricator with compact dimensions is provided by reducing the complexity of conduits from upper and lower lubricator fluid exit ports by adding the header of this invention, which may be fixed directly to the upper and lower exit ports of the lubricator and disposed closely adjacent to the lubricator's body [Fig.1 and Fig.2]. The attachment between the lubricator's exit ports and the header's inlet ports may include a seal subassembly ("seal sub"). Where the header's inlet ports attach to the lubricator's exit ports, flow restrictor means may be installed  
10 differentially tailor flow rates from the upper and lower ports. The header gathers fluid flow from the upper and lower exit ports of the lubricator providing a conduit to the header's exit port, which is provided with attachment and sealing means for external fluid-handling systems.

The header or lubricator may be provided with servicing access via a removable sealed cover  
15 over an access port in the wall of the header or lubricator opposite the seal sub, through which changes to flow restrictor means installed between the lubricator and header may be effected [Fig.4 and Fig.5]. The flow restrictor means may be adjustable valve means, which may be manipulated from outside the lubricator and header body, preferably by a handle outside the bodies which may be operably attached via a sealed shaft to a valve in the sub seal or between  
20 a lubricator exit port and the header, or may be static flow restrictor orifice plates or similar.

By removing complexity and equipment (valves, short piping conduits at each exit port), and disposing the header directly adjacent to the lubricator, the compact lubricator system can have similar dimensions to a conventional flow-tee which the lubricator and header are designed to  
25 replace, for attachment to external gathering equipment without significant (or any) modification of wellhead fittings and equipment. For example, a horizontal distance from the lubricator's bore's center-line to the header's exit port attachment flange may be equivalent to the horizontal distance between a typical slow-tee's conduit's center-line and the flow-tee's flange attachment for external gathering equipment. Similarly, a vertical distance from the

bottom face of the bottom flange to the horizontal center-line of the side outlet of the lubricator may be substantially the same as the distance between equivalent points and a conventional flow-tee.

5 The header may be fabricated by making a lengthwise bore through a solid part, sealing the bore's end, and intercepting the bore with three perpendicular (to the bore) similarly bored ports: one to mate with a lubricator's upper exit port, a second to mate with the lubricator's lower exit port, and a third, opposite to the first two to provide an exit port from the header. Appropriate fittings or seal subs are added to each port to mate with the lubricator and with external fluid handling equipment. Those fittings may also include flow restrictor means (such as plate with orifice).

10

The header in another embodiment may have an intermediate crossblock is installed at the base of the lubricator, and the crossblock provides a fluid conduit in the operable communication with the header, wherein an upper port of the header connects directly to the lubricator's upper exit port, and the open bottom of the header connects to the crossblock; the crossblock provides an exit port to the header from the lubricator, and provides communication from the header's exit; port, through the header and to a flange connection on the crossblock to external fluid handling equipment.

15

#### BRIEF DESCRIPTION OF THE DRAWINGS

Figure 1 is a group of figures showing an embodiment of the header and lubricator.

20 Figure 1a is a side elevation of the header and lubricator toward the header exit port.

Figure 1b is a cutaway or cross-section of the lubricator and header of Figure 1a along line 1b-1b.

Figure 1c is a cross-section of the lubricator along the line 1c-1c of figure 1d.

Figure 1d is a top elevation of the lubricator and header.

25 Figure 1e is a section view of seals at point 1e of Figure 1b.

Figure 1f is a cross-section view of the header at line 1f-1f in Figure 1b.

Figure 1g is a cross-section view of the header at line 1g-1g in Figure 1b.

Figure 1h is a cross-section view of the header at line 1h-1h in Figure 1b.

5 Figure 1j is a cross-section view of the catcher assembly of the lubricator at area 1j of Figure 1c.

Figure 1k is a cross-section of a seal subassembly from area 1k of Figure 1b.

Figure 2 is a perspective drawing of an oblique elevation of a lubricator and header from the header side of the assembly.

Figure 3 is a set of drawings of a lubricator and header assembly of the PRIOR ART.

10 Figure 4 is a set of drawings of a lubricator and header assembly of the invention with access plate.

Figure 4a is a side elevation of the header and lubricator toward the header exit port.

Figure 4b is a cutaway or cross-section of the lubricator and header of Figure 4a along line 4b-4b.

15 Figure 4c is a cross-section of the lubricator along the line 4c-4c of figure 4d.

Figure 4d is a top elevation of the lubricator and header.

Figure 4e is a section view of seals at point 4e of Figure 4b.

Figure 4f is a cross-section view of the header at line 4f-4f in Figure 4b.

Figure 4g is a cross-section view of the header at line 4g-4g in Figure 4b.

20 Figure 4h is a cross-section view of the header at line 4h-4h in Figure 4b.

Figure 4i is a cross-section view of the access plate at area 4i of Figure 4b.

Figure 4j is a cross-section view of the catcher assembly of the lubricator at area 4j of Figure 4c.

Figure 4k is a cross-section of a seal subassembly from area 4k of Figure 4b.

5 Figure 5 is a perspective drawing from a side of the header and lubricator assembly of the invention showing an access plate and the exit port of the header.

Figure 6 is 4 sub-figures of an externally controllable valve included in a seal sub of the invention, 6a showing the valve body closed from an oblique angle, 6b showing it open from the same angle, 6c showing the valve closed from a direct perspective into the seal sub, and 6d showing a cross-section at line 6d-6d of figure 6c.

10 Figure 7 is a group of 4 sub-figures of a seal sub with orifice plate held against a détente in the seal sub (a spring clip in a groove) by a spring clip in another groove in the inner surface of the seal sub's bore: 7a from an oblique angle, 7b from a side of the seal sub, 7c directly into the bore of a seal sub, and 7d a cutaway at line 7d-7d of figure 7c.

15 Figure 8 shows a threaded insert (8b) for threaded engagement with mating threads in the interior bore of a seal sub (8a and 8d), the threaded insert having a flow-restricted internal bore of smaller diameter than the seal sub. 8c is an end-view of the seal sub with insert mounted.

Figure 9 shows several portrayals of a lubricator of this invention with a cross-block structure.

Figure 9a is a side elevation of the header and lubricator toward the header exit port.

20 Figure 9b is a cutaway or cross-section of the lubricator and header of Figure 9a along line 9b-9b.

Figure 9c is a cross-section of the lubricator along the line 9c-9c of figure 9d.

Figure 9d is a top elevation of the lubricator and header.

Figure 9e is a section view of seals at point 9e of Figure 9b.

Figure 9f is a section view of the lubricator along the line 9f-9f of Figure 9b.

Figure 9g is a section view of the upper face of the crossblock and the lubricator along the line 9g-9g of Figure 9b.

Figure 9h is a section view of a threaded flow resistor at point 9h of Figure 9b.

5 Figure 9i is a magnified section view of the catcher assembly at box 9i of Figure 9c.

Figure 10 shows an oblique elevation/perspective drawing of a compact lubricator with cross block.

#### DETAILED DESCRIPTION

10 The invention is of a header 150 for a lubricator 10, or the assembly of lubricator and header, the header 150 being in sealed attachment directly and without intermediary extension parts to upper and lower exit ports of the lubricator 10, the header 150 disposed closely adjacent to the lubricator's 10 body, the header 150 providing fluid communication between the lubricator's inner bore 20 through the lubricator's exit ports into internal passageways 40 within the header 150 at the sealed attachments with the exit ports, and through the header's internal passageways  
15 through the header's body to an exit port of the header. The header 150 is provided with attachment means to provide fluid communication from the exit port of the lubricator 10 through to the header 150 to external fluid handling equipment. The attachment means may include a seal sub. The lubricator 10 includes an upper lubricator assembly including an anvil 22, removable spring cap 24, and spring 26.

20 The header 150 may be provided with flow restriction means installed between at least one of the lubricator's exit ports and the header 150 to tailor relative flow rates from the upper and lower exit ports of the lubricator 10.

The attachment between the lubricator's exit ports and the header's inlet ports may include a seal subassembly ("seal sub") 50. The seal sub may take several forms, and examples are  
25 included in figures 1 and 1k, 4 and 4k, 6, 7 and 8.

Where the header's inlet ports attach to the lubricator's exit ports 30, flow restrictor means may be installed, preferably within a seal sub 50, to differentially tailor flow rates from the upper and lower exit ports. The flow restrictor may be of any suitable arrangement, but preferably is an orifice plate 60 attached within the flow path of the interior passage of the sub seal 50.

5 Alternatively, the flow restrictor may be a short tubular-shaped insert 70 with threaded external surface 72, those external threads for mating with threads on the interior wall of a portion of the seal sub, and the insert's inner bore 74 being tailored to restrict fluid flow through the sub seal 50 when installed.

The header 150 or lubricator 10 may be provided with servicing access 160 via a removable  
10 sealed cover over an access port in the wall of the header 150 or lubricator 10 opposite a seal sub, through which changes to included flow restrictor means installed between the lubricator 10 and header 150 may be effected. The flow restrictor means may also be adjustable valve means 80 which may be manipulated from outside the lubricator 10 and header body, preferably by a handle 82 outside the bodies operably attached via a sealed shaft 84 to a valve 86 in the  
15 sub seal or between a lubricator exit port 30 and the header 150 [Fig.6].

The header 150 gathers fluid flow from the upper and lower exit ports 30 of the lubricator 10 providing a conduit to the header's exit port, which is provided with attachment and sealing means for external fluid-handling systems.

The flow restriction means in the flow path from a lubricator exit port through the attachment  
20 (seal sub) and header 150 may comprise a flow restriction plate with an orifice 60, the plate's orifice choking a fluid flow path from the lubricator 10 into the header 150, or any other suitable flow restriction mechanism.

The attachment means to the upper and lower exit ports of the lubricator 10 enclose a conduit with seals across the interface of the header 150 and lubricator 10, the seals may preferably be  
25 incorporated in the seal sub and the interfaces between the lubricator exit port, the seal sub and the header 150.

The assembly provided by the header 150 and lubricator 10 preferably has similar dimension in at least the aspect of the horizontal distance from the lubricator's and a comparative flow-

tee's vertical bore centre-line to the header's and the flow-tee's exit port attachment flange, in order to conveniently be installed in place of a conventional flow-tee on a well-head without rearranging nearby and adjacent wellhead equipment or attachments.

5 The lubricator header can be fabricated from a solid part with two ends by making a lengthwise bore through the part from end to end, sealing the bore's ends, and making perpendicular bores intercepting the lengthwise bore to provide internal passageways in the header 150, with two of the perpendicular bores from one direction on a side of the header 150 to be assembled to the lubricator and the bores spaced to mate with exit ports of the lubricator, and a third intercepting bore to provide an exit port from the header 150; the perpendicular bores being  
10 provided with attachment means where they exit the part (header) for attachment to the lubricator and to external fluid collection equipment, the attachment means preferably made to accommodate appropriate sealing means, for example a seal sub at the ports mating with the lubricator 10 and a gasket or similar seal for the attachment to external fluid handling means.

15 The header 150 may be made from any suitable substance, but preferably from a high strength metal such as a chrome-moly steel alloy or stainless steel alloy.

The attachment means at the lubricator exit port may be a threaded box, single or multi piece bolted clamp over flat or profiled surface with seal, or bolted clamping system enclosing a conduit with seals. The attachment means may also comprise interior features in a lubricator exit port and mating header port to capture and accommodate a seal sub or other sealing means,  
20 examples of which are shown in more particularity in figures 1 and 1k, 4 and 4k, 6, 7 and 8.

Examples of an included flow restrictor at or near at least one lubricator exit port may be a removable plate 88 with a restriction orifice that may be of differing diameters, the fixed internal diameter of a seal sub, or an internal surface of the seal sub attachment means to mate with and receive and hold a removable and replaceable flow restrictor. The flow restrictor may  
25 be an orifice plate, an insert with smaller internal diameter than the exit port or attachment means, a ball-valve or other conventional valve means, or any suitable flow restrictor; the attachment means for the flow restrictor to the seal sub attachment means or header 150 may

be a détente and spring-clip, mating threaded parts, or any suitable flow restrictor attachment mechanism.

The header 150 and lubricator 10 assembly will preferably have similar dimensions in at least the aspect of the horizontal distance from the header 150 with associated lubricator's and a comparative flow-tee's vertical bore centre-line to the header's and the flow-tee's exit port attachment flange, in order to conveniently be installed in place of a conventional flow-tee on a well-head without rearranging nearby and adjacent wellhead equipment or attachments.

The header and lubricator assembly may also preferably have similar dimensions in at least the aspect of the vertical distance from the header 150 with associated lubricator's lower exit port horizontal centerline and a comparative flow-tee's exit port horizontal centerline to the header 150 with associated lubricator's and flow-tee's base or well-head connection flange, in order to conveniently be installed in place of a conventional flow-tee on a well-head without rearranging nearby and adjacent wellhead equipment or attachments.

The header/lubricator assembly preferably will fit in the dimensional space of a pre-existing flow-tee in two directions (three dimensions) so as to be easy to install in place of the flow-tee to provide the functions of a lubricator in an artificial plunger lift system (i.e. plug and play). That is, during plunger operations, a plunger 5 rises in the lubricator's inner bore 20, and hits the anvil 22, which is cushioned by the spring 26. The removable spring cap 24 allows for assembly of and access to the internal elements.

By having a capability to tailor the respective flow rates of the lubricator's exit ports, the assembly of header with lubricator and flow restriction means can provide multiple flow paths (i.e. upper and lower ports) for plunger operations while staying within the allowed dimensional space of the pre-existing flow-tee.

The attachment between the header 150 and lubricator exit ports provide conduits with seals (or seal subs or interface conduits) to provide a fluid-tight seal between the interface of header/lubricator or header/flowline ports. Conduits with seals, and flow restrictor means or adjustable valves as described may provide a means of restricting flow at a particular desired port (or ports), and in at least some embodiments are replaceable to change the amount of restriction or replaceable when damaged through flow erosion or chemical/well fluid corrosion.

In an embodiment, service access may be provided through ports and sealed cover plates (or

similar) to change or service the flow restrictors without disassembling the header 150, sub seal or lubricator from one another.

Restricting flow can be done, for example, through 1) machining a portion of the header 150 conduit bore diameter to a specific size, 2) providing an attachment means such as in a seal sub  
5 50 to retain orifice plates of various hole diameters, 3) via an internal thread in the conduit meant to retain replaceable chokes (sub seal insert with reduced bore). An alternative might be an adjustable valve 86 in a seal sub, with an external handle 82.

As an additional capability, the lubricator 10 could have a lower exit port on the OPPOSITE side of the conventional lubricator geometry with suitable attachments and thereby allowing  
10 fluid flow from the casing in situations where production is via included tubulars within the casing (i.e. from a port in communication with the casing/tubing annulus of the wellbore) which could then be tied into fluid communication with the header 150 or the lubricator 10 as well. This could be done within or outside of the header 150 and could replace a flow-CROSS as opposed to the conventional flow-TEE.

15 In the embodiment of fig: 9 and 10, a crossblock 9g, 10 ("crossblock") forms the lower end of the lubricator 10, the crossblock's outerface 100 (9a, 10) is configured to act as the flange for the lower exit port 30, with associated sealing aperture, ring, and studs around its included port. The crossblock 90 has a vertical passageway 120 which receives and seals to the lower portion  
20 130 of the header 150 (or receives the lower end of a tubing 140 part of the header 150, 140, 130, 110 assembly, and this is roughly functionally equivalent to the lower part of the unibody header embodiment described above (without the crossblock). An upper part 110 of the header 150 combined with the tube 140 and crossblock 90 will have the same compact advantage of the preferred embodiment of the invention.

A flow restrictor, shown in Fig 9h may in an embodiment be installed within the crossblock 90  
25 in the horizontal bore of the crossblock between the lubricator bore and the vertical passageway 120 of the header's tube 140. The flow restrictor may be installed and serviced via an opened end (during servicing) of that horizontal crossblock bore.

A legend is provided here for ease of reference to the reference numbers in the Figures:

#	Component
10	lubricator
20	inner bore
30	exit port
40	internal passageways
50	seal sub
60	orifice plate
70	tubular-shaped insert
72	threaded external surface
73	threaded conduit
74	inner bore
80	adjustable valve means
82	handle
84	shaft
86	valve
88	removable plate
90	crossblock
100	outerface
110	upper portion of header
120	vertical passageway
130	lower portion of header
140	tube
150	header
160	servicing access

WHAT IS CLAIMED IS:

1. A plunger lift lubricator assembly comprising:
  - (a) a vertical, cylindrical lubricator comprising (i) a lubricator body having a lower end comprising a wellhead attachment flange, and defining a vertical longitudinal inner bore in fluid communication with an upper exit port and a lower exit port, and, said inner bore configured to receive a plunger travelling upwards into the lubricator through the lower end, and (ii) an upper lubricator assembly comprising an anvil, a removable spring cap, and a spring;
  - (b) a header disposed immediately adjacent and parallel to the lubricator body, the header defining a longitudinal bore in fluid communication with the lubricator inner bore through the lubricator upper exit port and the lubricator lower exit port, and defining a header exit port with attachment means to external fluid handling equipment.
2. The plunger lift lubricator assembly of claim 1, further comprising a flow restrictor installed between either or both of the lubricator upper and lower exit ports and the header.
3. The plunger lift lubricator assembly of claim 2, wherein the flow restrictor comprises a flow restriction plate with an orifice which chokes a fluid flow path from the lubricator into the header.
4. The plunger lift lubricator assembly of claim 2 or 3 wherein the flow restrictor comprises a seal sub having a fixed internal diameter, or a seal sub having a removable and replaceable orifice plate, an insert having an inside diameter smaller than the lubricator exit port, or a valve.
5. The plunger lift lubricator assembly of claim 4, wherein the seal sub has the valve, and the valve comprises a ball valve.

6. The plunger lift lubricator assembly of claim 1, configured to replace a conventional flow-tee having a horizontal dimension from a vertical centre line to the external fluid handling equipment, the assembly having a horizontal dimension from a vertical centre line of the lubricator inner bore to the header exit port attachment means which is selected to be the same as the flow-tee horizontal dimension.
7. The plunger lift lubricator assembly of claim 6, wherein the flow-tee has a vertical dimension from a flow-tee base to a horizontal centerline of a flow-tee exit port defined by a flange of the flow-tee for connection to the external fluid handling equipment; the lubricator assembly defines a vertical dimension from a base of the lubricator to a horizontal centerline of the header exit port; and the lubricator assembly vertical dimension is the same as the flow-tee vertical dimension.
8. The plunger lift lubricator assembly of claim 4, wherein the seal sub has the valve, and the valve is an adjustable valve.
9. The plunger lift lubricator assembly of claim 8, wherein the flow restrictor comprises a handle for adjusting the valve, wherein the handle is outside of the lubricator body and the header.
10. The plunger lift lubricator assembly of claim 4, wherein the seal sub is removably attached to the lubricator exit port by a threaded connection.
11. The plunger lift lubricator assembly of claim 2, wherein the lubricator body or the header defines an access port for access to the flow restrictor without disassembly of the lubricator and the header.
12. The plunger lift lubricator assembly of claim 11, wherein the flow restrictor is removable from the lubricator assembly via the access port without disassembly of the lubricator and the header.

13. A method of installing a lubricator in a wellhead, said wellhead comprising a flow-tee having a horizontal dimension from a vertical centre line to a flange for connecting to external fluid handling equipment, the method comprising the steps of:
  - (a) providing a lubricator assembly comprising:
    - (i) a lubricator comprising (a) a lubricator body defining a longitudinal inner bore in fluid communication with an upper exit port and a lower exit port, and (b) an upper lubricator assembly comprising an anvil, spring cap, and a spring, and
    - (ii) a header disposed adjacent and parallel to the lubricator body, the header defining a longitudinal bore in fluid communication with the lubricator inner bore through the lubricator upper exit port and the lubricator lower exit port, and defining a header exit port with attachment means to the external fluid handling equipment;
    - (iii) the lubricator assembly defining a horizontal dimension from the lubricator inner bore centre line to header exit port attachment means, which horizontal dimension is the same as the flow-tee horizontal dimension;
  - (b) removing the flow-tee and replacing it with the lubricator assembly which has the same horizontal dimension, without further modifying the wellhead to fit the lubricator assembly; and
  - (c) connecting the header exit port to the external fluid handling equipment.
14. The method of claim 13, wherein the lubricator assembly is part of a plunger lift system.
15. The method of claim 13 or 14, wherein replacing the flow-tee with lubricator assembly comprises attaching a well-head connection flange at a lower end of the lubricator assembly to the wellhead.

16. The method of claim 13, 14 or 15, wherein: the flow-tee has a vertical dimension from a flow-tee base to a horizontal centerline of a flow-tee exit port defined by the flow-tee flange; the lubricator assembly defines a vertical dimension from a lubricator base to a horizontal centerline of the header exit port; and the lubricator assembly vertical dimension is the same as the flow-tee vertical dimension.
17. The method of any one of claims 13-16, wherein the lubricator assembly further comprises a flow restrictor for restricting fluid flow through the lubricator upper exit port, or through the lubricator lower exit port.
18. The method of claim 17, wherein the flow restrictor comprises a plate or a tubular insert defining an orifice having an internal diameter less than an internal diameter of the lubricator upper exit port or the lubricator lower exit port.
19. The method of claim 17, wherein the flow restrictor comprises an adjustable valve.
20. The method of claim 19, wherein the flow restrictor comprises a handle for adjusting the valve, wherein the handle is outside of the lubricator body and the header.
21. The method of claim 17, wherein the flow restrictor comprises a seal sub having an internal diameter less than an internal diameter of the lubricator upper exit port or the lubricator lower exit port.
22. The method of claim 21, wherein the seal sub is removably attached to the lubricator exit port by a threaded connection.
23. The method of claim 21, wherein the flow restrictor further comprises a plate or a tubular insert disposed in the seal sub, removably attached to the seal sub, and defining an orifice having an internal diameter less than the seal sub internal diameter.
24. The method of claim 23, wherein the plate or the tubular insert is removably attached to the seal sub by a spring clip or by a threaded connection.

25. The method of any one of claims 21 to 24, wherein the flow restrictor further comprises an adjustable valve disposed in the seal sub.
26. The method of claim 25, wherein the flow restrictor comprises a handle for adjusting the valve, wherein the handle is outside of the lubricator body and the header
27. The method of any one of claims 17 to 26, wherein the lubricator body or the header defines an access port for access to the flow restrictor without disassembly of the lubricator and the header.
28. The method of claim 27, wherein the flow restrictor is removable from the lubricator assembly via the access port without disassembly of the lubricator and the header.
29. A plunger lift lubricator assembly comprising:
  - (a) a crossblock configured to attach to a wellhead, the crossblock having a vertical internal bore with an inlet and an upper lubricator port, a horizontal bore connected to the vertical bore and having an exit port, and a vertical passageway connecting the horizontal bore to a header port;
  - (b) a lubricator connected to the crossblock and comprising (i) a lubricator body defining a vertical longitudinal inner bore in fluid communication with an upper exit port and the crossblock upper lubricator port, said inner bore configured to receive a plunger travelling upwards into the lubricator through the crossblock vertical bore, and (ii) an upper lubricator assembly comprising an anvil, a removable spring cap, and a spring;
  - (c) a header disposed adjacent to the lubricator body and connected to the crossblock, the header defining a longitudinal bore in fluid communication with the lubricator upper exit port and the crossblock header port.

30. The plunger lift lubricator assembly of claim 29, further comprising a flow restrictor installed in the crossblock horizontal bore, between the vertical bore and the header vertical passageway.
31. The plunger lift lubricator assembly of claim 30, wherein the flow restrictor comprises a flow restriction plate with an orifice which chokes a fluid flow path through the horizontal bore.
32. A method of installing a lubricator in a wellhead, said wellhead comprising a flow-block or flow-tee having a horizontal dimension from a vertical centre line to a flange for connecting to external fluid handling equipment, the method comprising the steps of:
  - (a) providing a lubricator assembly comprising:
    - (i) a crossblock configured to attach to a wellhead, the crossblock having a vertical internal bore with an inlet and an upper lubricator port, a horizontal bore connected to the vertical bore and having an exit port, and a vertical passageway connecting the horizontal bore to a header port;
    - (ii) a lubricator connected to the crossblock and comprising a lubricator body defining a vertical longitudinal inner bore in fluid communication with an upper exit port and the crossblock upper lubricator port, said inner bore configured to receive a plunger travelling upwards into the lubricator through the crossblock vertical bore, and an upper lubricator assembly comprising an anvil, a removable spring cap, and a spring;
    - (iii) a header disposed adjacent to the lubricator body and connected to the crossblock, the header defining a longitudinal bore in fluid communication with the lubricator upper exit port and header port;
    - (iv) the lubricator assembly defining a horizontal dimension from a lubricator inner bore centre line to the cross-block exit port, which horizontal dimension is the same as the flow-block or flow-tee horizontal dimension;

- (b) removing the flow-block or flow-tee and replacing it with the lubricator assembly which has the same horizontal dimension, without further modifying the wellhead to fit the lubricator assembly; and
- (c) connecting the cross-block exit port to the external fluid handling equipment.

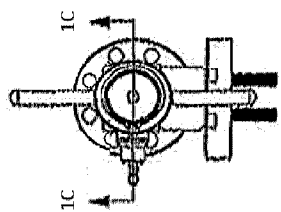

FIG. 1D

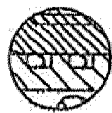

FIG. 1E

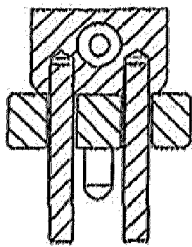

FIG. 1G

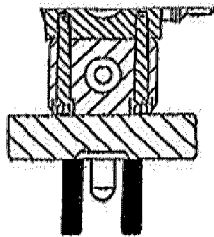

FIG. 1H

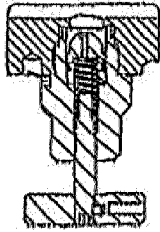

FIG. 1J

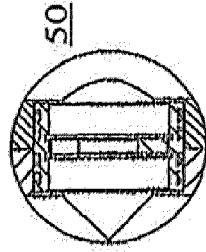

FIG. 1K

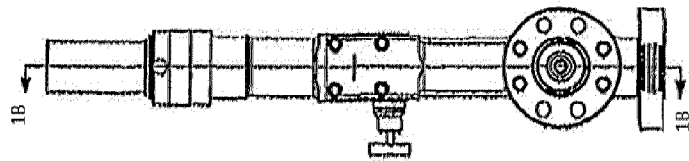

FIG. 1A

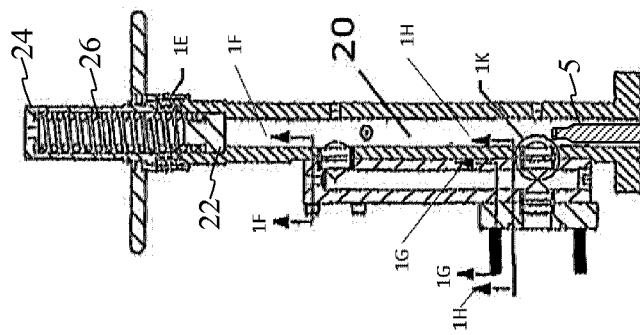

FIG. 1B

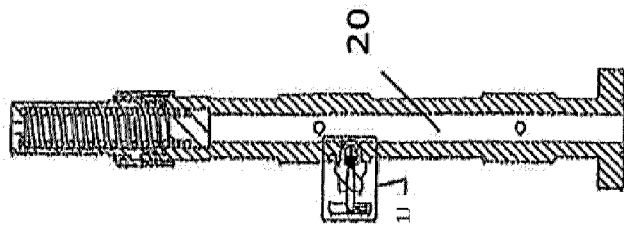

FIG. 1C

FIG. 1

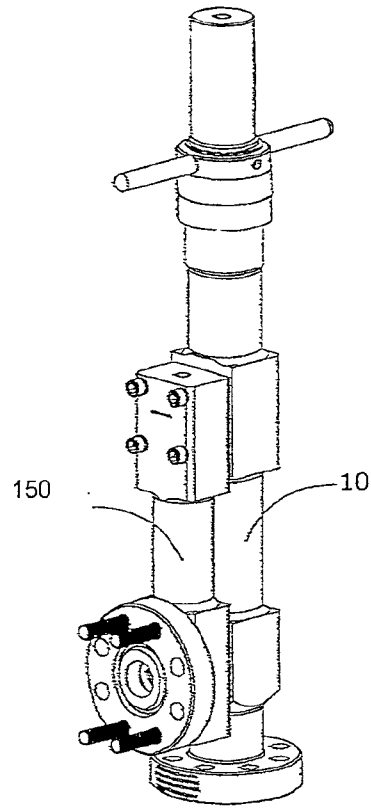

Fig. 2

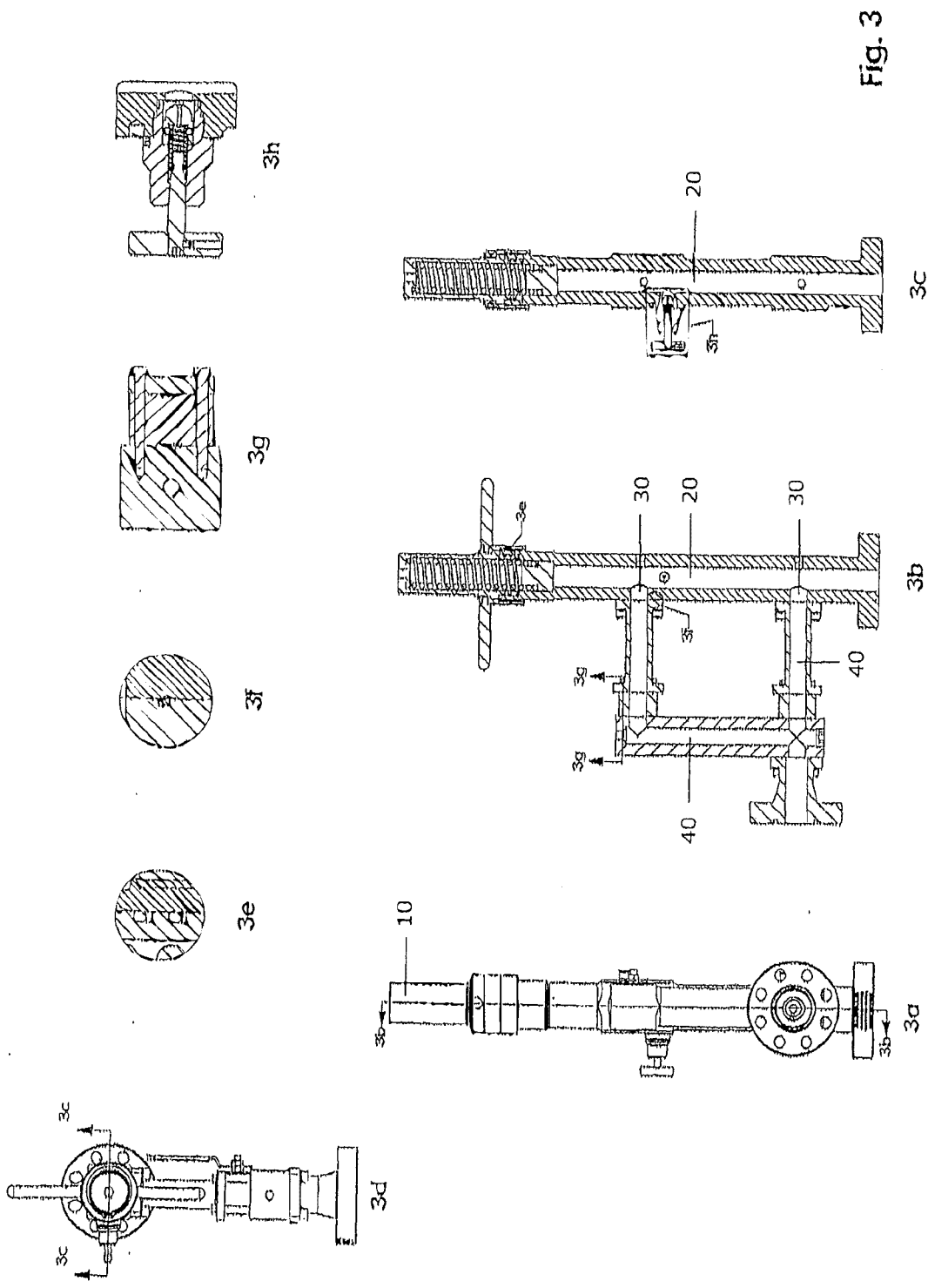

Fig. 3

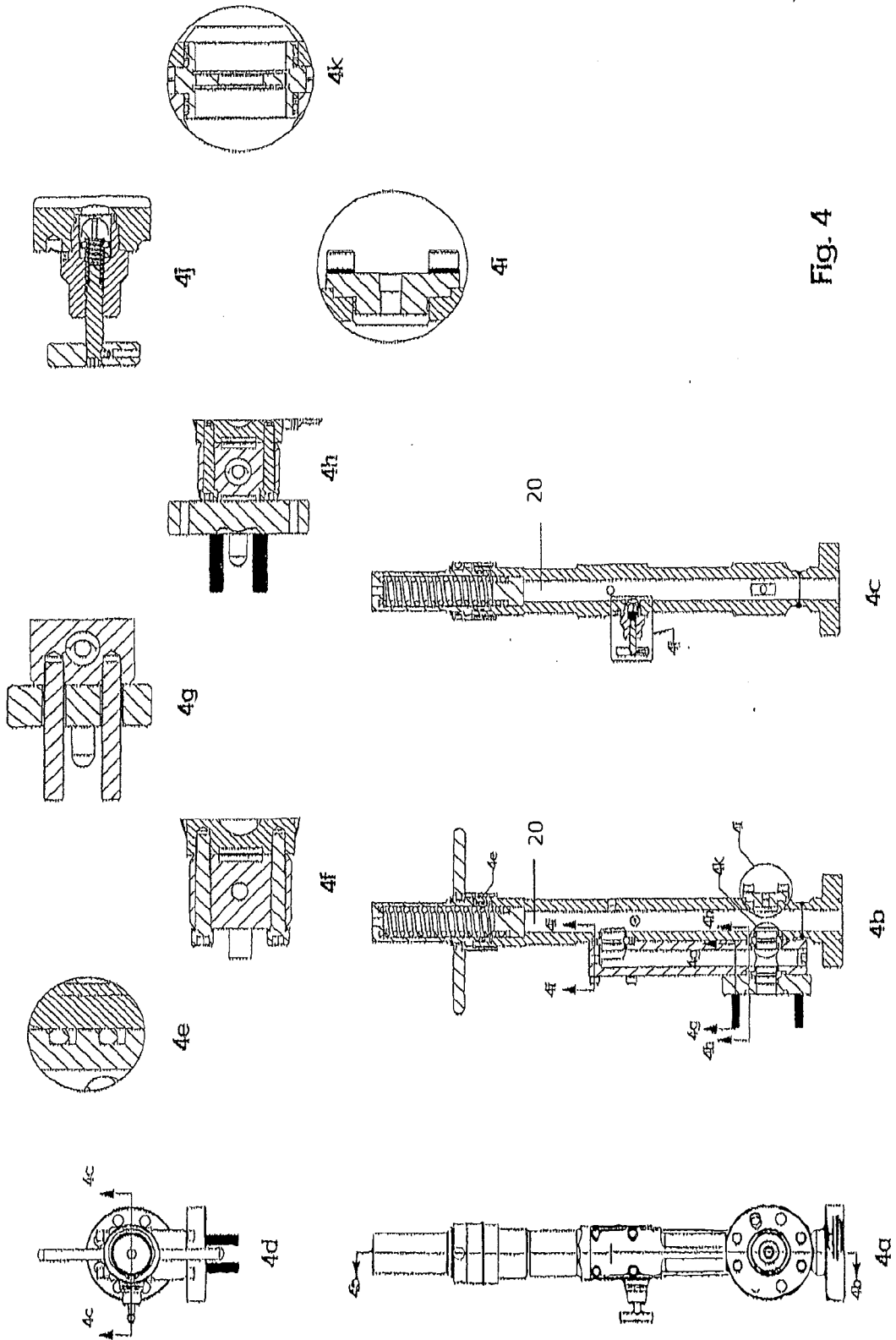

Fig. 4

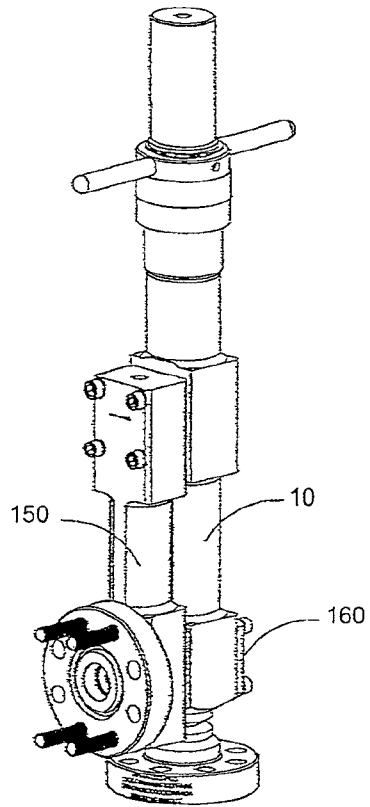

Fig. 5

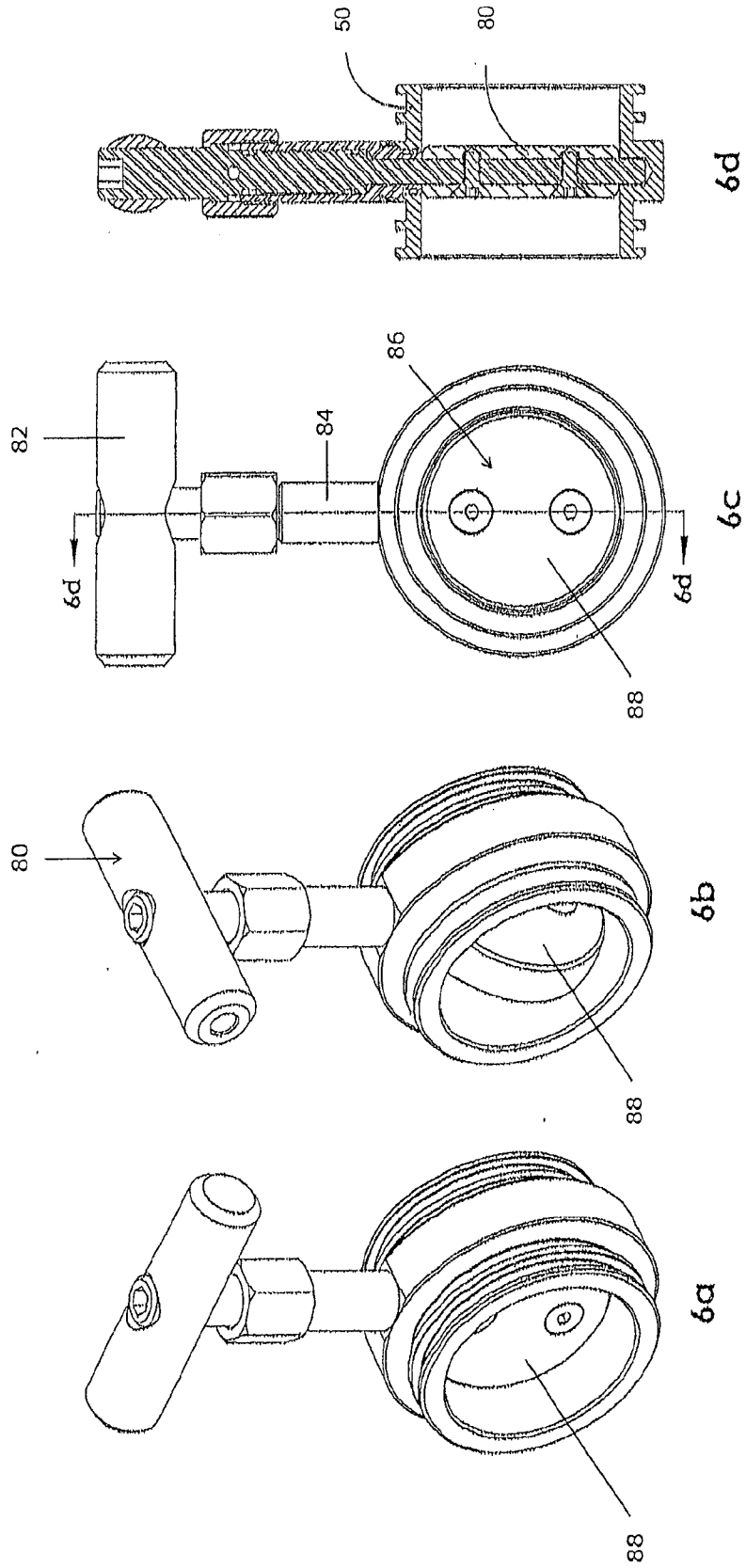

FIG. 6

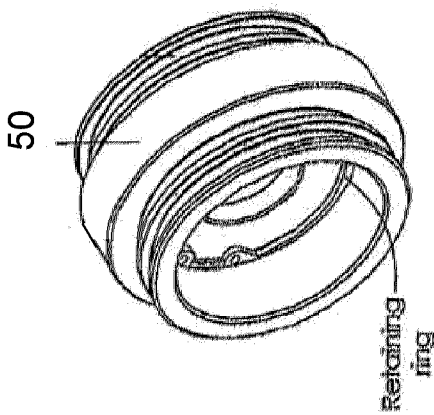

FIG. 7A

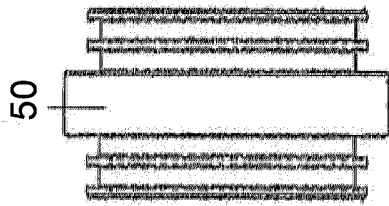

FIG. 7B

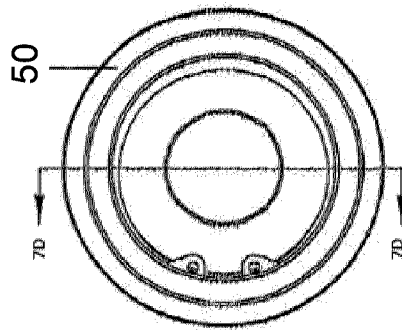

FIG. 7C

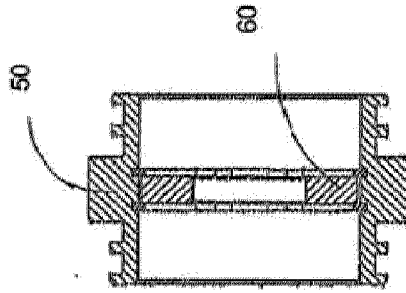

FIG. 7D

FIG. 7

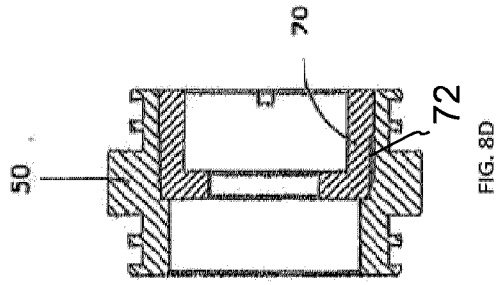

FIG. 8D

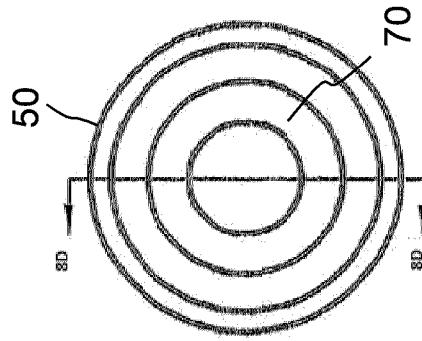

FIG. 8C

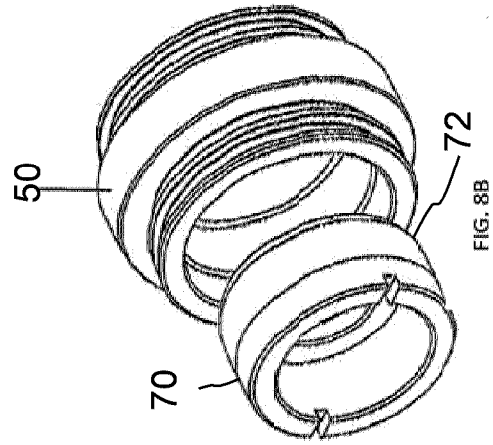

FIG. 8B

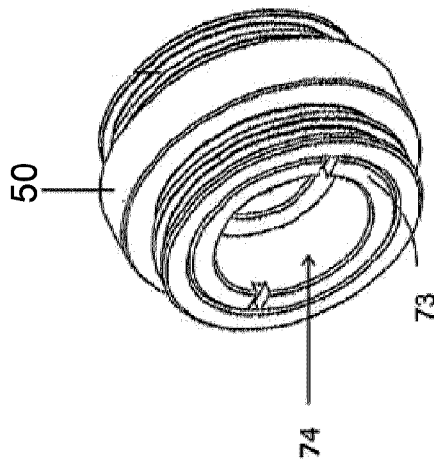

FIG. 8A

FIG. 8

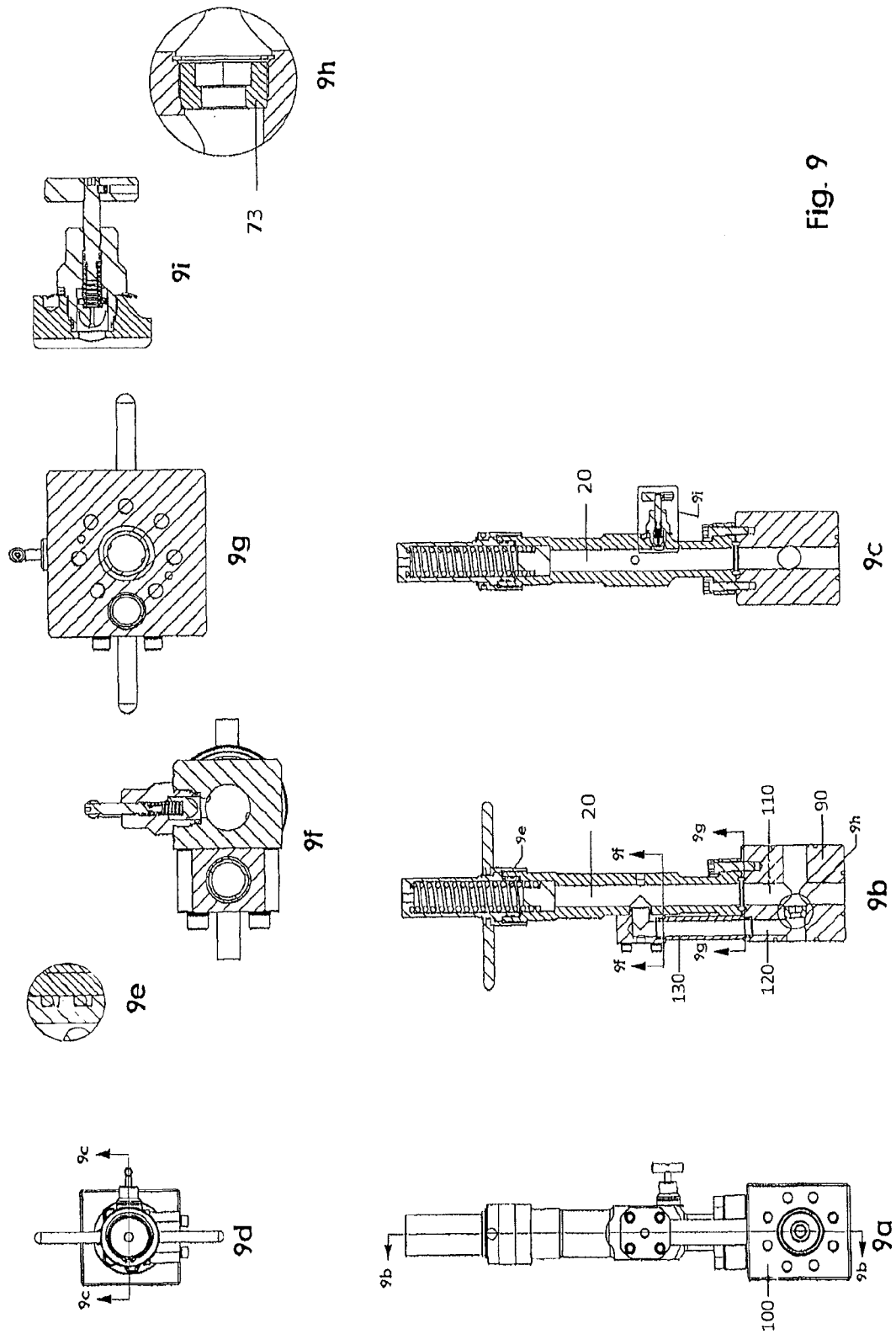

Fig. 9

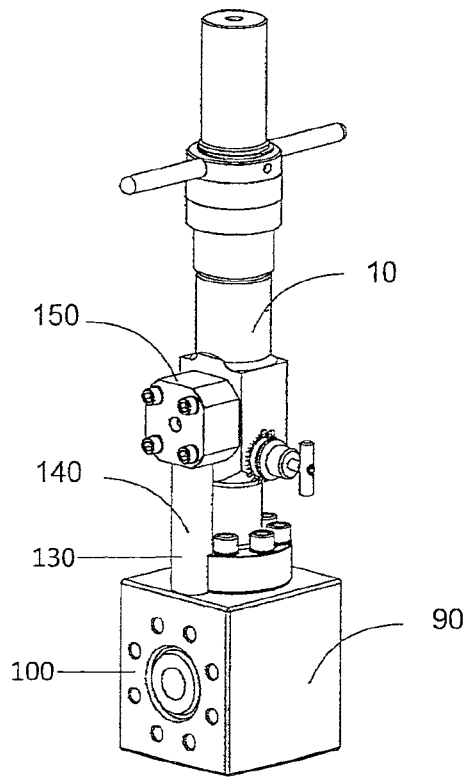
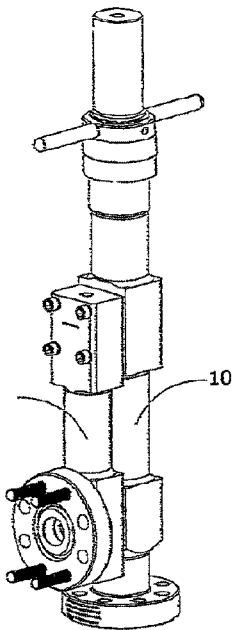

Fig. 10

150



10