



April 10, 1962

J. O. MCGUIRE

3,029,106

SURGEON'S OPERATING CHAIR

Filed May 13, 1959

2 Sheets-Sheet 2

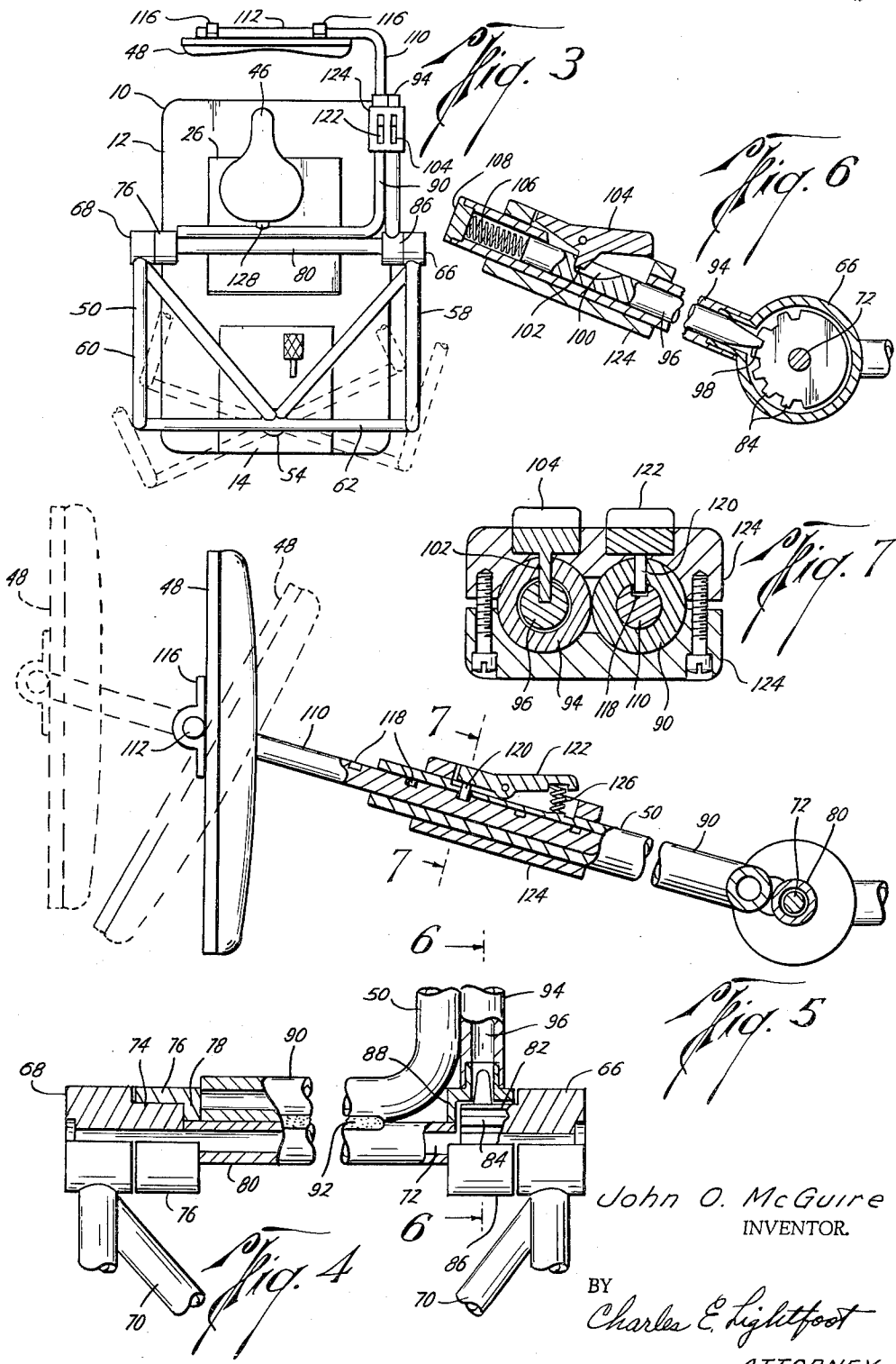

John O. McGuire  
INVENTOR.

BY  
Charles E. Lightfoot  
ATTORNEY

1

3,029,106

**SURGEON'S OPERATING CHAIR**

John O. McGuire, 713 W. 38th St., Houston, Tex.

Filed May 13, 1959, Ser. No. 812,991

3 Claims. (Cl. 297-217)

This invention relates to an operating chair for use by surgeons and more particularly to a combined seat and chest support device for supporting a person in a comfortable position while performing a surgical operation.

In performing surgical operations it is customary to support the patient on an operating table in a position easily accessible to the surgeon who usually stands at one side of the table. Operating tables for surgical use are ordinarily of highly complex construction, equipped with numerous devices to enable the patient's position to be adjusted in any desired manner and to facilitate the performance of various procedures during the course of the operation. Much of the equipment of the operating table is located below the top of the table leaving no convenient space into which the surgeon's feet and legs may extend beneath the top of the table, so that the surgeon must lean forward over the table in an unrelaxed and uncomfortable position in performing the operation. At times, and particularly under circumstances which require an operation of long duration, the position in which the surgeon is thus compelled to hold himself often becomes very painful resulting in great inconvenience and fatigue.

The present invention has for an important object the overcoming of the above disadvantages by the provision of a surgeon's operating chair which may be used by the surgeon to support himself in a convenient and relaxed position for carrying out the operation.

Another object of the invention is to provide a surgeon's operating chair which is easily moved about to locate the chair in any desired position to properly support the surgeon, and embodying means for holding the chair against accidental shifting while the surgeon is performing the operation.

A further object of the invention is the provision of a surgeon's operating chair having a seat which may be adjusted to support the surgeon at any desired height above the floor and also having a body engaging member which may be adjusted to support the surgeon in a relaxed position relative to the patient during the performance of the operation.

Another object of the invention is to provide a surgeon's operating chair which is supported for free swinging movement about a vertical axis to permit the surgeon to easily move his body from side to side while at the same time securely supporting himself at a desired elevation and in a comfortable position relative to the patient.

A further object of the invention is the provision of a combined seat and body support of the kind mentioned embodying hydraulic mechanism for elevating and lowering the same which may be easily and quickly operated by the surgeon to position himself in a comfortable and relaxed position for carrying out the operation.

Another object of the invention is to provide a surgeon's operating chair which is constructed to permit the surgeon to position himself thereon without using his hands or otherwise risking the danger of contamination from contact with unsterilized equipment.

A further object of the invention is the provision of a surgeon's operating chair which may be covered with a sterilized cover and in which the various adjustments of the chair may be made under sterile conditions without danger of contamination.

A still further object of the invention is to provide a

2

surgeon's operating chair which is of simple design and rugged construction capable of withstanding the conditions of hard usage to which devices of this character are likely to be subjected.

5 The above and other important objects and advantages of the invention may best be understood from the following detailed description, constituting a specification of the same, when considered in conjunction with the annexed drawings, wherein—

10 FIGURE 1 is a perspective view of a preferred embodiment of the invention;

FIGURE 2 is a fragmentary, vertical, central, cross-sectional view, on a somewhat enlarged scale, of the invention as illustrated in FIGURE 1, showing details of structure of the mechanism by which the chair may be moved about and the hydraulic elevating and lowering mechanism of the same;

FIGURE 3 is a top plan view of the invention as illustrated in FIGURE 1;

20 FIGURE 4 is a fragmentary, top plan view, partly broken away and partly in cross-section and in a somewhat enlarged scale of the supporting and adjusting mechanism for the body-engaging member of the invention;

25 FIGURE 5 is a fragmentary side elevation view, partly broken away and partly in cross-section and on a somewhat enlarged scale, showing structural details of the body-engaging member and its supporting and adjusting mechanism;

30 FIGURE 6 is a cross-sectional view, taken along the line 6-6 of FIGURE 4, looking in the direction indicated by the arrows; and

FIGURE 7 is a cross-sectional view, on an enlarged scale, taken along the line 7-7 of FIGURE 5, looking in the direction indicated by the arrows.

35 Referring now to the drawings in greater detail, the invention comprises a generally rectangular supporting base, generally designated by the numeral 10 of inverted tray shape, whose bottom wall provides a platform 12, and which has near one end an upstanding hollow projection, or housing, 14, whose interior is divided by a partition 16, to form an upper chamber 18 for the accommodation of hydraulic lift mechanism, and a lower chamber 20 which serves as a reservoir for hydraulic fluid to be supplied to the lift mechanism. The base is supported on wheels or coasters 22 and 24 of which the wheels 22 may be of the swivel type to permit the base to be easily rolled about.

40 Suitable braking mechanism is provided and it may take the form of a foot plate 26, hingedly mounted along one edge, as by means of the shaft 28 to the platform 12 for vertical swinging movement, and connected by a link 30 extending downwardly through an opening 32 in the platform to a bell crank 34, pivotally supported on the base and which is in turn connected to a brake rod 36 which carries a brake shoe 38, positioned for engagement with the wheel 24 when the foot brake is depressed, to hold the wheel against rotation. The brake rod 36 extends through and is slidably supported on a lug or cross-wall 40 on the base and is provided with a coil spring 42, which bears at one end on the cross-wall 40, and whose other end bears against a washer 44 fixed to the rod in position to urge the brake rod in a direction to release the brake and to elevate the foot plate 26. It will be apparent that when a person using the chair stands on the foot plate 26, the brake will be applied to prevent the rolling of the device, and when the user raises his feet or steps out of the chair, the brake will be released to permit the device to be readily rolled about.

70 The invention includes a seat 46 and a body engaging member 48, which are carried on a supporting frame, generally designated 50, which is attached to and extends

upwardly from a plunger 54 slidably extended through the upper wall of the housing 14, and which works in a pressure cylinder 56 disposed in the chamber 18, whereby the frame may be raised and lowered to adjust the elevation of the seat and body engaging member.

The frame 50 has laterally spaced apart side arms 58 and 60, connected together by means of a cross bar 62, which is provided centrally with a downwardly vertically extending post 64, which is attached at its lower end to the upper end of the plunger 54 as by means of welding or otherwise, and these side arms are formed at their free ends with external enlargements 66 and 68 respectively, which serve as bearings in a manner to be more fully explained hereinafter. Braces 70 are provided on the frame which are connected at their upper ends to enlargements 66 and 68 and which extend downwardly for connection at their lower ends to the upper end of the plunger 54 adjacent the post 64 to securely support the frame on the plunger. The enlargements or bearings 66 and 68 are connected by a shaft 72, which extends through horizontally aligned central openings in each of the enlargements, and is non-rotatably fixed thereto in any suitable manner, as by welding or the like.

The enlargement or bearing 68 has inwardly extending externally reduced bearing portion 74, upon which a cylindrical element 76 is rotatably mounted, which element has an inturned flange 78 forming an opening into which one end of a tubular element 80 is extended, and which rotatably surrounds the shaft 72, as best seen in FIGURES 4 and 5. The enlargement or bearing 66 is provided with an inwardly extending externally reduced bearing portion 82, which is provided with external teeth 84, and upon which a cylindrical element 86 is rotatably mounted, which element has an inturned flange 88 forming a central opening into which the other end of the tubular element 80 is extended. A tubular frame element 90 is provided which is of angular shape having one arm thereof lying parallel to and attached to the tubular element 80 as by means of welding, as shown at 92 in FIGURE 4, for rotation with the element 80, and the other arm thereof extending away from the element 80.

Another tubular frame element 94 is connected at one end to the cylindrical element 82 and extends outwardly parallel to the arm of the frame element 90, which extends away from the tubular member 80, and within this element or arm 94 of the frame a detent 96 is slidably positioned, and is formed at one end with a tapered end portion 98, positioned to be engaged with the teeth 84 of the reduced portion 82 of the enlargement 66 to hold the cylindrical element 82 and the frame member 94 against rotational movement relative to the enlargement 66. The detent 96 is provided with a notch 100, into which an arm 102 of a pivotally mounted latch 104, carried by the frame member 94, may extend for engagement with the detent to move the detent out of engagement with the teeth 84 when the latch member 104 is depressed to permit the tubular member 82 and arm 94 to be rotated about the bearing portion 82 of the enlargement 66 to adjust the position of the frame members 90 and 94. A coil spring 106 is disposed within the arm 94, in engagement with a closure 108 enclosing the outer end of the arm and whose inner end bears against the outer end of the detent 96 to yieldingly urge the detent into engagement with the teeth 84. Upon depression of the latch member 104, the arm 102 will engage the detent in the notch 100 to move the detent 96 in engagement with the teeth 84 against the pressure of the spring 106, and upon release of the latch member 104, the spring 106 will move the detent back into engagement with the teeth 84 and at the same time elevate the latch member 104.

The outer end of the outwardly extending arm of the frame member 50 is open and one arm 110 of an angle shaped extension member, in the form of a rod, is slidably extended into the outer end of the frame member 90. The other arm 112 of the extension member carries

the body engaging member 48 which may be of flat plate-like construction, rotatably mounted on the arm 112 as by means of suitable bearings 116, to position the body engaging member in parallel spaced relation to the member 80 of the frame. The body engaging member is preferably provided with a suitable pad or cushion positioned against which the body of the user may rest, when the user is seated on the seat 46. The arm 110 of the extension member is provided with suitable notches or recesses 118 into which a pin 120 carried on a latch member 122 may extend to hold the arm 110 against sliding movement on the outwardly extending arm of the member 90. The latch member 122 is pivotally mounted on the member 90 as by means of a two-part clamp 124, detachably secured to the frame members 90 and 94, as best seen in FIGURE 7, and upon which the latch member 104 is also mounted.

The bearings 116 are preferably located somewhat above the midportion of the member 112 so that the body engaging member always hangs in a vertical position ready for engagement with the body of a person seated on the seat.

It will be apparent that by depressing the latch member 122, the pin 120 may be lifted out of latching engagement with the arm 110 to permit the arm to be moved inwardly or outwardly of the frame member 94, to adjust the position of the body engaging member 48, toward or away from the frame, and that upon release of the latch member 122, the coil spring 126 will return the latch member to a position with the pin 120 extending into one of the notches 118 to securely hold the body engaging member in its adjusted position.

The seat 46 may be of bicycle type, adjustably mounted on a shaft 128 attached to the frame member 90 and extending toward the body engaging member 48.

The plunger 54 is slidably extended into the hydraulic cylinder 56 through an opening in the top of the housing 14 and suitable packing, such as that indicated at 130, may be provided between the plunger and the housing to form a fluid tight seal. Within the chamber 18 of the housing 14, the hydraulic cylinder 56 is provided with an inlet connection 132 and an outlet connection 134. The inlet connection leading to the discharge outlet of a pump cylinder 136, provided with the usual outlet valve 138, and the cylinder being also connected by an inlet pipe 140 with the interior of the supply reservoir chamber 20, which inlet pipe has an inlet valve 142 of the usual type. The outlet connection 134 of the cylinder 56 leads to the interior of the hydraulic fluid supply reservoir 20, under the control of a valve 144. The supply reservoir 20 has an inlet opening 146 which is provided with a suitable closure such as the screw plug 148 which may be removed to permit the reservoir to be filled with hydraulic fluid.

Within the pump cylinder 136, a plunger 150 is located which is connected to a pivotally mounted foot pedal 152, as by means of a connecting rod 154 whereby the plunger may be moved downwardly by the user and the foot pedal is urged upwardly by means of a coil spring 156 to return the plunger to its uppermost position in the pump cylinder. The valve 144 of the outlet connection of the cylinder 56 has an operating arm 158 which is connected to a shaft 160 which is positioned to be engaged by the foot pedal to open the valve 144 when the pedal reaches the lower limit of its downward movement, the valve 144 being of the spring type, adapted to close when the pedal 152 moves upwardly out of engagement with the shaft 160.

In the operation of the hydraulic mechanism to elevate the plunger 54 and the supporting frame 50 therewith, the foot pedal 152 is depressed by the user, which results in downward movement of the plunger 150 in the pump cylinder 136, to close the intake valve 142 and open the discharge valve 138 to supply hydraulic fluid under pressure from the reservoir 20 to the lower end of the pressure cylinder 56 beneath the plunger 54 to move the plunger upwardly. Upon upward movement

5

of the pedal 152 under the influence of the spring 156, the plunger 150 moves upwardly in the pump cylinder 136, to cause the discharge valve 138 to close and the intake valve 142 to open to allow fluid from the reservoir 20 to enter the pump cylinder. By repeatedly depressing the pedal 152, hydraulic fluid from the reservoir 20 may thus be pumped into the pressure cylinder 56 beneath the plunger 54 to elevate the supporting frame to any desired height. During the pumping operation, the valve 144 will be closed and when it is desired to lower the supporting frame, the pedal 152 is depressed to the lower limit of its downward movement to engage the shaft 160 to move the same downwardly to open the valve 144, whereupon hydraulic fluid in the pressure cylinder 56 beneath the plunger 54 may flow back to the reservoir 20 through the outlet connection 134.

In making use of the operating chair of the invention, the surgeon may position himself on the seat by standing on the platform 12 without touching any part of the apparatus with this hand, and may elevate the seat and body engaging member to the desired height by depressing the pedal 152 with his foot. It will also be apparent that the chair may be covered with a sterilized sheet or other covering, through which the latch members 104 and 122 may be conveniently operated to adjust the angular position of the body engaging member relative to the supporting frame as well as the distance between the body engaging member and the seat, so that the surgeon may lean forward against the body engaging member and be supported by the apparatus in a comfortable and relaxed position for operating on the patient. Moreover, it will be apparent that the plunger 54 may rotate freely about its axis relative to the base, so that the surgeon may turn from side to side to any desired position.

During the course of the operation, the surgeon's feet will normally be resting on the foot plate 26, to depress the same to engage the brake 38 with the wheel 24 to hold the chair in a stationary position, and in the event that the surgeon should desire to shift the chair from one position to another, this may be easily accomplished by releasing the foot plate 26 to release the brake, whereupon the chair may be rolled to the desired position and the brake again applied by depressing the foot plate.

The invention, constructed and operated as described above, provides a surgeon's operating chair of strong and rugged construction, and which is easily operated by the surgeon without danger of contamination, by which the surgeon will at all times be supported in a relaxed and comfortable position.

The invention is disclosed herein in connection with a certain specific embodiment of the same, but it will be understood that this is intended by way of illustration only, and that various changes may be made in the construction and arrangement of the parts within the spirit of the invention and the scope of the appended claims.

Having thus clearly shown and described the invention, what is claimed as new and desired to secure by Letters Patent is:

1. In a surgeon's operating chair a supporting frame,

6

a base adapted to be positioned on the floor at one side of an operating table, means for movably supporting the frame on the base for vertical movement along and rotation about a vertical axis, a seat supported on and extending horizontally outwardly from the frame and a body engaging member movably mounted on the frame in horizontally outwardly spaced relation to said seat for rotational movement about a horizontal axis.

2. In a surgeon's operating chair a supporting frame of generally rectangular shape, a base adapted to be positioned on the floor at one side of an operating table, means for movably supporting the frame on the base for vertical movement in a horizontal position along and rotation about a vertical axis, a seat supported on and extending horizontally outwardly from one side of the frame, a support element of angle shape, means movably supporting the element on the frame with one arm of the element extending outwardly from one end of said one side at right angles thereto and the other arm thereof extending parallel to said one side for vertical swinging movement relative to the frame in forwardly spaced relation to said seat and a body engaging member rotatably mounted on said other arm for vertical swinging movement in parallel relation thereto.

3. In a surgeon's operating chair a supporting frame of generally rectangular shape, a base adapted to be positioned on the floor at one side of an operating table, means for movably supporting the frame on the base for vertical movement in a horizontal position along and rotation about a vertical axis, a seat supported on and extending horizontally outwardly from one side of the frame, a support element of angle shape, means movably supporting the element on the frame with one arm of the element extending outwardly from one end of said one side at right angles thereto and the other arm thereof extending horizontally for movement toward and away from said one side to allow said other arm to be positioned in forwardly spaced relation to said seat and a body engaging member rotatably mounted on said other arm for vertical swinging movement in parallel relation thereto.

#### References Cited in the file of this patent

##### UNITED STATES PATENTS

45	1,721,221	Jauregui -----	July 16, 1929
	1,933,421	Elliotte -----	Oct. 31, 1933
	2,375,696	Shick -----	May 8, 1945
	2,545,813	Jackson -----	Mar. 20, 1951
	2,568,988	Childs -----	Sept. 25, 1951
50	2,579,606	Oom et al. -----	Dec. 25, 1951
	2,609,862	Pratt -----	Sept. 9, 1952
	2,613,725	Woodhall -----	Oct. 14, 1952
	2,865,429	Thompson -----	Dec. 23, 1958

##### FOREIGN PATENTS

55	623,702	Great Britain -----	May 20, 1949
----	---------	---------------------	--------------