

No. 871,751.

PATENTED NOV. 19, 1907.

W. N. BEST.
AIR CARBURETING OIL BURNER.
APPLICATION FILED FEB. 17, 1903.

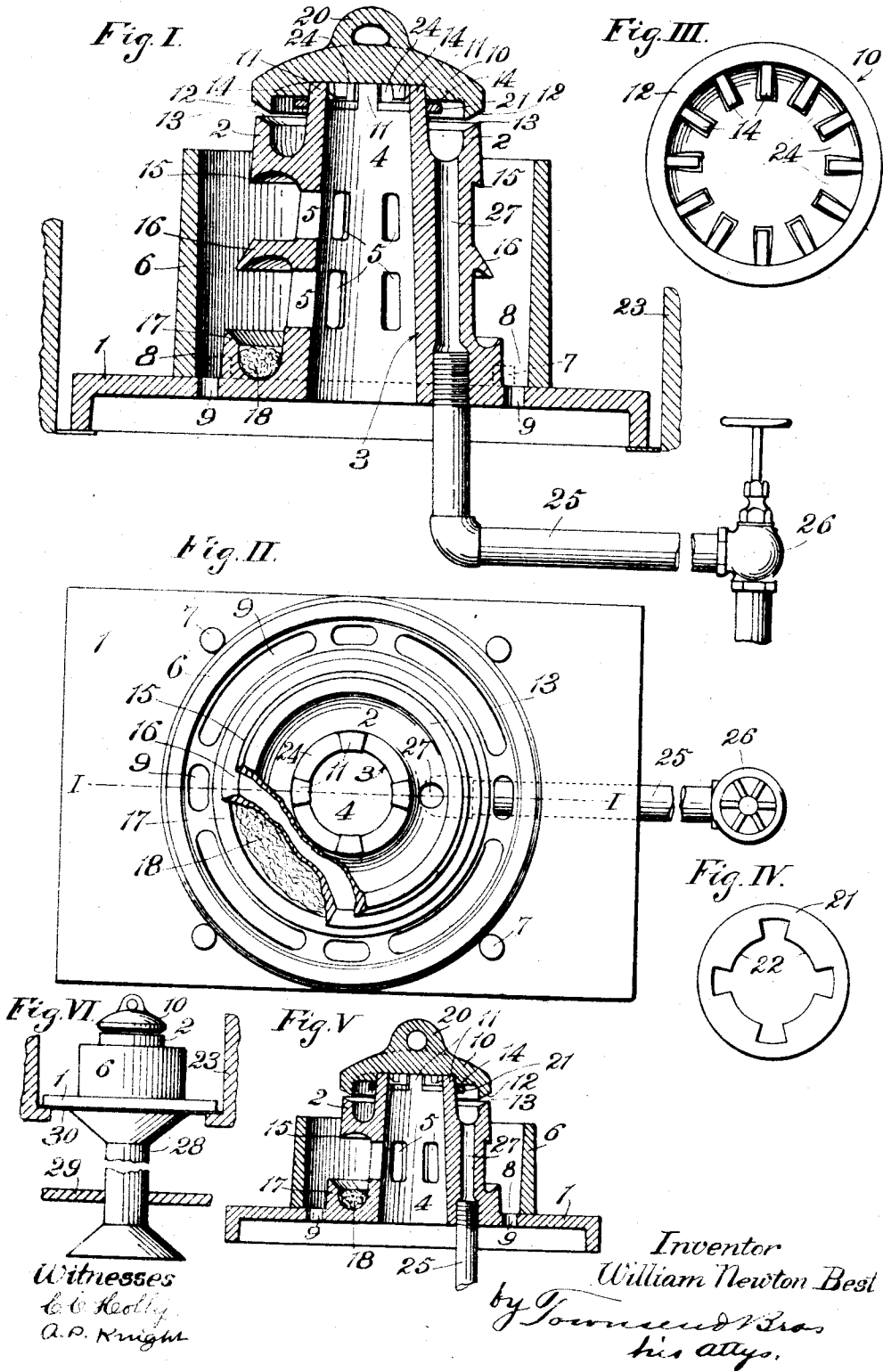

Witnesses
C. C. Kelly
A. P. Knight

Inventor
William Newton Best
by Townsend & Best
his attys.

UNITED STATES PATENT OFFICE.

WILLIAM NEWTON BEST, OF LOS ANGELES, CALIFORNIA, ASSIGNOR TO JOHN H. BEST AND EZRA BEST, OF QUINCY, ILLINOIS.

AIR-CARBURETING OIL-BURNER.

No. 871,751.

Specification of Letters Patent.

Patented Nov. 19, 1907.

Application filed February 17, 1903. Serial No. 143,851.

To all whom it may concern:

Be it known that I, WILLIAM NEWTON BEST, a citizen of the United States, residing at Los Angeles, in the county of Los Angeles and State of California, have invented a new and useful Air-Carbureting Oil-Burner, of which the following is a specification.

The object of this invention is to provide an improved and superior burner for volatile oils, such as petroleum distillate, its superiority over the burners now in use consisting in more complete combustion and the resulting greater efficiency and freedom from smell and from deposition of oil vapor.

A further object of my invention is to produce such complete combustion by the use of natural draft, as distinguished from forced draft, and by providing for combustion of a carbureted air mixture as distinguished from combustion of oil vapor.

My invention further provides for the vaporization and combustion of any temporary excess of oil supply.

The above objects are attained by a construction which supplies air, by natural draft interiorly of the oil vaporizing receptacle, so that the air becomes carbureted or mixed with the oil vapor at the moment of gasification, or vaporization, and the combustion is therefore of a mixture of gas and air and not of vapor issuing into air. When oil is vaporized and is then allowed to issue into and burn in air, a smoky, inefficient flame results, whereas the mixture aforesaid burns with a smokeless hot flame. Such a flame has heretofore been produced by the mixing effect of a forced draft, and my invention is primarily directed to attaining this result by use of a natural draft.

My invention is particularly applicable for use in household stoves where natural draft exists, while forced draft is difficult to obtain.

Further objects of my invention relate to means for regulating the air supply and to other details as hereinafter set forth.

One of such further objects of this invention is to provide means whereby a draft of air can be supplied to the burner from beneath the burner as herein described so that a supply of air can be given the burner when the lid of a stove or door of a furnace, etc., is opened, which would otherwise spoil the vacuum and cause the interior of the stove, furnace, etc., to become sooted upon the in-

terior and a volume of unconsumed gas to escape from the stack. The shape, form and size of this draft flue conforms to the requirements in the places used.

The accompanying drawings illustrate the invention.

Figure I is a vertical section on the line I—I in Fig. II, of an embodiment of my invention. Fig. II is a plan of the burner with the cap removed and with parts broken away. Fig. III is an inverted plan of the burner cap. Fig. IV is a plan of a draft regulating washer or ring. Fig. V shows another embodiment of my invention. Fig. VI shows an auxiliary draft attachment for the burner.

Referring to Figs. I and II, 1 designates a suitable base adapted to rest on the grate of a stove or other suitable support. An oil cup or open-topped oil receptacle 2 is formed on the top of a tubular support 3 which extends upwardly from base 1 and has an interior passage 4 extending through the oil receptacle, said oil receptacle being formed as an annular cup surrounding said passage. Lateral perforations 5 extend through this tubular support. Surrounding the tubular support 3 is a rim or wall 6 which is desirably loose or removable, resting on the base 1 and held in place by pins or lugs 7 on said base. The space between said rim 6 and tubular support 3 forms an exterior passage 8 which extends upwardly around the tubular support and around the oil cup, and air passages or holes 9 are provided in the base 1 communicating with said outer passage 8.

A deflecting cap 10 resting on upward projections or lugs 11 on top of the tubular support 3 extends over the inner passage 4 and completely over the oil cup to the outer edge thereof forming a contracted annular opening or passage between the downturned external lip 12 of the cap and the upturned edge, rim or lip 13 of the oil cup, so as to deflect the air from the inner passage over the oil in the cup and out through said annular opening. The air passes from the inner passage 4 to the vaporizing chamber or space over the oil cup, through the openings or spaces 24 between the lugs 11. The cap 10 is provided with lugs 14 on its under side which engage outside of lugs 11 to hold the cap in central position, these lugs 14 being sufficiently numerous and close to engage lugs 11 in all rotative positions of the cap while allowing free draft passage between

them. The cap 10 resting freely on the tubular support 3 is readily removable and replaceable and it is desirably provided with a ring or lug 20 to enable it to be readily lifted and removed.

An oil supply pipe 25 controlled by a cock or valve 26 leads to a passage 27 formed in the tubular support 3, said passage communicating with the annular oil cup 2.

The external rim, lip or flange 13 of the oil cup desirably flares downwardly on its periphery and its lower edge droops or has a bead or downturned rib as shown at 15, whereby any oil that may run over said lip will drip off at said drooping edge instead of running in to the tubular support. Directly beneath this external lip 13 is a ring or flange 16 formed on the tubular support and acting as a distributor and deflector for oil that drips from said edge. This flange or ring 16 also desirably flares on its peripheral surface, and below it is arranged an annular drip cup or catch-basin 17. A wick 18 of asbestos may be placed in said catch-basin to assist in starting the burner.

21 designates a ring or washer that may be placed on top the tubular support 3 to partly close the opening between the latter and the cap 10, this washer being provided with lugs 22 that fit in between the lugs 11 to hold the ring 21 in position.

While the burner above described operates satisfactorily, burning with a clear flame when the stove is closed, it is liable to smoke somewhat when a stove lid is removed, owing to diminution of suction and consequent decrease in flow of air between the oil cup and the cap. This may be remedied by the provision of an auxiliary draft flue 28 shown in Fig. VI extending from beneath the burner base 1 to some distance below the stove, for example, through the floor 29 into the cellar or room below. This auxiliary draft flue being attached to a plate 30 on which the burner base rests, becomes heated by conduction and an upward draft is produced therein which will maintain a flow of air through the burner sufficient to produce the carbureting effect even when the stove is opened.

In use, the burner will generally be placed in a stove or fire-pot, indicated at 23 in Fig. I, its base 1 acting as a closure for said fire-pot so as to force all the natural draft of the stove to pass through the burner passages. Oil being turned on till the cup 2 is full and preferably overflows, it is lighted at any convenient point, for example, at the wick 18 if the latter be used. The flame quickly heats the tubular support 3, cap 10 and inclosing ring 6 and the regular combustion of the burner will then proceed. The greater part of the incoming air will pass up through the inner air passage 4 and will be deflected by the cap 10 so as to pass over the oil in the

cup 2 and out through the annular opening between the external lips of the cap 10 and the oil cup, and the oil vapor which arises from the oil in the cup is instantly mixed with and carried out by this current of air. The mixture that thus passes out from beneath the deflecting cap, meets the current of air passing upwardly in the outer passage 8 and is deflected upwardly, burning with a cup-shaped, clear, hot flame.

It will be understood that the air which passes up both the inner and outer passages aforesaid will be heated by the adjacent metal surfaces whereby such air is rendered more efficient both in taking up the vapor and in the combustion thereof. The outer, inclosing ring 6, serves to absorb part of the heat from the flame and to carry down and transmit such heat, by radiation and conduction to the other parts. Any surplus or excess of oil supply that may run over the rim of the oil cup 2 will be partly vaporized in passing down over the flaring lip surface and if any remains, it will fall on the distributor plate or ring 17 and will thereby be spread out and vaporized. The object of the flaring surfaces at 13, 16, is to prevent the oil from falling to the base in large drops and to force the oil to spread out and expose a large surface to the heated air and metal. If the excess of oil is beyond the vaporizing capacity at both the surfaces at 13, 16, the unvaporized portion will fall into the catch-basin or cup 17 where the vaporization will be completed. It may be stated that as regards the oil thus vaporized at 13, 16 and 17, the air passing up through the outer passage 8 serves a similar function in mixing or carbureting to that described in connection with the air passing up through the inner passage 4.

Owing to the differences or variations in the natural draft of different stoves and their chimneys it is desirable to provide means for adjusting the flow of air from the inner passage over the oil to compensate for such difference in draft. To this end I make the proportions of the parts such that the most efficient action is secured with a weak draft and in case the natural draft of the stove to which the burner is to be applied is stronger than such weak draft I apply the ring or washer 21 above referred to, whose thickness should be sufficient to diminish the draft opening proportionately to such increase of draft and maintain the proper condition of suction through the vaporizing chamber or space over the oil draft.

Such change of draft may also be effected by use of different caps with differently shaped external lips so as to vary the draft opening.

The oil deflecting and distributing flange 16, while a desirable feature, is not always essential and may in some cases be omitted,

particularly where the fire-pot or grate space is so low or shallow as to render the use of a low burner desirable. Thus in Fig. V the burner is shown substantially the same in all respects as in Fig. I except that the flange is omitted and the oil cup support 3 is made shorter. The operation will be the same as with the form shown in Fig. I except that the excess or over-flow of oil will run directly into the drip-cup 17.

It will be seen that by either form of the invention a compact burner is provided having an elongated upright body portion 3 forming a tube open at each end thereof and having perforations 5 at different points along the length of the body through the wall thereof, and a passage 27 extending longitudinally through the wall of the body. This body may be formed as a single casting, the annular extensions 15 and 16 being formed integral with the casting, and being adapted to interrupt the flow of the oil as it passes from the feeding means 25 upwardly through the passage 27 and overflows from the annular upper oil cup across the lip 13 and down the sides of the body 3, being received by the cup formed by the extension 17 extending around and integral with the base of the body.

What I claim and desire to secure by Letters-Patent of the United States is:—

1. An oil burner comprising an inner tubular member provided with an annular oil cup having an external lip, for directing air from the cup, and an outer tubular member forming an exterior air passage surrounding said cup and lip, said inner tubular member being provided with an oil distributing and deflecting surface arranged below said lip.
2. An oil burner comprising an oil cup, a tubular support for said cup formed with an interior air passage and with lateral perforations, a heat absorbing and transmitting wall surrounding the tubular support with an intervening air passage, an oil deflecting flange on the tubular support below the oil cup, and means for supplying oil to the oil cup.
3. An oil burner comprising an oil cup, a tubular support therefor formed with an interior passage, a removable deflecting cap over said cup and the interior passage, and a removable ring on the tubular support and between said cap and cup, to regulate the supply of air through the interior passage.
4. An oil burner comprising an elongated upright body forming a tube open at each end thereof having walls perforated at different points along the length thereof and a passage extending longitudinally through the wall of the body; means for feeding oil to said passage at the lower end thereof, there being an oil receiving cup communicating with the top of said passage; a cap at the top of said body, there being pas-

sages through the wall of said body adjacent to said cap and above the oil cup, said oil cup being formed as an annular groove extending around the wall of the body at the top end thereof and positioned to allow the oil to flow from said cup down the sides of the body; an extension formed integral with the wall of said body extending around the outside thereof in position to interrupt the downward flow of the oil from said cup, and an extension extending around the base of said body and forming a cup adapted to receive oil from the first-mentioned extension.

5. An oil burner comprising a substantially tubular body, the upper end of which is recessed to form openings and the wall of which is perforated and the exterior provided with an annular oil-cup between the perforations and the top, an oil receptacle at the bottom, and a distributing surface intermediate the cup and the receptacle; and a cap above the body and the cup.

6. An oil burner comprising a hollow perforated elongated body, the lower end of which is provided with a base and the upper end with an annular oil cup, and the wall upon one side is provided with a longitudinal passage communicating with said cup, a cap on top of the body, a circular wall around and at a distance from said body, there being holes for introducing air to the space between the body and the wall, and means through the base for introducing fuel through said passage to said cup.

7. An oil burner comprising a tubular support having an oil receptacle in its upper end and forming an air passage extending upwardly through said support and interiorly of the oil receptacle, and an oil distributing and deflecting flange extending from the tubular support and below the oil receptacle, said tubular support being provided with lateral openings through its wall above and below said flange.

8. An oil burner for stoves and grates comprising a base adapted to act as a closure for the grate, outer and inner tubular means extending upwardly from said base and forming outer and inner air passages, said inner tubular means being provided with lateral openings extending from the inner to the outer air passage, an oil cup at the top of the inner tubular means and surrounding the inner air passage, and a deflector above said air passages, said inner tubular means having an upward projection supporting said deflector and provided with openings leading from the inner air passage to the space over the oil passage.

9. An oil burner for stoves and grates comprising a base adapted to act as a closure for the grate, outer and inner tubular means extending upwardly from said base and forming outer and inner air passages, an oil cup at the top of the inner tubular

means and surrounding the inner air passage, and an external flange on the inner tubular means below the oil cup.

5 10. An oil burner for stoves and grates comprising a base adapted to act as a closure for the grate, outer and inner tubular means extending upwardly from said base and forming outer and inner air passages, an oil cup at the top of the inner tubular means and
10 surrounding the inner air passage, and an external flange on the inner tubular means below the oil cup, said inner tubular means being provided with lateral openings extending from the inner to the outer air passage.
15 above said flange.

11. An oil burner for stoves and grates comprising a base adapted to act as a closure for the grate, outer and inner tubular means extending upwardly from said base and
20 forming outer and inner air passages, an oil cup at the top of the tubular support and surrounding the inner air passage, and an external flange on the inner tubular means below the oil cup, said inner tubular means

being provided with lateral openings extending from the inner to the outer air passage below said flange. 25

12. An oil burner for stoves and grates comprising a base adapted to act as a closure for the grate, outer and inner tubular means
30 extending upwardly from said base and forming outer and inner air passages, an oil cup at the top of the inner tubular means and surrounding the inner air passage, and an external flange on the inner tubular
35 means below the oil cup, said inner tubular means being provided with lateral openings extending from the inner to the outer air passage above and below said flange.

In testimony whereof, I have signed my
40 name to this specification in the presence of two subscribing witnesses, at Los Angeles, in the county of Los Angeles and State of California, this 11th day of February, 1903.

WILLIAM NEWTON BEST.

Witnesses:

ARTHUR P. KNIGHT,
JULIA TOWNSEND.