



US00D697104S

(12) **United States Design Patent**
Dye et al.

(10) **Patent No.:** **US D697,104 S**
(45) **Date of Patent:** **** Jan. 7, 2014**

(54) **MANUFACTURING ROBOT**

(71) Applicants: **Noelle Dye**, Charlestown, MA (US);
Peter Swai, Weymouth, MA (US); **Ben Berkowitz**, Sharon, MA (US); **Jonathan Bond**, Newton, MA (US); **Michael Lewis**, Burlington, MA (US); **Andrew Wallace**, Needham, MA (US); **Kristin Size**, Waltham, MA (US); **Michael Caine**, Needham, MA (US); **Elizabeth Goodrich**, Roslindale, MA (US)

(72) Inventors: **Noelle Dye**, Charlestown, MA (US);
Peter Swai, Weymouth, MA (US); **Ben Berkowitz**, Sharon, MA (US); **Jonathan Bond**, Newton, MA (US); **Michael Lewis**, Burlington, MA (US); **Andrew Wallace**, Needham, MA (US); **Kristin Size**, Waltham, MA (US); **Michael Caine**, Needham, MA (US); **Elizabeth Goodrich**, Roslindale, MA (US)

(73) Assignee: **Rethink Robotics, Inc.**, Boston, MA (US)

(**) Term: **14 Years**

(21) Appl. No.: **29/449,905**

(22) Filed: **Mar. 15, 2013**

(51) **LOC (10) Cl.** **15-99**

(52) **U.S. Cl.**
USPC **D15/199**

(58) **Field of Classification Search**
USPC D6/396, 397; D15/199; D20/21, 31, 99;
D21/59, 578-583, 593, 621, 622;
D24/176; D25/16; D32/21; D34/35;
74/490.01, 490.02, 490.03, 490.05;
180/8.6; 198/367, 370.1, 370.04, 772,

198/771, 782, 866, 890, 890.1; 219/124.34,
219/639; 318/560, 568.12, 568.2;
364/424.02; 414/744.1, 935, 936, 937,
414/938, 940; 446/268-274, 280, 285,
446/289-292, 294, 297-303, 353-355,
446/376-384

See application file for complete search history.

(56) **References Cited**

U.S. PATENT DOCUMENTS

D572,739	S	*	7/2008	Jennings et al.	D15/199
D622,747	S	*	8/2010	Kobayashi et al.	D15/199
D622,786	S	*	8/2010	Lee	D21/578
D646,703	S	*	10/2011	Wong	D15/199
D655,324	S	*	3/2012	Wong	D15/199
D681,134	S	*	4/2013	Lee	D21/578

* cited by examiner

Primary Examiner — Patricia Palasik

(74) *Attorney, Agent, or Firm* — Bingham McCutchen LLP

(57) **CLAIM**

The ornamental design for a manufacturing robot, substantially as shown.

DESCRIPTION

FIG. 1 is a perspective view of a manufacturing robot incorporating the design;
FIG. 2 is a front view thereof;
FIG. 3 is a back view thereof;
FIG. 4 is a right-side view thereof;
FIG. 5 is a left-side view thereof;
FIG. 6 is a top view thereof; and,
FIG. 7 is a bottom view thereof.
The broken lines in the drawings depict unclaimed environmental subject matter.

1 Claim, 7 Drawing Sheets

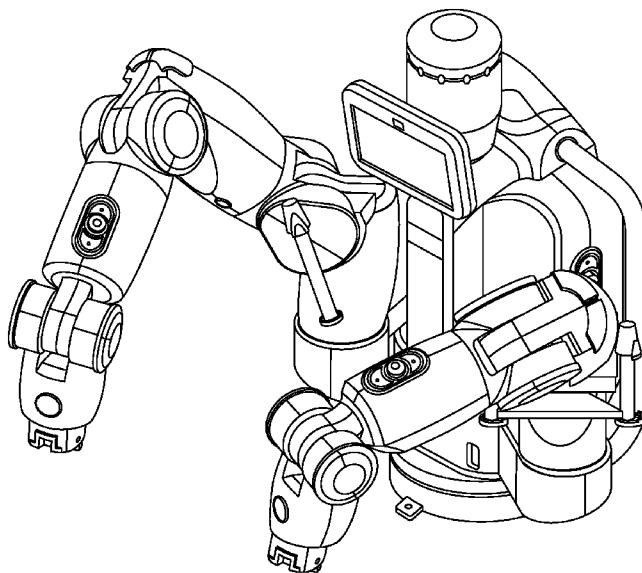

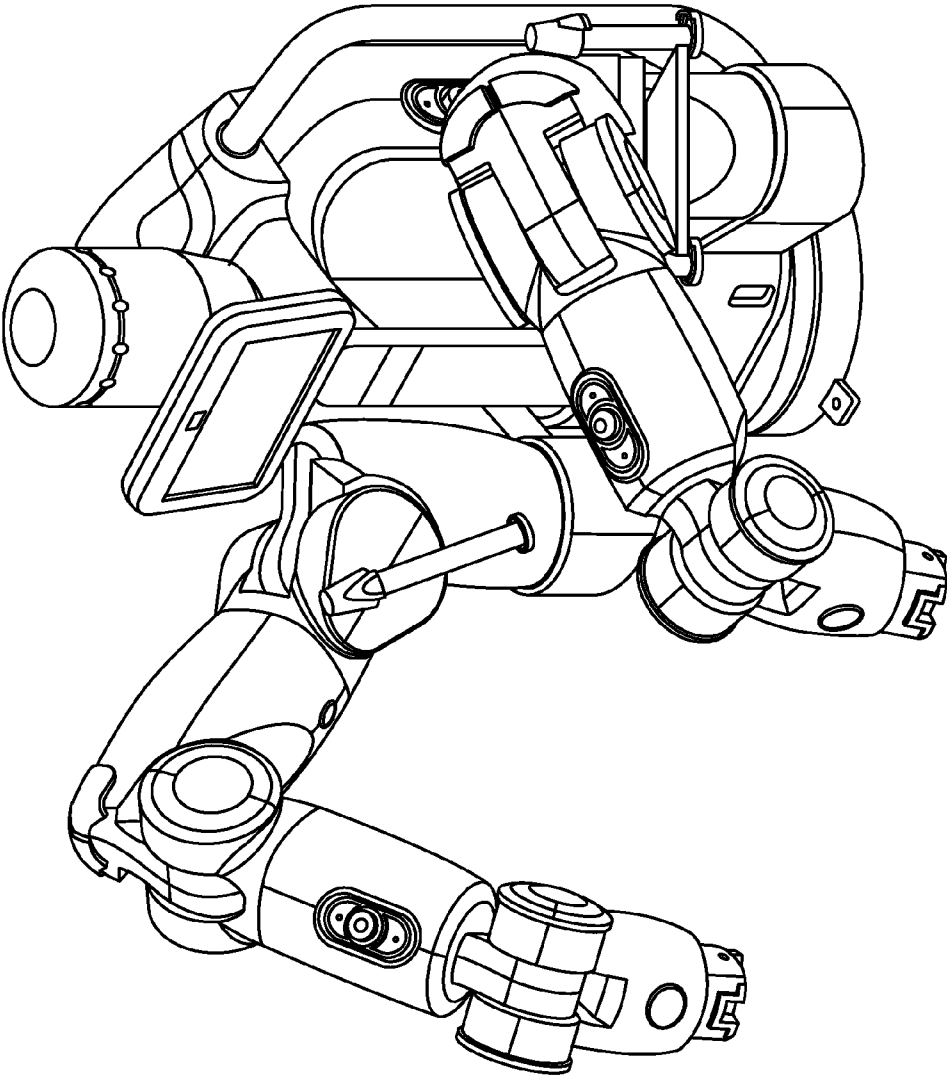

FIG. 1

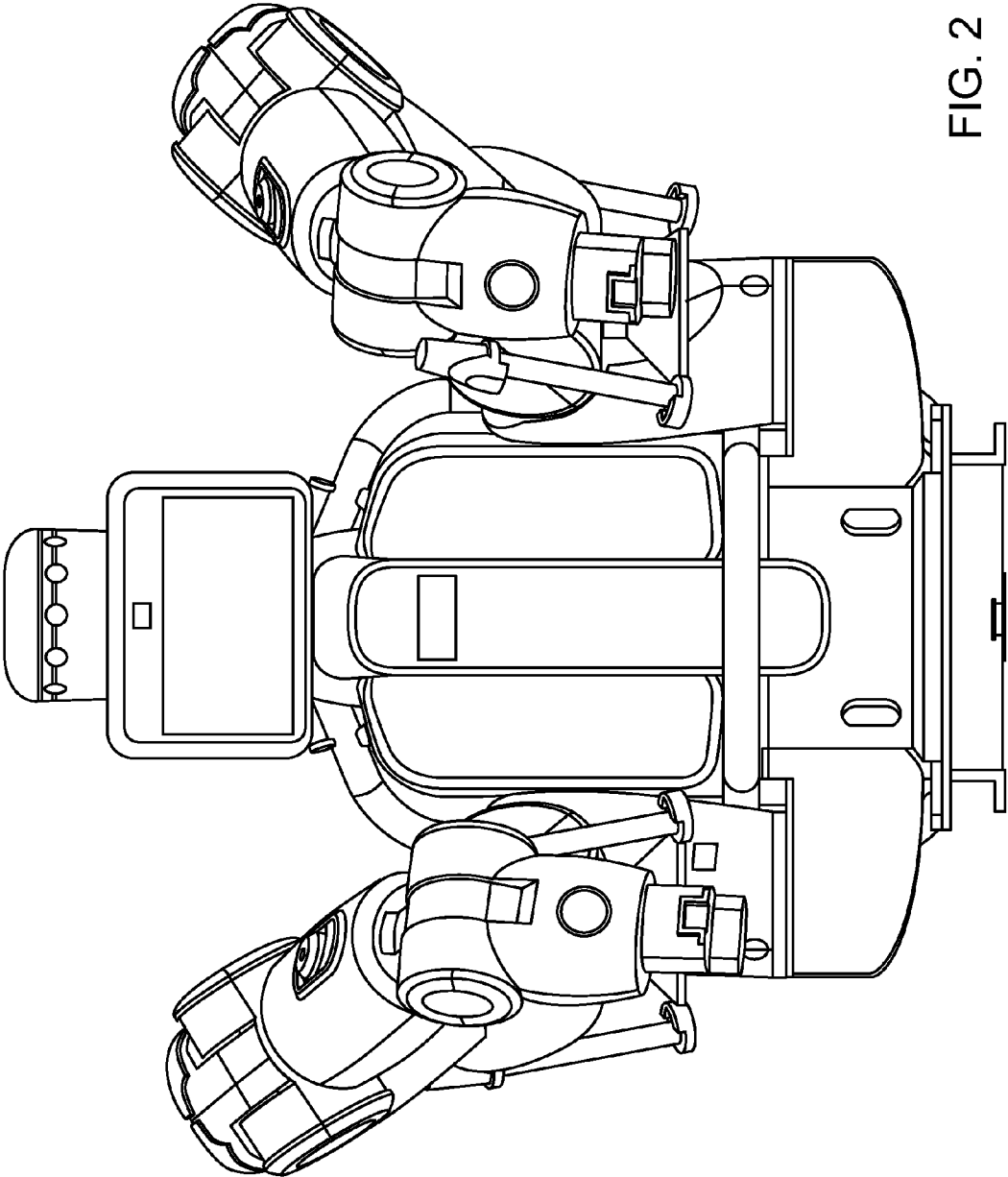

FIG. 2

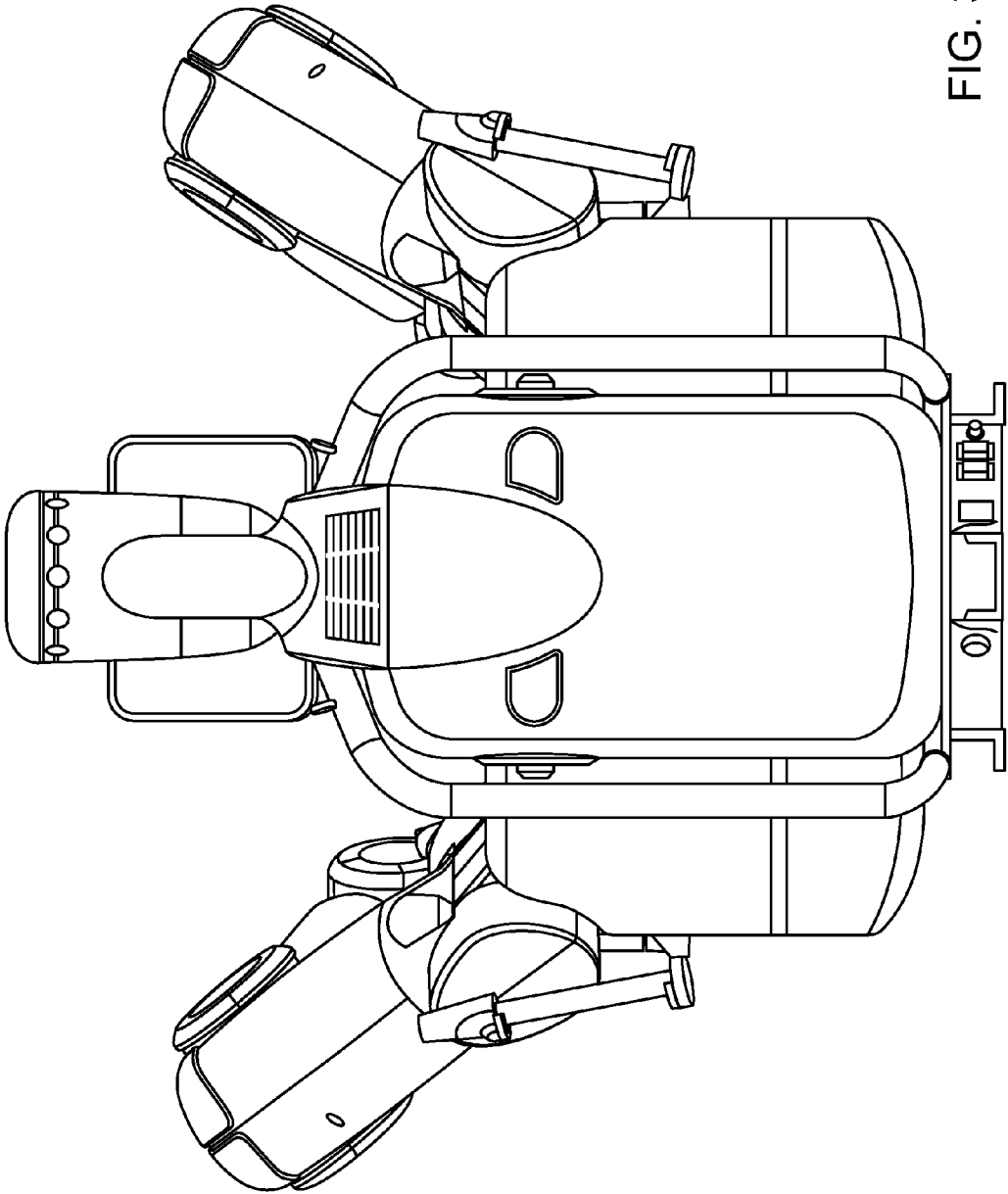

FIG. 3

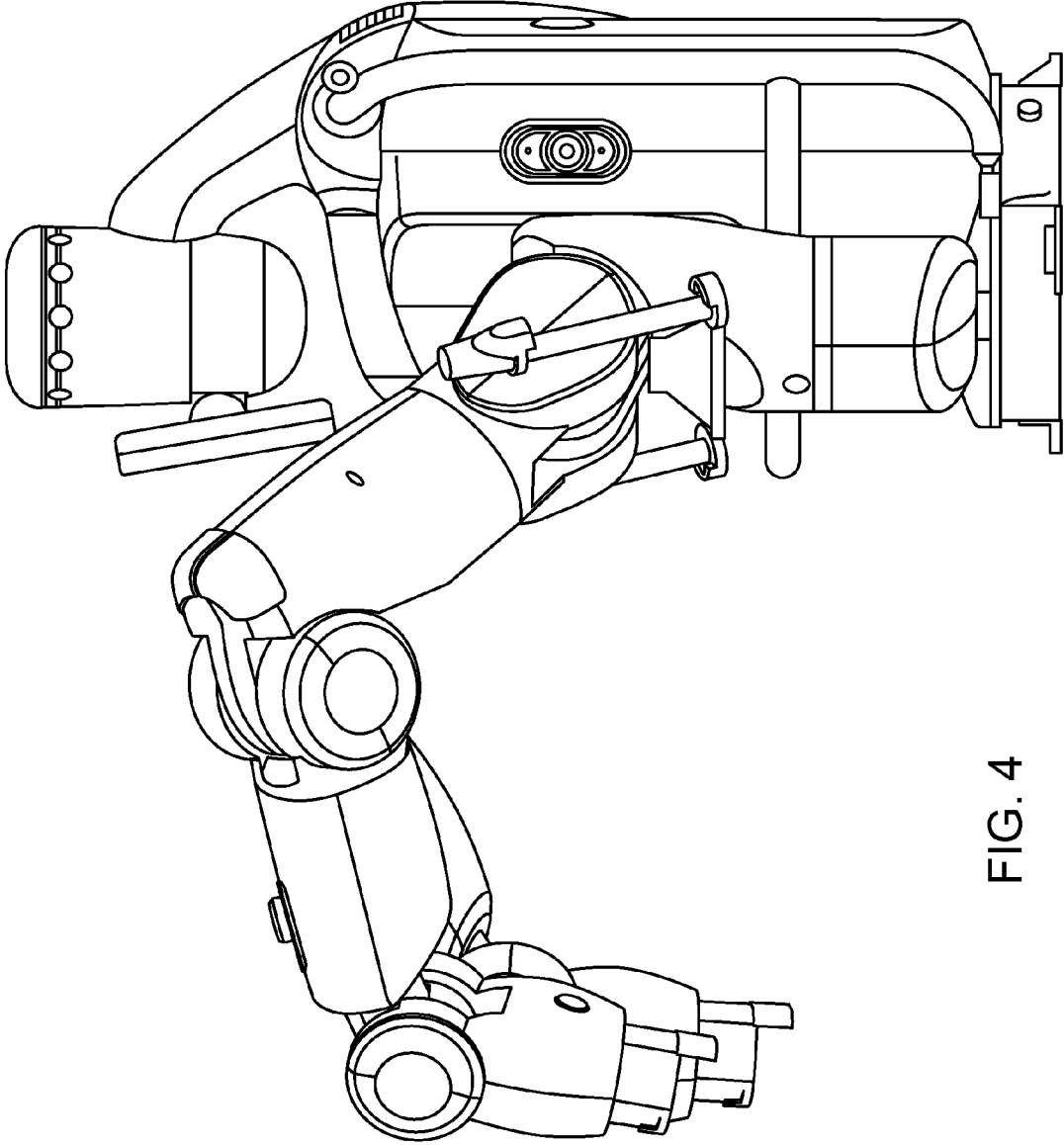

FIG. 4

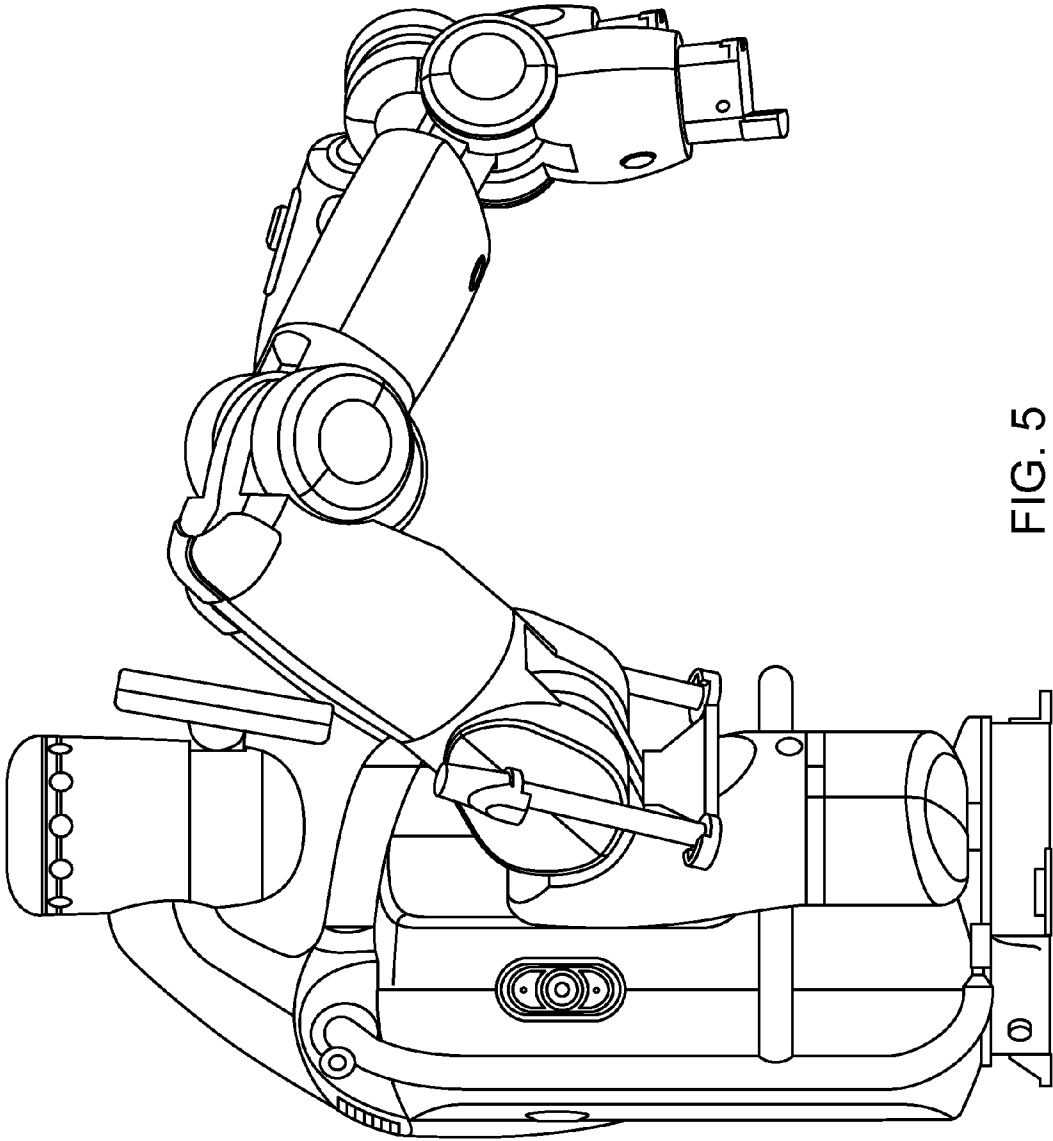

FIG. 5

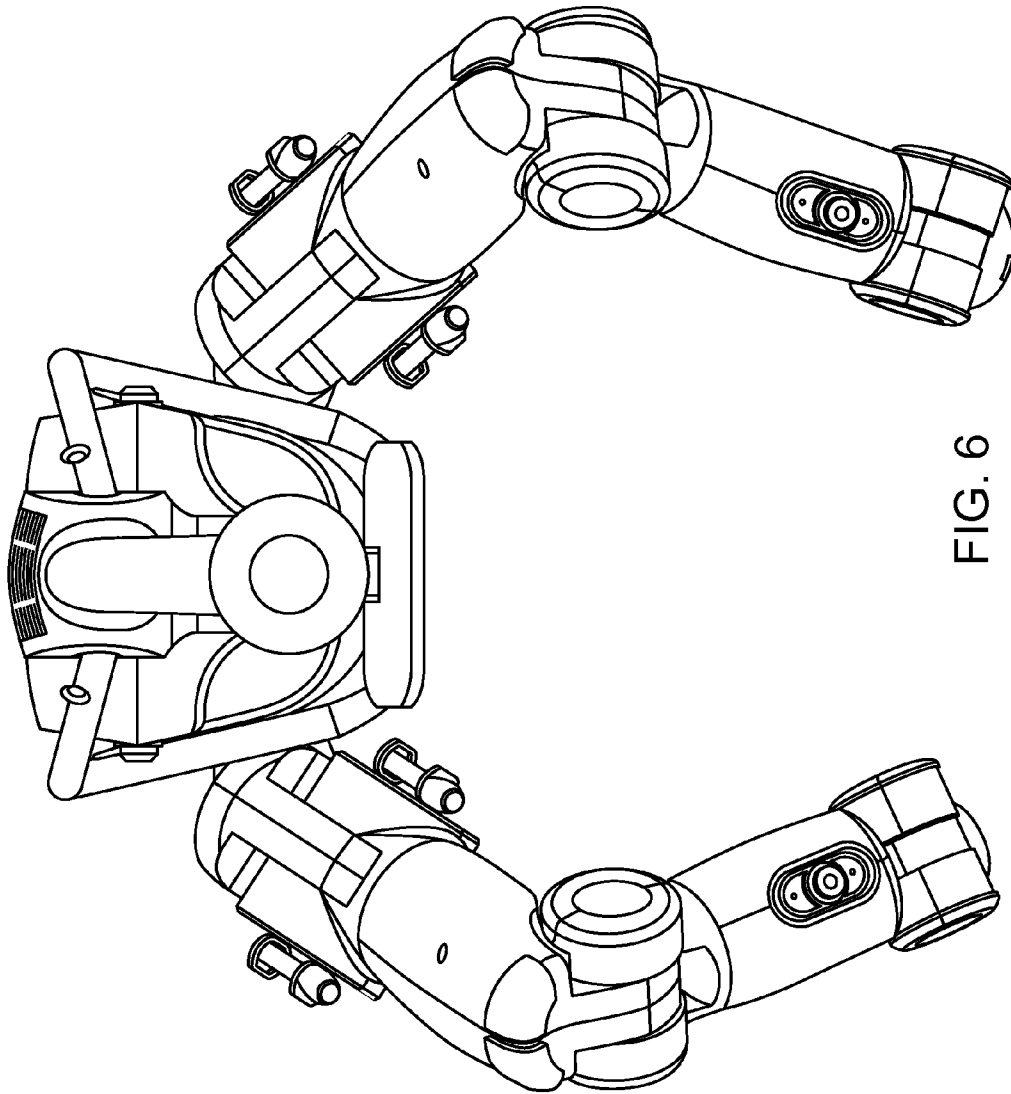

FIG. 6

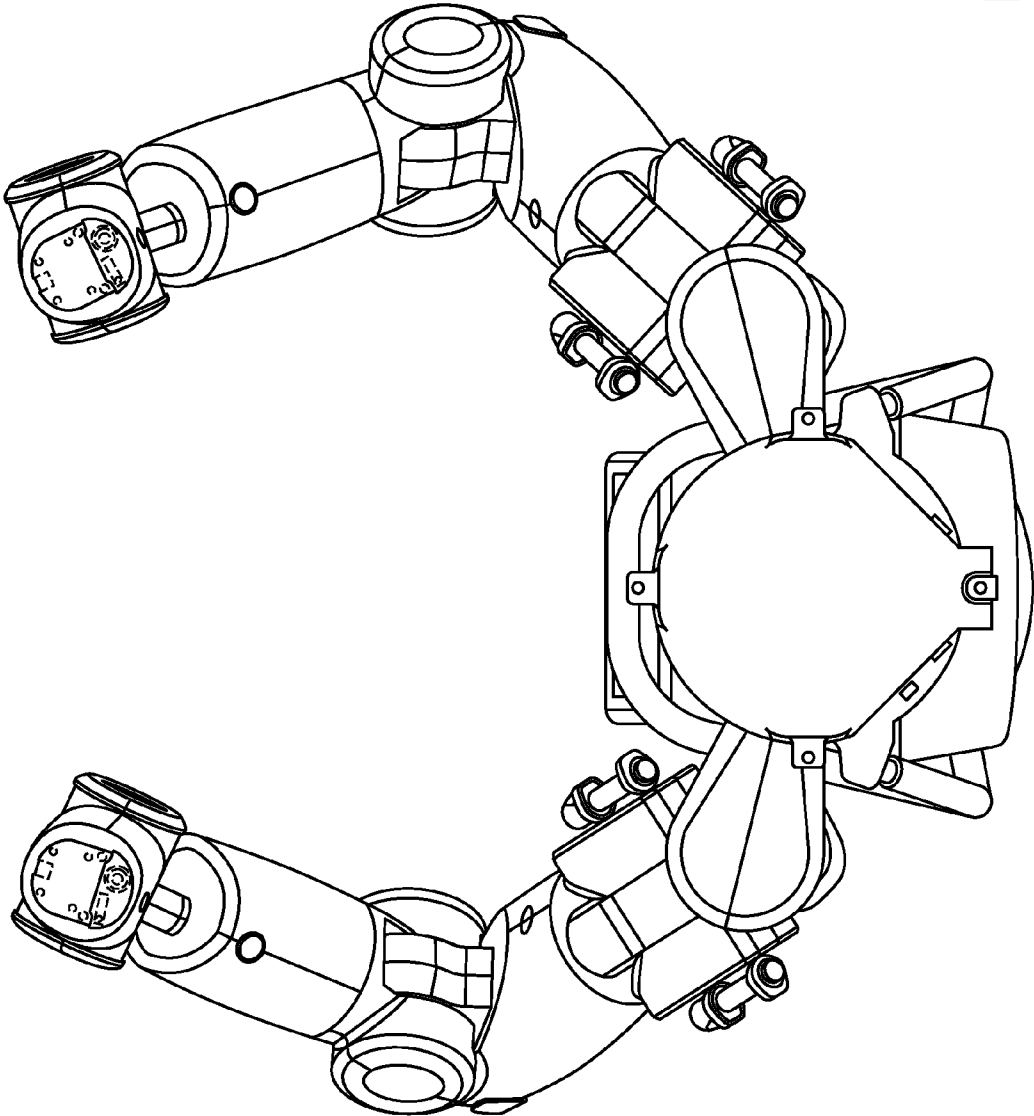

FIG. 7