

D. F. EBBERT.
 LOCK FOR AUTOMOBILE HOODS.
 APPLICATION FILED APR. 6, 1911.

1,004,154.

Patented Sept. 26, 1911.

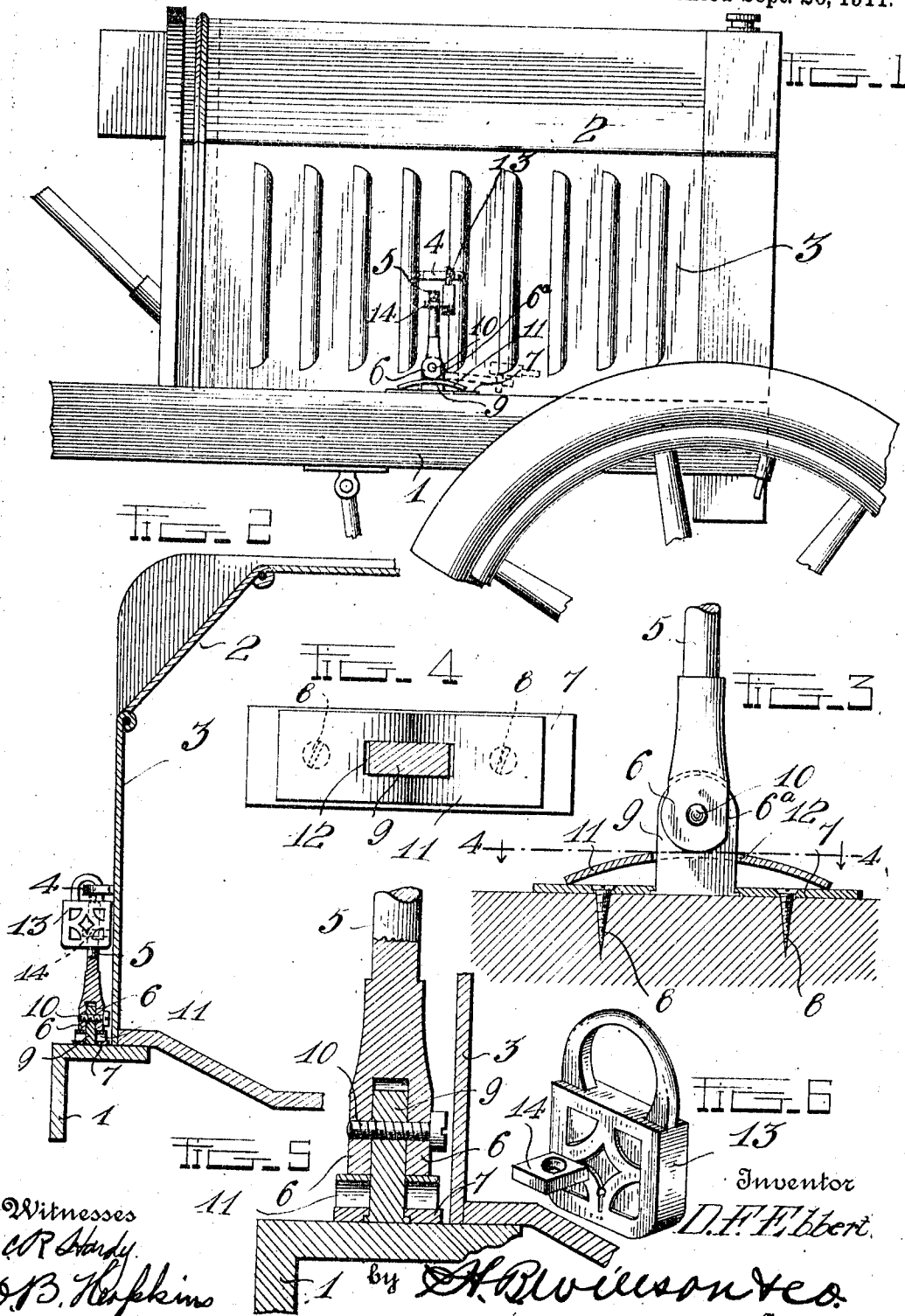

Witnesses
 C. R. Hardy
 O. B. Hopkins

Inventor
 D. F. Ebbert

by *A. B. Wilson & Co.*
 Attorneys

UNITED STATES PATENT OFFICE.

DANIEL F. EBBERT, OF WHEELING, WEST VIRGINIA.

LOCK FOR AUTOMOBILE-HOODS.

1,004,154.

Specification of Letters Patent. Patented Sept. 26, 1911.

Application filed April 6, 1911. Serial No: 619,310.

To all whom it may concern:

Be it known that I, DANIEL F. EBBERT, a citizen of the United States, residing at Wheeling, in the county of Ohio and State of West Virginia, have invented certain new and useful Improvements in Locks for Automobile-Hoods; and I do declare the following to be a full, clear, and exact description of the invention, such as will enable others skilled in the art to which it appertains to make and use the same.

This invention relates to improvements in locks for automobile hoods.

One object of the invention is to provide a lock of this character adapted to be applied to the frame of the vehicle and to be engaged with the handle of the hood whereby the latter is locked in closed position.

A further object is to provide a locking device of this character which may be adjusted to engage handle when arranged in various positions and constructed in different styles.

With these and other objects in view, the invention consists of certain novel features of construction, combination and arrangement of parts as will be more fully described and particularly pointed out in the appended claims.

In the accompanying drawings: Figure 1 is a side view of the front end of an automobile showing the application of the invention to the hood; Fig. 2 is a detail vertical sectional view through one side of the hood and the adjacent parts of the machine showing the lock arranged thereon; Fig. 3 is a central vertical sectional view through the attaching plate and lower end of the pivoted fastening arm; Fig. 4 is a horizontal sectional view on the line 4-4 of Fig. 3; Fig. 5 is an enlarged vertical cross section of a portion of the frame and hood and the lower end of the pivoted arm and its attaching mechanism; Fig. 6 is a detail perspective view of the lock and the nut arranged thereon for adjustably connecting the same to the pivoted arm.

Referring more particularly to the drawings 1 denotes the front end of an automobile supporting frame, and 2 denotes the hood which covers the motor. The hood 2 is here shown as having the usual form of hingedly connected side plates 3 which swing downwardly into engagement with the frame 1 when in a closed position. To the lower member of the side plates 3 is se-

cured the usual or any suitable form of handle 4 whereby said side members are readily swung upwardly and downwardly to open and closed position.

In order to lock the side members of the hood down in a closed position I provide a suitable locking mechanism comprising a pivoted arm 5 the lower end of which is bifurcated or provided with parallel apertured bearing lugs 6, while the opposite end of the same is threaded. Secured to the side rails of the frame 1 of the machine below the handle 4 of the hood is an arm attaching plate 7, said plate being fastened to the frame or rails by screws or similar devices 8. Formed on or rigidly secured to the plate 7 is a central upwardly projecting apertured pivot lug 9 with which is engaged the apertured lug 6 of the lower end of the arm 5. The apertured lugs 6 are pivotally connected to the lug 9 by a pivot screw 10 which is inserted through the apertures in the lugs from the inner side of the arm or adjacent to the side of the hood whereby when the hood is closed the head of the screw will be covered and protected against removal.

In order to prevent the removal of the screws 8 of the attaching plates 7, I provide a flat spring metal covering plate 11 having therein a centrally disposed slot 12 through which the lug 9 projects when the plate 11 is arranged in position on the attaching plate as shown in Figs. 3 and 4 of the drawings. The spring plate 11 when thus arranged bows or is curved upwardly and engages the lower edges of the lug 6 on the arm and thereby holds these parts against rattling.

Arranged on the threaded upper end of the arm 5 is a lock 13 said lock being provided on one side with an offset lug or nut 14 having a threaded engagement with the upper end of the arm whereby the lock may be adjusted in position to engage the bail thereof with the handle 4 of the hood thereby securely locking the latter in closed position. Any form of combination or key operated lock or one which cannot be unlocked by unauthorized persons is employed in connection with the arm 5 for locking the hood in the manner described. By hingedly connecting the arm to the frame of the machine in the manner described, said arm may be swung downwardly when unlocked from the handle thus permitting the opening and clos-

ing of the hood without danger of striking the hand or the nuts on the other end of the arm when the latter are rigidly secured to the frame. It will be noted that one side of each of the bearing lugs 6 of the arm 5 is cut off to form flat surfaces 6^a which when the arm is swung down to an inoperative position as shown in dotted lines in Fig. 1 will engage the spring plate 11, said plate thus firmly holding the arm down in inoperative position. By thus locking the hood over the engine, the latter, the carbureter or any of the wiring mechanism or other parts inclosed by the hood will be securely protected from being tampered with or molested by an unauthorized person thus obviating the inconvenience and annoyance which frequently occurs by the interference, maliciously or otherwise with the working parts of an automobile inclosed in the hood when the machine is left unprotected.

From the foregoing description taken in connection with the accompanying drawings, the construction and operation of the invention will be readily understood without requiring a more extended explanation.

Various changes in the form, proportion and the minor details of construction may be resorted to without departing from the principle or sacrificing any of the advantages of the invention as defined in the appended claims.

Having thus described my invention, what I claim is:

35 1. A lock for automobile hoods comprising an arm having on its lower end parallel apertured attaching lugs, an attaching plate adapted to be secured to the frame of the machine, a pivot lug arranged on said plate and adapted to receive the apertured lugs on said arm, a pivot screw arranged through said lugs whereby the arm is pivotally connected to said plate, means to prevent the removal of the attaching plate, and arm fastening screws, a lock adapted to be engaged with the handle of the hood and a threaded nut secured to said lock and adapted to be screwed onto said arm whereby the lock is adjustably connected to the arm to engage said handle and the hood thereby locked in a closed position.

50 2. A lock for automobile hoods compris-

ing a pivoted arm threaded at one end and having its opposite end bifurcated, an attaching plate, attaching devices to secure said plate to the frame of the machine, a pivot lug arranged on said plate and adapted to receive the bifurcated lower end of the arm, a pivot screw arranged through said bifurcated end of the arm and said pivot lug, said screw having its head disposed adjacent to the side of the hood whereby access to the screw head is prevented when the hood is closed, a spring guard plate arranged on said attaching plate and over the attaching devices therein whereby the latter are protected from removal said spring guard plate having a yielding engagement with the bifurcated lower end of the bolt whereby the same is prevented from rattling, a lock adapted to be engaged with the handle of the hood and a nut secured to said lock and adapted to be screwed onto the threaded outer end of the arm whereby said lock is adjustably connected to the latter in position to be engaged with the handle of the hood.

3. A lock for automobile hoods comprising a pivoted arm threaded on one end and having on its opposite end apertured attaching lugs, said lugs having on one edge flattened surfaces, an attaching plate secured to the frame of the machine, a pivot lug formed on said plate and adapted to receive the apertured lugs on said arm, and means to pivotally connect the lugs of the arm with the lug on said attaching plate, a spring guard plate arranged over said attaching plate, said guard plate having a yielding engagement with the pivot lugs on the lower end of said arm whereby the latter is held against rattling when in an operative position and whereby when said arm is swung down to an inoperative position the flat surfaces of its connecting lugs will engage said spring guard plate and thus hold and lock the arm in an inoperative position.

In testimony whereof I have hereunto set my hand in presence of two subscribing witnesses.

DANIEL F. EBBERT.

Witnesses:

H. A. SEABRIGHT,
LESTER COWAN.