

(19) **DANMARK**

(10) **DK/EP 4100649 T3**



(12)

## Oversættelse af europæisk patentskrift

Patent- og  
Varemærkestyrelsen

- 
- (51) Int.Cl.: **F 04 B 43/02 (2006.01)** **B 01 F 25/00 (2022.01)** **B 01 F 25/60 (2022.01)**  
**F 04 B 23/02 (2006.01)** **F 04 B 43/04 (2006.01)** **F 04 B 49/22 (2006.01)**
- (45) Oversættelsen bekendtgjort den: **2025-01-20**
- (80) Dato for Den Europæiske Patentmyndigheds bekendtgørelse om meddelelse af patentet: **2024-12-25**
- (86) Europæisk ansøgning nr.: **21751085.8**
- (86) Europæisk indleveringsdag: **2021-01-29**
- (87) Den europæiske ansøgnings publiceringsdag: **2022-12-14**
- (86) International ansøgning nr.: **US2021015917**
- (87) Internationalt publikationsnr.: **WO2021158448**
- (30) Prioritet: **2020-02-04 US 202062970103 P**
- (84) Designerede stater: **AL AT BE BG CH CY CZ DE DK EE ES FI FR GB GR HR HU IE IS IT LI LT LU LV MC MK MT NL NO PL PT RO RS SE SI SK SM TR**
- (73) Patenthaver: **Alphinity USA, Inc., 1771 South Sutro Terrace, Carson City, NV 89706, USA**
- (72) Opfinder: **GAGNE, Michael C., 1771 S. Sutro Terrace, Carson City, Nevada 89706, USA**
- (74) Fuldmægtig i Danmark: **IPSILON BENELUX S.A., 76, rue de Merl, L-2146 Luxembourg, , Luxembourg**
- (54) Benævnelse: **PUMPE/BLANDERANORDNING**
- (56) Fremdragne publikationer:  
**WO-A1-2018/144391**  
**CN-A- 108 661 892**  
**US-A- 4 153 391**  
**US-A- 4 486 151**  
**US-A- 5 476 367**  
**US-A- 6 007 314**  
**US-A1- 2013 034 452**  
**US-A1- 2017 135 532**



**Description****Technical Field**

**[0001]** The field of the invention generally relates to fluid-based systems and processes used in the manufacture, production, or capture of products. More specifically, the invention pertains to pumps and mixers used in bioprocess, pharmaceutical, biological, gene therapy applications or other hygienic process industries.

**Background**

**[0002]** Many commercial products are produced using chemical as well as biological processes. Pharmaceuticals, for example, are produced in commercial quantities using scaled-up reactors and other equipment. So-called biologics are drugs or other compounds that are produced or isolated from living entities such as cells or tissue. Biologics can be composed of proteins, nucleic acids, biomolecules, or complex combinations of these substances. They may even include living entities such as cells. For example, in order to produce biologics on a commercial scale, sophisticated and expensive equipment is needed. In both pharmaceutical and biologics, for example, various processes need to occur before the final product is obtained. In the case of biologics, mammalian cells may be grown in a container such as a growth chamber, reactor, bag or the like and nutrients may need to be carefully modulated into the unit holding the cells.

**[0003]** Importantly, biologic products produced by living cells or other organisms may need to be grown, filtered, extracted, concentrated, and ultimately collected from the growth container. Often reagents are loaded in growth containers and combined with other fluid stream(s) or inputs and require mixing. For example, buffer solutions are often added and mixed with other feed stream(s) during the manufacturing process. Waste products produced by cells typically have to be removed on a controlled basis from the growth container. Typically, desired biologic products produced by cells and/or waste products are pumped out of the container where growth occurs using a separate pumping device that is located downstream with respect container containing the cells. This pumped fluid that is removed from the growth chamber is typically subject to downstream processing such as separation or filtration.

**[0004]** As noted above, pumps are needed to move fluid and the contents thereof from one unit operation to another. In addition to actually moving fluid via pumps, mixing is often needed during one or more of these operations. For example, concentrated buffer solutions may be combined with a larger volume of water to make desired buffer concentrations that are used in one or more downstream processes. Typically, this happens in vessels or containers that contain a mixer therein.

**[0005]** US 2017/0135532 A1 discloses a diaphragm pump for dispensing foam by mixing air with soap, for

sanitary purposes.

**[0006]** CN 108661892 A discloses a diaphragm gas-liquid mixing pump and a foam maker, for sanitary purposes.

5 **[0007]** WO 2018/144391 A1 discloses a bioprocess vessel including a flexible bag or substantially rigid container that defines an interior volume and having a bottom surface, the bottom surface being open or containing an aperture therein for the passage of fluid. A diaphragm pump is secured to the bottom surface of the flexible bag or substantially rigid container. The diaphragm pump comprises an inlet located at a top of the pump, the inlet configured to be secured to a bottom of the vessel; a plurality of chambers disposed in the pump and fluidically connected to the inlet by respective check-valves; an outlet fluidically connected to the chambers, a diaphragm disposed in each of the plurality of chambers, the moveable diaphragms interfacing with a respective actuating element driven by a wobble plate operatively coupled to a motor or drive unit. Improvements are, however, desirable.

10  
15  
20  
25  
30  
35  
40 **[0008]** Existing pumps are known that are used in biopharmaceutical operations. For example, the Quattroflow™ four-piston diaphragm pump is known that does not use any wetted rotating parts but instead uses four separately actuated diaphragms that are used to pump fluid. A typical problem with pumps is that they are generally connected to a vessel through various conduits. When incorporating pumps into fluid pathways, there is a need to design such systems to avoid problems caused by cavitation, vacuum or pulsed flow condition. Cavitation and non-steady flow conditions tend to lyse the delicate mammalian cells that are used in these manufacturing processes. Unfortunately, when pumps are placed downstream from containers or vessels, this inevitably tends to produce cavitation, vacuum, and problematic flow conditions that tend to kill or disrupt cells or results in low flow conditions. This causes pulsation at low flow rates and does not solve the main problem of getting fluid into the pump efficiently. There thus is a need for improved pump and mixer devices.

**Summary**

45 **[0009]** The invention is directed to a pump/mixer device, according to claim 1, including a main inlet located at the top or upper region of the pump/mixer, the main inlet configured to be secured to or integrated into a bottom of a vessel or container. An outer chamber is disposed in the pump/mixer and is fluidically connected to the main inlet. A plurality of lower chambers are disposed in the pump/mixer beneath the outer chamber and fluidically connected to the outer chamber by respective check valves interposed between the outer chamber and the plurality of lower chambers. A central chamber is disposed in the pump/mixer, wherein the central chamber is fluidically connected to the plurality of lower chambers with respective check valves interposed between the

central chamber and the plurality of lower chambers. The pump/mixer has at least one outlet. The pump/mixer has one or more additional inlets fluidically coupled to the central chamber via respective inlet check valve(s). A moveable diaphragm is disposed in each of the plurality of lower chambers, the moveable diaphragms interfacing with a respective actuating element driven by a wobble plate or nutating disk operatively coupled to a motor or drive unit, wherein actuation causes each of the moveable diaphragms to move in opposing direction (e.g., up and down). This movement pumps fluid through the pump/mixer.

**[0010]** Further developments of the invention are according to dependent claims 2-13.

**[0011]** The invention is also directed to a method of operating the pump/mixer of the invention, according to claim 14, including driving the motor or drive unit to actuate the wobble or nutating plate; inputting a first fluid from the vessel or container into the main inlet pump/mixer; inputting second or additional fluid(s) into the pump/mixer via the one or more additional inlets; mixing the first fluid and the second or additional fluid(s) in the central chamber of the pump/mixer; and outputting the mixed fluid via the at least one outlet.

**[0012]** Further developments of the invention are according to dependent claims 15-17.

### Brief Description of the Drawings

#### **[0013]**

FIG. 1 illustrates a pump according to one embodiment. The pump includes a plurality of outlets. One or more of the outlets may be substituted with inlets (and inlet check valves) to create a pump/mixer as explained herein.

FIG. 2 illustrates an exploded view of a pump of the type illustrated in FIG. 1.

FIG. 3 illustrates a cross-sectional view of the pump embodiment of FIG. 1. The direction of fluid flow from the inlet to the outlet is illustrated by arrow A.

FIG. 4 is a cross-section illustrating the central housing of the pump of FIG. 1.

FIG. 5 is another cross-section taken along the central housing of the pump of FIG. 1.

FIG. 6A illustrates a top-down view of a pump/mixer device according to one embodiment.

FIG. 6B illustrates a top-down cross-section of the pump/mixer device of FIG. 6A that shows the how the wobble or nutating plate interfaces with the actuating ring and actuating elements to drive the pump/mixer. While the pump/mixer is shown in FIGS. 6A and 6B, the pumping operation is the same with the pump of FIG. 1.

FIG. 7 illustrates a pump/mixer according to one embodiment. The pump/mixer includes a plurality of inlets (5) and a single outlet.

FIG. 8 illustrates an exploded view of the pump/mixer

of FIG. 7.

FIG. 9 illustrates a cross-sectional view of the pump/mixer of FIG. 7. The direction of fluid flow from the inlets (top and side) to the outlet is illustrated by arrows.

FIG. 10 is a cross-section showing the central housing of the pump/mixer of FIG. 7.

FIG. 11 is another cross-section taken of the central housing of the pump/mixer of FIG. 7.

FIG. 12 illustrates an additional embodiment of a pump/mixer that includes a plurality of outlets and a plurality of inlets. In this embodiment, eleven (11) inlets are located on the upper housing and the central housing.

FIG. 13A illustrates an embodiment of a pump (e.g., a pump of the embodiment of FIG. 1) being secured to a container or vessel.

FIG. 13B illustrates an embodiment of a pump/mixer (e.g., a pump/mixer of the embodiment of FIG. 7) being secured to a container or vessel.

FIG. 14 illustrates a central pump/mixer secured to a vessel or container along with conduits or tubing that connect inlets on the centrally located pump/mixer to two different pump(s) and/or pump/mixer(s) coupled to respective vessels or containers.

FIG. 15 illustrates an exemplary dilution operation that uses a plurality of pump/mixers.

FIG. 16A illustrates a perspective view of an embodiment of pump/mixers used in a bioreactor application. Two bioreactor vessels or containers are illustrated, each with their own dedicated pump/mixer device.

FIG. 16B is a side view of the bioreactor system of FIG. 16A.

FIG. 17A illustrates a perspective view of an embodiment of a pump/mixer used in another bioreactor application. A single bioreactor vessel or container (e.g., flexible bag) is illustrated along with the coupled pump/mixer device. The flexible bag is held within a frame (with one wall omitted for clarity).

FIG. 17B is a front view of the bioreactor system of FIG. 17A.

FIG. 17C is a side view of the bioreactor system of FIG. 17A.

### Detailed Description of the Illustrated Embodiments

**[0014]** FIG. 1 illustrates one embodiment of a pump 10 or a pump/mixer 70. Whether the device is a pump 10 or a pump/mixer 70 depends on whether there are additional inlets 72, as explained herein, integrated into the device beyond the main inlet 12. The pump 10 or pump/mixer 70 includes a main inlet 12 that is located on the top or upper portion of the pump 10 as seen in FIG. 1. In this way, the main inlet 12 is at least partially gravity fed from the top as explained herein. The main inlet 12 may include a flanged end 14 (best seen in FIG. 3) that is cou-

pled to the bottom of a vessel or container 100 as seen in FIGS. 13A, 13B, 14, 16B, 17B, 17C via a port or coupler 101 using a sanitary clamp 104. The port or coupler 101 may, in some embodiments, be integrated into the vessel or container 100. In other embodiments, the pump 10 or pump/mixer 70 may be directly integrated in or bonded to the vessel or container 100. For example, the pump 10 or pump/mixer 70 may be welded to or thermally/chemically bonded to or even integrated into the vessel or container 100. Regardless on the manner in which the pump 10 or pump/mixer 70 is connected to the vessel or container 100 the main inlet 12 is in fluid communication with the interior of the vessel or container 100.

**[0015]** The vessel or container 100 may include both rigid vessels/containers and flexible vessels/containers (e.g., bags). For example, the vessel or container 100 may take the form of a tub, vat, barrel, bottle, tank (e.g., buffer tank), reactor (e.g., bioreactor), flask, or other container suitable for holding fluids, liquids, or materials with fluid-like properties. The vessel or container 100 may be made of any number of materials including metals, polymers, glass, and the like. In one preferred embodiment, the vessel or container 100 is formed from a polymer or resin material and is made as a single-use device. Likewise, one or more portions of the pump 10 or pump/mixer 70 that is directly or indirectly secured to the fluid vessel or container 100 may also be made from a polymer or resin material which facilitates integration or bonding of the pump 10 to the vessel or container 100. In some embodiments, both the pump 10 (or pump/mixer 70) and vessel or container 100 are made from same material. In other embodiments, the pump 10 (or pump/mixer 70) and vessel or container 100 are made from different materials.

**[0016]** The vessel or container 100 may also be flexible such as a bag. The flexible vessel or container 100 (e.g., bag) is typically made from polymer or resin material(s) and may have any number of shapes and sizes. The flexible bag may be formed from multiple layers. The bag includes a pump 10 or pump/mixer 70 that is directly or indirectly secured to a bottom surface of the bag. The vessel or container 100 and attached or integrated pump 10 or pump/mixer 70 may be carried in a trolley, dolly, cradle, cart, holder, or other support container to hold the bag and pump 10 or pump/mixer 70 in the proper orientation. In some embodiments, both the pump 10 or pump/mixer 70 and bag are made from the same material. In other embodiments, the pump 10 or pump/mixer 70 and bag are made from different materials.

**[0017]** As noted above, the pump 10 or pump/mixer 70 may be secured to the bottom of the vessel or container 100 at port or coupler 101. For example, a sanitary clamp 104 (e.g., Tri-clamp) and O-ring 106 such as that illustrated in FIG. 8 may be used to clamp the flanged end 14 of the pump 10 to another flanged end of the port or coupler 101 located on the bottom of the vessel or container 100. In other embodiments, the main inlet 12 (or upper housing 22) is directly integrated in or manufac-

ured in the vessel or container 100. For example, the main inlet 12 may be formed as an aperture or opening located in the bottom of the vessel or container 100. The main inlet 12 is, in one embodiment, a circular shaped inlet that has a diameter of about one inch or more (although various dimensions may be used). For example, the main inlet 12 may have a diameter of 3 inches, 4 inches, 5 inches, or more. As seen in FIG. 1, an optional vortex breaker 16 extends or projects from inlet 12 and includes a plurality of fins 17 formed about the periphery. The vortex breaker 16 extends into the bottom portion of the vessel or container 100. The vortex breaker 16, as its name implies, inhibits the formation or generation of a fluid vortex within the vessel or container 100 when the pump 10 or pump/mixer 70 is operating. In some embodiments of the pump 10 or pump/mixer 70 explained herein, the vortex breaker 16 may be omitted. This is seen, for example, in FIGS. 6A and 6B, 7, 9, 12, 16A, 16B, 17A-17C.

**[0018]** As seen in FIG. 1, the pump 10 or pump/mixer 70 includes one or more outlets 18. Each outlet 18 may carry the same volume of fluid or the different outlets 18 may carry varying or different amounts of fluid. The outlets 18 may optionally include, incorporate, or be connected to valves that can be used (e.g., actuated) to selectively turn on/off (or modulate flow through) the various outlets 18.

**[0019]** In the embodiment of FIG. 1, a plurality of outlets 18 are illustrated (i.e., three (3) outlets 18). In this particular embodiment, the outlets 18 are different sized (e.g., ¼ inch outlet, 1-inch OD outlet, 1-inch ID outlet). Of course, it should be appreciated that different sizes and types of outlets (e.g., outlet connector types) may be used with the pump 10 or pump/mixer 70. In still another embodiment, all of the outlets 18 are of the same size and/or type. The outlets 18 may be removably secured to the body of the pump 10 via fasteners 19 (e.g., bolts) as illustrated. With reference to FIG. 8, o-rings 75 may be used to seal the outlets 18 to the central housing 30 of the pump 10. The bottom of the pump 10 or pump/mixer 70 may include a flange 20 (FIG. 12) that is used to connect the pump 10 or pump/mixer 70 to a motor or drive unit 102 (as seen in FIGS. 1, 6B, 7, 8, 12, 13A, 13B, 14, 16A, 16B, 17B and 17C) using a sanitary clamp 104. The motor or drive unit 102 may include, for example, a brushless direct drive motor (e.g., AKM1™ Series motor available from Kollmorgen).

**[0020]** FIG. 2 illustrates an exploded view of the pump 10 or pump/mixer 70. Reference will be made to pump 10 for ease of reference and because there are no additional inlets making this embodiment a pump 10. As seen in FIG. 2, the pump 10 is formed from a number of assemblies or components that together create the pump 10. The pump 10 may be made from metal (e.g., stainless steel) or a polymer (e.g., polypropylene or polycarbonate, etc.) or combinations thereof. In some instances, the pump 10 or components thereof may be reusable (after appropriate sterilization or other hygienic cleaning). In

other embodiments, the pump 10 or components thereof may be single-use or disposable. This may include, as explained below, the upper housing 22, central housing 30, or bottom housing or plate 52.

**[0021]** The pump 10 (or pump/mixer 70 when including one or more additional inlets 72 as explained herein) includes an upper housing 22 that includes the main inlet 12 as well as an optional mount 13 (e.g., threaded opening that receives a threaded post) for the optional vortex breaker 16. Of course, when the vortex breaker 16 is omitted there is no need for a mount 13. The main inlet 12 includes a central opening that leads to a plurality of passageways 24 that extend through the upper housing 22. The upper housing 22 further includes a series of fasteners 26 (e.g., bolts) that secure the upper housing 22 to the central housing 30. The central housing 30 includes a central chamber 32 that holds pressurized fluid generated by the pumping action of the pump 10 (or pump/mixer 70) just prior to exiting the pump 10 via the one or more outlets 18. The central housing 30 includes a separate outer chamber 34 that circumscribes the central chamber 32 as an annulus. A wall thus separates outer chamber 34 from the central chamber 32. Two separate O-rings 36, 38 are interposed between the upper housing 22 and the central housing 30 with the O-rings 36, 38 located on the wall and outer perimeter of the outer chamber 34. The inner O-ring 36 is more robust or thicker than the outer O-ring 38 (due to the exposure to the higher pressure from the central chamber 32).

**[0022]** The central chamber 32 includes outlet passageways 40 (FIGS. 2-5, 9, 10, 11) for each of the outlets 18. The outlet passageways 40 allow pressurized fluid from the central chamber 32 to exit the pump 10 (or pump/mixer 70) via the outlets 18. As best seen in FIG. 3, fluid enters the central chamber 32 in the following manner with reference to arrow A. Fluid first enters the pump 10 via the main inlet 12 where the fluid then flows into the plurality of passageways 24. The fluid then enters the outer chamber 34. During operation of the pump 10, in response to actuation of the diaphragms 48 as explained herein, the fluid within this outer chamber 34 then passes through a corresponding check valve 42 that permits the one-way flow of fluid into a corresponding lower chamber 44 located in the central housing 30. The lower chambers 44 are separate from one another and are associated with a particular check valve 42. The fluid passes through a second one-way check valve 46 that permits the one-way flow of fluid into the central chamber 32. The check valves 42, 46 are polymeric check valves that open in one direction in response to a fluid pressure differential in one direction but remain closed when the fluid pressure differential is not present or reverses. For example, there may be three sets of check valves 42, 46 (a total of six for the three flow passages) although more or less may be used. The check valves 42 located in the outer chamber 34 are positioned symmetrically about the outer chamber 34 (e.g., about 120° apart from one another). A series of holes or apertures 35 (FIG. 4) permit the pas-

sage of fluid from the outer chamber 34 to a lower chamber 44 associated with each of the check valve 42 (fluid flows down; in one direction). The check valve 42 allows fluid flow through the holes or apertures 35 in the flow direction but blocks flow in the reverse (up) direction by covering the holes or apertures 35. The check valves 46 located in the central chamber 32 are also positioned symmetrically about the central chamber 32 (e.g., about 120° apart from one another in this embodiment) (FIG. 4). A series of holes or apertures 35 also permits the passage of fluid from the lower chambers 44 to the central chamber 32 associated with each of the check valve pair 42, 46 (fluid flows inward to the central chamber 32 in one direction as seen by arrow A). The check valve 42 allows fluid flow through the holes or apertures 35 in the flow direction but blocks flow in the reverse direction by covering the holes or apertures 35. While three (3) pairs of check valves 42, 46 and three diaphragms 48 are illustrated, in other embodiments, there may be different numbers. For example, a single pair of check valves 42, 46 and a single diaphragm 48 could be used. Preferably, there are a plurality of pairs of check valves 42, 46 and a plurality of diaphragms 48. While both even and odd numbers of check valve pairs and diaphragms 48 are contemplated, an odd number may be preferred in some embodiments so as to reduce unwanted pulsatile flow effects. This includes 3, 5, 7, 9, etc. diaphragms 48 and check valve pairs 42, 46. In other embodiments, an even number of diaphragms may be used (e.g., 2, 4, 6, 8, 10).

**[0023]** Flexible diaphragm(s) 48 (FIGS. 2, 3, 6B, 9) is/are located at the bottom of each lower chamber 44 and is used to "pull" and "push" fluid through the pump 10 (or pump/mixer 70). The flexible diaphragms 48 are held about their periphery in a bottom housing or plate 52 that is secured to the central housing 30 via one or more fasteners 50 (e.g., bolts). Each flexible diaphragm 48 is also secured at its central region to an actuating element 54 (e.g., FIGS. 2, 3, 6B, 9). Movement of the actuating element 54 in the up or down direction causes the flexible diaphragm 48 to move similarly in the up or down direction (e.g., opposing directions). When the flexible diaphragm 48 moves in a first or down direction, this pulls fluid into the lower chamber 44. Conversely, when the flexible diaphragm 48 moves in the second or up direction (e.g., opposing direction), this pushes fluid into the central chamber 32. This is what causes the "pull" and "push" of fluid through the pump 10 or pump/mixer 10.

**[0024]** In particular, sequential activation of diaphragms 48 is caused by actuating element(s) 54 secured to an actuating ring 56 (FIGS. 2, 3, 6B, 9) via fasteners 50 as seen in FIG. 9 (e.g., bolts) which are also attached to the actuating element(s) 54 or respective flexible diaphragm(s) 48 and move the diaphragm(s) 48 in the up/down direction. This causes the volume of each lower chamber 44 to either increase or decrease. Sequential activation of the diaphragms 48 is accomplished using a wobble plate or nutating disk 58 that is secured

to the actuating ring 56 (FIGS. 2, 6B and 8). The wobble plate or nutating disk 58 includes first and second bearings 60, 62 mounted in the center thereof. The inner bearing surfaces of bearings 60, 62 are secured to the shaft 65 of an eccentric drive shaft 64. The eccentric drive shaft 64 includes a shaft hole 68 that receives a motor shaft 69 of the motor or other drive unit 102. The motor shaft 69 is secured to the eccentric drive shaft 64 via a set screw 67 as illustrated in FIGS. 2 and 8. Rotation of the motor shaft 69 (which is secured to the eccentric drive shaft 64) causes the wobble plate or nutating disk 58 to sequentially actuate the actuating elements 54 with an up/down motion (via the wobble motion of the wobble plate or nutating disk 58). This up/down motion of the actuating elements 54 and secured diaphragms 48 creates the pumping action. For example, in a three diaphragm 48 configuration (first, second and third diaphragms 48), a first diaphragm 48 may move downward to pull fluid into the lower chamber 44 while the second and/or third diaphragms 48 may move upward to push fluid into the central chamber 32. The wobble plate or nutating disk 58 then "wobbles" to a next position/orientation to push the first diaphragm 48 upward while the second and/or third diaphragms 48 may move downward to pull fluid into the lower chamber 44 via the actuators/actuating element 54. This continues in sequential fashion to create the pumping action of the pump 10 (or pump/mixer 70).

**[0025]** FIG. 3 illustrates the direction of flow of fluid into the pump 10 or pump/mixer as shown by arrow A. Fluid flows downward from the main inlet 12 where the fluid then flows into the plurality of passageways 24. The fluid then enters the outer chamber 34. During operation of the pump 10, in response to actuation of the diaphragms 48 (in the down direction), the fluid within this outer chamber 34 then passes through a first check valve 42 that permits the one-way flow of fluid into a lower chamber 44 located in the central housing 30. Actuation of the diaphragm 48 in the opposite direction (in the up direction) in response to the actuating elements 54 pushes fluid into the central chamber 32. In particular, the fluid passes through a second check valve 46 into the central chamber 32. From the central chamber 32 the fluid which is under pressure can then leave the pump via the one or more outlets 18. Other pairs of first and second check valves 42, 46 operate in a similar manner.

**[0026]** As explained herein, in other embodiments, a combination pump/mixer device 70 (providing both pumping and mixing functionality) is provided (described herein as pump/mixer 70). This is illustrated in FIGS. 6A, 6B and 7-12, 13B, 14, 16A, 16B, 17A-17C. The pump/mixer device 70 is similar to the pump 10 described herein with the exception of a few modifications to the design. The pump/mixer device 70 includes the same components of the pump 10 as described above but adds

several additional elements. Those common elements use the same reference numbers as the pump 10 embodiment herein and will not be described again so as to avoid repetitive disclosure. The pump/mixer device 70 includes not only the top or upper "main" inlet 12 but also includes one or more additional inlets 72 that are located on the central housing 30 (or elsewhere on the pump/mixer device 70 such as upper housing 22 as seen in FIG. 12) and fluidically communicate with the central chamber 32 via inlet check valves 74 associated with each inlet 72 (best seen in FIGS. 6B, 8-11). The flow passage(s) that lead(s) from the inlet(s) 72 to the central chamber 32 may include jet structures (e.g., narrowed or tapered passageways as seen in FIG. 9) to further aid in mixing of the fluids in the central chamber 32. These jet structures may increase turbulent mixing that occurs within the central chamber 32. The central chamber 32 in the pump/mixer 70 embodiments effectively becomes a mixing chamber whereby the fluid from main inlet 12 and the additional inlet(s) 72 are able to mix with one another prior to being pumped out.

**[0027]** FIGS. 6A, 6B, 7, 8, 10, and 11 illustrate the central housing 30 showing five (5) additional inlets 72 and a single outlet 18 that communicate with the central chamber 32 and each additional inlet 72 has a corresponding check valve 74. The check valves 74 are one-way valves that let fluid enter the central chamber 32 from the inlets 72 but not in the opposite direction (i.e., fluid cannot flow out of the inlets 72 from the central chamber 32). The additional inlet(s) 72 may also be located on the upper housing 22 as illustrated in FIG. 12. For example, the additional inlets 72 may be located in both the upper housing 22 and the central housing 30. This provides the ability to locate a large number of inlets 72 about the periphery of the pump/mixer 70. This may also require increasing the size of the central chamber 32 to accommodate the check valves 74 in the wall of the central chamber 32.

**[0028]** The inlets 72 may be the same size and type. Of course, it should be appreciated that different sizes and types of inlets 72 (e.g., inlet connector types) may be used with the pump/mixer 70. These may be barbed inlets 72, inlets 72 with sanitary connections, and the like. The inlets 72 may optionally be removably secured to the body of the pump/mixer 70 via fasteners 19 (e.g., bolts) as illustrated. The inlets 72 may also be integrated into the body of the pump/mixer 70. In addition, in this embodiment, a single outlet 18 is illustrated. Other embodiments may include a plurality of outlets 18. For example, the pump/mixer 70 may include a plurality of inlets 72 and a plurality of outlets 18. The inlets 72 and outlet(s) 18 include O-rings 75 (FIG. 8) for a fluid-tight connection to the pump/mixer 70.

**[0029]** The outlet(s) 18 and inlet(s) 72 of the pump 10 or pump/mixer 70 may terminate in a variety of ends or connectors used in biopharmaceutical processes. These include hygienic connectors, barb locks, hose barbs, flanges, TC connectors, disposable aseptic connectors

(DAC), and the like. The outlet(s) 18 and inlet(s) 72 may optionally include or incorporate a valve directly or indirectly therein. Tubing or other conduit 112 (FIG. 14) may also interface with the outlet(s) 18 and inlet(s) 72 of the pump 10 or pump/mixer 70. The conduit 112 may be removably attached to the outlet(s) 18 and inlet(s) 72 of the pump 10 or pump/mixer 70. In still another embodiment, the outlet(s) 18 and inlet(s) 72 of the pump 10 or pump/mixer 70 may simply be an aperture or opening through which fluid passes. This aperture or opening may be threaded internally so that the outlet(s) 18 and/or inlet(s) 72 can accommodate a threaded connecting component or insert that interfaces with the threaded outlet(s) 18 and inlet(s) 72 of the pump 10 or pump/mixer 70.

**[0030]** FIG. 12 illustrates an embodiment of a pump/mixer 70 with a large number of additional inlets 72 (eleven (11) are illustrated in this embodiment). The number of outlets 18 and number of additional inlets 72 varies and is application specific. For some applications the pump/mixer 70 may only have a single outlet 18, however, other applications may include two (2), three (3), four (4), or five (5) outlets 18. Likewise, the number of inlets 72 is application dependent. This may include between one (1) and twenty (20) additional inlets 72. Larger sized pump/mixers 70 may include, for example, fifteen (15) to twenty (20) additional inlets 72. More typically, in smaller sized pump/mixers 70 there are typically less than ten (10) additional inlets. Each inlet 72 in this particular embodiment includes barbed ends that interface with conduits or tubing 112 (see e.g., FIG. 14). FIG. 12 further illustrate a sanitary clamp 104 that can be used to secure the pump-mixer 70 to the bottom of the container or vessel 100 such as illustrated in FIGS. 13A, 13B, and 14. Additional sanitary clamps 104 may be used to secure devices, devices, tubing (e.g., tubing 112) to the outlets 18.

**[0031]** FIG. 13A illustrates the operation of the pump 10 according to one embodiment. In this embodiment, a container or vessel 100 is provided with the pump 10 secured to the bottom or lower side via a port or coupler 101 (or other attachment scheme). A plurality of outlets 18 are located on the pump 10. The container or vessel 100 is filled with a fluid. The pump 10 is turned on by providing power the motor or other drive unit 102 secured to the pump 10. Fluid contained in the container or vessel 100 then enters the main inlet 12 as described herein and is pumped out the plurality of outlets 18. Arrows indicate the direction of flow. The speed of the motor or other drive unit 102 may be controlled to adjust the flow rate through the pump 10. This may occur through an automated controller or other control circuitry that is operably connected to the motor or drive unit 102.

**[0032]** FIG. 13B illustrates the operation of the pump/mixer 70 according to one embodiment. In this embodiment, a container or vessel 100 is provided with the pump/mixer 70 secured to the bottom or lower side via a port or coupler 101. In this embodiment, there is a single outlet 18 and a plurality of inlets 72 located on the

pump/mixer 70. The container or vessel 100 is filled with a fluid. The plurality of inlets 72 are fluidically connected via conduits, tubing, or the like (e.g., tubing 112 of FIG. 14) to one or more sources of fluid that have their own separate pumps 110 that pump fluid into the central chamber 32 such as that illustrated in FIG. 14. Note that the separate pumps 110 may in some embodiments include conventional pumps. In other embodiments, the separate pump(s) 110 may include the pumps 10 or pump/mixers 70 described herein (FIG. 14). The flow rate of the fluids through the plurality of inlets 72 may be individually controlled to adjust the mixing of fluids in the pump/mixer 70. For example, the flow rate of the fluids into the different additional inlets 72 may be controlled through the operation of the respective pump(s) 110 that is used to pump the applicable fluid into the pump/mixer 70. In addition, in some embodiments, valves may be incorporated into the plurality of inlets 72 (or fluidically coupled thereto) to selectively turn on/off various inlets 72 (or adjust flow into the inlets 72 or out of outlet 18). The pump/mixer 70 is turned on by providing power the motor or other drive unit 102 secured to the pump/mixer 70. Fluid contained in the container or vessel 100 then enters the main inlet 12 as described herein (illustrated by down arrow) and is mixed with the fluid(s) from the one or more inlets 72 inside the central chamber 32 and is pumped out the one or more outlets 18.

**[0033]** It should be appreciated that for an embodiment of a pump/mixer 70 that includes a plurality of additional inlets 72, respective fluids that are pumped into the additional inlets 72 into the pump/mixer 70 may be done simultaneously or sequentially. For example, consider a pump/mixer 70 that includes a main inlet 12 that receives fluid A, a single outlet 18, and three (3) additional inlets 72 each coupled to respective fluids B, C, and D. In one embodiment, the pump/mixer 70 operates to sequentially mix fluid A with fluid B, then mix fluid A with fluid C, then mix fluid A with fluid D. This may be done by sequentially pumping fluids B, C, and D into the pump/mixer 70 while it draws fluid A from the main inlet 12. Alternatively, fluids B, C, and D may be simultaneously mixed with fluid A by pumping the respective fluids into the three different additional outlets 70. Of course, different combinations thereof may also be used.

**[0034]** It should be appreciated that a plurality of pump 10 and/or pump/mixer 70 may be combined together in various systems depending on the application. For example, multiple pumps 10 and/or pump/mixers 70 may be combined to operate a dilution system whereby concentrated feedstock fluid media is subject to a dilution with a diluent such as water. Concentrated media may be pumped out of the container or vessel 100 using a pump 10 and/or pump/mixer 70. This output may then serve as the input to one or more additional downstream such as illustrated in FIG. 15. Likewise, the pump 10 and/or pump/mixer 70 may be used in connection with a container or vessel 100 (or multiple such containers or vessels 100) that is/are used as a bioreactor container

or vessel 100 as illustrated in FIGS. 16A, 16B, 17A-17C. Fluid contained in the bioreactor may be, for example, pumped using a pump and/or pump mixer 70 and subject to processing (e.g., filtration, aeration, gas exchange, and the like) and returned to the container or vessel 100. The additional inlets 72 may be used to mix the bioreactor contents with reagents, buffers, chemicals, and the like.

**[0035]** FIG. 15 illustrates one exemplary system 200 that is used to generate different buffer solutions as needed. The system 200 enables the generation of buffer solutions of different compositions and/or concentrations. The system 200 includes multiple pump/mixers 70a, 70b, 70c that are fluidically connected to respective containers or vessels 100a, 100b, 100c. Each container or vessel 100a, 100b, 100c contains a different buffer concentrate. While three (3) such different buffer concentrates are illustrated more or less may be used. Each pump/mixer 70a, 70b, 70c has two outlets 18a, 18b that lead to respective fluid paths (e.g., using conduits or tubing coupled to the outlets 18a, 18b). Valves 202 are located in the fluid paths that can be used to open/close the respective fluid flows from outlets 18a, 18b. Fluid paths 204a, 204b, 204c recirculate fluid back into the respective container or vessel 100a, 100b, 100c. Fluid paths 206a, 206b, 206c leads to additional inlets 72 of another pump/mixer 70d (e.g., in this example there are three (3) such inlets 72). This pump/mixer 70d is fluidically coupled to a container or vessel 100d that contains a diluent such as water. The water is used to dilute the concentrated buffer that arrives from fluid paths 206a, 206b, 206c. The pump/mixer 70d in combination with the container or vessel 100d operates as a dilution functional unit 208 as is illustrated.

**[0036]** The pump/mixer 70d includes three outlets 18c, 18d, 18e that lead to respective fluid paths 210, 212, 214. Valves 202 are located in the fluid paths 210, 212, 214 can be used to open/close the respective fluid flows from outlets 18c, 18d, 18e. A first outlet 18c leads to fluid path 210 enters another pump mixer 70e via an inlet 72. This pump/mixer 70e is fluidically coupled to a container or vessel 100e. The pump/mixer 70e includes two outlets 18f, 18g that lead to respective fluid paths 216, 218. Fluid path 216 recirculates fluid back into the container or vessel 100e. Fluid path 218 leads to the process 220 as illustrated in FIG. 15. The process 220 generically refers to any downstream process that requires the appropriate buffer. The second outlet 18d is located in fluid path 212 which leads to waste 222. The third outlet 18e is located in fluid path 214 and leads to another pump/mixer 70f via an inlet 72. This pump/mixer 70f is fluidically coupled to a container or vessel 100f. The pump/mixer 70f includes three outlets 18h, 18i, 18j that lead to respective fluid paths 224, 226, 228. Fluid path 224 leads to the process 220 as illustrated in FIG. 15. Fluid path 228 recirculates fluid back into the container or vessel 100f. Fluid path 226 is directed to another dilution functional unit 208. This additional dilution functional unit 208 operates similar to the pump/mixer 70d and associated container or

vessel 100d which is used to dilute the concentration of the buffer from container or vessel 100f. This is illustrated in FIG. 15, whereby a diluted buffer 230 (e.g., Buffer Y, concentration 2) is generated. This diluted buffer is then directed to process 220.

**[0037]** The system 200 of FIG. 15 is used to generate buffer fluids of different compositions and/or concentrations. In this example, buffer X is generated using the first dilution functional unit 208 that includes pump/mixer 70d and associated container or vessel 100d. The generated buffer X may be stored temporarily in container or vessel 100e until needed. The pump/mixer 70e can be used to recirculate buffer X to maintain the buffer and prevent, for example, precipitation of buffer species or constituents. Buffer Y is also generated using the first dilution functional unit 208 which is stored in container or vessel 100f. Note that water may be used to flush the pump/mixer 70d between creation of buffer X and buffer Y. This wash may be sent to waste 222. Buffer Y may be stored temporarily in container or vessel 100f until needed. The pump/mixer 70f can be used to recirculate buffer Y to maintain the buffer as explained herein. Buffer Y may be used in the process 220 using fluid path 224. Alternatively, buffer Y may need further dilution in which case fluid path 226 is used to direct buffer Y to another dilution functional unit 208 to create diluted buffer Y (e.g., buffer Y at concentration 2). This diluted buffer can then be sent to the process 200.

**[0038]** It should be appreciated that FIG. 15 illustrates one illustrative embodiment of a system 200 that uses a constellation of pump/mixers 70. Different configurations and modifications may be made depending on the need. Different numbers of pump/mixers 70 (or pumps 10) may be used. The pump/mixers 70 that are used may include different numbers of additional inlets 72 and outlets 18 may be used. Additional levels or cascades of pumps/mixers 70 may be used as well.

**[0039]** FIGS. 16A, 16B, 17A-17C illustrate embodiments in which the pump/mixer 70 is used in connection with a container or vessel 100 used as a bioreactor (these may include flexible bags as illustrated or other rigid containers as explained herein). The pump/mixer 70 is coupled to each container or vessel 100 via a port or coupler 101 as seen in FIG. 16B. Of course, it should be appreciated that the pump/mixer 70 may be secured to the container or vessel 100 via different couplings or even integrated directly into the container or vessel 100. For example, the pump/mixer 70 may be welded to or thermally/chemically bonded to the container or vessel 100. Regardless of the mode of connection, the main inlet 12 of the pump/mixer 70 is in fluid communication with the interior of the container or vessel 100.

**[0040]** The bioreactor may be used to grow, culture, or maintain live cells or other organisms. FIGS. 16A and 16B illustrates two containers or vessels 100 (i.e., two bioreactors) each coupled to their own respective pump/mixer 70. Fluid from the container or vessel 100 enters the main inlet 12 of the pump/mixer 70 as ex-

plained herein previously. Each pump/mixer 70 includes multiple outlets 18, some of which, lead to fluid-carrying conduits or lines 240, 242 that ultimately return to the container or vessel 100. As seen in FIGS. 16A and 16B, fluid conduit or line 240 includes a gas transfer unit 244 interposed in the flow path and is used to gas transfer and/or exchange. Fluid conduit or line 242 includes a filter unit 246 interposed in the flow path and is used for filtration. After passing through gas transfer unit 244 and filter unit 246, the respective fluid conduits or lines 240, 242 return flow to the container or vessel 100 via ports 248. In one preferred embodiment, the ports 248 are located in the top of the container or vessel 100. In this regard, the ports 248 are located above the fluid level contained in the container or vessel 100 which is advantageous as it avoids possible leaks. Each port 248 is connected to respective outlet lines 250 that terminate at various depths or locations within the container or vessel 100. Additional ports 249 may be provided on the container or vessel 100 that are used to input fluids, gases, or even solids into the interior of the container or vessel 100.

**[0041]** Each pump/mixer 70 includes one or more additional inlets 72 that are used to introduce fluids for mixing into the pump/mixer 70 via conduit or line 252. The inlet(s) 72 may be used to adding buffers, wash fluid, other fluids, chemicals, reagents, special cell nutrients, drugs or therapeutics, and the like as needed by the particular process taking place in the bioreactor. The pump/mixer 70 may include additional outlets 18 that are used to evacuate the contents of the container or vessel 100 or for transport to another downstream processing operation. While FIGS. 16A and 16B illustrate a gas transfer unit 244 and a filter unit 246, it should be understood that other operations may be optionally integrated into fluid conduits/lines 240, 242 (in some embodiment these may be omitted and lines 240, 242 just serve as return lines). As seen in FIG. 16A and 16B, the pump/mixers 70 are supported by a housing or base 254. The housing or base 254 contains the motors or drive units 102 and electronics used to power and drive the pump/mixers 70.

**[0042]** FIGS. 17A-17C illustrate another embodiment of a container or vessel 100 that is used as a bioreactor. This embodiment illustrates a pump/mixer 70 with one or more inlets 72 and multiple outlets 18 secured to the bottom of the container or vessel 100 via a port or coupler 101 using a sanitary clamp 104 (other attachment scheme). The main inlet 12 to the pump/mixer 70 is located at the bottom of the container or vessel 100. In this embodiment, there are five (5) outlets with four (4) of the outlets leading to respective fluid-carrying conduits or lines 260, 262, 264, 266 that eventually return fluid to the container or vessel 100. The additional inlets 72 are coupled to fluid-carrying tubing or conduits 73 that carry fluid that enters the inlets 72 of the pump/mixer 70 for mixing with the fluid that enters the main inlet 12. As with the embodiment of FIGS. 16A, 16B, one or more processing

units may be interposed in the conduits or lines 260, 262, 264, 266. These may include, for example, a gas transfer unit 244, a filter unit 246, or the like. Ports 248 are provided at the top of the container or vessel 100 that are connected to respective outlets lines 250 that terminate at various locations with the container or vessel 100. In this particular embodiment, the container or vessel 100, which is a flexible bag, is held within a frame 270 that includes a bottom surface and side walls to hold the flexible bag (one wall is omitted for clarity purposes). Of course, other ways of holding the container or vessel 100 are contemplated. For example, the flexible bag may be secured within a dolly or carrier or held in place with hooks, retainers, or the like. As with the prior embodiment, a housing or base 254 supports the pump/mixer 70 and contains the motor or drive unit 102 and electronics used to power and drive the pump/mixer 70.

**[0043]** One advantage of the bioreactor embodiments of FIGS. 16A-16B, 17A-17C is that mixing takes place inside the pump/mixer 70 and is then transferred into the container or vessel 100 via ports 248 located at the top of the container. These ports 248 are located above the fluid line to thereby reduce risk of leaks and/or contamination. In addition, this reduces the total number of ports as the return lines 240, 242, 260, 262, 264, 266 are used to carry mixed fluid in addition can be used to recirculate fluid within the bioreactor. Mixing feeds can be directly input to the pump/mixer 70 and there is no need for a separate inlet port to the container or vessel 100 and no need for agitators and/or mixers within the container or vessel 100. Conditions inside the container or vessel 100 can be tuned as needed by controlling the input feeds to the additional inlets 72 and also running the bioreactor contents through one or more external processing units. For example, these processing units (e.g., a gas transfer unit 244) can perform gas exchange similar to the way a person's lungs operate to exchange oxygen and carbon dioxide during respiration. Likewise, a filter unit 246 may eliminate waste products and operate similar to a person's liver or kidneys. At the same time, the input conditions to the container or vessel 100 can be adjusted or tuned by adjusting the compositions and/or flow rates of input fluids to the interior of the container or vessel 100 (e.g., to adjust or tune the growth media present therein). It should be appreciated that the specific bioreactor setups illustrated in FIGS. 16A-16B and 17A-17C are exemplary. Different bioreactor setups appropriate for a particular application(s) can be used that incorporate the pump/mixer(s) 70.

**[0044]** The pumps 10 and/or pump/mixers 70 may also be used in industrial applications. For example, the 10 and/or pump/mixers 70 may be used with Intermediate Bulk Containers (IBC). IBCs are used to storing and transporting bulk quantities of materials including fluids or liquids. The contents of IBCs serving as the container or vessel 100 may be pumped and/or mixed using the pumps 10 and/or pump/mixers 70. The pumps 10 and/or pump/mixers 70 may also be used in food manufacturing

applications to mix and/or pump food ingredients, additives, or the like. While the pumps 10 and/or pump/mixers 70 are principally designed to operate on fluids or liquids that are contained in the container or vessel 100 it should be appreciated that some applications (such as food) may involve some solid materials or contents that may be viscous or have fluid-like properties. The pumps 10 and/or pump/mixers 70 may also be used in semiconductor or other industrial applications.

**[0045]** While embodiments of the present invention have been shown and described, various modifications may be made without departing from the scope of the present invention. Moreover, it should be appreciated that aspects of one embodiment may be utilized in other embodiments described herein. Thus, features of one embodiment may be substituted or used in other embodiments. A pump/mixer 70 may also be used as a pump 10 if the inlets 72 are closed (e.g., by using valve(s) or the like) or plugged. In addition, while the pumps 10 and pump/mixers 70 illustrated herein are oriented vertically, it should be appreciated that some configurations may include the pumps 10 and pump/mixers oriented in a horizontal configuration. In this embodiment, an elbow or 90-degree conduit/port or coupler 101 may secure the container or vessel 100 to the pump 10 or pump/mixer 70. In addition, while the embodiments described herein have largely been described being used in the context of a bioprocess or pharmaceutical operation, the embodiments are not limited to those applications. For example, the concepts and embodiments described herein may be applied to high purity chemical systems or in other industries. The invention, therefore, should not be limited except to the following claims.

at least one outlet (18) fluidically connected to the central chamber (32);  
 one or more additional inlets (72) fluidically coupled to the central chamber (32) via respective inlet check valve(s) (74); and  
 a moveable diaphragm (48) disposed in each of the plurality of lower chambers (44), the moveable diaphragms (48) interfacing with a respective actuating element (54) driven by a wobble plate or nutating disk (58) operatively coupled to a motor or drive unit (102), wherein actuation causes each of the moveable diaphragms (48) to move in opposing directions.

- 5
  - 10
  - 15
  - 20
  - 25
  - 30
  - 35
  - 40
  - 45
  - 50
  - 55
2. The pump/mixer device (70) of claim 1, wherein the pump/mixer device (70) comprises a plurality of outlets (18).
  3. The pump/mixer device (70) of claim 1, wherein the pump/mixer device (70) comprises a plurality of additional inlets (72).
  4. The pump/mixer device (70) of any of claims 1-3, wherein the wobble plate or nutating disk (58) is coupled to the motor or drive unit (102) by an eccentric drive shaft.
  5. The pump/mixer device (70) of claim 1, wherein the number of moveable diaphragms (48) comprises an odd number of diaphragms.
  6. The pump/mixer device (70) of claim 1, wherein the number of moveable diaphragms (48) comprises an even number of diaphragms.
  7. The pump/mixer device (70) of claim 1, wherein the one or more additional inlets (72) are removable from the pump/mixer device (70).
  8. The pump/mixer device (70) of claim 1, wherein the at least one outlet (18) is removable from the pump/mixer device (70).
  9. The pump/mixer device (70) of claim 1, wherein the one or more additional inlets (72) are fluidically connected to a flow passage comprising a jet structure formed therein adjacent to respective inlet check valves (74).
  10. The pump/mixer device (70) of claim 1, further comprising a vortex breaker (16) that extends or projects from the main inlet (12) and includes a plurality of fins formed about the periphery thereof.
  11. The pump/mixer device (70) of claim 1, wherein the pump/mixer device (70) is removable from the vessel or container (100).

**REFERENCES CITED IN THE DESCRIPTION**

*This list of references cited by the applicant is for the reader's convenience only. It does not form part of the European patent document. Even though great care has been taken in compiling the references, errors or omissions cannot be excluded and the EPO disclaims all liability in this regard.*

**Patent documents cited in the description**

- US 20170135532 A1 [0005]
- CN 108661892 A [0006]
- WO 2018144391 A1 [0007]

## PUMPE/BLANDERANORDNING

PATENTKRAV

1. Pumpe/blanderanordning (70), der omfatter:
  - 5 et hovedindløb (12) placeret ved en top eller et øvre område af pumpe/blanderanordningen (70), hvilket hovedindløb (12) er konfigureret til at blive fastgjort til eller integreret i en bund af et kar eller en beholder (100);
    - et ydre kammer (34) placeret i pumpe/blanderanordningen (70) og fluidmæssigt forbundet med hovedindløbet (12);
    - 10 en flerhed af nedre kamre (44) placeret i pumpe/blanderanordningen (70) under det ydre kammer (34) og fluidmæssigt forbundet med det ydre kammer (34) af respektive kontraventiler (42) indsat mellem det ydre kammer (34) og flerheden af nedre kamre (44);
      - et centralt kammer (32) placeret i pumpe/blanderanordningen (70), hvilket centralt kammer (32) er fluidmæssigt forbundet med flerheden af nedre kamre (44) med
      - 15 respektive kontraventiler (46) indsat mellem det centrale kammer (32) og flerheden af nedre kamre (44);
        - mindst ét udløb (18) fluidmæssigt forbundet med det centrale kammer (32);
        - ét eller flere supplerende indløb (72) fluidmæssigt koblet til det centrale kammer (32) via én eller flere respektive indløbskontraventiler (74) og
        - 20 en bevægelig membran (48) placeret i hver af flerheden af nedre kamre (44), hvor de bevægelige membraner (48) danner grænseflade med et respektivt aktiveringselement (54) drevet af en svingplade eller nutationsskive (58), der er operativt koblet til en motor eller et drivenhed (102), hvor aktivering bevirker, at hver af de bevægelige membraner (48) bevæger sig i modsatte retninger.
  - 25
2. Pumpe/blanderanordning (70) ifølge krav 1, hvor pumpe/blanderanordningen (70) omfatter en flerhed af udløb (18).
3. Pumpe/blanderanordning (70) ifølge krav 1, hvor pumpe/blanderanordningen (70) omfatter en flerhed af supplerende indløb (72).
- 30

4. Pumpe/blanderanordning (70) ifølge et hvilket som helst af kravene 1-3, hvor svingpladen eller nutationsskiven (58) kobles til motoren eller drivenheden (102) af en excentrisk drivaksel.
- 5 5. Pumpe/blanderanordning (70) ifølge krav 1, hvor antallet af bevægelige membraner (48) omfatter et ulige antal membraner.
6. Pumpe/blanderanordning (70) ifølge krav 1, hvor antallet af bevægelige membraner (48) omfatter et lige antal membraner.
- 10 7. Pumpe/blanderanordning (70) ifølge krav 1, hvor det ene eller flere supplerende indløb (72) kan fjernes fra pumpe/blanderanordningen (70).
8. Pumpe/blanderanordning (70) ifølge krav 1, hvor det mindst ene udløb (18) kan fjernes fra pumpe/blanderanordningen (70).
- 15 9. Pumpe/blanderanordning (70) ifølge krav 1, hvor det ene eller flere supplerende indløb (72) fluidmæssigt forbindes med en strømningspassage omfattende en strålestruktur dannet deri stødende op til de respektive indløbskontraventiler (74).
- 20 10. Pumpe/blanderanordning (70) ifølge krav 1, og som endvidere omfatter en hvirvelbryder (16), der strækker sig fra eller står frem fra hovedindløbet (12) og indbefatter en flerhed af finner dannet omkring periferien deraf.
- 25 11. Pumpe/blanderanordning (70) ifølge krav 1, hvor pumpe/blanderanordningen (70) kan fjernes fra karret eller beholderen (100).
12. Pumpe/blanderanordning (70) ifølge krav 1, og som omfatter et øvre hus (22), der indeholder hovedindløbet (12), et centralt hus (30), der indeholder flerheden af nedre kamre (44) og det centrale kammer (32), og et bundhus eller en bundplade (52), der indeholder de bevægelige membraner (48) og er fastgjort til det centrale hus (30).
- 30

13. Pumpe/blanderanordning (70) ifølge krav 1, hvor det mindst ene udløb (18) er fluidmæssigt forbundet med det centrale kammer (32) via én eller flere respektive udløbskontraventiler.
- 5 14. Fremgangsmåde til anvendelse af pumpe/blanderanordningen (70) ifølge et hvilket som helst af kravene 1-13, og som omfatter:
- drift af motoren eller drivenheden (102) for at aktivere svingpladen eller nutationsskiven (58);
  - indføring af et første fluid fra karret eller beholderen (100) i hovedindløbet (12);
  - 10 indføring af et andet eller supplerende fluider i pumpe/blanderanordningen (70) via det ene eller flere supplerende indløb (72);
  - blanding af det første fluid og det andet eller supplerende fluider i pumpens/blanderens (70) centrale kammer (32) og
  - udføring af det blandede fluid via det mindst ene udløb (18).
- 15
15. Fremgangsmåde ifølge krav 14, hvor det andet eller supplerende fluider indføres i pumpe/blanderanordningen (70) af én eller flere supplerende pumper.
16. Fremgangsmåde ifølge krav 14, hvor det ene eller flere supplerende udløb (72) 20 indeholder eller kobles til respektive ventiler, og én eller flere af de respektive ventiler aktiveres for at initiere og/eller standse strømmen af det andet eller supplerende fluider ind i pumpe/blanderanordningen (70).
17. Fremgangsmåde ifølge krav 14, hvor det andet eller supplerende fluider omfatter 25 et bufferfluid eller et opkoncentreret fluid.

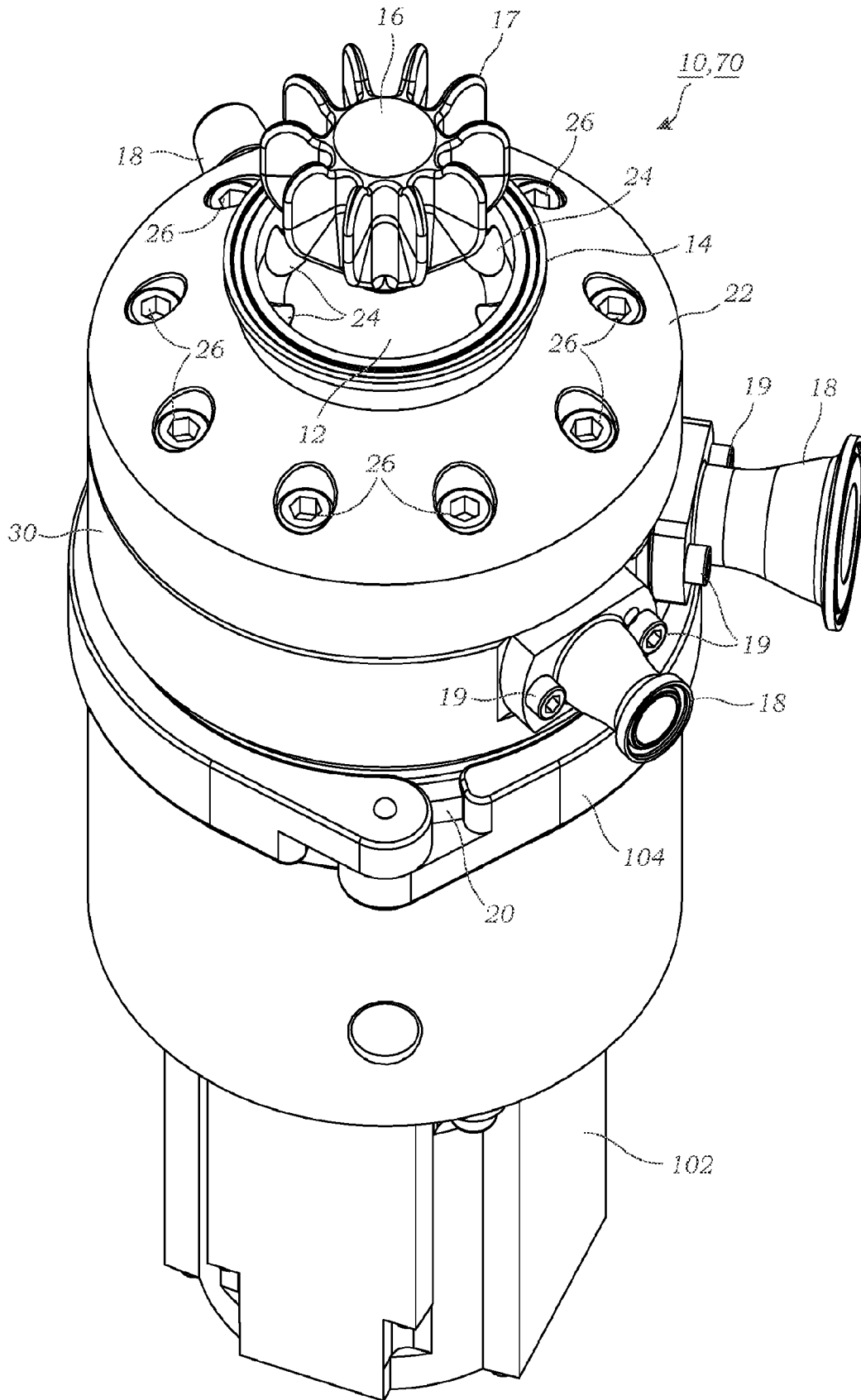

FIG. 1

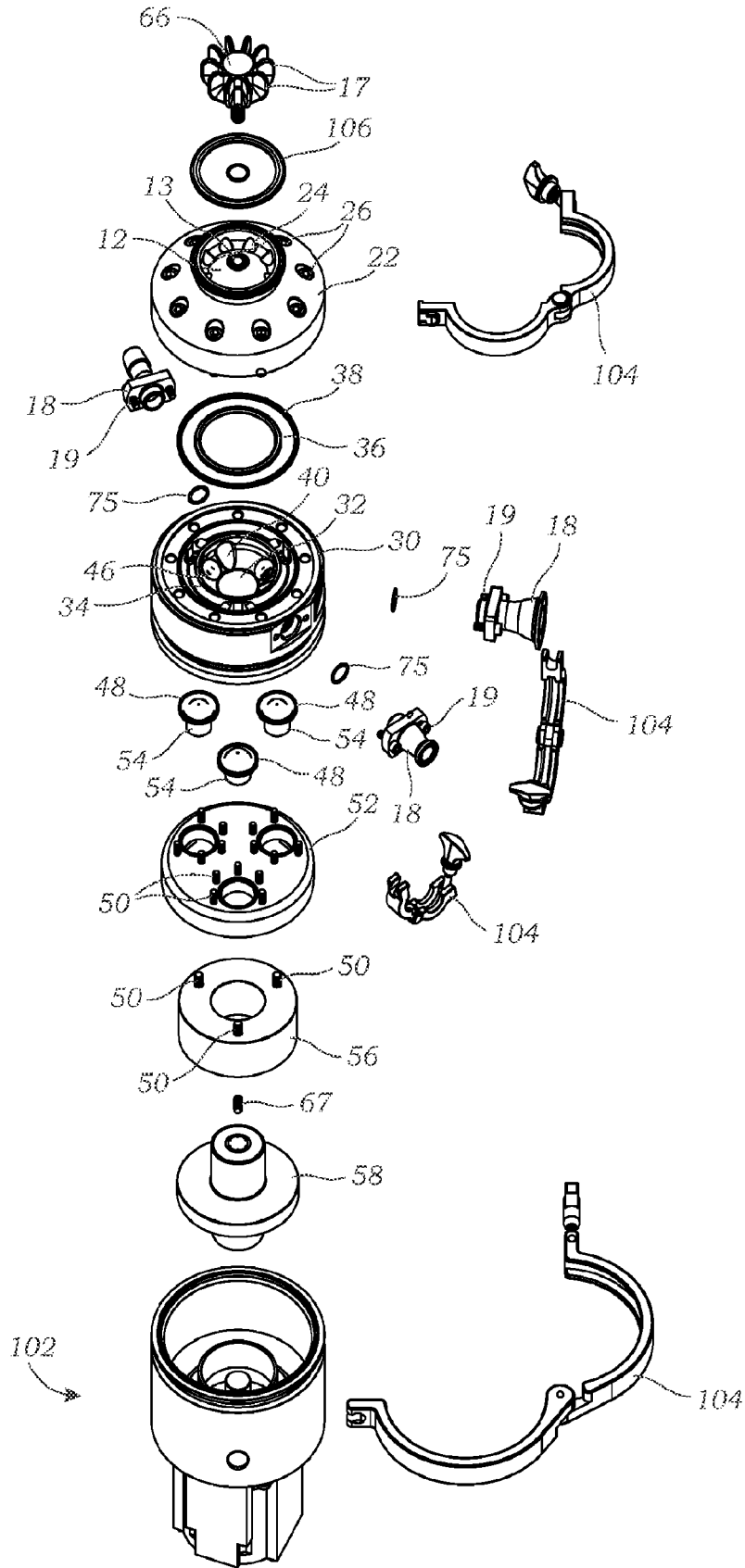

FIG. 2

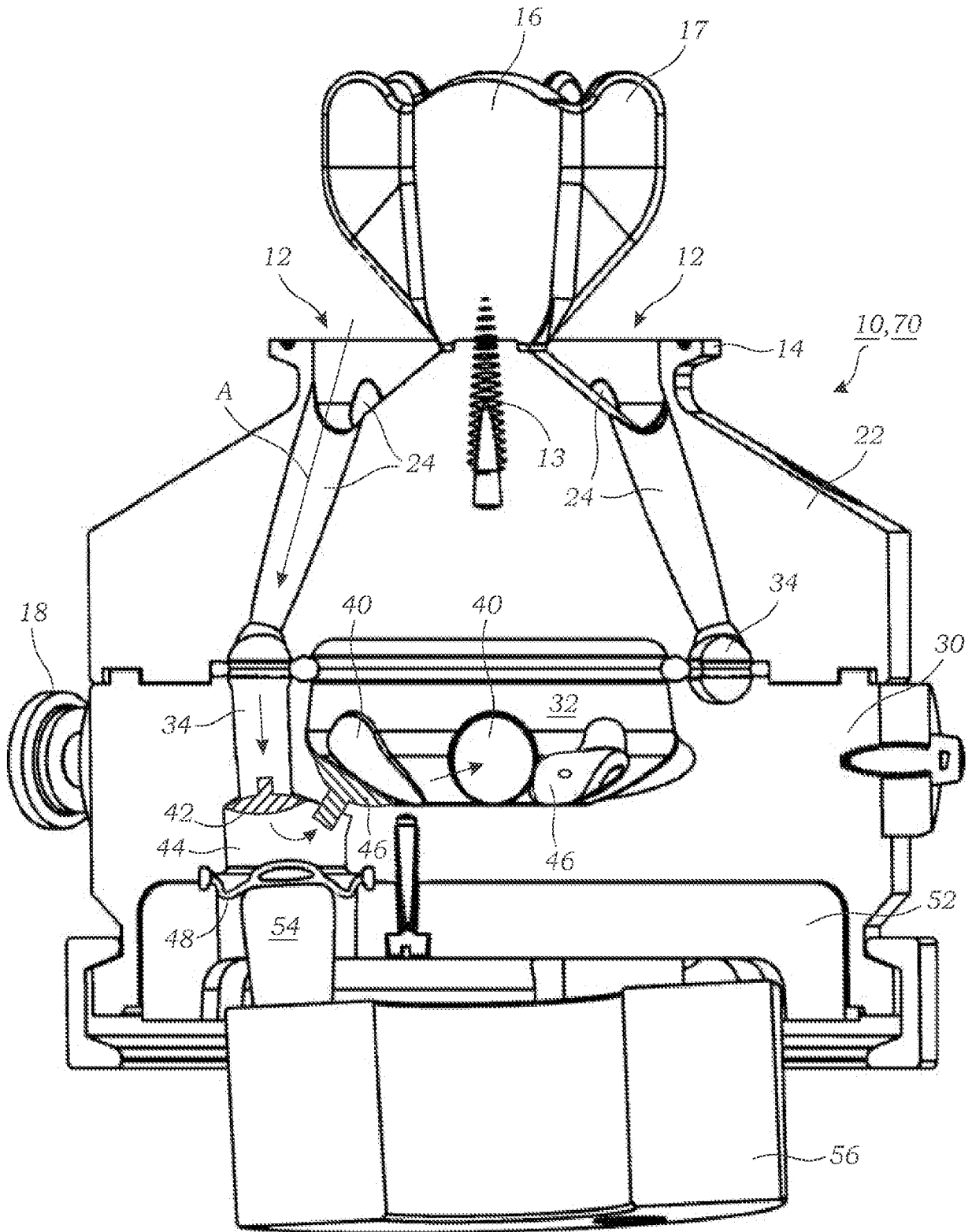

FIG. 3

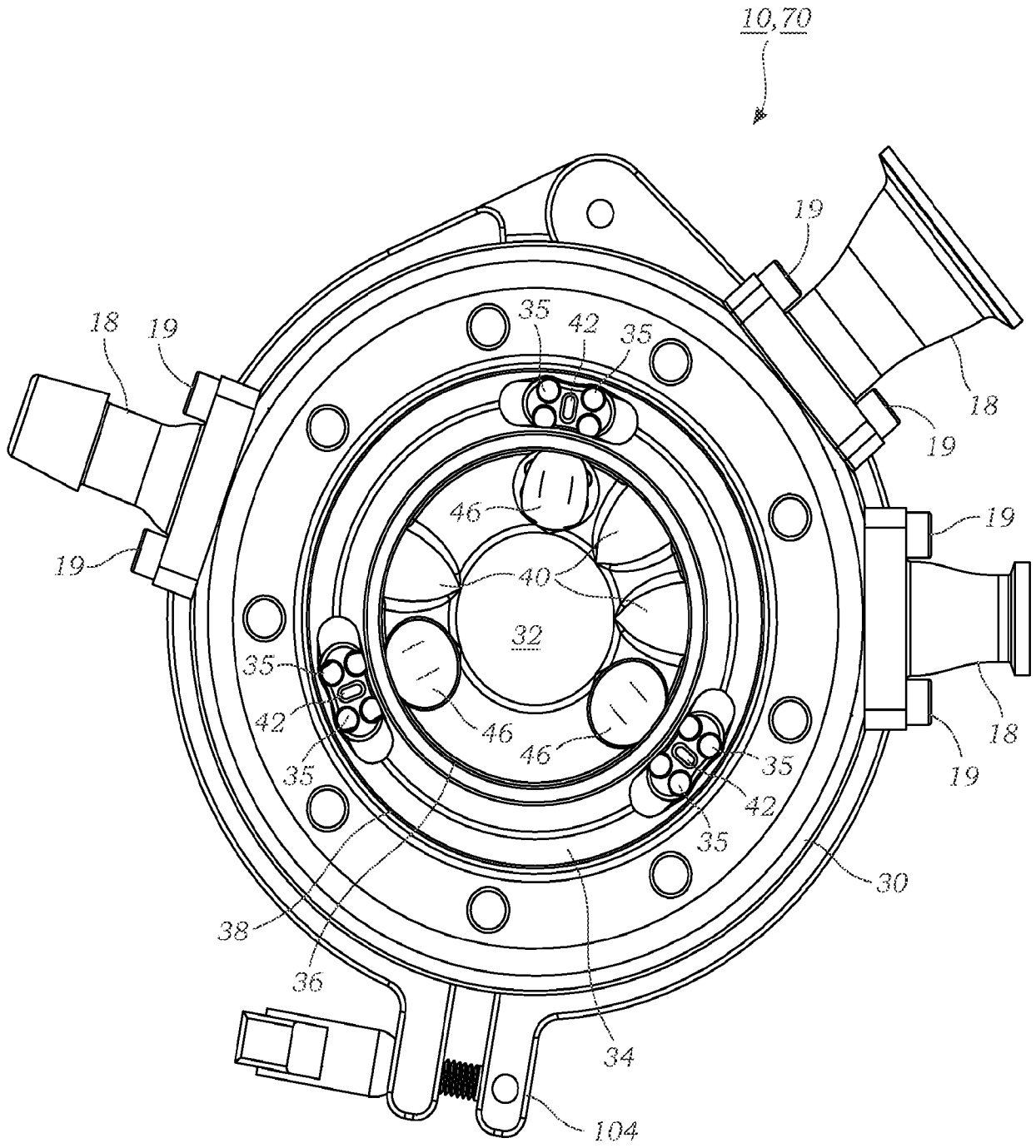

FIG. 4

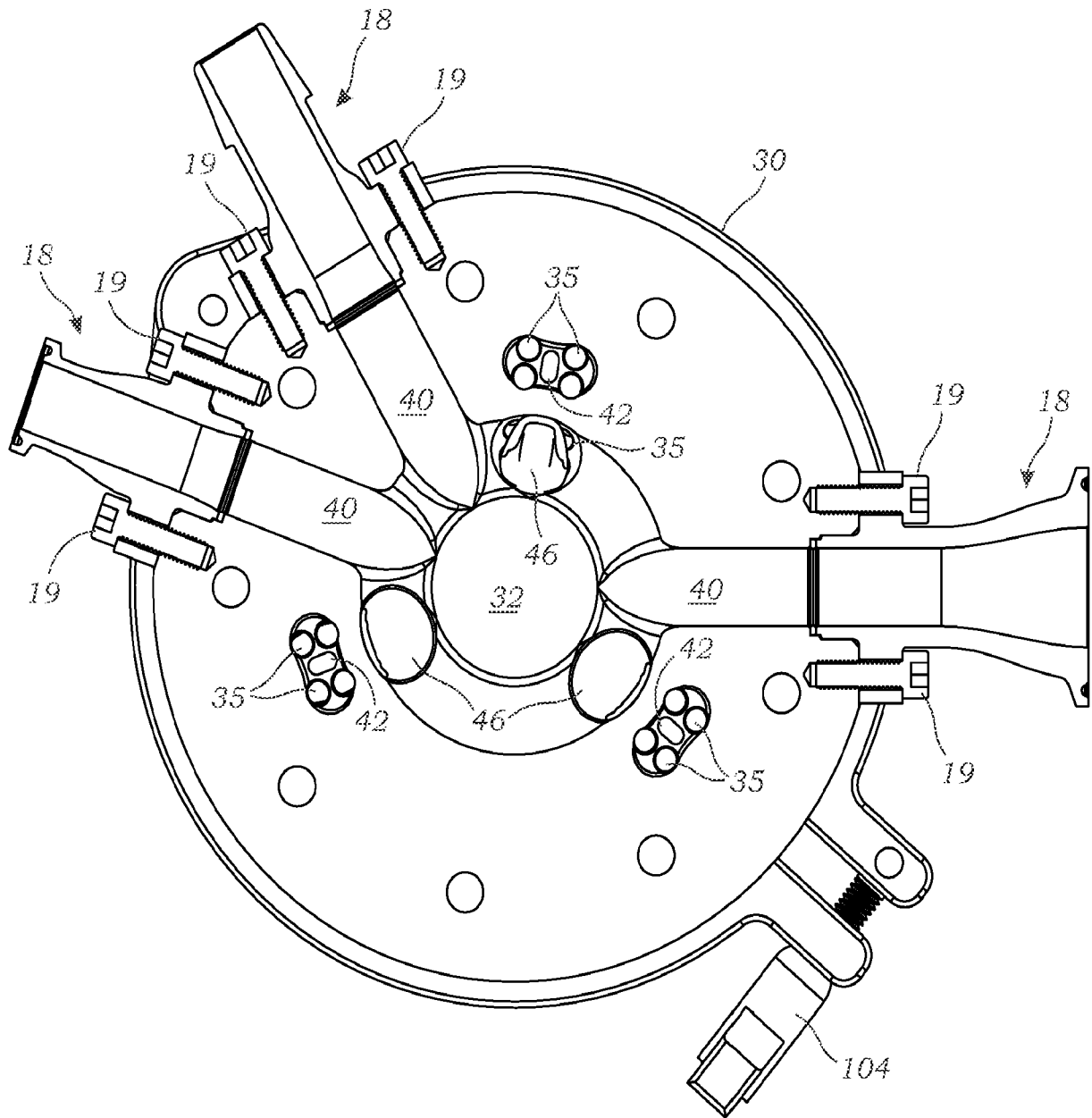

FIG. 5

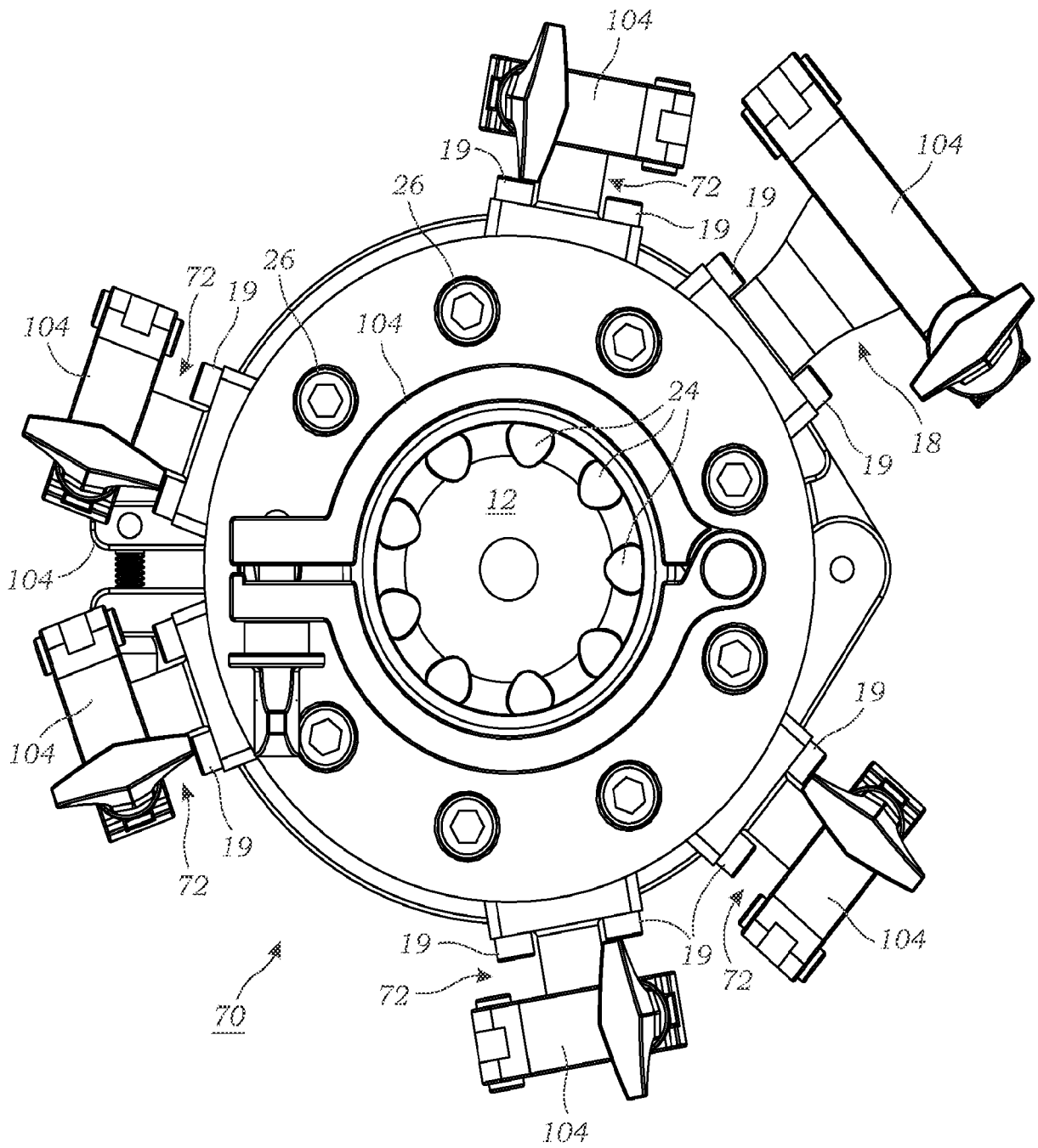
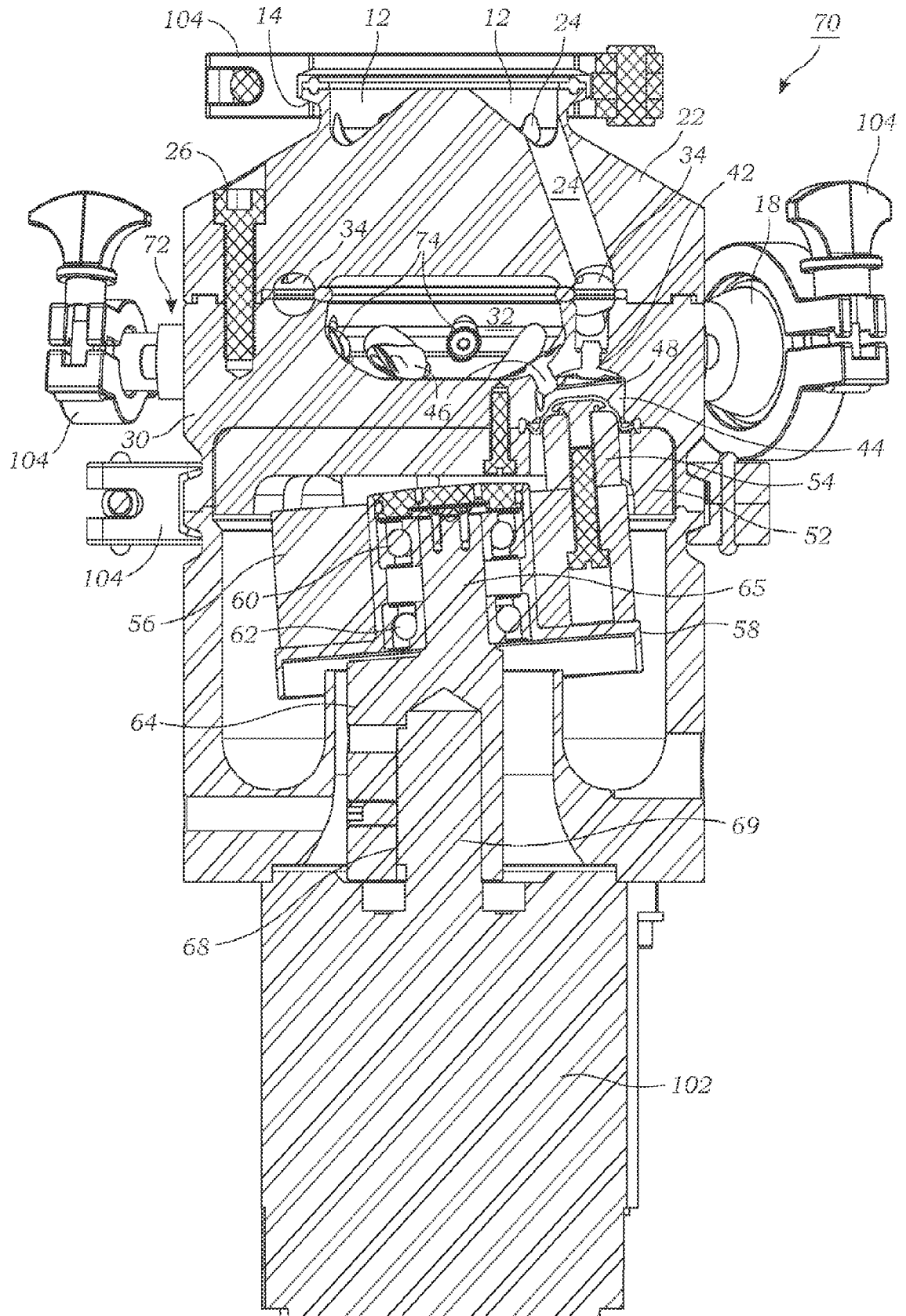

FIG. 6A



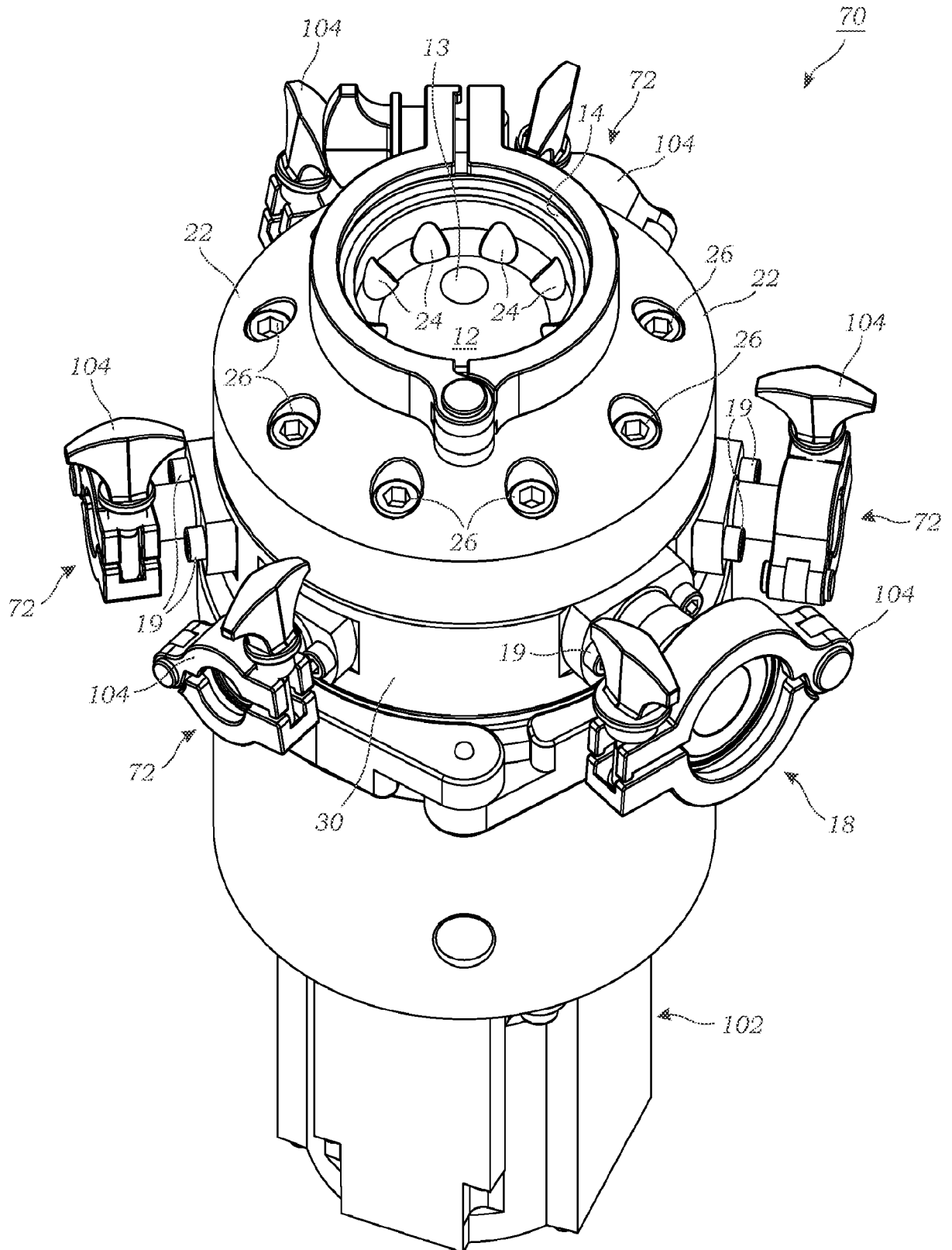

FIG. 7



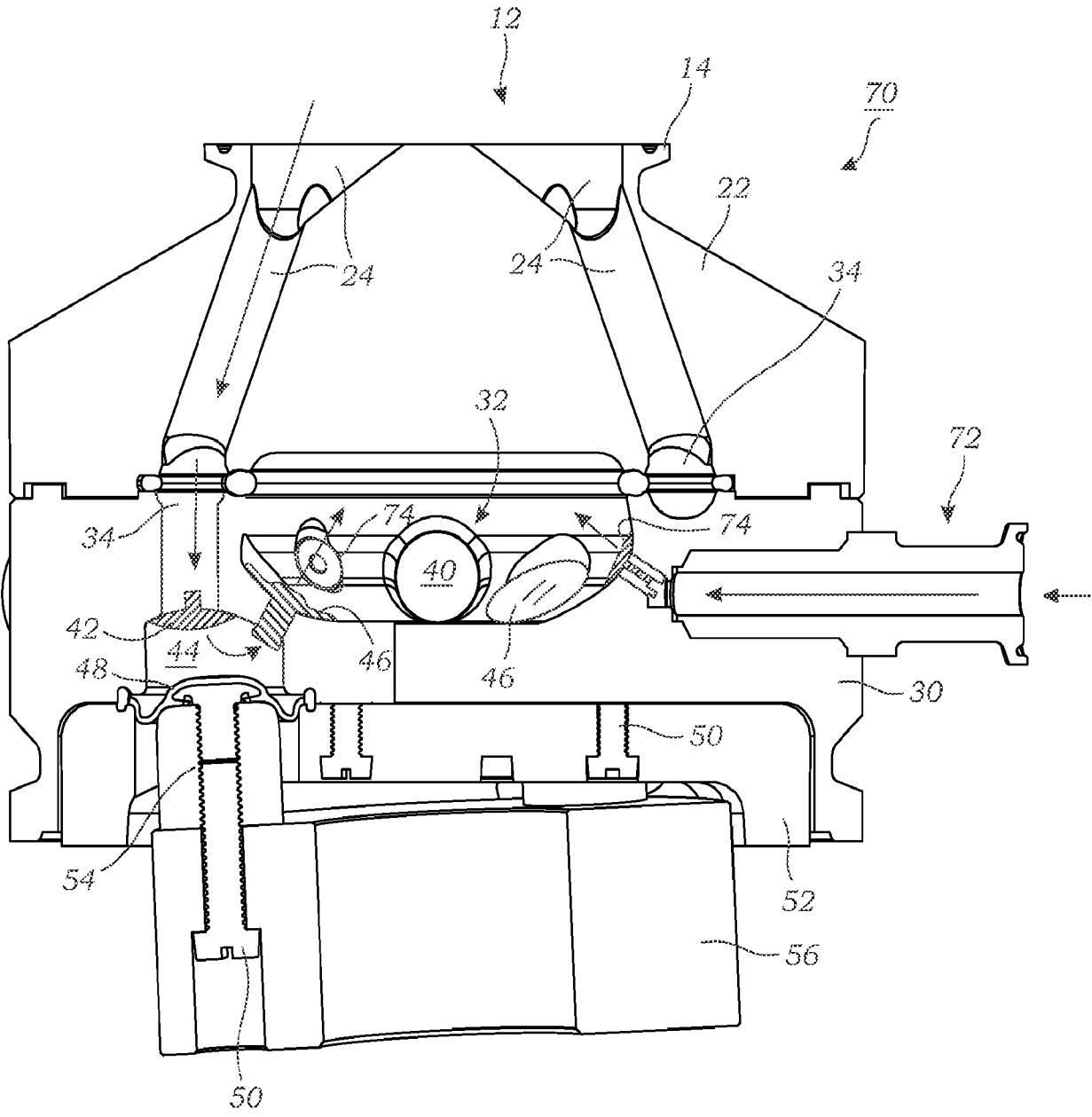

FIG. 9

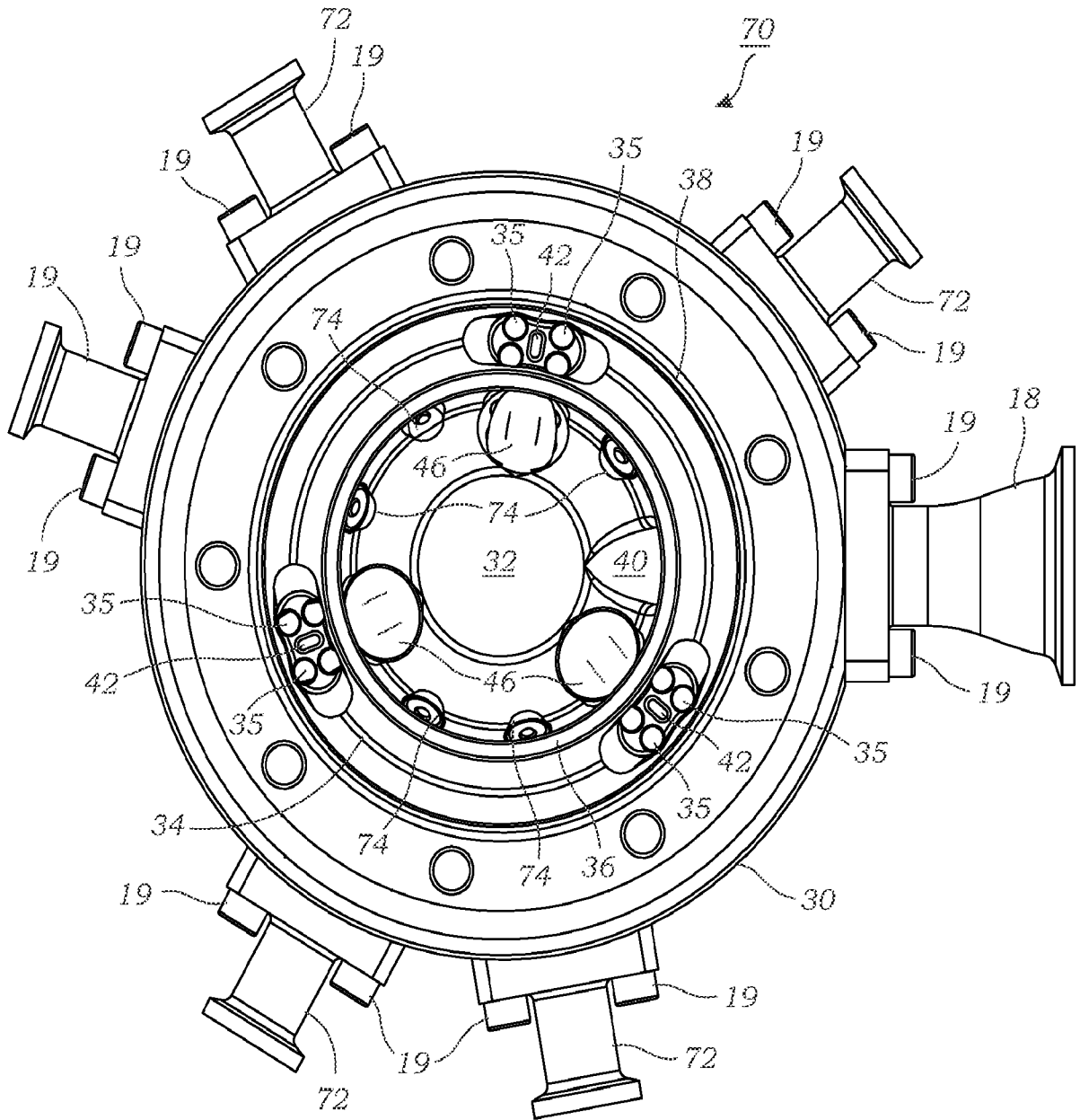

FIG. 10

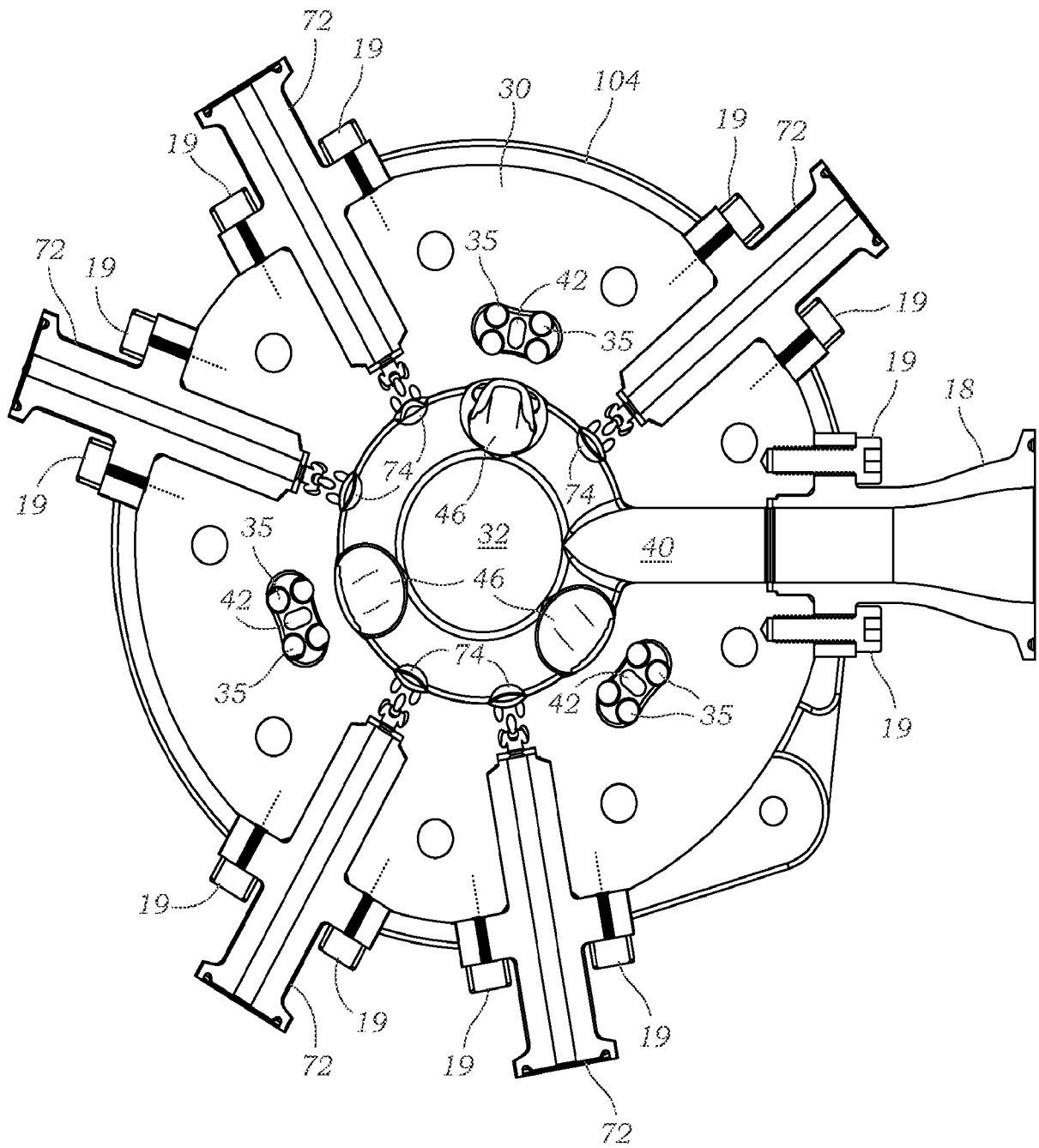

FIG. 11

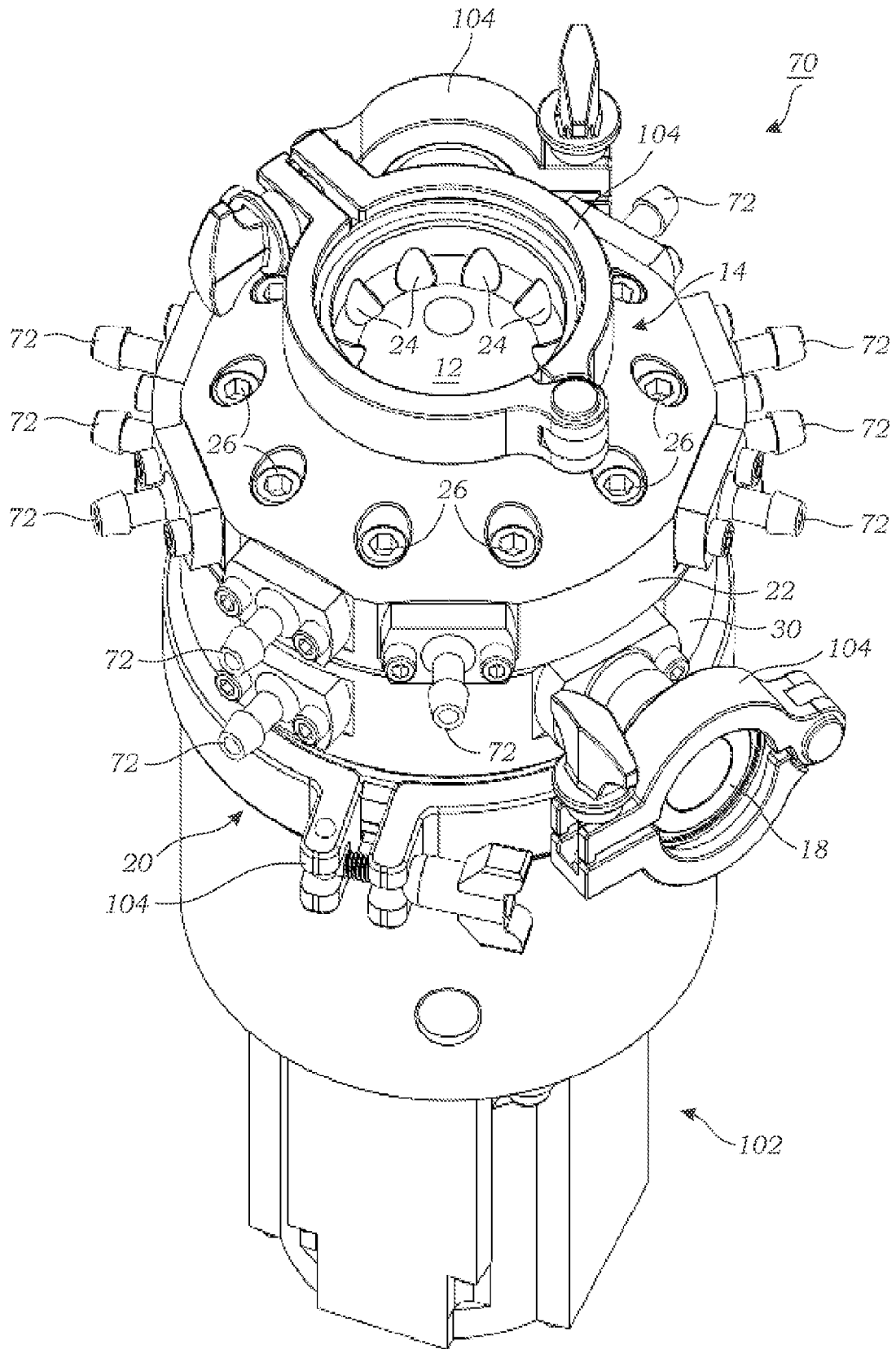

FIG. 12

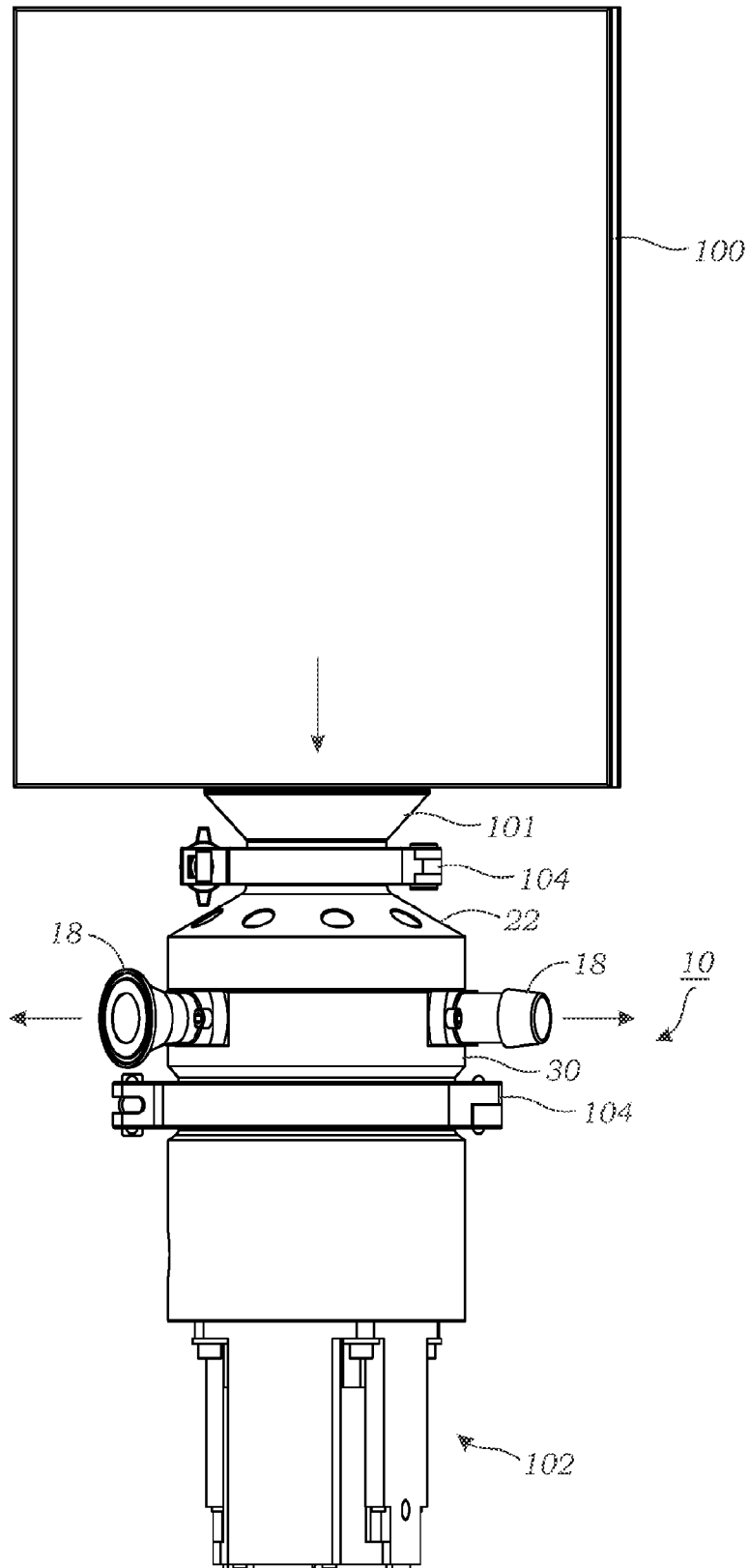

FIG. 13A

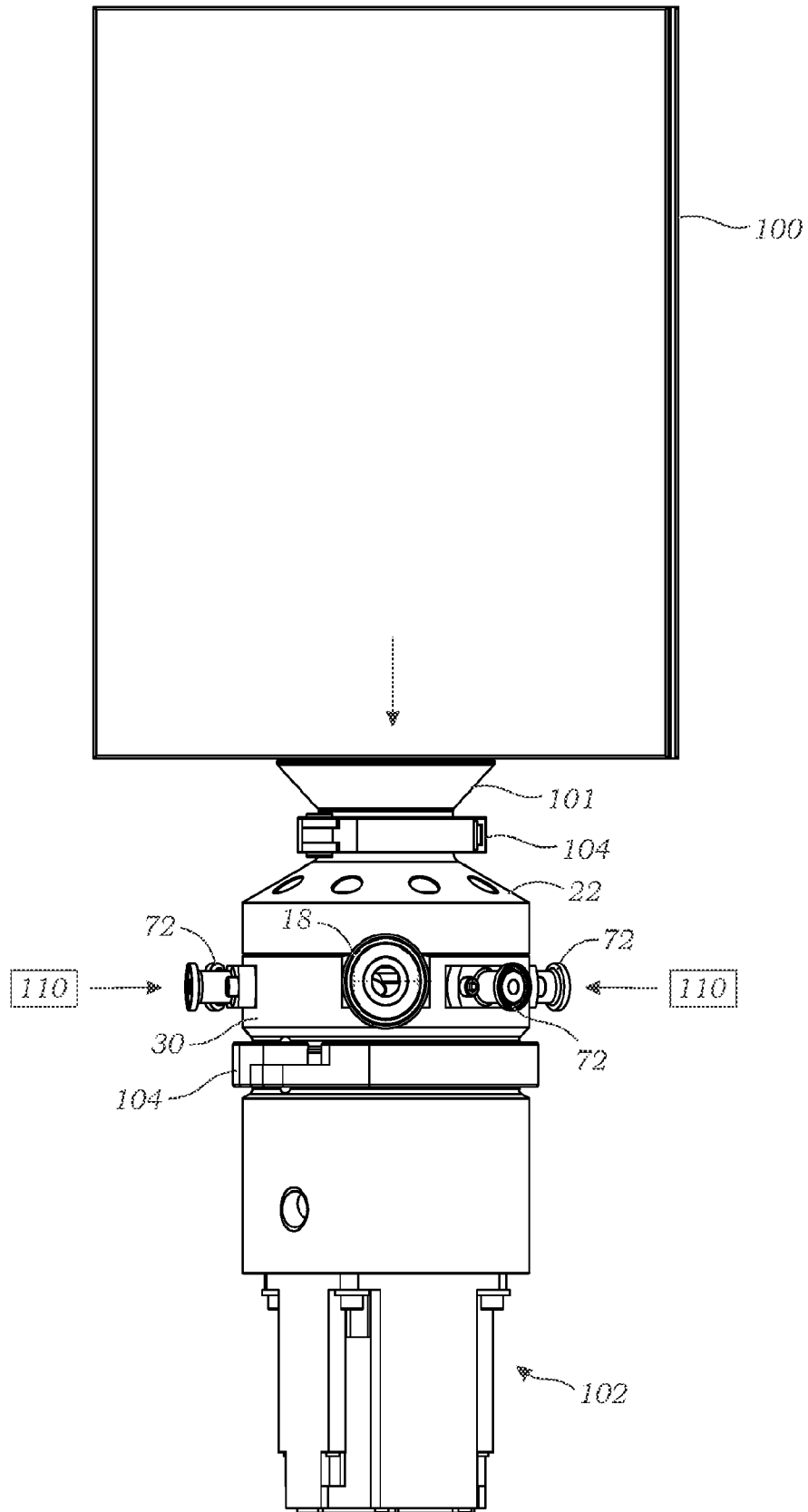

FIG. 13B

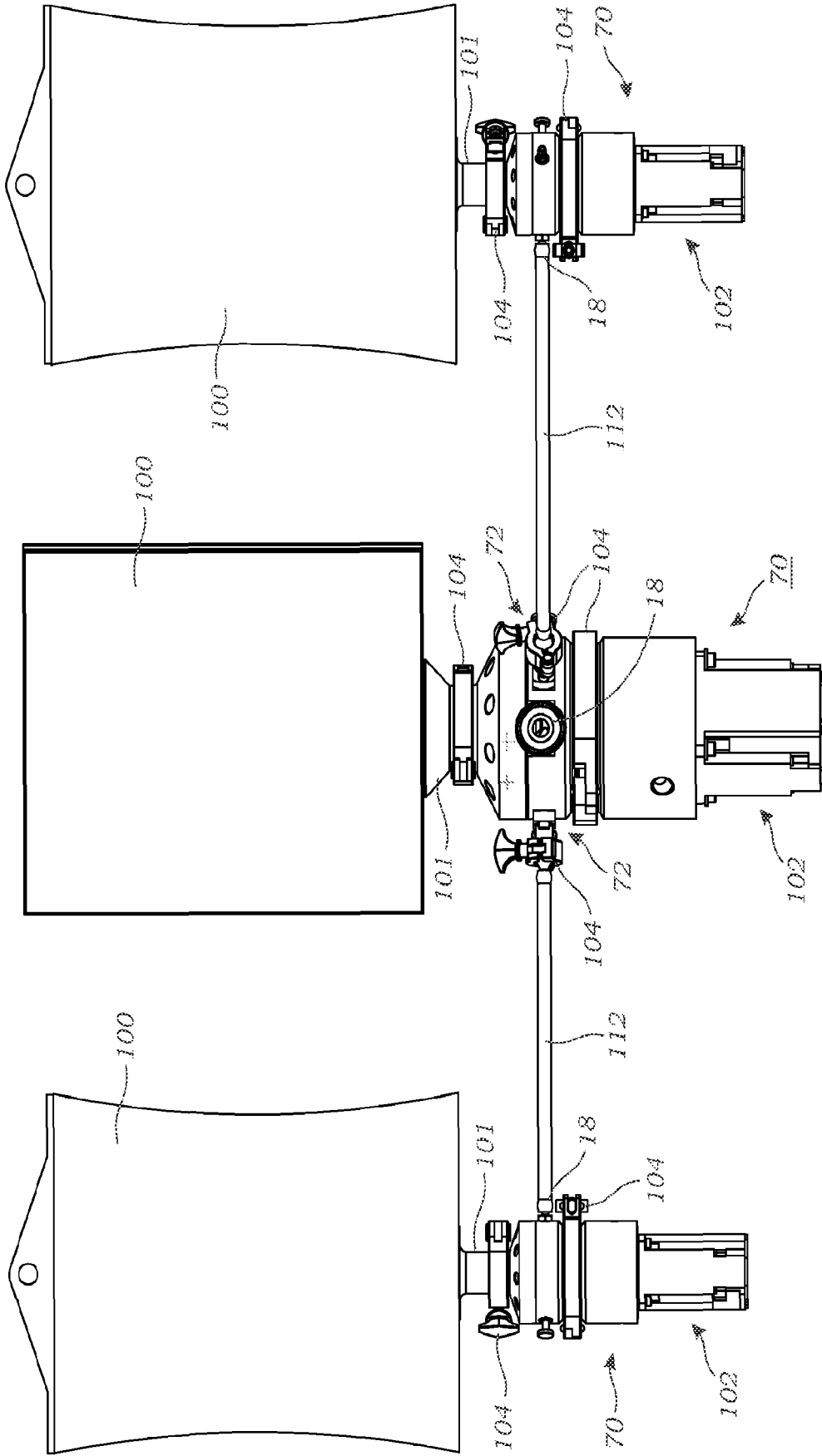

FIG. 14

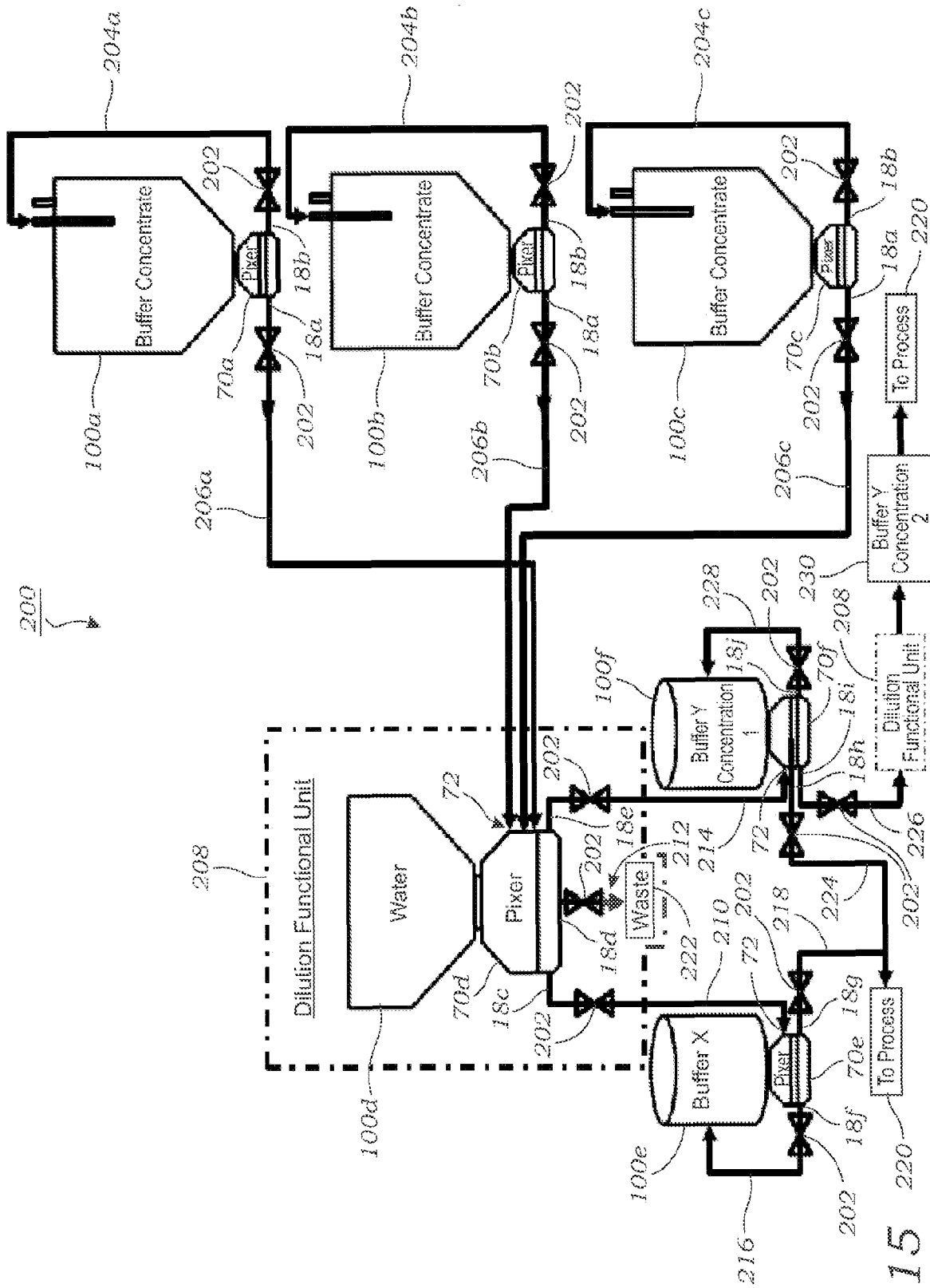

FIG. 15

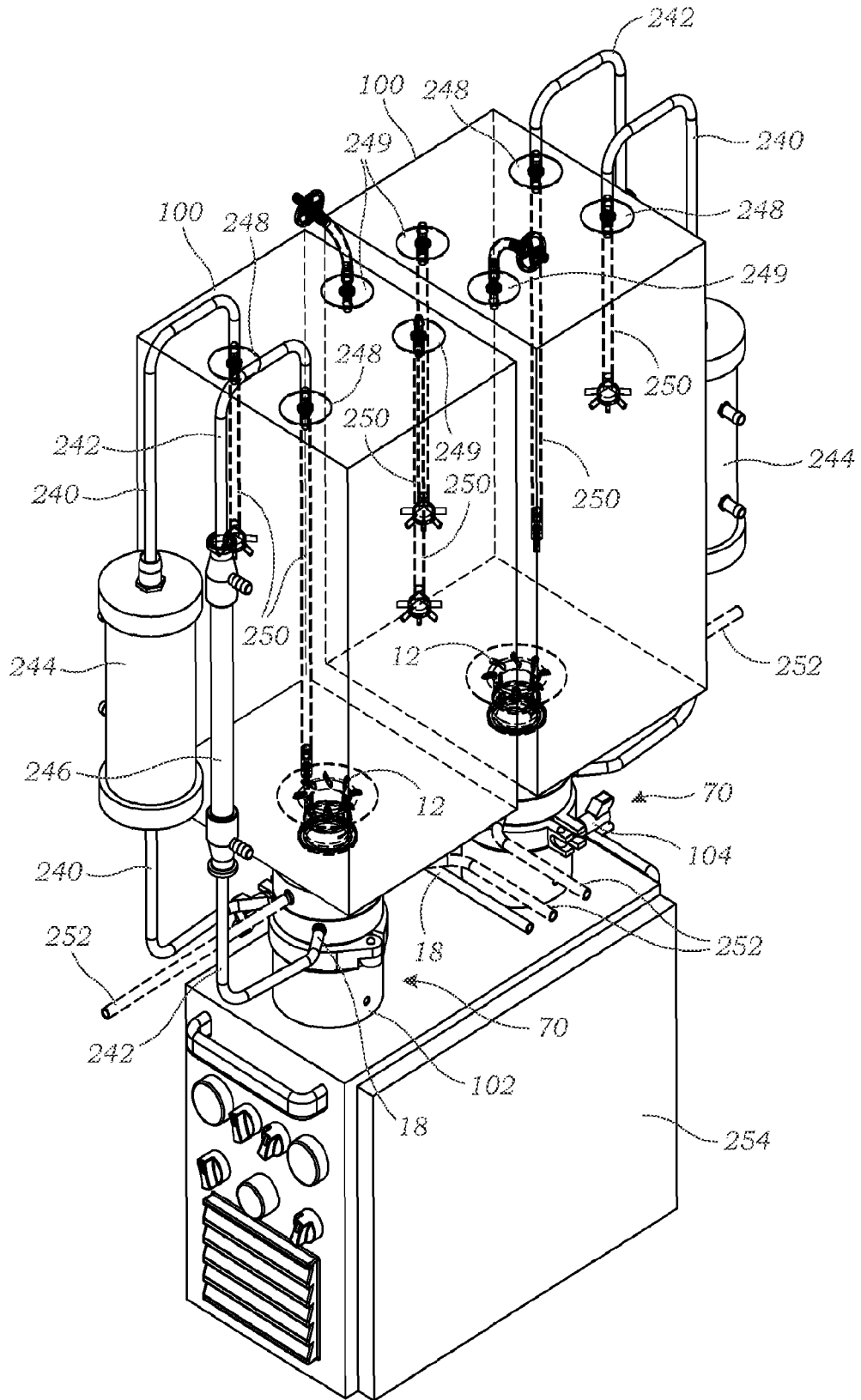

FIG. 16A

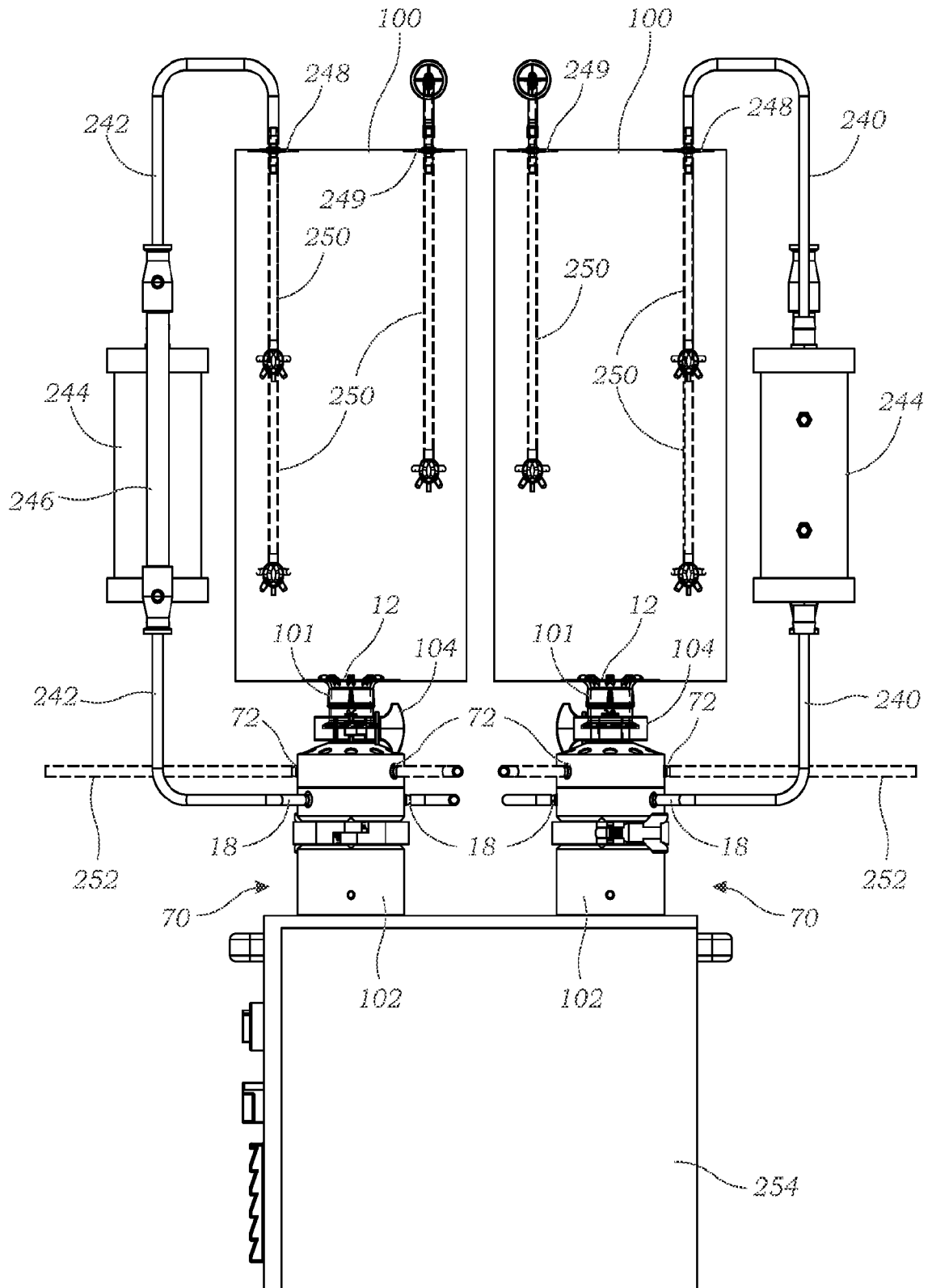

FIG. 16B

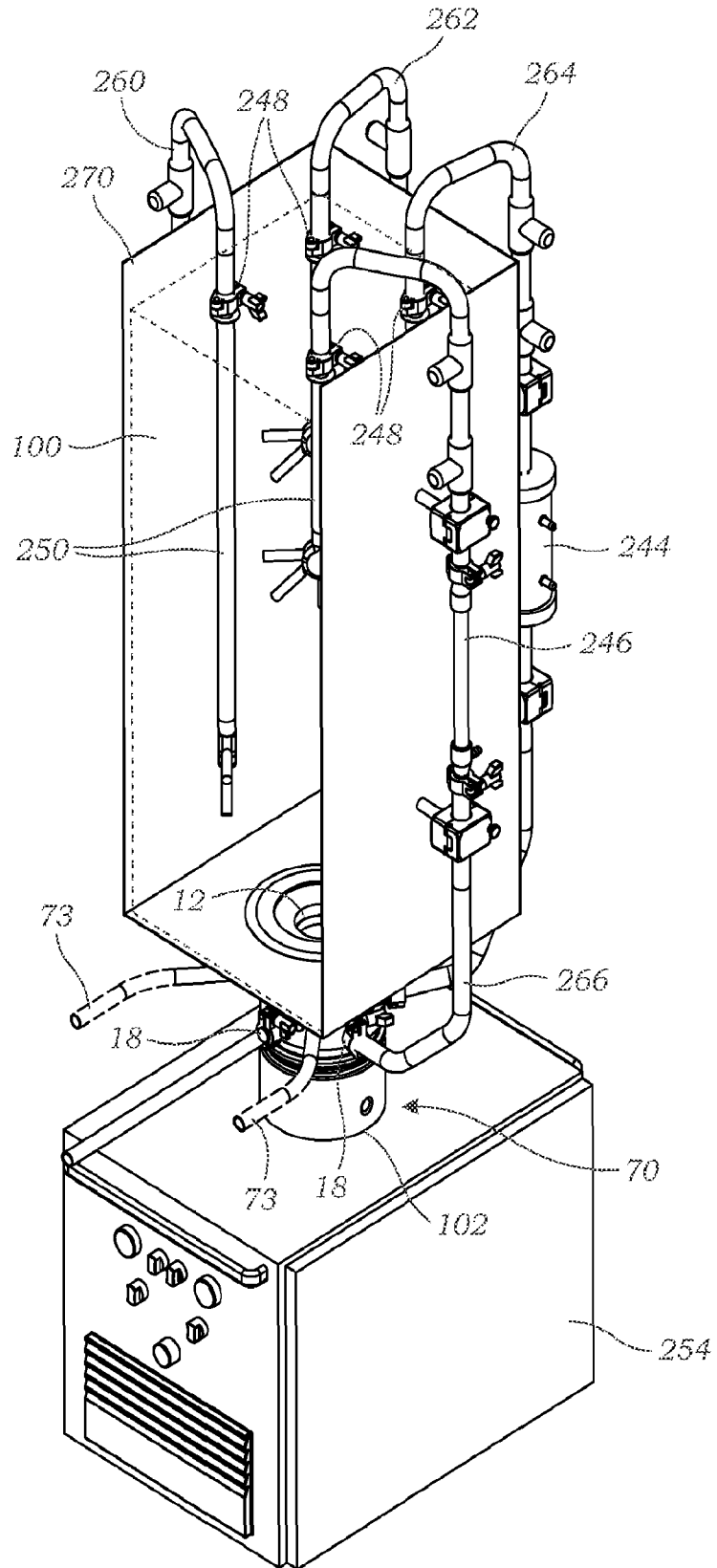

FIG. 17A

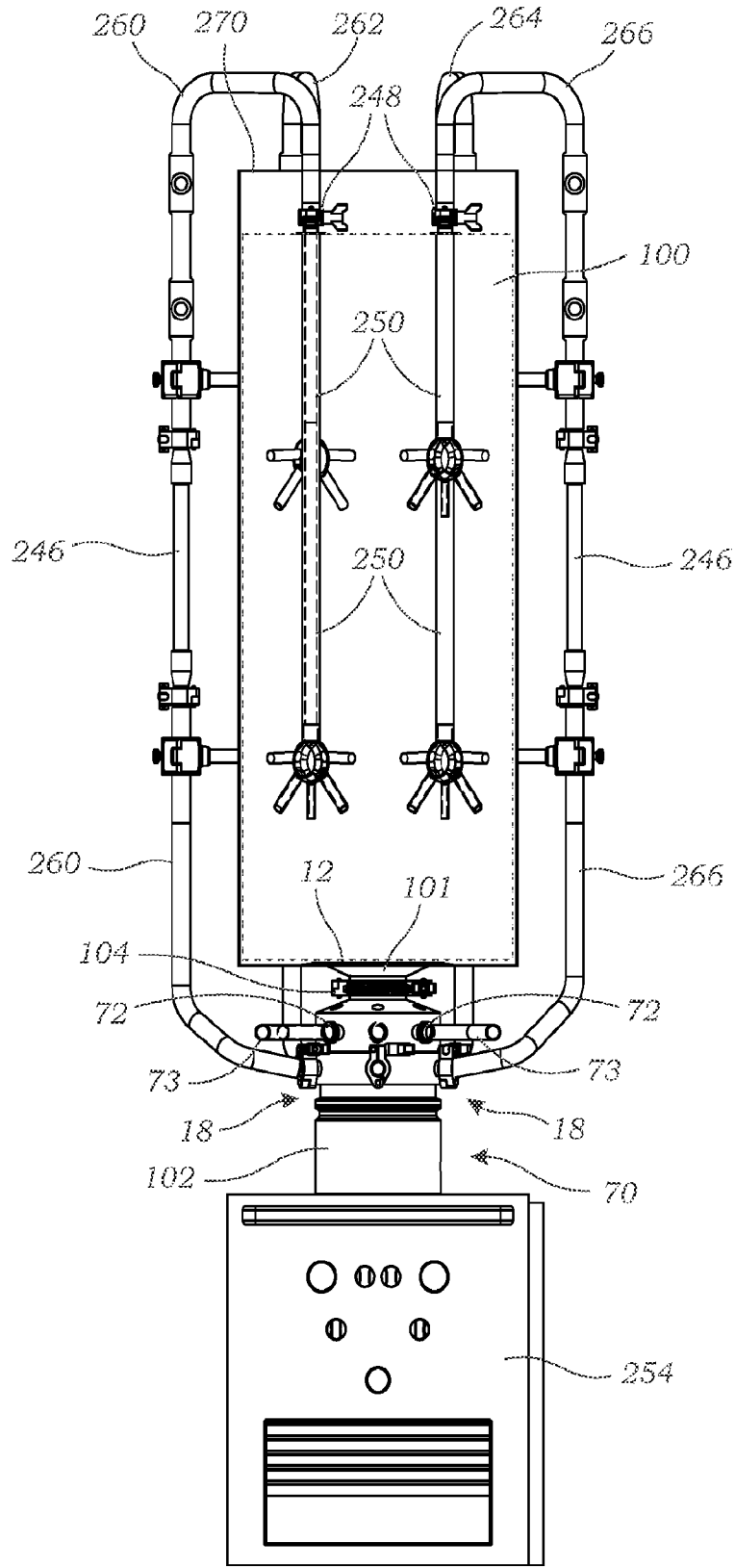

FIG. 17B

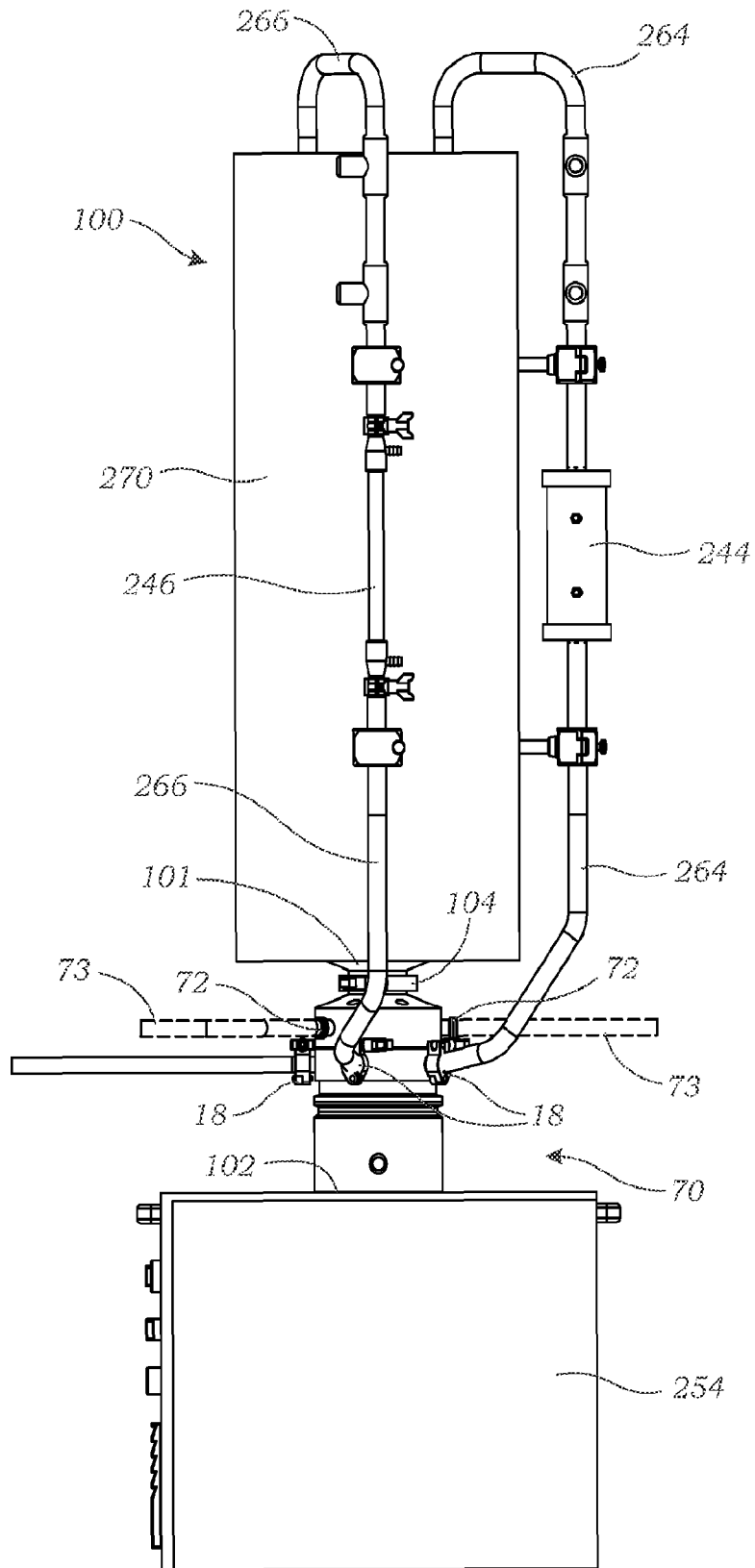

FIG. 17C