



(11) (21) (C) **2,205,669**
(22) 1997/06/19
(43) 1997/07/19
(45) 2000/05/16

(72) POIRIER, Paul W., CA

(73) VIEW GUARD INTERNATIONAL INC., CA

(51) Int.Cl.⁶ E06B 5/11, E06B 3/30

(54) **METHODE ET APPAREIL UTILISES POUR INSTALLER UNE
PELLICULE DE SECURITE POUR FENETRE SUR LE
POURTOUR D'UN CADRE DE FENETRE**

(54) **METHOD AND APPARATUS FOR EDGE MOUNTING
SECURITY WINDOW FILM IN A WINDOW FRAME**

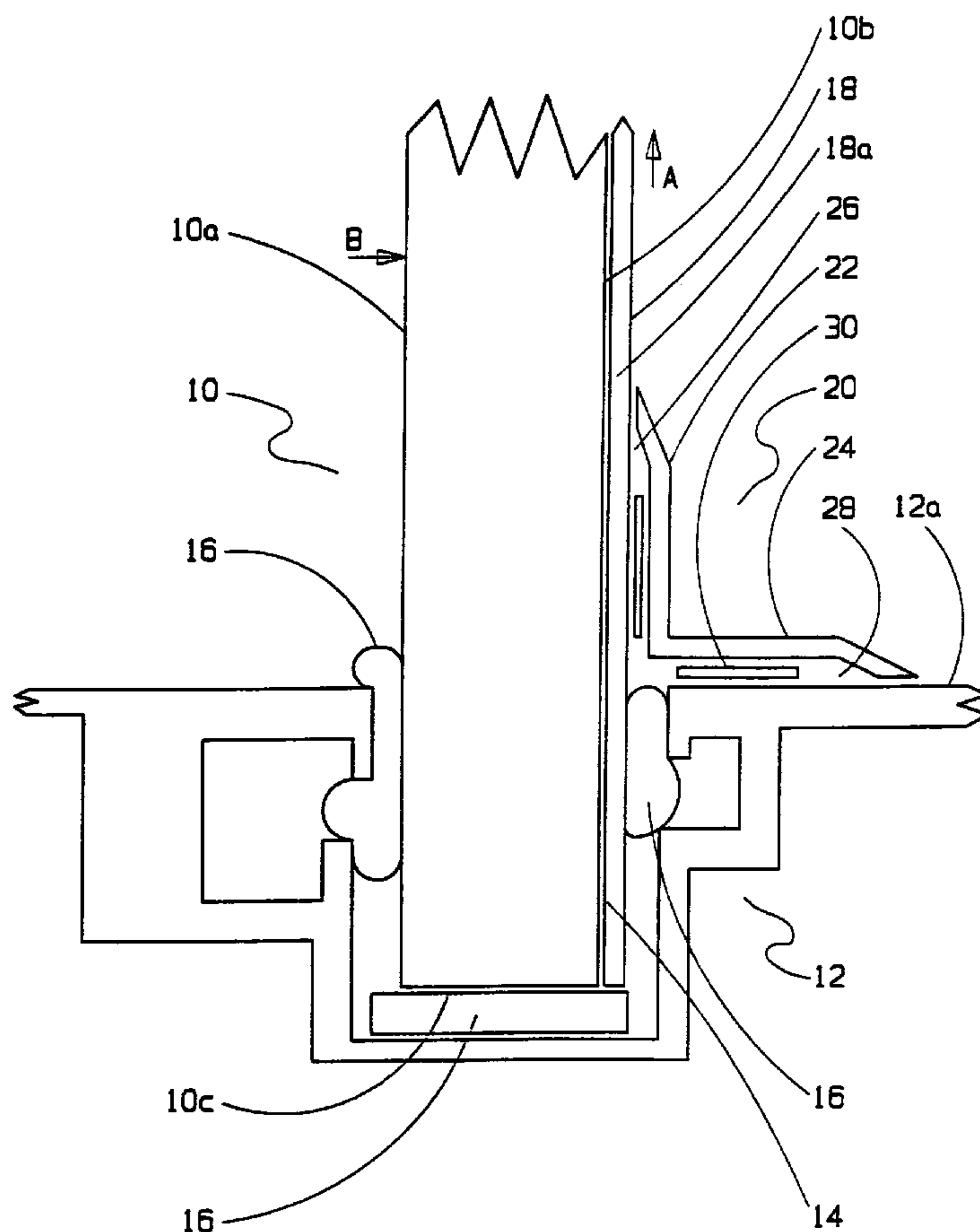

(57) Appareil utilisé pour installer une pellicule de sécurité pour fenêtre sur un cadre de fenêtre. L'appareil comprend un élément allongé servant au transfert de la charge de traction et doté de deux bords porteurs allongés adjacents ayant chacun une face porteuse

(57) An apparatus for mounting security window film to a window frame, includes an elongate tensile loading transfer member having first and second adjacent elongate load bearing flanges and corresponding first and second respective elongate bearing surfaces thereon,





(11) (21) (C) **2,205,669**
(22) 1997/06/19
(43) 1997/07/19
(45) 2000/05/16

allongée, deux bandes allongées de ruban de mousse adhésive double face à installer sur la première face des bandes adhésives, le long de la première et de la deuxième faces porteuses. La première bande de ruban adhésif se pose sur la deuxième face porteuse, du côté opposé à la première face, sur le bord d'une pellicule de sécurité d'une épaisseur d'au moins 10 mil et collée sur la vitre d'une fenêtre. La deuxième bande se pose sur la deuxième face, du côté opposé à la première face, sur le bord de cadre de fenêtre adjacent à la pellicule de sécurité. Les bandes de ruban adhésif peuvent supporter une tension d'environ 225 lbs/po², lorsque cette tension est appliquée aux bandes et à la pellicule de sécurité, celle-ci étant fixée à l'élément de transfert de la charge de traction par la première bande adhésive, et lorsque la tension est appliquée au cadre de fenêtre, celui-ci étant fixé à l'élément de transfert de la charge de traction par la deuxième bande adhésive.

first and second elongate double sided foam adhesive tape strips mountable, on first sides of the adhesive tape strips, along respective the first and second bearing surfaces, the first adhesive tape strip mountable on its second side, opposite to the first side, to an edge of a sheet of security window film having a thickness of at least 10 mil adhered to a glass window pane, the second adhesive tape strip mountable on its second side, opposite to the first side, to an edge of a window frame adjacent the edge of sheet of security window film, wherein, the first and second adhesive tape strips are adapted to bear approximately 225 lbs per square inch in tension applied to the first and second adhesive tape strips and to the security window film when adhesively mounted to the tensile load transfer member by the first adhesive tape strip and to the window frame when mounted to the tensile load transfer member by the second adhesive tape strip.



Abstract of the Disclosure

5 An apparatus for mounting security window film to a window frame, includes an elongate tensile loading transfer member having first and second adjacent elongate load bearing flanges and corresponding first and second respective elongate bearing surfaces thereon, first and second elongate double sided foam adhesive tape strips mountable, on first sides of the adhesive tape strips, along respective the first and second bearing surfaces, the first adhesive tape strip mountable on its second side, opposite to the first side, to an edge of a sheet of security window film having a thickness of at least 10 mil adhered to a glass window pane, the second adhesive tape strip mountable on its second side, opposite to the first side, to an edge of a window frame adjacent the edge of sheet of security window film, wherein, the first and second adhesive tape strips are adapted to bear approximately 225 lbs per square inch in tension applied to the first and second adhesive tape strips and to the security window film when adhesively mounted to the tensile load transfer member by the first adhesive tape strip and to the window frame when mounted to the tensile load transfer member by the second adhesive tape strip.

10

15

METHOD AND APPARATUS FOR EDGE MOUNTING
SECURITY WINDOW FILM IN A WINDOW FRAME

Field of the Invention

5

This invention relates to the field of security window film and its application to glass windows, and, in particular, to a method and apparatus for edge mounting security window film in a window frame.

10

Background of the Invention

15

Break and entry crimes are a well documented and, apparently, daily occurrence in many, if not all, cities. Break and entry into commercial retail establishments is a particularly vexing problem in that, on the one hand, it is desirable for the retail establishment to have large attractive displays of their wares behind panoramic glass windows so as to advertise and promote the establishment's wares, and on the other hand, such large windows and their associated displays of wares, provide an enticing target for the criminal element who count on being able to break the glass from the outside and grab the wares on display through the open window frame.

20

25

In the prior art, it is common, especially in high crime areas, for commercial retail outlets to have either permanently installed metal bars either in front of or behind the glass storefront displays, thereby, marring the attractiveness of the display, or to have pull down shutters or grates so as to lock an obstacle into place between the glass windows and a person attempting to break and enter. Both of these prior art solutions are not only unsightly, but expensive to install and, in the latter case, unreliable to maintain, in that employees must be relied on to lower and lock into place the shutters or grates.

So called security film has become available more recently to address the problem of break and enter through glass windows. Security film is typically a thin, transparent, polymer film providing a resilient high tensile strength barrier which, when adhered against an interior surface of a glass window, resists complete shattering of the glass when an attempt at penetration is made from the outside. One commercial supplier of security window film are Metallized Products in St. Petersburg, Florida, U.S.A., who supply 12 mil and 14 mil cross weaved polyester film under the trademark Sun-gard. Another supplier of security window film is 3M™ who market safety and security film under the trademark Scotchshield. Scotchshield™ is held out by 3M™ as resisting penetration by keeping the glass in place during attempted break-ins, storms and earthquakes.

However, it is the applicant's experience that merely applying security window film is not sufficient in many instances to prohibit break and enter. In particular, it is quite often the case that a glass window, whether it has security film applied or whether it has embedded wire mesh or the like, will not prevent a break and enter at the hands of a determined assailant because the edges of the glass window are typically not secured to the window frame. Consequently, to affect a break and enter, the glass window, held together by its embedded wire mesh or security window film applied to an inner surface, merely has to be broken and bowed sufficiently to draw the edges of the glass free of the window frame, at which point the entire window may be pushed free of the frame.

In the prior art an attempt to overcome this problem has been made by an entity doing business under the trademark Glasslock in San Jose, California, U.S.A. The Glasslock™ solution is to extend the edge of security window film beyond the edge of the glass so as to overlap a significant portion of the window frame with security window film. Rigid base plates are then overlaid over the overlapping area. The rigid base plates are screwed into the window frame so as to sandwich the edges of the window security film between the rigid base plate and the window frame. In this fashion, when bowing of the broken glass tensions the film, the tension

is resisted by the mechanical mounting of the edges of the window security film to the window frame. In particular, the Glasslock™ device is typically employed to bend the edges of the security window film at 90 degrees to the plane of the window so that the mechanical mounting of the film to the window frame by means of screws through the rigid base plate is assisted by bending of the film around an edge of the plate adjacent the window.

Applicant has determined that it is unnecessary and likely counter-productive to perforate the security window film by screws or the like extending through rigid plates. It is, further, unnecessary to bend the film over the edge of the rigid base plate as a means of applying the tensile load from the film to the rigid base plate, although it does help prevent the film merely tearing free of the mounting screws due to the stress concentrations around the holes punctured in the film by the mounting screws.

It is an object of the present invention to provide an adhesive based method and apparatus for adhesively mounting the edge of security window film to a window frame so as to offer tensile resistance to bowing of the glass once broken, so that the same or better result is achieved as compared with the more difficult to install mechanical Glasslock™ device which requires a significant window frame depth, and requires drilling and screwing of a rigid base plate to the window frame. It is a further object to provide for adhesively mounting the edge of security window film to the edge of the glass window pane.

Summary of the Invention

Applicant's invention resides in the applicant's discovery that certain commercially available double sided very high bond (VHB) tape, such as that available commercially from 3M™ Industrial Specialties Division of St. Paul, Minnesota, U.S.A., under the trademark Scotch VHB and in particular, models #4925 and #4945 doubled coated acrylic foam tape, in combination with a thin metal tensile loading transfer strip, resulted, unexpectedly, in significant

resistance to bowing of broken glass within a window frame. Applicant has determined that VHB 4945 double sided adhesive tape when used in the method and apparatus of the present invention, resists straight pull tension of approximately 1,000 pounds per square inch on security window film. Applicant has determined that if lesser security applications are required, for example, requiring approximately 225 pounds per square inch, resistance to straight pull tension on the security window film, VHB 4925 double sided adhesive tape may be employed.

Thus, as described herein and as may be seen in the accompanying drawings, the present invention is one of attractive simplicity. In addition, the present invention is well adapted to retrofitting security window film onto existing glass windows.

In summary, the apparatus of the present invention for mounting security window film to a window frame comprises:

an elongate tensile loading transfer member having first and second adjacent elongate load bearing flanges and corresponding first and second respective elongate bearing surfaces thereon,

in one embodiment, first and second elongate double sided foam adhesive tape strips mountable, on first sides of said adhesive tape strips, along respective said first and second bearing surfaces,

said first adhesive tape strip mountable on its second side, opposite to said first side, to an edge of a sheet of security window film having a thickness of at least 10 mil adhered to a glass window pane,

said second adhesive tape strip mountable on its second side, opposite to said first side, to an edge of a window frame adjacent said edge of sheet of security window film,

wherein, in a first aspect of the invention, said first and second adhesive tape strips are adapted to bear approximately 225 lbs per square inch in tension applied to said tape strips and to said security window film when adhesively mounted to said tensile load transfer member by said first adhesive tape strip and to said window frame when mounted to said tensile load transfer member by said second adhesive tape strip.

In a second aspect of the invention, said first and second adhesive tape strips are adapted to bear approximately 1000 lbs per square inch in tension applied to said tape strips and to said security window film when adhesively mounted to said tensile load transfer member by said first adhesive tape strip and to said window frame when mounted to said tensile load transfer member by said second adhesive tape strip.

In a further aspect, said tensile load transfer member is a metal strip shaped to conform to the intersection between said edge of said sheet of security window film and said edge of said window frame adjacent said edge of said sheet of security window film, and said first and second flanges extend over said edge of said sheet of security window film and said window frame respectively so as to sandwich said first and second adhesive tape strips respectively between said flanges and said security window film.

In a second embodiment, said first adhesive tape strip is mountable to said first bearing surface, and said second load bearing flange is formed as a lip relative to said first load bearing flange for mounting said lip over an edge of said window pane so as to extend said first load bearing flange inwardly over said window pane, from said edge of said window pane, and over said edge of said sheet of security window film to thereby sandwich said first adhesive tape strip between said first load bearing flange and said edge of said sheet of security window film.

In the method of the present invention, a first method of mounting security window film to a window frame using an elongate tensile loading transfer member having first and second

adjacent elongate load bearing flanges and corresponding first and second respective elongate bearing surfaces thereon, first and second elongate double sided foam adhesive tape strips mountable, on first sides of said adhesive tape strips, along respective said first and second bearing surfaces, said first adhesive tape strip mountable on its second side, opposite to said first side, to an edge of a sheet of security window film having a thickness of at least 10 mil adhered to a glass window pane, said second adhesive tape strip mountable on its second side, opposite to said first side, to an edge of a window frame adjacent said edge of sheet of security window film, wherein said first and second adhesive tape strips are adapted to bear 225 lbs per square inch in tension applied to said tape strips and to said security window film when adhesively mounted to said tensile load transfer member by said first adhesive tape strip and to said window frame when mounted to said tensile load transfer member by said second adhesive tape strip, comprises the steps of:

- (a) cutting said sheet of security window film sized to fit from edge to edge across said window pane when adhered thereto,
- (b) adhering said sheet of security window film to said window pane from edge to edge and allowing to cure,
- (c) selecting, or shaping, said tensile load transfer member of, or to, a shape wherein said tensile load transfer member is shaped to conform to the intersection between said edge of said sheet of security window film and said edge of said window frame adjacent said edge of said sheet of security window film, and said first and second flanges extend over said edge of said sheet of security window film and said window frame respectively so as to sandwich said first and second adhesive tape strips respectively between said flanges and said security window film,

(d) applying said first and second adhesive tape strips to said first and second flanges respectively,

5 (e) applying said load transfer member to said sheet of security window film and said window frame so that said first and second flanges extend over said edge of said sheet of security window film and said window frame respectively and so as to sandwich said first and second adhesive tape strips respectively between said flanges and said security window film.

10 In a second method of the present invention, a method of mounting security window film to a window frame using an elongate tensile loading transfer member having first and second adjacent elongate load bearing flanges and corresponding first and second respective elongate bearing surfaces thereon, a first elongate double sided foam adhesive tape strip mountable, on a first side of said adhesive tape strip, along said first bearing surfaces, said first
15 adhesive tape strip mountable on its second side, opposite to said first side, to an edge of a sheet of security window film having a thickness of at least 10 mil adhered to a glass window pane, wherein said first adhesive tape strip is adapted to bear 225 lbs per square inch in tension applied to said tape strip and to said security window film when adhesively mounted to said tensile load transfer member by said first adhesive tape strip, wherein said second load bearing flange is a lip
20 for mounting over an edge of said glass window pane so as to extend said first load bearing flange inwardly over said window pane, from said edge of said window pane, and over said edge of said sheet of security window film to thereby sandwich said first adhesive tape strip between said first load bearing flange and said edge of said sheet of security window film, comprising the steps of:

25 (a) cutting said sheet of security window film sized to fit from edge to edge across said window pane when adhered thereto,

- (b) adhering said sheet of security window film to said window pane from edge to edge and allowing to cure,
- (c) selecting, or shaping, said tensile load transfer member of, or to, a shape wherein said tensile load transfer member is shaped to conform to said edge of said glass window pane generally adjacent the intersection between said edge of said sheet of security window film and said edge of said window frame adjacent said edge of said sheet of security window film, and said first flange extends over said edge of said sheet of security window film so as to sandwich said first adhesive tape strip between said flange and said security window film,
- (d) applying said first adhesive tape strip to said first flange,
- (e) applying said load transfer member to said sheet of security window film and said glass window pane so that said first flange extends over said edge of said sheet of security window film and said glass window pane and so as to sandwich said first adhesive tape strip between said flange and said security window film.

Brief Description of the Drawings

Figure 1 is, in an enlarged partially broken away cross-sectional view, the adhesive edge mounting of a security window film to a window frame of the present invention.

Figure 2 and Figure 3 are, alternative embodiments of the edge mounting of window security film to a window frame of the present invention.

Figure 4 is, in an enlarged partially broken away cross-sectional view, the adhesive edge mounting of a security window film to an edge of a window pane of the present invention.

5 Figure 4a is, in perspective view, a prior art window frame having a glass pane conventionally mounted therein.

Figure 4b is, in perspective view, the window frame of Figure 4a being modified according to the method of one embodiment of the present invention.

10 Figure 4c is, in perspective view, the window frame of Figure 4a with one embodiment of the apparatus for edge mounting security window film of the present invention retrofitted thereto.

Detailed Description of the Preferred Embodiment

15 As may be seen in Figure 1, in a typical arrangement, glass window pane 10 is mounted within window frame 12 within channel 14 and secured between resilient gaskets 16. Glass window pane 10 has outwardly facing exterior surface 10a and inwardly facing interior surface 10b.

20 Security window film 18, which advantageously may be 12 mil or 14 mil cross weaved polyester film is cut to the size of the exposed or exposable area of window frame 12 and mounted thereto by methods well known in the art.

25 An appropriately shaped tensile loading transfer strip 20 is selected depending on the manner in which the edge portion 18a of security window film 18 is to be adhesively mounted and secured to either interior surface 12a of window frame 12 or edge 10c of glass window pane 10.

In the embodiment illustrated in Figure 1, tensile loading transfer strip 20 is, in cross section, bent at 90 degrees so that first bearing flange 22 is at right angles to second bearing flange 24. The distal ends of first and second bearing flanges 22 and 24 are bent so as to form cavities 26 and 28 between, respectively, first and second bearing flanges 22 and 24 when tensile loading transfer strip 20 is mounted as illustrated into the intersection between security window film 18, at edge portion of 18a, and window frame 12 at interior surface 12a. Cavities 26 and 28 are sized to respectively accommodate snugly therein corresponding strips of double sided adhesive tape 30 such as VHB 4925 double sided foam tape for low security applications and VHB 4945 double sided foam tape for high security applications.

Double sided tape strips 30 provide resilient adhesive bonding between edge portion 18a and first bearing flange 22 and between interior surface 12a and second bearing flange 24. Once adhered, double sided tape strips 30 act to transfer a tensile load in direction A on security window film 18 such as would occur if glass window pane 10 was broken inwardly in direction B, and transfers the tensile load via double sided tape strips 30 and tensile loading transfer strip 20 to interior surface 12a and window frame 12.

Tensile loading transfer strip 20 is preferably a metal strip advantageously according to the following specifications:

Galvanized	Carbon manganese
CQ	Commercial Quality
ASTM	A526 R-A653 (m)
SAE	1006-1012
Chemical Composition % Max	C.0.15 Mn 0.60

Yield Strength	PSI	35,000 - 45,000		
	MPA	240 - 310		
Melt (HEAT)		800° F		
Paint Coating (Melt)		350° - 400° F		
5	mm	(IN)	mm	IN
Thickness	0.38	0.015	4.27	0.166
Elongation in 50 mm (2 inches) %		32 - 42 mm.		

10 Of course, it may be that other high tensile strength strips may also function so long as double sided tape strips 30 may be strongly adhered to them and there are sufficiently strong to transfer a tensile load in direction A to window frame 18.

15 In the embodiments illustrated in Figures 2 and 3, tensile loading transfer strips 20 are shaped so as to accommodate differently shaped and sized mullions 32 on the interior of window frame 12.

20 In Figure 2, tensile loading transfer strip 20 is generally planar with second bearing flange 24 being offset from first bearing flange 22 by generally the thickness of mullion 32. The end result is the same as the embodiment of Figure 1 wherein a tensile load applied in direction A to security window film 18 is transferred to window frame 12 via double sided tape strips 30, tensile loading transfer strip 20 and mullion 32. In Figure 3, transfer of the tensile load does not include transfer of the load through mullion 32 in that tensile loading transfer strip 20 is shaped to fit over mullion 32 so that first and second bearing flanges 22 and 24 extend outwardly on either side of mullion 32. In this fashion, the tensile load is transferred between security window film
25 18 and interior surface 12a of window frame 12 directly between double sided tape strips 30 via tensile loading transfer strip 20 only.

In the embodiment illustrated in Figure 4, tensile loading transfer strip 20 secures security window film 18 at edge portion 18a to edge 10c of glass window pane 10 rather than window frame 12. In particular, rather than first and second bearing flanges 22 and 24 being bent at 90 degrees with respect to each other so as to direct second bearing flange 24 outwardly of glass window pane 10 and over interior surface 12a of window frame 12, second bearing flange 24 is bent inwardly at 90 degrees to first bearing flange 22 so as to form a lip which may be hooked behind glass window pane 10 residing in channel 14 so as to extend second bearing flange 24 at least partially over edge 10c. In this embodiment, only one double sided tape strip 30 is required, namely, between edge portion 18a of security window film 18 and first bearing flange 22.

Illustrated in Figure 4 in dotted outline is stop 34 and resilient gasket or wedge 36. In this embodiment, when installing security window film 18, stop 34 and the associated gasket is first removed so as to expose more of interior surface 10b. Tensile loading transfer strip 20 and its associated double sided tape strip 30 is then installed over edge portion 18a. Stop 34 is then reinstalled and a resilient gasket or wedge 36, for example, having a thickness of 0.090 inches, inserted between first bearing flange 22 and stop 34.

As will be apparent to those skilled in the art in the light of the foregoing disclosure, many alterations and modifications are possible in the practice of this invention without departing from the spirit or scope thereof. Accordingly, the scope of the invention is to be construed in accordance with the substance defined by the following claims.

WHAT IS CLAIMED IS:

1. An apparatus for mounting security window film by adhesion to a window frame for resisting high tensile loads applied to said window film when said window film is adhered to a glass pane mounted in said window frame, comprising;

an elongate tensile loading transfer member having first and second adjacent elongate load bearing flanges and corresponding first and second respective elongate bearing surfaces thereon, wherein said elongate tensile loading transfer member is not adapted for mechanical fastening to said frame but rather is only adapted for adhesive fastening to said frame,

first and second elongate double sided foam adhesive tape strips mountable, on first sides of said adhesive tape strips, along respective said first and second bearing surfaces,

said first adhesive tape strip mountable on its second side, opposite to said first side, to an edge of a sheet of security window film having a thickness of at least 10 mil adhered to said glass window pane,

said second adhesive tape strip mountable on its second side, opposite to said first side, to an edge of a window frame adjacent said edge of sheet of security window film,

wherein, said first and second adhesive tape strips are adapted to bear approximately 225 lbs per square inch in tension applied to said first and second adhesive tape strips and to said security window film when adhesively mounted to said tensile load transfer member by said first adhesive tape strip and to said window frame when mounted to said tensile load transfer member by said second adhesive tape strip.

2. The apparatus of claim 1 wherein said first and second adhesive tape strips are adapted to bear approximately 1000 lbs per square inch in tension applied to said tape strips and to said security window film when adhesively mounted to said tensile load transfer member by said first adhesive tape strip and to said window frame when mounted to said tensile load transfer member by said second adhesive tape strip.
3. The apparatus of claim 1 wherein said tensile load transfer member is a metal strip shaped to conform to an intersection between said edge of said sheet of security window film and said edge of said window frame adjacent said edge of said sheet of security window film, and said first and second flanges extend over said edge of said sheet of security window film and said window frame respectively so as to sandwich said first adhesive tape strip between said first flange and said security window film and so as to sandwich said second adhesive tape strip between said second flange and said window frame.
4. An apparatus for mounting security window film by adhesion within a window frame for resisting high tensile loads applied to said window film when said window film is adhered to a glass pane mounted in said window frame, comprising an elongate tensile loading transfer member having first and second adjacent elongate load bearing flanges and corresponding first and second respective elongate bearing surfaces thereon, wherein said elongate tensile loading transfer member is not adapted for mechanical fastening to said frame but rather is only adapted for adhesive fastening to said frame, a first adhesive tape strip mountable to said first bearing surface, said second load bearing flange formed as a lip relative to said first load bearing flange for mounting said lip over an edge of said window pane so as to extend said first load bearing flange inwardly over said window pane, from said edge of said window pane, and over said edge of said sheet of security window film to thereby sandwich said first adhesive tape strip between said first load bearing flange and said edge of said sheet of security window film, wherein said first adhesive tape strip is adapted to bear approximately 225 lbs per square inch in tension

applied to said first adhesive tape strip and to said security window film when adhesively mounted to said tensile load transfer member by said first adhesive tape strip.

5. The apparatus of claim 4 wherein said first adhesive tape strip is adapted to bear
5 approximately 1000 lbs per square inch in tension.

6. A first method of mounting security window film by adhesion to a window frame for
resisting high tensile loads applied to said window film when said window film is adhered
to a glass pane mounted in said window frame, using an elongate tensile loading transfer
10 member having first and second adjacent elongate load bearing flanges and corresponding
first and second respective elongate bearing surfaces thereon, wherein said elongate tensile
loading transfer member is not adapted for mechanical fastening to said frame but rather is
only adapted for adhesive fastening to said frame, first and second elongate double sided
foam adhesive tape strips mountable, on first sides of said adhesive tape strips, along
15 respective said first and second bearing surfaces,

said first adhesive tape strip mountable on its second side, opposite to said first side, to an
edge of a sheet of security window film having a thickness of at least 10 mil adhered to
a glass window pane, said second adhesive tape strip mountable on its second side,
20 opposite to said first side, to an edge of a window frame adjacent said edge of sheet of
security window film, wherein said first and second adhesive tape strips are adapted to
bear 225 lbs per square inch in tension applied to said tape strips and to said security
window film when adhesively mounted to said tensile load transfer member by said first
adhesive tape strip and to said window frame when mounted to said tensile load transfer
25 member by said second adhesive tape strip, comprising the steps of:

(a) cutting said sheet of security window film sized to fit, when installed, so as to
extend between opposite edges of said window pane when adhered thereto,

- (b) adhering said sheet of security window film to said window pane between said opposite edges and allowing to cure,
- 5 (c) selecting a shape of said tensile load transfer member wherein said tensile load transfer member is shaped to conform to an intersection between said edge of said sheet of security window film and said edge of said window frame adjacent said edge of said sheet of security window film, and said first and second flanges extend over said edge of said sheet of security window film and said window frame respectively so as to sandwich said first and second adhesive tape strips respectively between said flanges and said security window film,
- 10 (d) applying said first and second adhesive tape strips to said first and second flanges respectively,
- 15 (e) applying said load transfer member to said sheet of security window film and said window frame so that said first and second flanges extend over said edge of said sheet of security window film and said window frame respectively and so as to sandwich said first and second adhesive tape strips respectively between said
- 20 flanges and said security window film.
7. A method of mounting security window film by adhesion to a window frame for resisting high tensile loads applied to said window film when said window film is adhered to a glass pane mounted in said window frame, using an elongate tensile loading transfer member
- 25 having first and second adjacent elongate load bearing flanges and corresponding first and second respective elongate bearing surfaces thereon, wherein said elongate tensile loading transfer member is not adapted for mechanical fastening to said frame but rather is only adapted for adhesive fastening to said frame, a first elongate double sided foam adhesive

tape strip mountable, on a first side of said adhesive tape strip, along said first bearing surfaces,

5 said first adhesive tape strip mountable on its second side, opposite to said first side, to an edge of a sheet of security window film having a thickness of at least 10 mil adhered to a glass window pane, wherein said first adhesive tape strip is adapted to bear 225 lbs per square inch in tension applied to said tape strip and to said security window film when adhesively mounted to said tensile load transfer member by said first adhesive tape strip, wherein said second load bearing flange is a lip for mounting over an edge of said glass
10 window pane so as to extend said first load bearing flange inwardly over said window pane, from said edge of said window pane, and over said edge of said sheet of security window film to thereby sandwich said first adhesive tape strip between said first load bearing flange and said edge of said sheet of security window film, comprising the steps of:

- 15
- (a) cutting said sheet of security window film sized to fit from an edge of said window pane to an opposite edge of said window pane across said window pane when adhered thereto,
 - 20 (b) adhering said sheet of security window film to said window pane from said edge to said opposite edge and allowing to cure,
 - (c) selecting a shape of said tensile load transfer member wherein said tensile load transfer member is shaped to conform to said edge of said glass window pane
25 generally adjacent the intersection between said edge of said sheet of security window film and said edge of said window frame adjacent said edge of said sheet of security window film, and said first flange extends over said edge of said sheet

of security window film so as to sandwich said first adhesive tape strip between said flange and said security window film,

(d) applying said first adhesive tape strip to said first flange,

5

(e) applying said load transfer member to said sheet of security window film and said glass window pane so that said first flange extends over said edge of said sheet of security window film and said glass window pane and so as to sandwich said first adhesive tape strip between said flange and said security window film.

10

8. A mounting device of a window security apparatus, the device mounting a security film to a window frame, the mounting device comprising;

15

an elongate tensile loading transfer member having first and second adjacent elongate load bearing flanges and corresponding first and second respective elongate bearing surfaces thereon,

20

first and second elongate double sided foam adhesive tape strips mountable, on first sides of said adhesive tape strips, along respective said first and second bearing surfaces,

25

said first adhesive tape strip mountable on its second side, opposite to said first side, to an edge of a sheet of security window film having a thickness of at least 10 mil adhered to a glass window pane,

said second adhesive tape strip mountable on its second side, opposite to said first side, to an edge of a window frame adjacent said edge of sheet of security window film,

wherein, said first and second adhesive tape strips are adapted to bear approximately 225 lbs per square inch in tension applied to said first and second adhesive tape strips and to said security window film when adhesively mounted to said tensile load transfer member by said first adhesive tape strip and to said window frame when mounted to said tensile load transfer member by said second adhesive tape strip,

and wherein said second elongate load bearing flange is bent along an edge thereof so as to form an adhesive tape strip receiving cavity for snugly receiving therein said second elongate double sided foam adhesive tape strip, said edge bent so as to be closely adjacent

said window frame when said tensile load transfer member is mounted to said window frame,

and wherein said tensile load transfer member is W-shaped in cross-section.

9. The apparatus of claim 8 wherein said first and second adhesive tape strips are adapted to bear approximately 1000 lbs per square inch in tension applied to said tape strips and to said security window film when adhesively mounted to said tensile load transfer member by said first adhesive tape strip and to said window frame when mounted to said tensile load transfer member by said second adhesive tape strip.

10. The apparatus of claim 8 wherein said tensile load transfer member is a metal strip shaped to conform to an intersection between said edge of said sheet of security window film and said edge of said window frame adjacent said edge of said sheet of security window film, and said first and second flanges extend over said edge of said sheet of security window film and said window frame respectively so as to sandwich said first adhesive tape strip between said first flange and said security window film, and so as to sandwich said second adhesive tape strip between said second flange and said window frame.

11. The apparatus of claim 3 wherein said tensile load transfer member is L-shaped in cross-section.
- 5 12. The apparatus of claim 3 wherein said tensile load transfer member is W-shaped in cross-section.
- 10 13. The apparatus of claim 10 wherein said tensile load transfer member is L-shaped in cross-section.
14. The apparatus of claim 10 wherein said tensile load transfer member is W-shaped in cross-section.
- 15 15. A window security apparatus for resisting high tensile loads applied to a window film when said window film is adhered to a glass pane mounted in a window frame, comprising in combination;
- 20 security window film adherable to said glass pane,
- an elongate tensile loading transfer member having first and second adjacent elongate load bearing flanges and corresponding first and second respective elongate bearing surfaces thereon,
- 25 first and second elongate double sided foam adhesive tape strips mountable, on first sides of said adhesive tape strips, along respective said first and second bearing surfaces,

said first adhesive tape strip mountable on its second side, opposite to said first side, to an edge of a sheet of said security window film having a thickness of at least 10 mil adhered to said glass window pane,

5 said second adhesive tape strip mountable on its second side, opposite to said first side, to an edge of said window frame adjacent said edge of said sheet of said security window film,

10 wherein, said first and second adhesive tape strips are adapted to bear approximately 225 lbs per square inch in tension applied to said first and second adhesive tape strips and to said security window film when adhesively mounted to said tensile load transfer member by said first adhesive tape strip and to said window frame when mounted to said tensile load transfer member by said second adhesive tape strip,

15 and wherein said second elongate load bearing flange is bent along an edge thereof so as to form an adhesive tape strip receiving cavity for snugly receiving therein said second elongate double sided foam adhesive tape strip, said edge bent so as to be closely adjacent said window frame when said tensile load transfer member is mounted to said window frame,

20 and wherein said tensile load transfer member is W-shaped in cross-section.

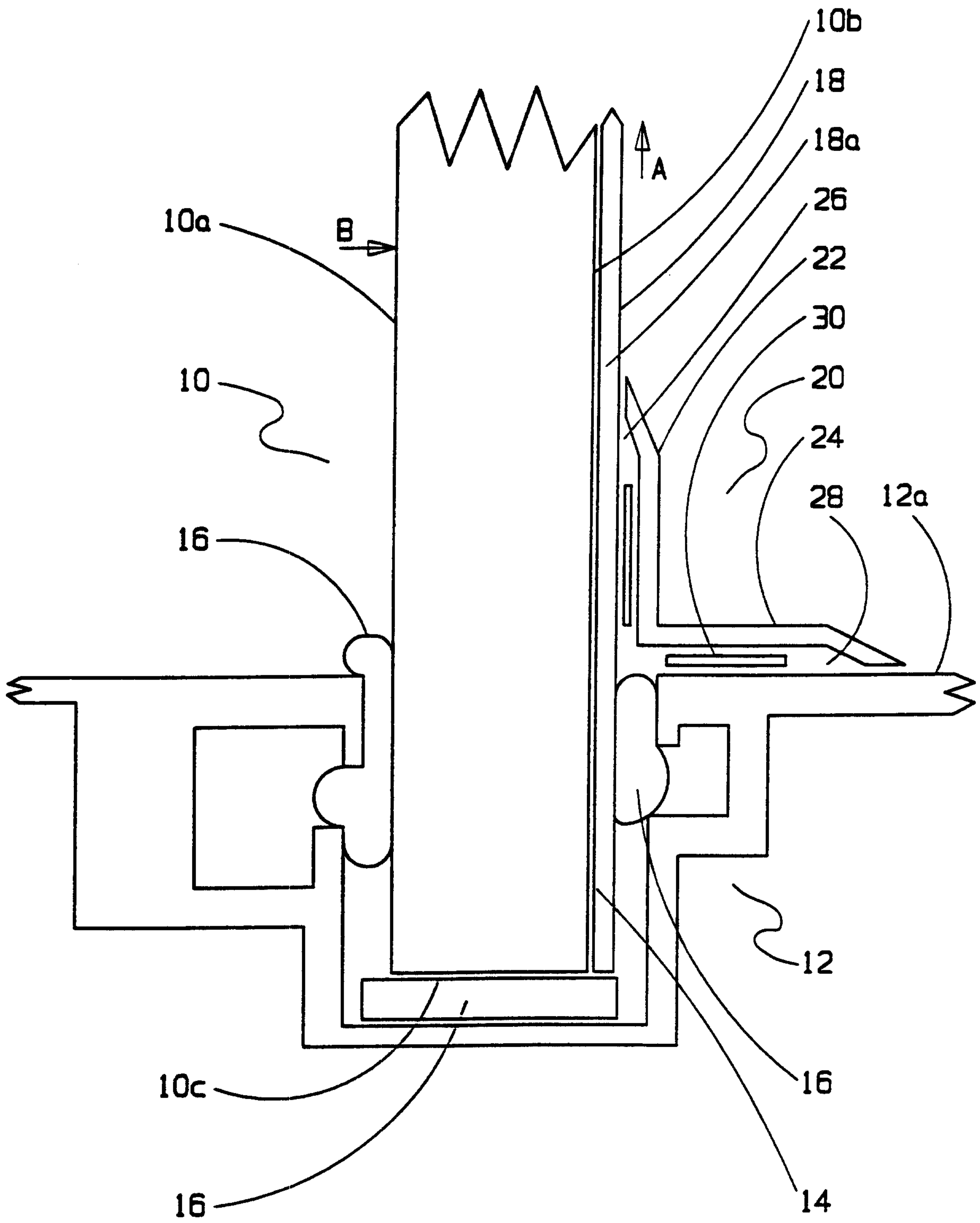

FIG. 1

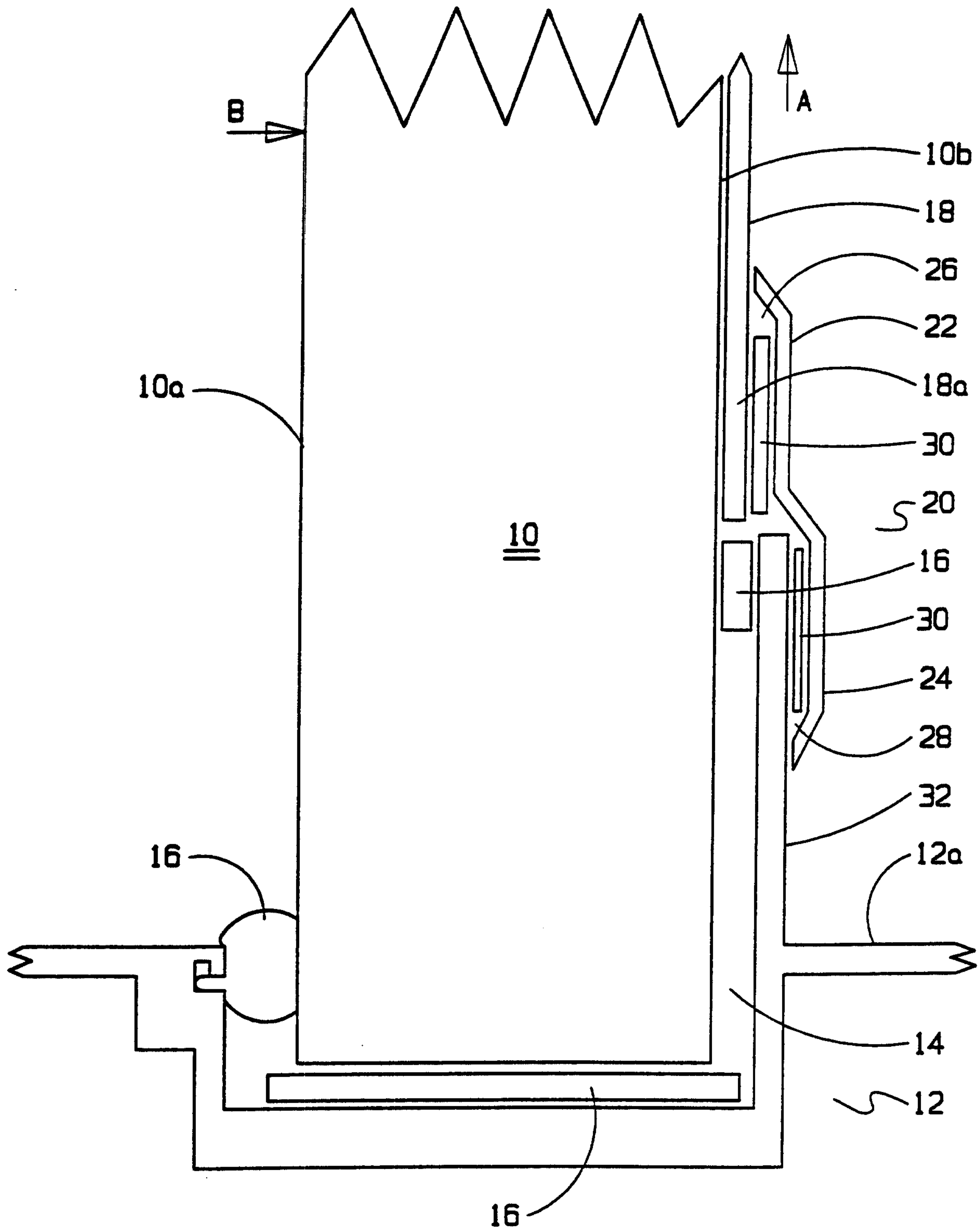

FIG. 2

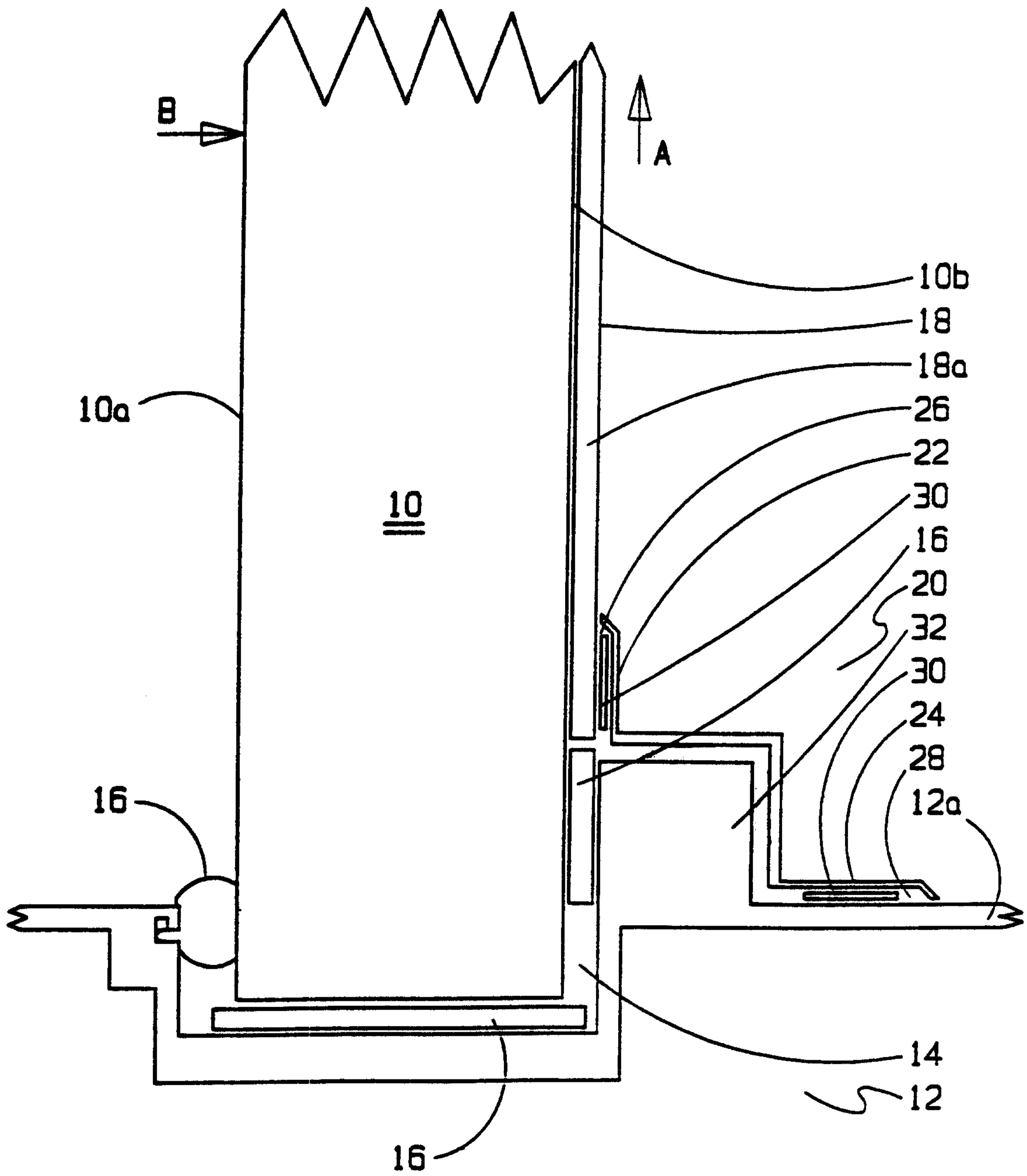

FIG. 3

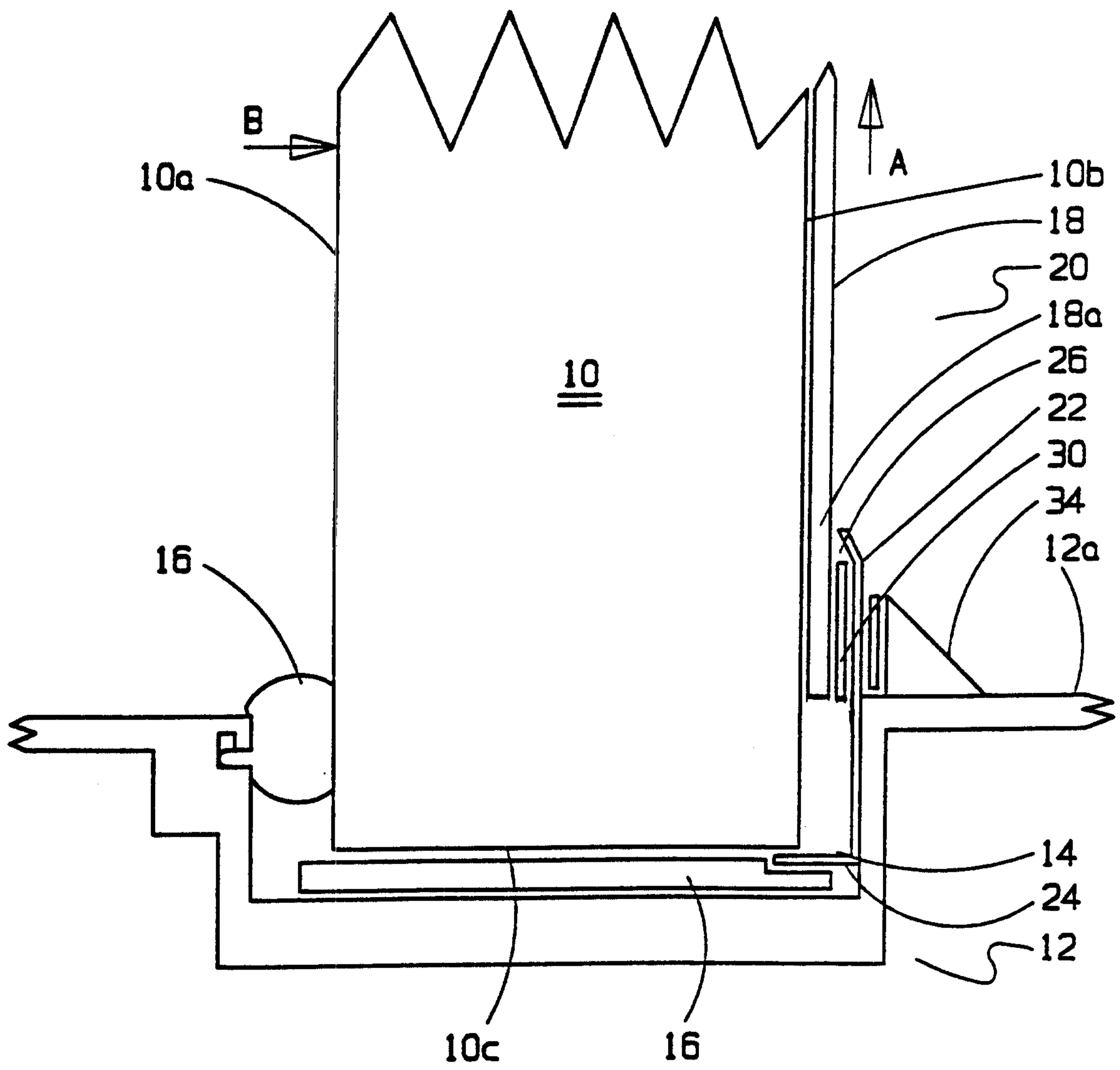

FIG. 4

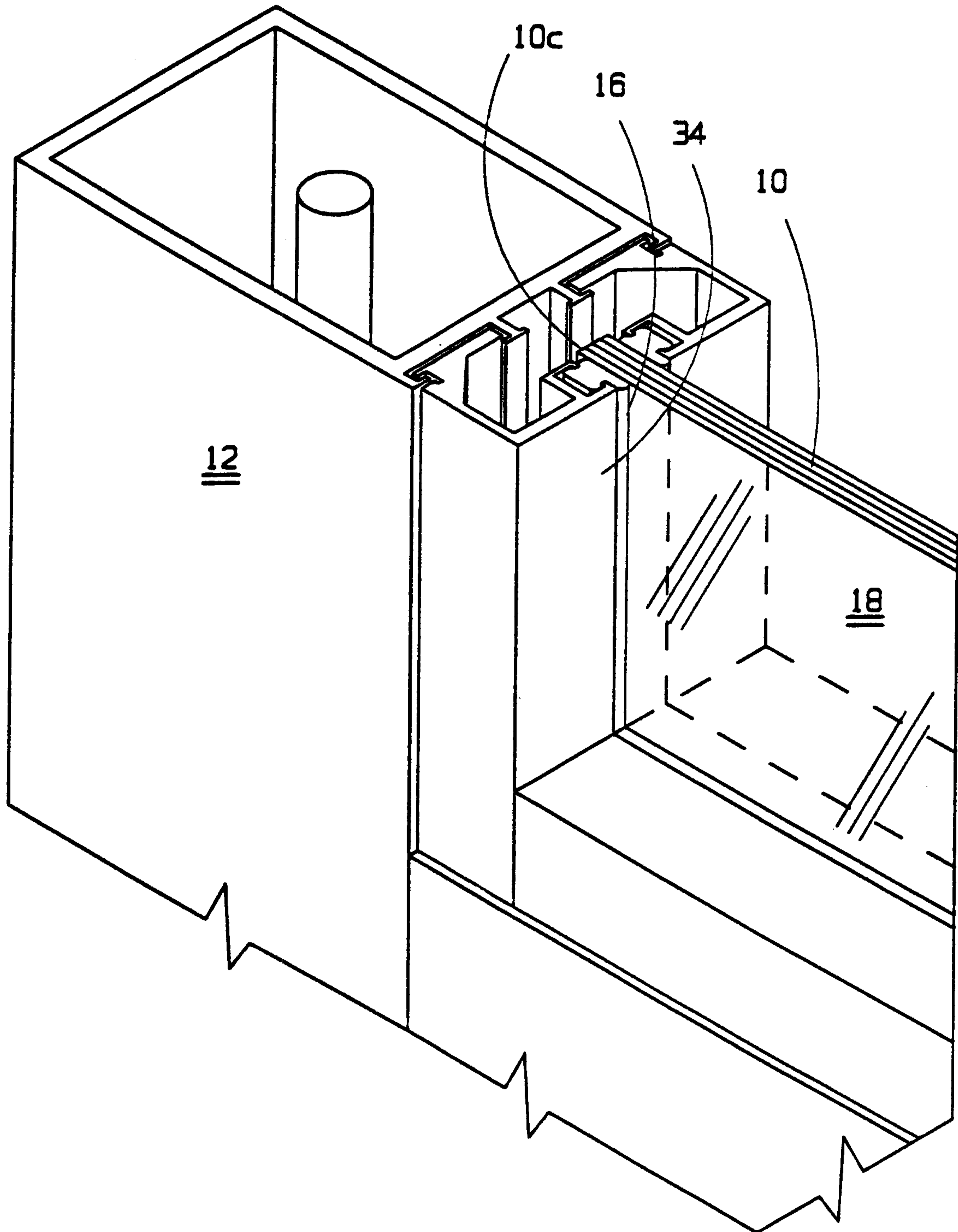

FIG. 4a
PRIOR ART

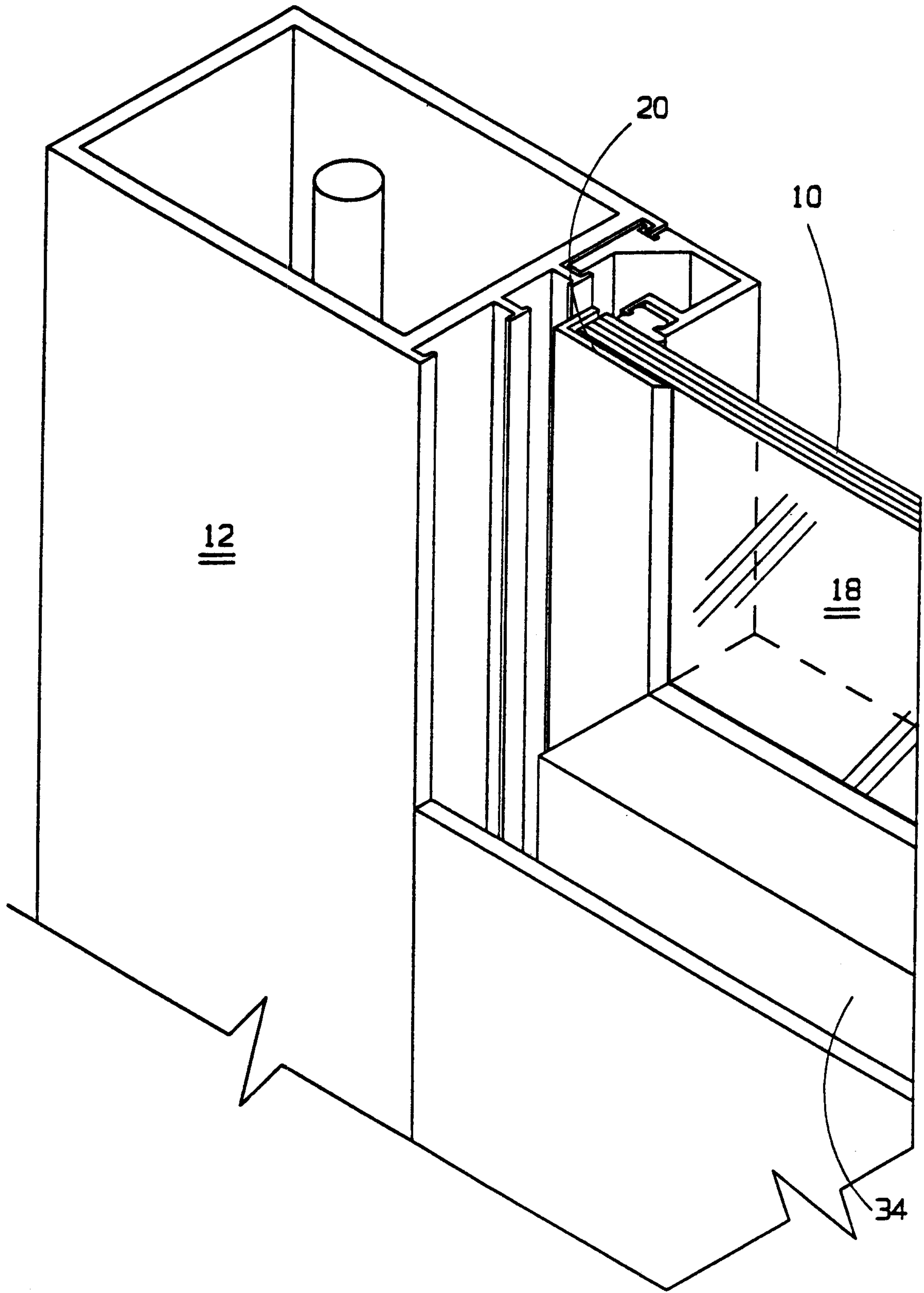

FIG. 4b

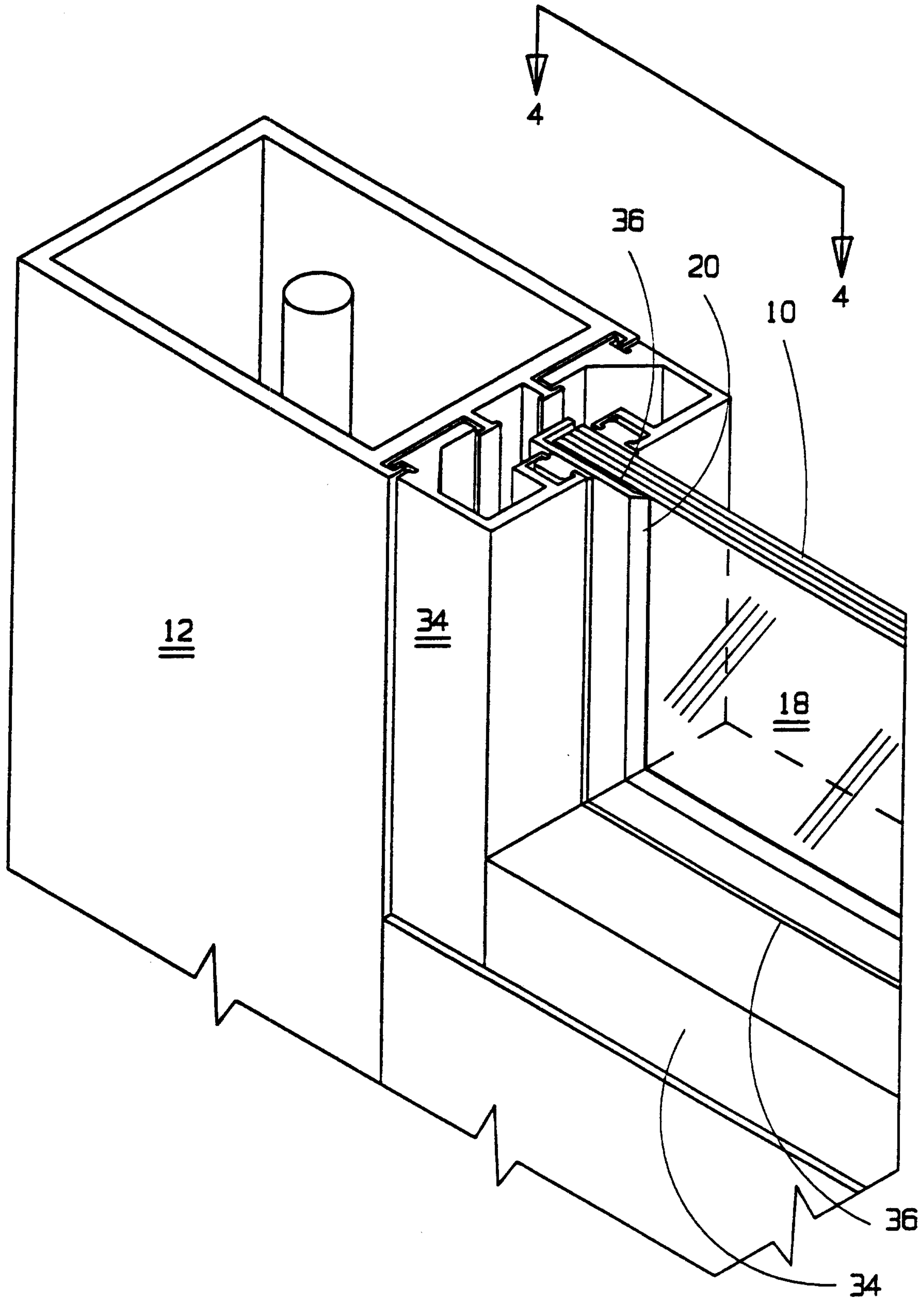

FIG. 4c