



- (51) International Patent Classification:  
*B60R 1/00* (2006.01)      *G06T 7/00* (2006.01)  
*H04N 5/235* (2006.01)
- (21) International Application Number: PCT/US2016/038639
- (22) International Filing Date: 22 June 2016 (22.06.2016)
- (25) Filing Language: English
- (26) Publication Language: English
- (30) Priority Data:  
62/182,863      22 June 2015 (22.06.2015)      US
- (71) Applicant: **GENTEX CORPORATION** [US/US]; 600 North Centennial Street, Zeeland, Michigan 49464 (US).
- (72) Inventors: **SHERMAN, Tom B.**; 600 North Centennial Street, Zeeland, Michigan 49464 (US). **BUSH, Gregory S.**; 600 North Centennial Street, Zeeland, Michigan 49464 (US). **MCMILLAN, Daniel G.**; 600 North Centennial Street, Zeeland, Michigan 49464 (US). **RADCLIFF, Dale**

**M.**; 600 North Centennial Street, Zeeland, Michigan 49464 (US). **MAJDANDZIC, Igor**; 600 North Centennial Street, Zeeland, Michigan 49464 (US).

(74) Agent: **CALLAGHAN, Terry S.**; Price Heneveld LLP, 695 Kenmoor, S.E., P.O. Box 2567, Grand Rapids, Michigan 49501-2567 (US).

(81) Designated States (unless otherwise indicated, for every kind of national protection available): AE, AG, AL, AM, AO, AT, AU, AZ, BA, BB, BG, BH, BN, BR, BW, BY, BZ, CA, CH, CL, CN, CO, CR, CU, CZ, DE, DK, DM, DO, DZ, EC, EE, EG, ES, FI, GB, GD, GE, GH, GM, GT, HN, HR, HU, ID, IL, IN, IR, IS, JP, KE, KG, KN, KP, KR, KZ, LA, LC, LK, LR, LS, LU, LY, MA, MD, ME, MG, MK, MN, MW, MX, MY, MZ, NA, NG, NI, NO, NZ, OM, PA, PE, PG, PH, PL, PT, QA, RO, RS, RU, RW, SA, SC, SD, SE, SG, SK, SL, SM, ST, SV, SY, TH, TJ, TM, TN, TR, TT, TZ, UA, UG, US, UZ, VC, VN, ZA, ZM, ZW.

(84) Designated States (unless otherwise indicated, for every kind of regional protection available): ARIPO (BW, GH, GM, KE, LR, LS, MW, MZ, NA, RW, SD, SL, ST, SZ, TZ, UG, ZM, ZW), Eurasian (AM, AZ, BY, KG, KZ, RU,

[Continued on next page]

(54) Title: SYSTEM AND METHOD FOR PROCESSING STREAMED VIDEO IMAGES TO CORRECT FOR FLICKER OF AMPLITUDE-MODULATED LIGHTS

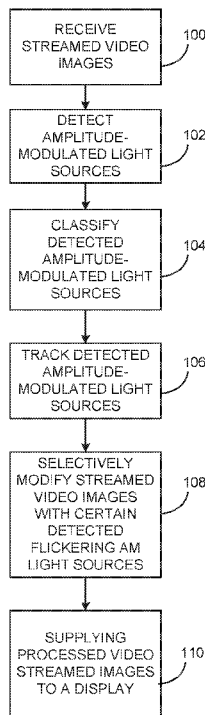

FIG. 2

(57) Abstract: A display system is provided for a vehicle equipped with a camera for supplying streamed video images of a scene rearward of the vehicle. The display system includes an image processing unit for receiving the streamed video images and processing the streamed video images, and a display for displaying the processed streamed video images. To perform processing of the streamed video images, the image processing unit is configured to: detect amplitude-modulated light sources in the streamed video images, classify the detected amplitude-modulated light sources into one of several possible classifications, select the streamed video images in which an amplitude-modulated light source is detected that flickers based upon the classification of the amplitude-modulated light source, and modify the selected streamed video images to correct for flicker of any amplitude-modulated light sources in the selected streamed video images.

WO 2016/209877 A1



TJ, TM), European (AL, AT, BE, BG, CH, CY, CZ, DE, DK, EE, ES, FI, FR, GB, GR, HR, HU, IE, IS, IT, LT, LU, LV, MC, MK, MT, NL, NO, PL, PT, RO, RS, SE, SI, SK, SM, TR), OAPI (BF, BJ, CF, CG, CI, CM, GA, GN, GQ, GW, KM, ML, MR, NE, SN, TD, TG).

— *as to the applicant's entitlement to claim the priority of the earlier application (Rule 4.17(iii))*

**Published:**

— *with international search report (Art. 21(3))*

**Declarations under Rule 4.17:**

— *as to applicant's entitlement to apply for and be granted a patent (Rule 4.17(ii))*

**SYSTEM AND METHOD FOR PROCESSING STREAMED VIDEO IMAGES  
TO CORRECT FOR FLICKER OF AMPLITUDE-MODULATED LIGHTS**

BACKGROUND OF THE INVENTION

**[0001]** The present invention generally relates to processing of video images streamed to a display, and more specifically to processing of streamed video images of scenes exterior to a vehicle. In some embodiments the present invention pertains even more specifically to processing of video images obtained from a rearward facing camera in a vehicle that are streamed to a display serving as a replacement for a rearview mirror.

SUMMARY OF THE INVENTION

**[0002]** According to one aspect of the invention, a display system is provided for a vehicle equipped with a camera for supplying streamed video images of a scene rearward of the vehicle. The display system comprising: an image processing unit for receiving the streamed video images and processing the streamed video images; and a display for displaying the processed streamed video images. To perform processing of the streamed video images, the image processing unit is configured to: detect amplitude-modulated light sources in the streamed video images, classify the detected amplitude-modulated light sources into one of several possible classifications, select the streamed video images in which an amplitude-modulated light source is detected that flickers based upon the classification of the amplitude-modulated light source, and modify the selected streamed video images to correct for flicker of any amplitude-modulated light sources in the selected streamed video images.

**[0003]** According to one aspect of the invention, a display system is provided that comprises: an image processing unit for receiving streamed video images and processing the streamed video images; and a display for displaying the processed streamed video images. To perform processing of the streamed video images, the image processing unit is configured to: detect amplitude-modulated light sources in the streamed video images, classify the detected amplitude-modulated light sources into at least two classes where a first class of detected amplitude-modulated light sources having a flicker not perceivable by a human when viewed directly by the human, and a second class of detected amplitude-modulated light sources having a flicker that is perceivable by a human when

viewed directly by the human, track the detected amplitude-modulated light sources through image frames of the streamed video images, and modify the streamed video images in which an amplitude-modulated light source is detected that is classified in the first class by substituting pixels representing each of the detected amplitude-modulated light sources that is classified in the first class such that the pixels representing the detected amplitude-modulated light source are always at a state so that when the processed streamed video images are displayed, each of the detected amplitude-modulated light sources that is classified in the first class appears to have no perceivable flicker.

**[0004]** According to one aspect of the invention, a method of processing streamed video images is provided that comprises: detecting amplitude-modulated light sources in the streamed video images; classifying the detected amplitude-modulated light sources into at least two classes where a first class of detected amplitude-modulated light sources having a flicker not perceivable by a human when viewed directly by the human, and a second class of detected amplitude-modulated light sources having a flicker that is perceivable by a human when viewed directly by the human; tracking the detected amplitude-modulated light sources through image frames of the streamed video images; and modifying the streamed video images in which an amplitude-modulated light source is detected that is classified in the first class by substituting pixels representing each of the detected amplitude-modulated light sources that is classified in the first class such that the pixels representing the detected amplitude-modulated light source are always at a state so that when the processed streamed video images are displayed, each of the detected amplitude-modulated light sources that is classified in the first class appears to have no perceivable flicker.

**[0005]** These and other features, advantages, and objects of the present invention will be further understood and appreciated by those skilled in the art by reference to the following specification, claims, and appended drawings.

#### BRIEF DESCRIPTION OF THE DRAWINGS

**[0006]** In the drawings:

**[0007]** Fig. 1 is a block diagram of an imaging system according to an embodiment of the

invention;

**[0008]** Fig. 2 is a flow chart showing the method steps performed by the image processing unit shown in Fig. 1;

**[0009]** Fig. 3 is a cut-away plan view of a vehicle in which the imaging system may be implemented;

**[0010]** Fig. 4A is a front and side perspective view of a vehicle rearview assembly in which various components of the imaging system may be implemented; and

**[0011]** Fig. 4B is a front elevational view of the vehicle rearview assembly shown in Fig. 4A.

#### DETAILED DESCRIPTION OF PREFERRED EMBODIMENTS

**[0012]** Reference will now be made in detail to the present preferred embodiments of the invention, examples of which are illustrated in the accompanying drawings. Wherever possible, the same reference numerals will be used throughout the drawings to refer to the same or like parts. In the drawings, the depicted structural elements are not to scale and certain components are enlarged relative to the other components for purposes of emphasis and understanding.

**[0013]** A common problem in rendering streaming video data captured from an imager occurs when the object being imaged is an amplitude modulated (AM) light source. A very common example of this type of light source is one which is pulsing on/off at some periodic rate, like a vehicle lamp assembly constructed with light emitting diodes (LEDs), where the LEDs are pulse-width-modulated (PWM), which is a subset of possible amplitude modulation methods. The PWM period and duty cycle result in the LEDs being turned on and off at some periodic rate, and a camera taking streaming images of this lamp assembly will capture successive images where an LED may be 'on' in one or more consecutive images, and then 'off' in one or more subsequent images. Other examples of AM light sources include the flashers on an emergency vehicle (which may also be comprised of PWM LEDs), a turn signal on a vehicle, or a fluorescent light source in a tunnel or parking garage.

**[0014]** For many of the exemplary AM light sources listed above, a human observer of the light source does not perceive any flicker in the 'on/off' pattern since the frequency

of the on/off pattern is higher than the human vision system can perceive (PWM LED headlamp/tail lamp assemblies being a prime example). But in imaging the AM light element with an electronic camera system, the exposure time, frame rate, and shutter scheme (rolling or global) used when capturing the light element at a particular pixel in the imager array may result in some images showing this pixel to be imaging an 'on' state of the light element, and successive images showing this pixel capturing the 'off' state of the light element. In attempting to render these images to a display, at some display frame rate, the display system may end up presenting the human observer an 'on/off' pattern that is discernible as a 'flickering' light.

**[0015]** Fig. 1 shows an image system 10 according to a first embodiment. As shown, image system 10 includes a camera 26 that captures images of a scene and outputs streamed video images of the scene, and a display system 12, which includes an image processing unit 30 that receives the streamed video images and processes the images (as discussed in detail below) and outputs the processed streamed video images, and a display 32 that displays the processed streamed video images.

**[0016]** The methods and processing sequences described herein are intended to mitigate the 'flickering' phenomena seen in rendered AM headlamps and tail lamps (especially targeted to PWM LED assemblies, but not limited to lighting of that technology). As described below, the platform on which these methods may be implemented is part of an automotive mirror replacement system, where a vehicle mirror is replaced by camera (lens plus digital imager) 26, image processing unit (serial processor and/or ASIC/FPGA) 30, and electronic display (LCD/LED panel) 32. The methods described herein may be incorporated in the image processing unit 30 in the above system 10. As shown in Fig. 2, the method steps may be performed in the following sequence (as would occur on the image processing unit 30): 1) receiving the streamed video images (step 100); 2) detection of the PWM LED (or AM) lights in a succession of the streamed video images (step 102); 3) differentiation/classification of the PWM LED (or AM) elements (which are part of a headlamp or tail lamp assembly) from other illuminating objects in the scene which have time-varying brightness levels (e.g. emergency vehicle lights) (step 104); 4) tracking of the pulsed lights over time (step 106); 5) correction of the flicker artifact associated with these rendered lights in a way that is appropriate to the specific type of

light source (step 108); and 6) supplying the processed video streamed images to display 32 (step 110). Possible techniques for each of these steps are detailed below.

**[0017]** Multiple methods exist for performing step 102 involving detection of time-varying lights in a sequence of captured images. In the problem area of a rearview mirror replacement system (based on an electronic camera 26, an image processing unit 30, and a display system 32), PWM LED lights that may need to be detected are those originating from vehicle headlamp and tail lamp systems. These lights are related to vehicles, which are on the same roadway as the vehicle outfitted with the mirror replacement system. The search space for the PWM LED lights of interest thus can be influenced by roadway detection, where an auto-aim or lane detection system can narrow the light search space to the vertical region above the detected road boundaries (from a lane detection system), or around the focus of expansion (from an auto aim system), and discriminated from stationary non-vehicle light sources. In this reduced search space, methods exist in existing high beam control systems to detect PWM LED lights as disclosed in commonly-owned U.S. Patent Nos. 6,587,573, 6,593,698, 6,611,610, 6,631,316, 6,653,614, 6,728,393, 6,774,988, 6,861,809, 6,906,467, 6,947,577, 7,321,112, 7,417,221, 7,565,006, 7,567,291, 7,653,215, 7,683,326, 7,881,839, 8,045,760, 8,120,652, and 8,543,254.

**[0018]** Additionally, detection methods such as frame subtraction may be used for detecting time-varying light sources, where successive images are subtracted from one another to produce temporal difference maps. The resultant maps are then processed by routines (implemented in software or in ASIC/FPGA fabric), which perform some combination of thresholding and/or filtering to identify spatial areas in the map where there were significant changes in pixel brightness between the two source images. The absolute value of the difference data indicates the magnitude of the change in pixel intensity between frames, and the sign of the difference data indicates whether the change in a pixel value between frames is associated with a light source brightening or darkening. The frame data used to generate these temporal difference maps may be raw data from a Bayer patterned image, luminance data extracted from the image, or some other image form extracted from the image processing path. On a typical roadway scene, the most significant deltas in pixel values between a pair of frames (referenced to a single pixel location), tend to be related to these PWM LED (AM) lights which are going

from extremely bright, to fully off. Motion artifacts can also contribute to temporal changes in image values at the pixel locations, but in the search space of the roadway imaged by the vehicle, this motion is quite small -- as the image capture rate is rapid compared to vehicle dynamics, and the brightness changes related to objects which do not produce their own illumination is also quite reduced (imaging a vehicle body at a pixel in the first frame to a part of the vehicle bumper in the next frame does not produce as significant a luminance change than the PWM LED is exhibiting in its on/off sequencing).

**[0019]** Other methods of detecting the presence of AM lights may be leveraged from the imager implementation, where some imagers may supply information (to the pixel level) on whether the scene brightness changed state during the pixel exposure time (especially for an imager such as an HDR CMOS imager).

**[0020]** As described below, the methods for correctly rendering pulsed lights tend to fall in the category of adding image content to 'brighten' the pulsed light location for durations when the light is captured as 'off' and addressing incorrect color measurements induced by the time-varying nature of the lights. The classification operation (step 104) is applied to discriminate between the types of time-varying light sources that introduce the brightness and /or color errors. To ensure only the desired pulsed lights are corrected (and not, for example, motion artifacts), light source classification maybe performed to influence the correction step 108. Methods of classifying PWM LED lights are known in high beam control systems such as those disclosed in commonly-owned U.S. Patent Nos. 6,587,573, 6,593,698, 6,611,610, 6,631,316, 6,653,614, 6,728,393, 6,774,988, 6,861,809, 6,906,467, 6,947,577, 7,321,112, 7,417,221, 7,565,006, 7,567,291, 7,653,215, 7,683,326, 7,881,839, 8,045,760, 8,120,652, and 8,543,254. But other options exist in the use of temporal changes, color, brightness and location. The options for use of brightness and color for classification are greatly enhanced by the use of a Bayer patterned, High Dynamic Range (HDR) imager in the camera system, since bright objects are not saturated with an HDR imager, and the Bayer pattern contributions can be demosaiced to determine color of very bright lights. Object detection systems that classify vehicles can also be used to influence the classification of PWM LED headlamps/tail lamps, by limiting search windows to areas associated with the

identified vehicles.

**[0021]** Basically, the classification can be used to distinguish between those flickering lights that are humanly perceivable when viewing the lights directly from those lights that are not humanly perceivable as flickering when viewing the lights directly. This way, the images of the light sources may be selectively modified based upon such classification so that the light sources will appear in the displayed scenes as they would otherwise appear to a human viewing the lights directly.

**[0022]** The step of temporal tracking of pulsed lights (step 106) can be performed using the techniques for tracking vehicle lights as described in known high beam control systems such as those disclosed in commonly-owned U.S. Patent Nos. 6,587,573, 6,593,698, 6,611,610, 6,631,316, 6,653,614, 6,728,393, 6,774,988, 6,861,809, 6,906,467, 6,947,577, 7,321,112, 7,417,221, 7,565,006, 7,567,291, 7,653,215, 7,683,326, 7,881,839, 8,045,760, 8,120,652, 8,543,254, and 9,185,363. This temporal and spatial tracking is useful when selectively modifying the images in order to brighten pixels corresponding to the expected location of the flickering light source in those modified images.

**[0023]** Step 108 involves resolving light flicker for rendering on display 32. With the AM (or pulsed) lights which need to be addressed for display flicker reduction identified, the method of flicker reduction can be performed by substituting low pixel values (from 'off' situations), with values which correspond to levels associated with 'on' situations. The pixel value replacements can be performed at the raw level (a Bayer pattern color associated with the replaced pixel), or at a later processing step in the processing subsystem. There are advantages to performing pixel replacement at the post-demosaic step, and color can be preserved for the PWM light by creating the correct balance of red, green and blue contributions. To maintain the displayed boundaries of AM light objects when pixel substitution is being performed, some image processing steps may be used to predict the object outline in an upcoming frame by using the tracking information of step 106, and an object shape detection routine.

**[0024]** Alternatively, the temporal difference maps from the detection step can be used to define the region of pixels to be substituted (since they represent the pixels which have changed state between frames), with better results possible from using maps that incorporate more than just a two frame difference. One possible implementation of this

method would involve creating difference maps of pixel values (by location) across sequences of frames, replacing pixel values that have been determined to be producing images of pulsed PWM LED lights with an average of the highest M values in an N frame sequence (M less than N), if the average of highest M values exceeds some threshold. If analysis of overall image luminance and object color is used, this replacement method may also be used to replace PWM LED detection, classification, tracking and replacement.

**[0025]** A forward-facing turn signal is one example of a time-varying light source that could be detected, classified, and corrected using the ideas disclosed here. Unlike a PWM light, whose row-to-row values on the imager may vary greatly due to beat frequencies, a turn signal's frequency is significantly lower than a camera's frame rate (1-2 Hz as opposed to 15-120 Hz). This results in areas of the light turning on and off at the turn signal's frequency. This spatial consistency within the boundaries of the light, coupled with a detected frequency that is indicative of a turn signal and a yellowish hue, could allow classification of a light as a turn signal as it is tracked. Once the system knows what kind of light it is, the system can fix it by increasing its yellow saturation, creating more visual appeal, but leave its on/off behavior alone.

**[0026]** A PWM LED tail lamp is a difficult object to image and visualize correctly because it is typically not relatively bright compared to the background. In addition, for rolling shutter cameras, each row of pixels may have a sharply different level of brightness, and this can be exacerbated by the spatial effects of the Bayer filter, leading to many artifacts in both chrominance and luminance. However, some of these characteristics—row-to-row variation, local colors that are wildly different, and colors and intensities that change drastically from frame to frame, etc.—in addition to other characteristics—location in the image, predominance of brighter red pixels, motion toward the focus of expansion, frequency estimation on the light modulation, etc.—could allow classification of these lights with high accuracy. Fixing PWM LED tail lamps could be performed by making the colors a uniformly saturated red while choosing a luminance from the detected range, which would end up being visually appealing and remove harsh artifacts.

**[0027]** Referring now to Fig. 3, a schematic diagram of a vehicular implementation of the above embodiment is shown. A vehicle 20 is shown that is driven by operator 22. One or

more cameras 26 are operative to view a scene 24. In the example shown, scene 24 is generally behind vehicle 20. However, camera 26 may be oriented in a variety of ways to view scenes at other locations about vehicle 20 including, but not limited to, the sides, back, front, bottom, top, and inside. In the example shown, signals representative of the scene are sent via channel 28 to an image processing unit 30. Image processing unit 30 produces an enhanced image of scene 24 on one or more displays 32. Input from an optional ambient light sensor 34 and one or more direct glare sensors 36 is also available to image processing unit 30.

**[0028]** In a particularly useful embodiment, a rearview assembly 50 (Figs. 4A and 4B) is augmented or replaced by imaging system 10 having cameras 26 which cover a wide field of view to the back and sides so that pedestrians or other objects directly in back of vehicle 20 may be seen and so that oncoming traffic from the sides may be seen. The system is designed so that, when backing out of a parking spot, oncoming vehicles may be seen before backing into the lane of travel. This requires camera system 26 with a near 180° field of view or several camera systems 26 mounted near the rear of the vehicle. An analogous system with a camera or cameras 26 mounted near the front of the vehicle 20 is adapted to view cross traffic at a “blind” intersection before entering the lane of travel of the cross traffic. These are desirable applications for the present invention which supplement the viewing function of conventional rearview mirrors.

**[0029]** Figs. 4A and 4B show an example of a rearview assembly 50 having a housing 54 with a display 32 and an optional mirror element 52 positioned in front of the display 32. A user switch 56 may optionally be provided for tilting of the mirror element 52 and/or display 32 to reduce glare on the display 32 when activated. Examples of such a rearview assembly 50 are known and are disclosed in commonly-owned U.S. Patent Application Publication Nos. 2015/0219967 A1, 2015/0266427 A1, and 2015/0277203 A1. The optional ambient light sensor 34 and a direct glare sensor 36 may be incorporated in rearview assembly 50 as is known in the art. Further, image processing unit 30 may be disposed in the rearview assembly 50. Rearview assembly 50 may be an interior rearview assembly as shown in Figs. 4A and 4B, or may be an exterior rearview assembly.

**[0030]** The above description is considered that of the preferred embodiments only. Modifications of the invention will occur to those skilled in the art and to those who

make or use the invention. Therefore, it is understood that the embodiments shown in the drawings and described above are merely for illustrative purposes and not intended to limit the scope of the invention, which is defined by the claims as interpreted according to the principles of patent law, including the doctrine of equivalents.

CLAIMS

What is claimed is:

1. A display system for a vehicle equipped with a camera for supplying streamed video images of a scene rearward of the vehicle, the display system comprising:
  - an image processing unit for receiving the streamed video images and processing the streamed video images; and
  - a display for displaying the processed streamed video images,wherein to perform processing of the streamed video images, the image processing unit is configured to:
  - detect amplitude-modulated light sources in the streamed video images,
  - classify the detected amplitude-modulated light sources into one of several possible classifications,
  - select the streamed video images in which an amplitude-modulated light source is detected that flickers based upon the classification of the amplitude-modulated light source, and
  - modify the selected streamed video images to correct for flicker of any amplitude-modulated light sources in the selected streamed video images.
2. The display system of claim 1, wherein the image processing unit modifies the selected streamed video images such that the pixels representing each of the detected amplitude-modulated light sources are maintained at a state so that when the processed streamed video images are displayed, each of the detected amplitude-modulated light sources that is represented by the pixels appears to have no perceivable flicker.
3. The display system of claim 2, wherein each of the detected amplitude-modulated light sources are maintained by substituting low pixel values from off periods with higher pixel values from on periods.
4. The display system of any one of claims 1-3, wherein the image processing unit is further configured to track the detected amplitude-modulated light sources through

image frames of the streamed video images.

5. The display system of claim 4, wherein the image processing unit modifies the selected streamed video images such that the pixels representing each of the detected amplitude-modulated light sources are maintained at a state so that when the processed streamed video images are displayed, each of the detected amplitude-modulated light sources that is represented by the pixels appears to have no perceivable flicker and appears at the expected locations in the images based upon the tracking of each of the detected amplitude-modulated light sources.

6. The display system of any one of claims 1-5, wherein the image processing unit does not modify the streamed video images to correct for flicker from light sources classified as a turn signal or emergency vehicle light.

7. The display system of any one of claims 1-6, wherein the image processing unit classifies the detected amplitude-modulated light sources into at least two classes where a first class of detected amplitude-modulated light sources having a flicker not perceivable by a human when viewed directly by the human, and a second class of detected amplitude-modulated light sources having a flicker that is perceivable by a human when viewed directly by the human.

8. The display system of claim 7, wherein the streamed video images in which an amplitude-modulated light source is detected that is classified in the first class is modified by substituting pixels representing each of the detected amplitude-modulated light sources that is classified in the first class such that the pixels representing each of the detected amplitude-modulated light sources are always at a state so that when the processed streamed video images are displayed, the detected amplitude-modulated light source that is classified in the first class appears to have no perceivable flicker.

9. The display system of any one of claims 7-8, wherein the image processing unit classifies the detected amplitude-modulated light sources into the first class when a

frequency of the flicker in the light sources is above a threshold frequency and classifies the detected amplitude-modulated light sources into the second class when a frequency of the flicker in the light sources is below the threshold frequency.

10. A rearview assembly for mounting to the vehicle, the rearview assembly comprising the display system of any one of claims 1-9.

11. A display system comprising:

an image processing unit for receiving streamed video images and processing the streamed video images; and

a display for displaying the processed streamed video images,  
wherein to perform processing of the streamed video images, the image processing unit is configured to:

detect amplitude-modulated light sources in the streamed video images,  
classify the detected amplitude-modulated light sources into at least two classes where a first class of detected amplitude-modulated light sources having a flicker not perceivable by a human when viewed directly by the human, and a second class of detected amplitude-modulated light sources having a flicker that is perceivable by a human when viewed directly by the human,

track the detected amplitude-modulated light sources through image frames of the streamed video images, and

modify the streamed video images in which an amplitude-modulated light source is detected that is classified in the first class by substituting pixels representing each of the detected amplitude-modulated light sources that is classified in the first class such that the pixels representing the detected amplitude-modulated light source are always at a state so that when the processed streamed video images are displayed, each of the detected amplitude-modulated light sources that is classified in the first class appears to have no perceivable flicker.

12. The display system of claim 11, wherein the image processing unit classifies the

detected amplitude-modulated light sources into the first class when a frequency of the flicker in the light sources is above a threshold frequency and classifies the detected amplitude-modulated light sources into the second class when a frequency of the flicker in the light sources is below the threshold frequency.

13. The display system of claim 12, wherein each of the detected amplitude-modulated light sources are maintained by substituting low pixel values from off periods with higher pixel values from on periods.

14. The display system of any one of claims 11-13, wherein the image processing unit does not modify the streamed video images to correct for flicker from light sources classified in the second class.

15. The display system of claim 14, wherein light sources classified in the second class include turn signals and emergency vehicle lights.

16. A rearview assembly for mounting to the vehicle, the rearview assembly comprising the display system of any one of claims 11-15.

17. A method of processing streamed video images comprising:  
detecting amplitude-modulated light sources in the streamed video images;  
classifying the detected amplitude-modulated light sources into at least two classes where a first class of detected amplitude-modulated light sources having a flicker not perceivable by a human when viewed directly by the human, and a second class of detected amplitude-modulated light sources having a flicker that is perceivable by a human when viewed directly by the human;  
tracking the detected amplitude-modulated light sources through image frames of the streamed video images; and  
modifying the streamed video images in which an amplitude-modulated light source is detected that is classified in the first class by substituting pixels representing each of the detected amplitude-modulated light sources that is classified in the first class

such that the pixels representing the detected amplitude-modulated light source are always at a state so that when the processed streamed video images are displayed, each of the detected amplitude-modulated light sources that is classified in the first class appears to have no perceivable flicker.

18. The method of claim 17, wherein the detected amplitude-modulated light sources are classified into the first class when a frequency of the flicker in the light sources is above a threshold frequency and are classified into the second class when a frequency of the flicker in the light sources is below the threshold frequency.

19. The method of any one of claims 17-18, wherein the light sources classified in the second class are not corrected for flicker.

20. The method of claim 19, wherein light sources classified in the second class include turn signals and emergency vehicle lights.

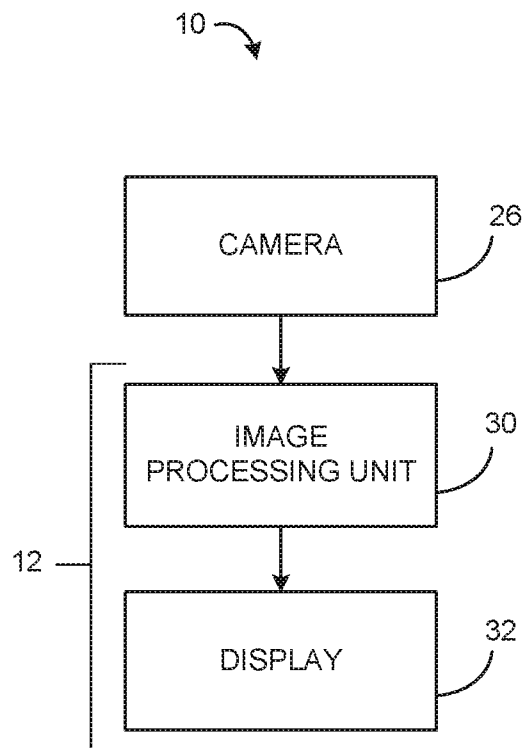

FIG. 1

2/4

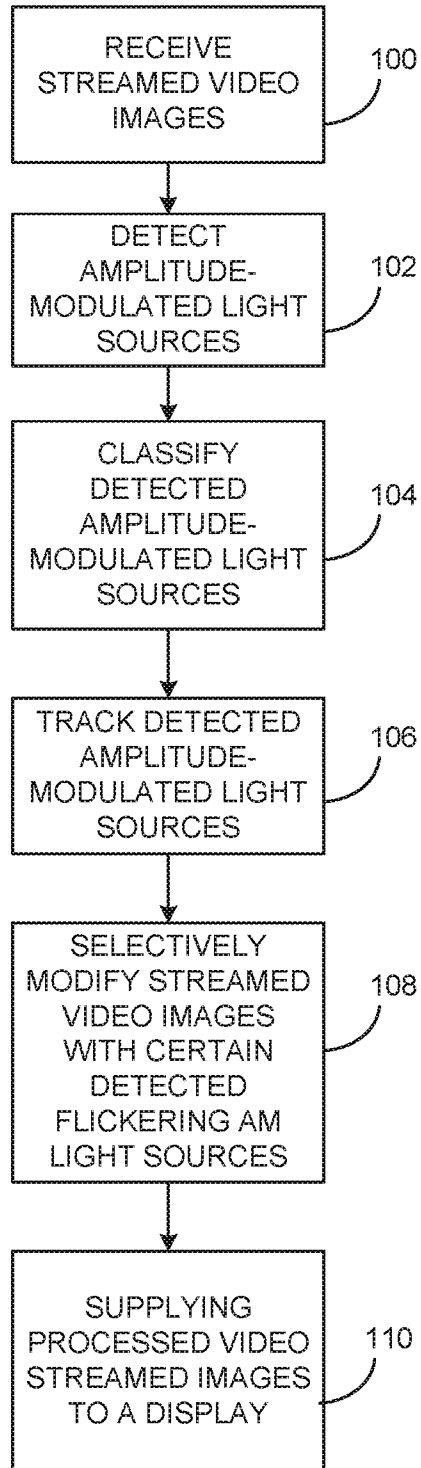

FIG. 2

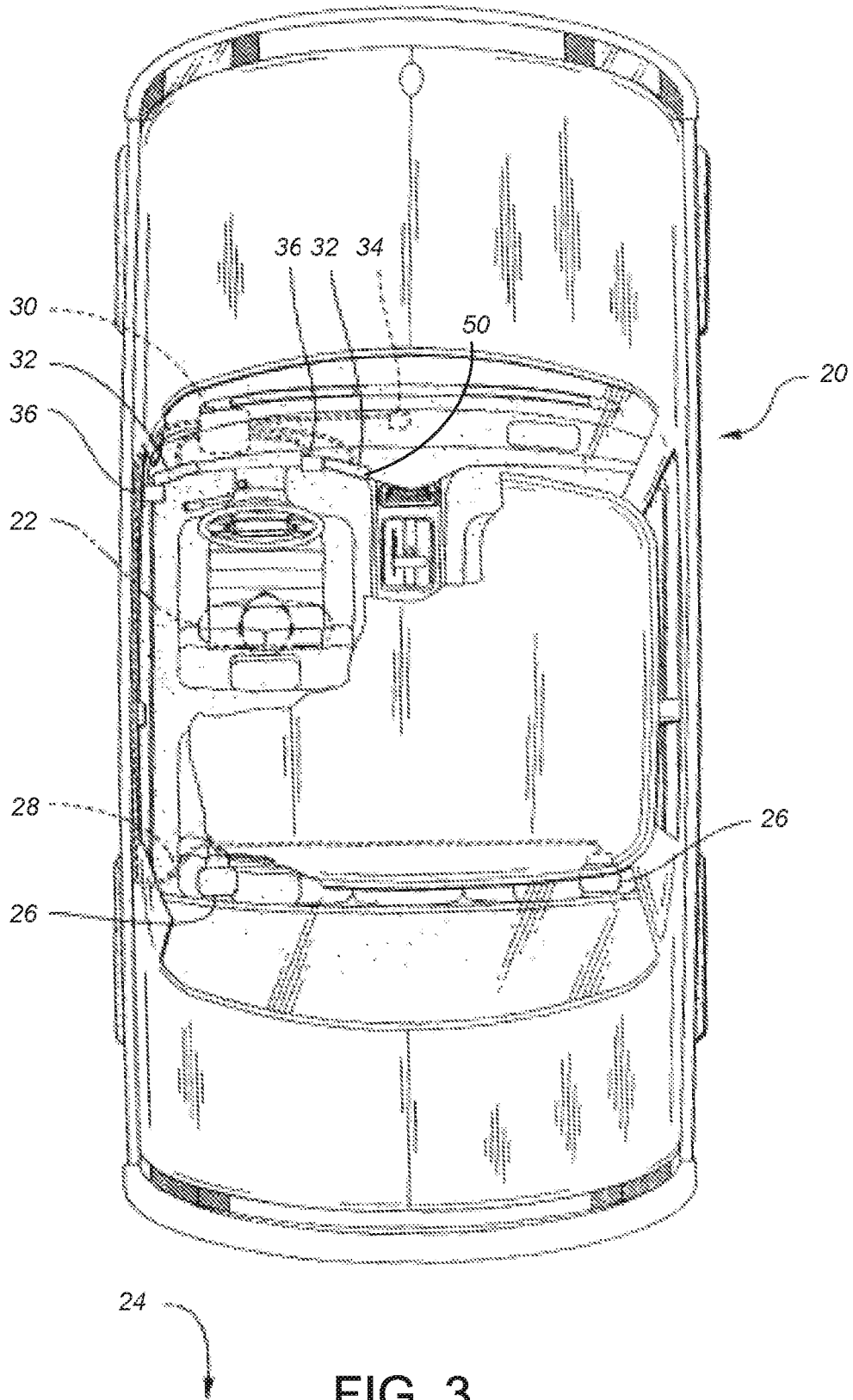

FIG. 3

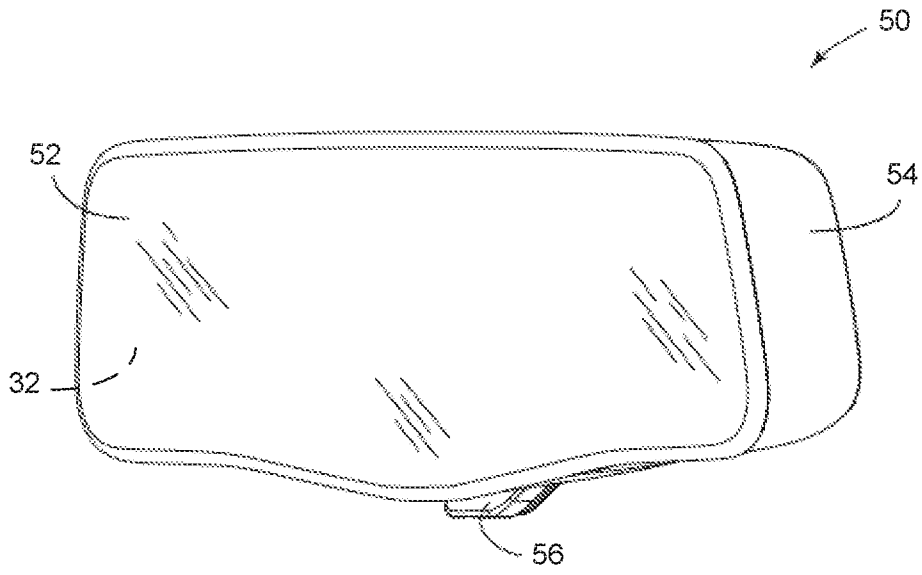

FIG. 4A

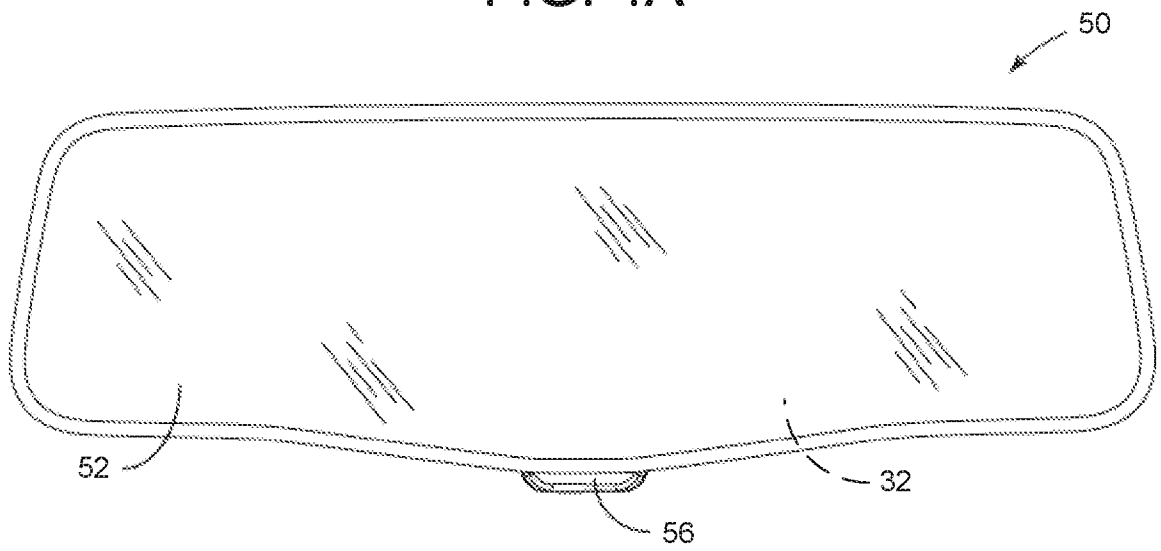

FIG. 4B

## INTERNATIONAL SEARCH REPORT

International application No.

PCT/US 2016/038639

A. CLASSIFICATION OF SUBJECT MATTER		
<b>B60R 1/00 (2006.01)</b> <b>H04N 5/235 (2006.01)</b> <b>G06T 7/00 (2006.01)</b>		
According to International Patent Classification (IPC) or to both national classification and IPC		
B. FIELDS SEARCHED		
Minimum documentation searched (classification system followed by classification symbols)		
B60R 1/00-1/12, H04N 5/00, 5/225, 5/243, G06T 7/00		
Documentation searched other than minimum documentation to the extent that such documents are included in the fields searched		
Electronic data base consulted during the international search (name of data base and, where practicable, search terms used)		
PatSearch (RUPTO internal), USPTO, PAJ, Esp@cenet, DWPI, EAPATIS, PATENTSCOPE, Information Retrieval System of FIPS		
C. DOCUMENTS CONSIDERED TO BE RELEVANT		
Category*	Citation of document, with indication, where appropriate, of the relevant passages	Relevant to claim No.
X	JP 2009214795 A (NISSAN MOTOR) 24.09.2009, [0001], [0008], [0013]-[0017], [0020]-[0024], fig.1, 2	1-5, 10-20
A	US 2006/0054783 (TRANSCHIP, INC) 16.03.2006	1-5, 10-20
A	JP 2009038666 A (CANON INC) 19.02.2009	1-5, 10-20
<input type="checkbox"/> Further documents are listed in the continuation of Box C. <input type="checkbox"/> See patent family annex.		
* Special categories of cited documents:	“T”	later document published after the international filing date or priority date and not in conflict with the application but cited to understand the principle or theory underlying the invention
“A” document defining the general state of the art which is not considered to be of particular relevance	“X”	document of particular relevance; the claimed invention cannot be considered novel or cannot be considered to involve an inventive step when the document is taken alone
“E” earlier document but published on or after the international filing date	“Y”	document of particular relevance; the claimed invention cannot be considered to involve an inventive step when the document is combined with one or more other such documents, such combination being obvious to a person skilled in the art
“L” document which may throw doubts on priority claim(s) or which is cited to establish the publication date of another citation or other special reason (as specified)	“&”	document member of the same patent family
“O” document referring to an oral disclosure, use, exhibition or other means		
“P” document published prior to the international filing date but later than the priority date claimed		
Date of the actual completion of the international search	Date of mailing of the international search report	
21 September 2016 (21.09.2016)	29 September 2016 (29.09.2016)	
Name and mailing address of the ISA/RU: Federal Institute of Industrial Property, Berezhkovskaya nab., 30-1, Moscow, G-59, GSP-3, Russia, 125993 Facsimile No: (8-495) 531-63-18, (8-499) 243-33-37	Authorized officer  R. Artemiev  Telephone No. (499) 240-25-91	

**INTERNATIONAL SEARCH REPORT**

International application No.

PCT/US 2016/038639

**Box No. II Observations where certain claims were found unsearchable (Continuation of item 2 of first sheet)**

This international search report has not been established in respect of certain claims under Article 17(2)(a) for the following reasons:

1.  Claims Nos.:  
because they relate to subject matter not required to be searched by this Authority, namely:
  
2.  Claims Nos.:  
because they relate to parts of the international application that do not comply with the prescribed requirements to such an extent that no meaningful international search can be carried out, specifically:
  
3.  Claims Nos.: 6-9  
because they are dependent claims and are not drafted in accordance with the second and third sentences of Rule 6.4(a).

**Box No. III Observations where unity of invention is lacking (Continuation of item 3 of first sheet)**

This International Searching Authority found multiple inventions in this international application, as follows:

1.  As all required additional search fees were timely paid by the applicant, this international search report covers all searchable claims.
2.  As all searchable claims could be searched without effort justifying additional fees, this Authority did not invite payment of additional fees.
3.  As only some of the required additional search fees were timely paid by the applicant, this international search report covers only those claims for which fees were paid, specifically claims Nos.:
4.  No required additional search fees were timely paid by the applicant. Consequently, this international search report is restricted to the invention first mentioned in the claims; it is covered by claims Nos.:

**Remark on Protest**

- The additional search fees were accompanied by the applicant's protest and, where applicable, the payment of a protest fee.
- The additional search fees were accompanied by the applicant's protest but the applicable protest fee was not paid within the time limit specified in the invitation.
- No protest accompanied the payment of additional search fees.