

D. Simmons. Street 1. & Streets.

Paper Box Mach.

No. 100,459.

Patented Mar. 1, 1870.

Fig. 1.

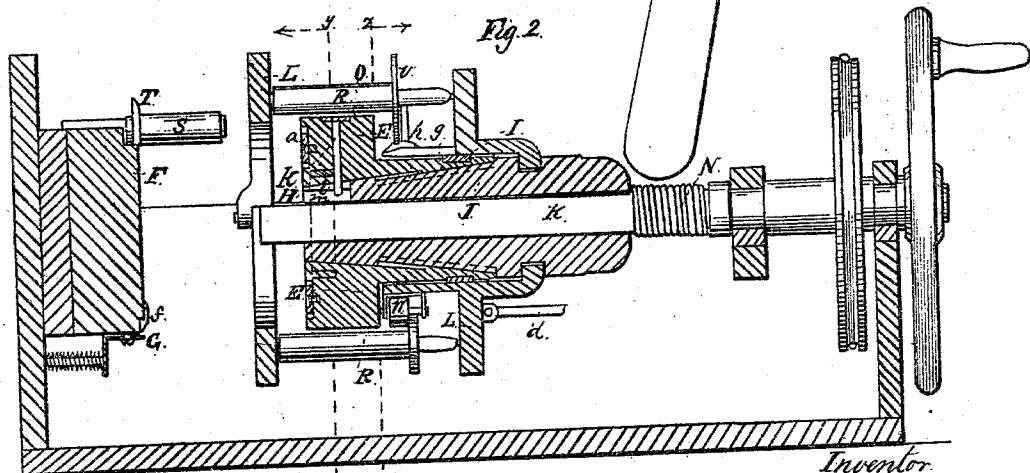
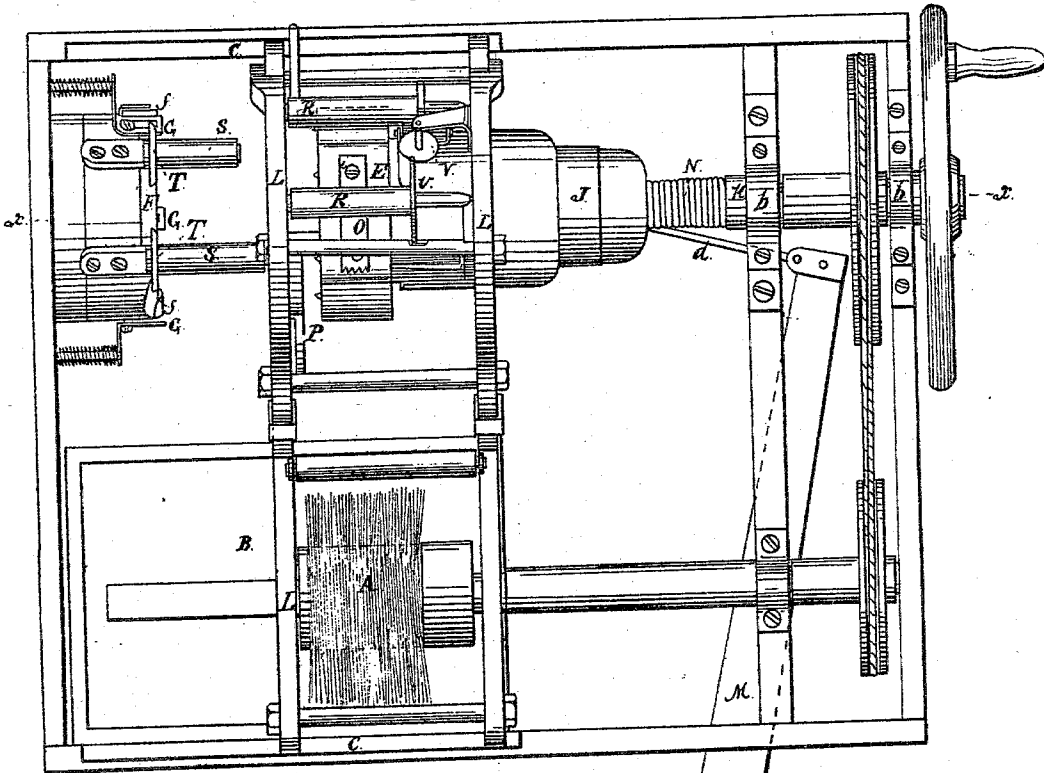

Witnesses.  
Fred Payne  
M. Hardy

Inventor.  
Daniel Simmons

*D. Simmons. Sheet 2. of 2 Sheets.  
Paper Box Mach.*

*N<sup>o</sup> 100,459.*

*Patented Mar. 1, 1870.*

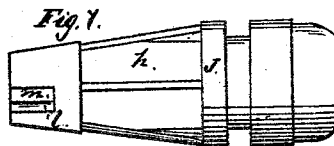
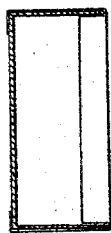
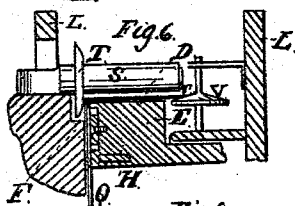
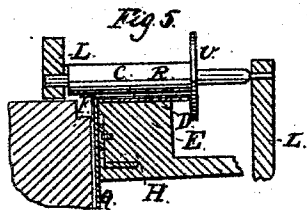
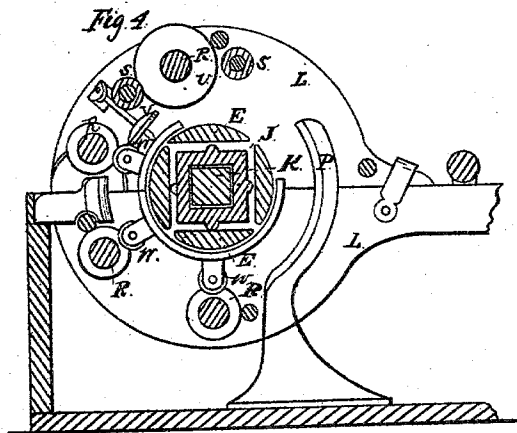
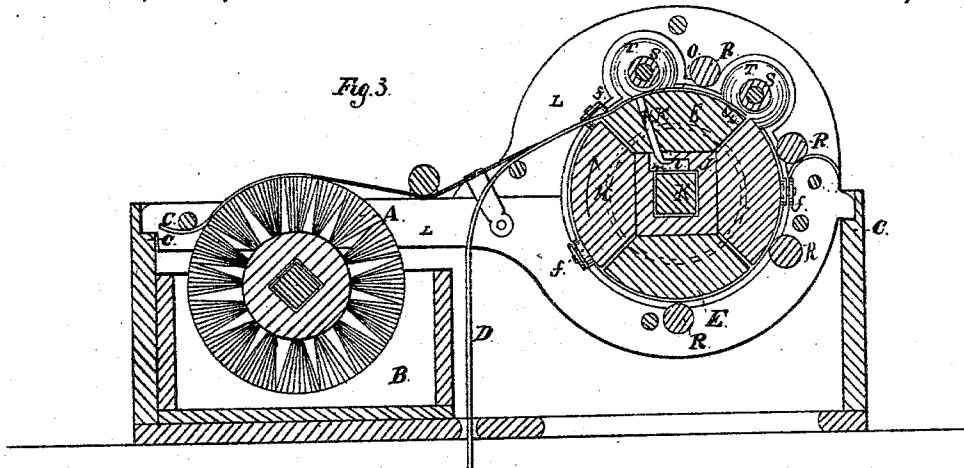

*Witnesses  
Fred Hayes  
J. P. Haulig*

*Inventor  
Daniel Simmons*

# United States Patent Office.

DANIEL SIMMONS, OF NEW YORK, N. Y.

Letters Patent No. 100,459, dated March 1, 1870.

## IMPROVEMENT IN PAPER-BOX MACHINES.

The Schedule referred to in these Letters Patent and making part of the same.

To all whom it may concern:

Be it known that I, DANIEL SIMMONS, of the City, county, and State of New York, have invented a new and useful Improvement in Machinery for Making Paper Boxes, of which the following is a full, clear, and exact description, reference being had to the accompanying drawing forming part of this specification, and in which—

Figure 1 represents a plan of a machine for making paper boxes, constructed in accordance with my improvement.

Figure 2, a longitudinal vertical section of the same, taken as indicated by the line *x x* in fig. 1.

Figures 3 and 4, transverse sections, taken as denoted by the lines *y y* and *z z* in fig. 2, and looking in opposite directions.

Figures 5 and 6, sectional views through the revolving block or "former," in part, in connection with other parts or devices immediately connected with the putting on of the paper strip that covers and closes the body of the box; also, unites the bottom or end therewith.

Figure 7, a longitudinal view of a sliding taper socket, on or around which the block or former is arranged.

Figure 8 is a sectional view of a box as made by the machine.

Similar letters of reference indicate corresponding parts.

In the machine represented in the accompanying drawing, the box or its lid, of circular form, is made by first suitably centering the disk which forms its end or bottom, and then feeding into the machine, on or around a suitably-arranged revolving block or "former," a strip of pasteboard to form the body of the box, and simultaneously therewith a paper covering, having paste applied to its one surface, and of greater width than the body, so that in being wrapped around the body, as the same are rotated in common, said covering is not only made to form a pasted wrapper to the body, closing the seam or joint in the pasteboard, but is turned over the edges or ends of the body to unite the bottom with the latter, and to give a turned-over finish to the open or opposite end. This is the same or general principle of action of the invention, which includes various peculiarities in the construction of certain parts or devices, and novel combinations of details for carrying out the same in a practicable and advantageous manner.

Referring to the accompanying drawing—

A is a revolving brush, which is arranged to dip or work in a paste-receptacle, B, and over which the paper strip C, that covers and closes the body of the box, also unites its bottom or end, is passed simultaneously with the feed of the pasteboard strip D, to a revolving block or former, E.

Arranged opposite this revolving block E is a stationary face-plate or block, F. In making a box, the disk which forms its end or bottom is laid against this face-plate F, and supported and centered by being placed on adjustable gauges G, which are acted upon by springs at their backs, so as to admit of their being pressed back or inward. The revolving block or former E is of sectional construction, for the purpose of allowing of its expansion and contraction, to facilitate its hold on the box while being made, and removal of the same when made.

Said sections, which are radial as regards arrangement, are closed and held together by elastic bands H I, in conjunction with a front ring, a, provided with prickers, to effect the rotation of the end along with the body of the box, and secured to the sections by screws, fitted so as to admit of radial play to the sections.

The expansion of said "former" is effected by means of a sliding taper socket, J, arranged to fit on or over a central driving-shaft, K, that, as well as the taper-socket and block or former, are of such construction in their transverse sections as that their rotation in common is insured, on motion being communicated to the driving-shaft K, which rests in bearings *b b*.

The taper socket J, carrying the block or former E, also the pasting-brush A, and sundry rollers and devices, as hereinafter described, connected with the guiding and laying of the strip or strips, are arranged within a frame, L, that is made capable of sliding along suitable ways *c c*, in a direction or directions parallel to the driving-shaft K, and is drawn back by a hand-lever, M, and rod *d*, when it is required to slide the block E and its pertaining parts or devices away from the fixed face-plate F, but is forced up toward the latter by a spring, N, arranged around the shaft K. The frame L may be hinged as at *e*, so as to open where it encircles or covers the block or former E.

Arranged across and otherwise in connection with said frame L are sundry rollers and disks or wheels, operating in connection with similar devices arranged to project from the block that carries the face-plate F, all of which will be found hereinafter particularized in describing the operation of the machine.

Also, the face-plate F is provided with rollers *f* to facilitate the rotation of the end or bottom along with the body of the box in the course of its manufacture, and serving to close the paper in its lap over the end or bottom of the box.

The former E is constructed at its rear end with an inwardly-projecting collar-portion, *g*, and the taper socket J with a recessed portion or surface, *h*, of greater length, (see figs. 2 and 7,) so that in drawing said socket back along with the sliding frame L, it is free to move a given distance before it pulls on or draws

back the "former," the object of which will be herein-after explained.

Furthermore, said "former" E is provided, on the periphery of one of its radial sections, with a hinged or elastic flap-like clamp, *o*, having its root as at *i*, and sitting, when closed, into a recess formed in said section, so as to lie flush, or thereabouts, with the periphery of said section. This clamp, which is serrated at its forward or mouth-end, serves to hold the strips C and D at their one end, to secure their being wrapped on the revolving "former."

Said clamp is made automatic in its action. That may be effected by means of a spring hook or catch-rod, *k*, arranged to project from it, and to bite under a lip, *l*, formed on one side of a slot, *m*, in the forward end of the socket J. This lip *l* is not only made sloping in direction of the taper of the socket J, but beveled off in a crosswise direction thereto, as seen in figs. 3 and 7, so that while on drawing back the socket J in advance of its pulling on the "former," as hereinbefore described, the lip *l* clears the hook *k* and opens the clamp *o*. A reverse motion given to the socket J causes the hook *k* to be thrown by the bevel or bevels of the lip *l*, under and in lock with the latter, closing the clamp. Said clamp *o* is thus opened at each fresh feed of paper and pasteboard to the "former," and opened after the box is made to allow of its removal from the "former," which is effected by a stripper, P, through the continued further back-sliding action given to the socket J after it has commenced to pull on the "former," by the collar and recessed construction of these devices, as at *g* and *h*, the stripper operating to remove the box, as the latter in the sliding of the "former" is brought against it.

It may here be remarked that, on starting the socket J back, and until, by its shouldered construction, it pulls on the former, the frictional hold of the box on the latter, as caused by devices used in forming the box, prevents the former E from being drawn by frictional contact along with the socket, which secures the opening of the clamp *o* to release the box, for its after removal by the stripper, as described.

In making the box, the "former" E and socket J are, of course, pressed forward with the disk Q, that forms the end or bottom to the box, between said "former" and the face-plate F, the pasteboard D and covering-paper C, which form the body of the box, having previously been fed to the "former" when the clamp *o* was open, or the socket J may be temporarily drawn back to effect the opening of the clamp for that purpose.

The strip of pasted paper C for each box should be so adjusted relatively to the pasteboard body piece or strip D as to secure wrap of the paper over the pasteboard at the joint or seam in the box.

Said paper also requires to be considerably wider than the pasteboard, to allow of its being folded or turned at its edges, as represented in figs. 5, 6, and 8, for the purpose of connecting the body of the box with

its bottom Q, and for giving a turned-over finish to the open end of the box. The paper is properly guided and bent to effect this, and made to bear with its pasted side on the pasteboard; also, the close fit of the latter on the "former" secured, by means of rollers and disks, or wheels, as follows.

R R is a series of guiding and pressing rollers carried by the frame L, and

S S similar rollers, arranged to project from the block carrying the face-plate F.

These several rollers are arranged to surround the "former" E in directions parallel to its axis, and serve to make the strips C and D conform to the rotundity of the "former," and to cement or paste them together as the "former" E is revolved.

On the rollers S S are disks T T, which operate, the first in a preparatory and the second in a finishing manner, to break and turn the one edge of the paper C over the end or bottom Q, after which the rollers *f f*, hereinbefore described, flatten or complete such lap by pressing the pasted surface of such turned-over-edge portion on to the disk Q. This unites the bottom or end with the body of the box.

The opposite edge of the pasted strip C is folded or turned over the open end of the box, as shown in fig. 8, first, by breaking it into a right-angled position by a disk, U, on the advance roller R, afterward turning such bend inward by its passage over a beveled wheel or disk, V, and subsequently, during the rotation of the "former" passing such inwardly-bent edge, together with the mouth-end of the pasteboard body and outer portion of the covering-paper, between the after rollers R and supplementary rollers W. This causes the pasted paper to be turned over, and to be cemented or pasted to the open end of the box, both on its inside and outside, as represented in fig. 8. The rollers R are provided with suitable flanges or shoulders to guide the paper.

After the box has been thus made, it is removed from off the former E by drawing back the socket J, as hereinbefore described.

What is here claimed, and desired to be secured by Letters Patent, is—

1. The combination of the sliding frame L with the paste-brush A, and the revolving block or former E, substantially as specified.

2. The combination, with the former E, of the rollers S S, with their disks T-T, and the rollers *f f*, essentially as herein set forth.

3. The combination, with the former E, of the rollers R R, the revolving disk U, the beveled wheel or disk V, and the rollers W, substantially as described.

4. The combination of the stripper P with the revolving and sliding former E, essentially as specified.

DANIEL SIMMONS.

Witnesses:

FRED. HAYNES,  
M. J. SHANLY.