

(19) World Intellectual Property Organization
International Bureau



(43) International Publication Date
16 September 2010 (16.09.2010)

(10) International Publication Number
WO 2010/104890 A2

(51) International Patent Classification:
H01L 31/0232 (2006.01)

(21) International Application Number:
PCT/US2010/026722

(22) International Filing Date:
9 March 2010 (09.03.2010)

(25) Filing Language: English

(26) Publication Language: English

(30) Priority Data:
61/158,529 9 March 2009 (09.03.2009) US

(71) Applicant (for all designated States except US): **THE UNIVERSITY OF NORTH CAROLINA AT CHARLOTTE** [US/US]; 9201 University City Boulevard, Charlotte, NC 28223 (US).

(72) Inventors; and

(75) Inventors/Applicants (for US only): **HASAN, Mo-hamad-Ali** [US/US]; The University Of North Carolina at Charlotte, Department of Electrical and Computer Engineering, 9201 University City Boulevard, Charlotte, NC 28223 (US). **FIDDY, Michael** [US/US]; The University of North Carolina at Charlotte, Department of Electrical and Computer Engineering, 9201 University City Boule-

vard, Charlotte, NC 28223 (US). **GOVEAS, Terence** [IN/US]; The University of North Carolina at Charlotte, Department of Electrical and Computer Engineering, 9201 University City Boulevard, Charlotte, NC 28223 (US).

(74) Agents: **WRIGHT, James, D.** et al.; Tillman Wright, PLLC, PO Box 49309, Charlotte, NC 28277 (US).

(81) Designated States (unless otherwise indicated, for every kind of national protection available): AE, AG, AL, AM, AO, AT, AU, AZ, BA, BB, BG, BH, BR, BW, BY, BZ, CA, CH, CL, CN, CO, CR, CU, CZ, DE, DK, DM, DO, DZ, EC, EE, EG, ES, FI, GB, GD, GE, GH, GM, GT, HN, HR, HU, ID, IL, IN, IS, JP, KE, KG, KM, KN, KP, KR, KZ, LA, LC, LK, LR, LS, LT, LU, LY, MA, MD, ME, MG, MK, MN, MW, MX, MY, MZ, NA, NG, NI, NO, NZ, OM, PE, PG, PH, PL, PT, RO, RS, RU, SC, SD, SE, SG, SK, SL, SM, ST, SV, SY, TH, TJ, TM, TN, TR, TT, TZ, UA, UG, US, UZ, VC, VN, ZA, ZM, ZW.

(84) Designated States (unless otherwise indicated, for every kind of regional protection available): ARIPO (BW, GH, GM, KE, LS, MW, MZ, NA, SD, SL, SZ, TZ, UG, ZM, ZW), Eurasian (AM, AZ, BY, KG, KZ, MD, RU, TJ, TM), European (AT, BE, BG, CH, CY, CZ, DE, DK, EE, ES, FI, FR, GB, GR, HR, HU, IE, IS, IT, LT, LU, LV, MC, MK, MT, NL, NO, PL, PT, RO, SE, SI, SK, SM,

[Continued on next page]

(54) Title: EFFICIENCY ENHANCEMENT OF SOLAR CELLS USING LIGHT MANAGEMENT

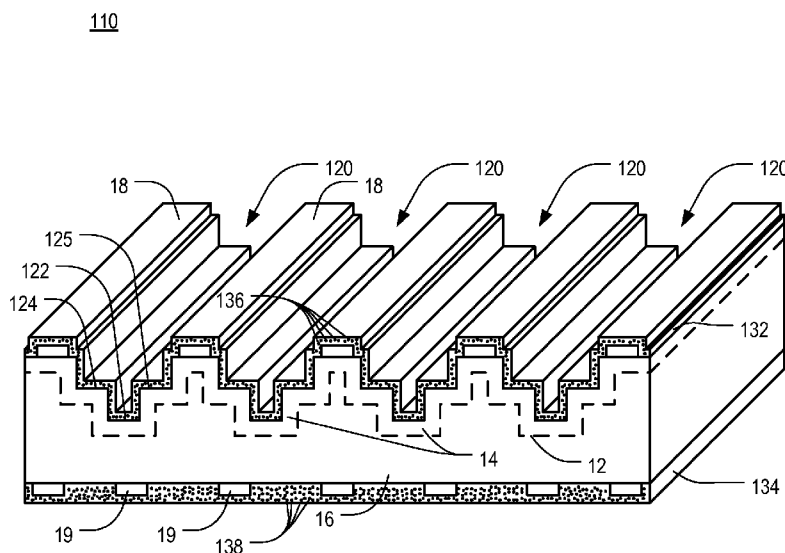

FIG. 5

(57) Abstract: A photovoltaic cell includes a junction, formed from an n-type semiconductor material and a p-type semiconductor material, a trench, opening toward the light-incident side of the junction, for trapping reflected light, and two photon conversion layers. A first photon conversion layer, arranged at the light-incident side of the junction, converts photons from a higher energy to a lower energy suitable for absorption by the semiconductor material, and a second photon conversion layer, arranged at the opposite side of the junction, converts photons from a lower energy to a higher energy suitable for absorption by the semiconductor material.



WO 2010/104890 A2

TR), OAPI (BF, BJ, CF, CG, CI, CM, GA, GN, GQ, GW, ML, MR, NE, SN, TD, TG). **Published:**

— *without international search report and to be republished upon receipt of that report (Rule 48.2(g))*

EFFICIENCY ENHANCEMENT OF SOLAR CELLS USING LIGHT MANAGEMENT

CROSS-REFERENCE TO RELATED APPLICATION

[0001] For purposes of the United States, the present application is a U.S. nonprovisional patent application of, and claims priority under 35 U.S.C. § 119(e) to, U.S. provisional patent application serial number 61/158,529, filed March 9, 2009, the entirety of which is expressly incorporated by reference herein.

COPYRIGHT STATEMENT

[0002] All of the material in this patent document is subject to copyright protection under the copyright laws of the United States and of other countries. The copyright owner has no objection to the facsimile reproduction by anyone of the patent document or the patent disclosure, as it appears in the Patent and Trademark Office patent file or records, but otherwise reserves all copyright rights whatsoever.

BACKGROUND OF THE PRESENT INVENTION

Field of the Present Invention

[0003] The present invention relates generally to photovoltaic cells, and, in particular, to photovoltaic cells having improved surface geometries coated with layers doped with phosphors for both down-conversion and up-conversion.

Background

[0004] Photovoltaic solar cells are a well-known technology. The solar market is growing at a rapid speed; annual shipments of solar cell modules have been increasing at a rate of over 30% in the past few years.

[0005] As shown in FIG. 1, a conventional solar cell **10** includes an n-type semiconductor material **14** and a p-type semiconductor material **16**. The n-type semiconductor material **14** is doped with impurity atoms to form an electrically negative material that already has a few electrons in its conduction band. The p-type semiconductor material **16** is doped to leave missing electrons, or holes, in its valence band. The junction **12** between the n- and p-type semiconductor materials **14,16** creates a voltage bias. When the solar cell absorbs incoming photons, electrons are caused to migrate toward the positive side of the junction **12** and holes toward the negative side, forming an electric current.

[0006] Unfortunately, the efficiency of conventional solar cells—that is, the proportion of the sunlight falling on the solar cell that is converted to electricity—is very low. Sunlight comes in many colors, combining low-energy infrared photons with high-energy ultraviolet photons and all the visible-light photons in between. The visible region of the solar spectrum, whose photons have wavelengths of between 400 nm and 700 nm and energies of between 3.1 eV and 1.77 eV, contains only about 43% of the irradiance. The ultraviolet region of the solar spectrum, whose photons have wavelengths less than 400 nm and energies of greater than 3.1 eV, contains about 5% of the total irradiance, while the infrared region, whose photons have wavelengths of greater than 700 nm and energies of less than 1.7 eV, contains about 52% of the irradiance. This is demonstrated in FIG. 2, which is a graphical representation of the relative photon energies present in sunlight under standardized conditions. In particular, solar radiation flux, measured in photons per second per meter squared, is plotted against photon energies for sunlight incident on the earth's surface under the well-established AM1.5 standard. Flux is utilized in FIG. 2 instead of irradiance ($\text{W}/\text{m}^2 \times \text{nm}$) because flux is the only one-to-one relevant value when it comes to generation of carriers within the cell.

[0007] Each photovoltaic material responds to a narrow range of these energies, corresponding to its characteristic band gap, which is the amount of energy, expressed in electron volts (eV), that are required to kick an electron from a semiconductor's valence band (where electrons, bound to atoms, are plentiful) into its empty conduction band. Photons with energy lower than the band gap escape unabsorbed, while photons with higher energy are absorbed, but most of their energy is wasted as heat. Because band gaps are so limited, typical solar cells have efficiencies of no more than 25%, meaning most of the sunlight falling on them is not converted to electricity.

[0008] One common photovoltaic material is silicon (Si). FIG. 3 is a graphical representation illustrating the dependence of silicon absorption depth on light energy. As demonstrated in FIG. 3, Si is almost transparent to photons with energies lower than its bandgap. These photons do not contribute to the generation of electron-hole pairs. At an intermediate energy range of $3 \text{ eV} > E > 1.5 \text{ eV}$, Si absorbs light to a depth ranging from about 0.1 to 10 microns. In this range, Si has its maximum efficiency for solar cell applications. Electron-hole pairs are generated within the junction volume (for most cells) and are driven to the contacts by the built-in field. At energies higher than about 3 eV, the light is absorbed in the sub-surface area, 100 nm from the surface. Since carriers are generated near the surface and there is no built-in field to drive the carriers to the surface, a

large proportion of these carriers recombine at surface states or within the subsurface layer, thereby resulting in minimal contribution to the generated current and much of the absorbed energy being converted to heat. In summary, Si utilizes about 45% of the incident light, assuming that the light is absorbed, minimal amount is reflected, and carriers are collected efficiently.

[0009] Because of these shortcomings, researchers in a number of different fields have pursued a variety of different approaches for improving the efficiency of solar cells. For example, materials researchers have proposed the use of different materials with different band gaps that can be stacked to capture photons with a wider range of energies. Such a “multijunction” solar cell includes a top junction that captures high-energy photons but allows lower-energy photons to pass through to one or more lower-band gap junctions below. Theoretically, efficiencies of 50% could be produced using such an approach. Unfortunately, it is very difficult to stack conventional materials, and matching materials with different crystal lattices is difficult and often impossible, and the actual efficiencies that have been produced thus far have been far less.

[0010] Another approach that has been proposed is the use of a “multi-band gap material,” wherein a single semiconductor produces multiple band gaps, thereby converting multiple spectral ranges to electricity. By replacing a few of the host atoms in a semiconductor alloy with nitrogen or oxygen atoms having a very different electronegativity, a split band gap can be produced, which in some materials produces a narrow band well below the normal conduction band. The presence of these two separate bands means the material efficiently absorbs photons of three different energies. The difference between the material’s valence band and the lower of the split bands forms a first band gap, absorbing photons of a first energy level; the difference between the two split bands is a second band gap, absorbing photons of a second energy level; and the difference between the valence band and the upper conducting band forms a third band gap, absorbing photons of a third energy level. Such an approach could theoretically produce efficiencies in excess of 50%. However, research and development of this approach is still in its infancy, and unfortunately there are significant manufacturing hurdles to be crossed before such an approach will be able to find commercial success.

[0011] Another group of researchers, typically involved in the investigation and use of improved manufacturing techniques, has been exploring the use of optically-engineered surface geometries to minimize surface reflection and maximize absorption of light. Most or all of the efforts in this regard have focused on increasing the surface area of

the material relative to the volume. For example, porous silicon is a skeleton of single crystalline silicon filled with randomly structured voids that result in a high surface to volume ratio. Thus, any junction built into the structure will have a much larger junction volume (depletion region) proportional to the surface area. However, a significant challenge with porous silicon is the high density of surface states within the porous structure, which leads to carrier recombination at the surface before collection by the electrodes. In other words, carrier removal to improve the efficiency of the solar cell has proven difficult to achieve.

[0012] Another group of researchers has been exploring the use of optically-engineered surface geometries to minimize surface reflection and maximize absorption of light. For example, U.S. Patent Application Pub. No. 2009/0295257 discloses the use of a variety of surface features, including an array of surface pyramids, an array of trenches, an array of corrugations, an array of crenulations, an array of nano-bowls, and combinations thereof. FIG. 4 is a schematic diagram, in isometric form, of a solar cell **11** having conventional corrugated trenches **20**. However, while useful for better capturing or “trapping” light within the solar cell, these geometries are all still relatively crude, more frequently and a need exists for improved surface geometries for greater efficiencies. Furthermore, in part because researchers involved in optically engineering the surfaces of photovoltaic cells are rarely, if ever, materials researchers, the use of surface geometries has not been combined with other techniques to provide greater efficiency improvements. Thus, a need exists for still further improvements in surface geometries as well as in the use of optical engineering with other techniques.

[0013] Still another group of researchers, typically involved in materials research rather than manufacturing techniques, have proposed the use of a photon conversion layer, disposed on the top or light-incident side of the solar cell, for converting the wavelength of a portion of the photons received thereby to a different wavelength for better absorption thereof. For example, both U.S. Patent Application Pub. No. 2010/0012177 and U.S. Patent Application Pub. No. 2009/0255577 disclose a photon-conversion layer. However, researchers have only heretofore utilized a single layer, thereby performing down-conversion (from high-energy photons to low-energy photons) or up-conversion (from low-energy photons to high-energy photons) but not both, and no researcher has yet proposed the use of a second such layer on the opposite side of the solar cell. Furthermore, although efficiency improvements may have been achieved using such a single layer, the phosphors or other materials used to cause the energy (wavelength) conversion create additional reflectivity, thereby causing at least some amount of loss in efficiency because of the extra sunlight that is

reflected from the surface of the cell. Thus, a need exists for the combination of a down-conversion layer, an up-conversion layer, or both with improved surface geometries to achieve less reflection in combination with an energy (wavelength) conversion process in a solar cell. This, and other needs, are addressed by one or more aspects of the present invention.

SUMMARY OF THE INVENTION

[0014] The present invention includes many aspects and features. Moreover, while many aspects and features relate to, and are described in, the context of photovoltaic cells, the present invention is not limited to use only in photovoltaic cells, as will become apparent from the following summaries and detailed descriptions of aspects, features, and one or more embodiments of the present invention.

[0015] Broadly defined, the present invention according to a first aspect includes a photovoltaic cell including a junction formed from an n-type semiconductor material and a p-type semiconductor material and having a light-incident side and an opposite side. The photovoltaic cell further includes a trench, opening toward the light-incident side of the junction, for trapping reflected light; a first photon conversion layer that converts photons from a higher energy to a lower energy suitable for absorption by the semiconductor material; and a second photon conversion layer that converts photons from a lower energy to a higher energy suitable for absorption by the semiconductor material.

[0016] In features of this aspect, the trench may include a top, a lowermost surface, and at least one plateau elevated above the lowermost surface but disposed below the top of the trench; the trench may further include an additional plateau disposed between the at least one plateau and the top of the trench; the trench may further include an additional plateau disposed between the lowermost surface and the at least one plateau; the at least one plateau may be inclined or declined relative to other surfaces of the trench; and the lowermost surface may be inclined or declined relative to other surfaces of the trench.

[0017] In further features of this aspect, the second photon conversion layer may be arranged on the opposite side of the junction; the first photon conversion layer may be arranged on the light-incident side of the junction; the first photon conversion layer may be an antireflective coating layer; the second photon conversion layer may include phosphor particles embedded therein, the phosphor particles selected to convert photons passing through the junction unabsorbed from a lower energy to a higher energy; the phosphor

particles may be nano-particles; the phosphor particles may be micro-particles; and the second photon conversion layer may be a reflective coating layer.

[0018] In still further features of this aspect, the composition of the first photon conversion layer may be selected to optimize subsequent absorption of the lower-energy photons, converted thereby, by the semiconductor material; the composition of the second photon conversion layer may be selected to optimize subsequent absorption of the higher-energy photons, converted thereby, by the semiconductor material; an upper wall of the trench may be inclined or declined relative to other surfaces of the trench; and a lower wall of the trench may be inclined or declined relative to other surfaces of the trench.

[0019] In still further features of this aspect, the photovoltaic cell may further include a hollow, opening toward the opposite side of the junction, for minimizing carrier travel path to one or more contacts, for minimizing attenuation of long wavelength light used for up-conversion, or both; the photovoltaic cell may further include an electrical contact disposed in the hollow; and the second photon conversion layer may be arranged at least partially in the hollow.

[0020] In still further features of this aspect, at least a portion of the cross-section or profile of the trench may be hexagonal in shape; the hexagonally-shaped portion of the trench profile may open directly to the light-incident side of the junction; and the hexagonally-shaped portion of the trench profile may open to the light-incident side of the junction via a passage that is narrower than the width of the hexagonally-shaped portion.

[0021] Broadly defined, the present invention according to a second aspect includes a photovoltaic cell including a junction formed from an n-type semiconductor material and a p-type semiconductor material and having a light-incident side and an opposite side. The photovoltaic cell further includes a stepped trench, opening toward the light-incident side of the junction, for trapping reflected light, that has a top, a lowermost surface, and at least one plateau elevated above the lowermost surface but disposed below the top of the stepped trench.

[0022] In features of this aspect, the stepped trench may further include an additional plateau disposed between the at least one plateau and the top of the stepped trench; and the stepped trench may further include an additional plateau disposed between the lowermost surface and the at least one plateau.

[0023] In further features of this aspect, the photovoltaic cell may further include a photon conversion layer; the photon conversion layer may be arranged on the light-incident side of the junction; the photon conversion layer may be a first photon conversion layer, and

a second photon conversion layer may be arranged on the opposite side of the junction; the second photon conversion layer may be arranged on the opposite side of the junction; the first photon conversion layer may be arranged on the light-incident side of the junction; the first photon conversion layer may be an antireflective coating layer; the second photon conversion layer may include phosphor particles embedded therein, the phosphor particles selected to convert photons passing through the junction unabsorbed from a lower energy to a higher energy; the phosphor particles may be nano-particles; the phosphor particles may be micro-particles; the second photon conversion layer may be a reflective coating layer; the composition of the first photon conversion layer may be selected to optimize subsequent absorption of lower-energy photons, converted by the first photon conversion layer to a higher energy, by the semiconductor material; and the composition of the second photon conversion layer may be selected to optimize subsequent absorption of higher-energy photons, converted by the second photon conversion layer to a lower energy, by the semiconductor material.

[0024] In still further features of this aspect, the at least one plateau may be inclined or declined relative to other surfaces of the stepped trench; the lowermost surface may be inclined or declined relative to other surfaces of the stepped trench; an upper wall of the stepped trench may be inclined or declined relative to other surfaces of the stepped trench; and a lower wall of the stepped trench may be inclined or declined relative to other surfaces of the stepped trench.

[0025] In still further features of this aspect, the photovoltaic cell may further include a hollow, opening toward the opposite side of the junction, for minimizing carrier travel path to one or more contacts, for minimizing attenuation of long wavelength light used for up-conversion, or both; the photovoltaic cell may further include an electrical contact disposed in the hollow; and a photon conversion layer may be arranged at least partially in the hollow.

[0026] Broadly defined, the present invention according to a third aspect includes a photovoltaic cell including a junction formed from an n-type semiconductor material and a p-type semiconductor material and having a light-incident side and an opposite side. The photovoltaic cell further includes a stepped trench, opening toward the light-incident side of the junction, for trapping reflected light. The cross-section or profile of the stepped trench includes a top, a lowermost boundary, and at least one plateau elevated above the lowermost boundary but disposed below the top.

[0027] In features of this aspect, the stepped trench may further include an additional plateau disposed between the at least one plateau and the top of the stepped trench; and the stepped trench may further include an additional plateau disposed between the lowermost boundary and the at least one plateau.

[0028] In further features of this aspect, the photovoltaic cell may further include a photon conversion layer; the photon conversion layer may be arranged on the light-incident side of the junction; the photon conversion layer may be a first photon conversion layer, and a second photon conversion layer may be arranged on the opposite side of the junction; the first photon conversion layer may be an antireflective coating layer; the second photon conversion layer may include phosphor particles embedded therein, the phosphor particles selected to convert photons passing through the junction unabsorbed from a lower energy to a higher energy; the phosphor particles may be nano-particles; the phosphor particles may be micro-particles; the second photon conversion layer may be a reflective coating layer; the composition of the first photon conversion layer may be selected to optimize subsequent absorption of lower-energy photons, converted by the first photon conversion layer to a higher energy, by the semiconductor material; and the composition of the second photon conversion layer may be selected to optimize subsequent absorption of higher-energy photons, converted by the second photon conversion layer to a lower energy, by the semiconductor material.

[0029] In still further features of this aspect, the at least one plateau may be inclined or declined relative to other surfaces of the stepped trench; the lowermost surface may be inclined or declined relative to other surfaces of the stepped trench; an upper wall of the stepped trench may be inclined or declined relative to other surfaces of the stepped trench; and a lower wall of the stepped trench may be inclined or declined relative to other surfaces of the stepped trench.

[0030] In still further features of this aspect, the photovoltaic cell may further include a hollow, opening toward the opposite side of the junction, for minimizing carrier travel path to one or more contacts, for minimizing attenuation of long wavelength light used for up-conversion, or both; the photovoltaic cell may further include an electrical contact disposed in the hollow; and a photon conversion layer may be arranged at least partially in the hollow.

[0031] Broadly defined, the present invention according to a fourth aspect includes a photovoltaic cell including a junction formed from an n-type semiconductor material and a p-type semiconductor material and having a light-incident side and an opposite

side; a trench, opening toward the light-incident side of the junction, for trapping reflected light; and a reflective layer. The reflective layer is disposed on the side of the junction, opposite the light-incident side of the junction, that includes phosphor particles that convert photons which pass through the semiconductor material, without being absorbed, from a lower energy to a higher energy suitable for subsequent absorption by the semiconductor material.

[0032] In features of this aspect, the trench may include a top, a lowermost surface, and at least one plateau elevated above the lowermost surface but disposed below the top of the trench; the trench may further include an additional plateau disposed between the at least one plateau and the top of the trench; the trench may further include an additional plateau disposed between the lowermost surface and the at least one plateau; the at least one plateau may be inclined or declined relative to other surfaces of the trench; the lowermost surface may be inclined or declined relative to other surfaces of the trench; an upper wall of the trench may be inclined or declined relative to other surfaces of the trench; a lower wall of the trench may be inclined or declined relative to other surfaces of the trench; the phosphor particles may be nano-particles; the phosphor particles may be micro-particles; and the composition of the reflective layer may be selected to optimize subsequent absorption of the higher-energy photons, converted thereby, by the semiconductor material.

[0033] In further features of this aspect, the photovoltaic cell may further include a hollow, opening toward the opposite side of the junction, for minimizing carrier travel path to one or more contacts, for minimizing attenuation of long wavelength light used for up-conversion, or both; the photovoltaic cell may further include an electrical contact disposed in the hollow; and the reflective layer may be arranged at least partially in the hollow.

[0034] In still further features of this aspect, at least a portion of the cross-section or profile of the trench may be hexagonal in shape; the hexagonally-shaped portion of the trench profile may open directly to the light-incident side of the junction; and the hexagonally-shaped portion of the trench profile may open to the light-incident side of the junction via a passage that is narrower than the width of the hexagonally-shaped portion.

[0035] Broadly defined, the present invention according to a fifth aspect includes a photovoltaic cell including a junction formed from an n-type semiconductor material and a p-type semiconductor material and having a light-incident side and an opposite side. The photovoltaic cell further includes a trench, opening toward the light-incident side of the junction, for trapping reflected light. At least a portion of the cross-section or profile of the trench is hexagonal in shape.

[0036] In features of this aspect, the hexagonally-shaped portion of the trench profile may open directly to the light-incident side of the junction; and the hexagonally-shaped portion of the trench profile may open to the light-incident side of the junction via a passage that is narrower than the width of the hexagonally-shaped portion.

[0037] In further features of this aspect, the photovoltaic cell may further include a photon conversion layer; the photon conversion layer may be arranged on the light-incident side of the junction; the photon conversion layer may be a first photon conversion layer, and a second photon conversion layer may be arranged on a side of the junction that is opposite the light-incident side; the first photon conversion layer may be an antireflective coating layer; the second photon conversion layer may include phosphor particles embedded therein, the phosphor particles selected to convert photons passing through the junction unabsorbed from a lower energy to a higher energy; the phosphor particles may be nano-particles; the phosphor particles may be micro-particles; the second photon conversion layer may be a reflective coating layer; the composition of the first photon conversion layer may be selected to optimize subsequent absorption of the lower-energy photons, converted thereby, by the semiconductor material; and the composition of the second photon conversion layer may be selected to optimize subsequent absorption of the higher-energy photons, converted thereby, by the semiconductor material.

[0038] In still further features of this aspect, the photovoltaic cell may further include a hollow, opening toward a side of the junction that is opposite the light-incident side, for minimizing carrier travel path to one or more contacts, for minimizing attenuation of long wavelength light used for up-conversion, or both; the photovoltaic cell may further include an electrical contact disposed in the hollow; and a photon conversion layer may be arranged at least partially in the hollow.

[0039] In addition to the aforementioned aspects and features of the present invention, it should be noted that the present invention further encompasses the various possible combinations and subcombinations of such aspects and features.

BRIEF DESCRIPTION OF THE DRAWINGS

[0040] Further features, embodiments, and advantages of the present invention will become apparent from the following detailed description with reference to the drawings, wherein:

FIG. 1 is a schematic diagram, in isometric form, of a conventional solar cell, including an n-type semiconductor material and a p-type semiconductor material;

FIG. 2 is a graphical representation of the relative photon energies present in sunlight under standardized conditions;

FIG. 3 is a graphical representation illustrating the dependence of silicon absorption depth on light energy;

FIG. 4 is a schematic diagram, in isometric form, of a solar cell having conventional corrugated trenches;

FIGS. 5 and 6 are schematic diagrams, in isometric and cross-sectional form, respectively, of an improved-efficiency solar cell in accordance with a first preferred embodiment of the present invention;

FIG. 7 is a graphical representation of the intensity of the excitation and resulting emission from an exemplary phosphor of photons of various wavelengths;

FIG. 8 is a graphical representation of the intensity of the emission resulting from an exemplary phosphor of photons of wavelengths between about 800 and 1400 nm;

FIGS. 9 and FIG. 10 are enlarged cross-sectional views of a portion of the cell of FIG. 6 illustrating the improved operational efficiencies thereof;

FIGS. 11 and 12 are schematic diagrams, in isometric and cross-sectional form, respectively, of an improved-efficiency solar cell in accordance with a second preferred embodiment of the present invention;

FIGS. 13 and 14 are schematic diagrams, in isometric and cross-sectional form, respectively, of a solar cell having only the optically designed surface for improved angle-independent absorption of light in accordance with a third preferred embodiment of the present invention;

FIGS. 15 and 16 are schematic diagrams, in isometric and cross-sectional form, respectively, of a solar cell having an improved rear or bottom surface geometry in accordance with a fourth preferred embodiment of the present invention;

FIG. 17 is a schematic diagram, in isometric form, of a solar cell having another optically designed surface for improved angle-independent absorption of light in accordance with a fifth preferred embodiment of the present invention; and

FIG. 18 is a schematic diagram, in isometric form, of a solar cell having another optically designed surface for improved angle-independent absorption of light in accordance with a sixth preferred embodiment of the present invention.

DETAILED DESCRIPTION OF THE PREFERRED EMBODIMENTS

[0041] As a preliminary matter, it will readily be understood by one having ordinary skill in the relevant art (“Ordinary Artisan”) that the present invention has broad utility and application. Furthermore, any embodiment discussed and identified as being “preferred” is considered to be part of a best mode contemplated for carrying out the present invention. Other embodiments also may be discussed for additional illustrative purposes in providing a full and enabling disclosure of the present invention. Moreover, many embodiments, such as adaptations, variations, modifications, and equivalent arrangements, will be implicitly disclosed by the embodiments described herein and fall within the scope of the present invention.

[0042] Accordingly, while the present invention is described herein in detail in relation to one or more embodiments, it is to be understood that this disclosure is illustrative and exemplary of the present invention, and is made merely for the purposes of providing a full and enabling disclosure of the present invention. The detailed disclosure herein of one or more embodiments is not intended, nor is to be construed, to limit the scope of patent protection afforded the present invention, which scope is to be defined by the claims and the equivalents thereof. It is not intended that the scope of patent protection afforded the present invention be defined by reading into any claim a limitation found herein that does not explicitly appear in the claim itself.

[0043] Thus, for example, any sequence(s) and/or temporal order of steps of various processes or methods that are described herein are illustrative and not restrictive. Accordingly, it should be understood that, although steps of various processes or methods may be shown and described as being in a sequence or temporal order, the steps of any such processes or methods are not limited to being carried out in any particular sequence or order, absent an indication otherwise. Indeed, the steps in such processes or methods generally may be carried out in various different sequences and orders while still falling within the scope of the present invention. Accordingly, it is intended that the scope of patent protection afforded the present invention is to be defined by the appended claims rather than the description set forth herein.

[0044] Additionally, it is important to note that each term used herein refers to that which the Ordinary Artisan would understand such term to mean based on the contextual use of such term herein. To the extent that the meaning of a term used herein—as understood by the Ordinary Artisan based on the contextual use of such term—differs in any way from

any particular dictionary definition of such term, it is intended that the meaning of the term as understood by the Ordinary Artisan should prevail.

[0045] Furthermore, it is important to note that, as used herein, “a” and “an” each generally denotes “at least one,” but does not exclude a plurality unless the contextual use dictates otherwise. Thus, reference to “a picnic basket having an apple” describes “a picnic basket having at least one apple” as well as “a picnic basket having apples.” In contrast, reference to “a picnic basket having a single apple” describes “a picnic basket having only one apple.”

[0046] When used herein to join a list of items, “or” denotes “at least one of the items,” but does not exclude a plurality of items of the list. Thus, reference to “a picnic basket having cheese or crackers” describes “a picnic basket having cheese without crackers”, “a picnic basket having crackers without cheese”, and “a picnic basket having both cheese and crackers.” Finally, when used herein to join a list of items, “and” denotes “all of the items of the list.” Thus, reference to “a picnic basket having cheese and crackers” describes “a picnic basket having cheese, wherein the picnic basket further has crackers,” as well as describes “a picnic basket having crackers, wherein the picnic basket further has cheese.”

[0047] Referring now to the drawings, in which like numerals represent like components throughout the several views, the preferred embodiments of the present invention are next described. The following description of the preferred embodiment(s) is merely exemplary in nature and is in no way intended to limit the invention, its application, or uses.

[0048] FIGS. 5 and 6 are schematic diagrams, in isometric and cross-sectional form, respectively, of an improved-efficiency solar cell **110** in accordance with a first preferred embodiment of the present invention. As shown therein, the solar cell **110** includes a junction **12** formed from an n-type semiconductor material **14** and a p-type semiconductor material **16** and a plurality of contacts **18,19** providing an electrical connection thereto. The materials selected as the n- and p-type semiconductor materials **14,16** may be of any conventional combination.

[0049] The cell **110** includes a series of stepped trenches **120** opening upward, each having a lowermost surface **122** and at least one plateau **124,125** elevated above the lowermost surface **122** but disposed below the top of the trench **120**. The arrangement of stepped trenches **120** provides significant improvement with regard to scattering and hence absorption of light with minimal dependence on the radiation’s incident angle. Known surface geometries, such as that illustrated in FIG. 4, are able to trap some of the photons that

would otherwise be reflected back away from the cell **10** through the use of the walls of the trench **20**, which block the upward path of some of the reflected sunlight. However, photons from light falling on central portions of the trenches **20** of the conventional cell **10** of FIG. 4 are lost, while photons from light falling on central portions of the trenches **120** of the solar cell **110** of FIG. 5 fall between the adjacent plateaus **124,125** toward the lowermost surface **122** of the trench **120**. Some fall on the lower walls of the trench **120**, while others reach the lowermost surface **122** directly. In either case, a portion of the photons are absorbed, and an ever-dwindling portion are reflected, where they are likely to reach yet another surface within the trench **120**.

[0050] As shown in FIGS. 5 and 6, the cell **110** also includes an antireflective coating layer **132** arranged on the top or front thereof and a reflective coating layer **134** arranged on the bottom or rear thereof. The antireflective coating layer **132** is embedded with nano- and/or micro-particles **136** of one or more down-converting phosphors, while the reflective coating layer **134** is embedded with nano- and/or micro-particles **138** of one or more up-converting phosphors. As used herein, a “down-converting” phosphor is one that transforms high-energy photons to a lower energy, suitable for absorption by the semiconductor material, and an “up-converting” phosphor is one that transforms low-energy photons to a higher energy, suitable for absorption by the semiconductor material.

[0051] The down-converting phosphor particles **136** are embedded in the antireflective coating layer **132** with the correct refractive index to minimize emission away from the cell junction **12**. FIG. 7 is a graphical representation of the intensity of the excitation and resulting emission from an exemplary phosphor of photons of various wavelengths. In particular, the phosphor whose excitation and emission intensities are illustrated in FIG. 7 is calcium sulphide : europium (CaS : Eu). As shown therein, incident photons with wavelengths in the range of about 425-600 nm ($E = 2.9$ eV to 2 eV) is converted to an emission centered around 660 nm ($E = 1.88$ eV). It will be appreciated that although the incident photons in this example are on the lower edge of, but still within, the visible light spectrum, other phosphors are excited by photons in the ultraviolet portion of the spectrum and emit photons in the visible light spectrum, and that phosphors suitable for use in the antireflective coating layer **132** may be selected without undue experimentation by the Ordinary Artisan.

[0052] The up-converting phosphor particles **138** are embedded in the reflective coating layer **134** to maximize reflection of high-energy, long-wavelength photons back toward the cell junction **12**. FIG. 8 is a graphical representation of the intensity of the

emission resulting from an exemplary phosphor of photons of wavelengths between about 800 and 1400 nm (not shown). In particular, the phosphor whose excitation and emission intensities are illustrated in FIG. 7 is calcium sulphide : europium (CaS : Eu). As shown therein, incident photons with wavelengths in the range of about 800-1400 nm ($E=0.88$ to 1.55 eV) is converted to a broad emission centered around 510 nm ($E = 2.4$ eV). It will be appreciated that the phosphor whose excitation and emission properties are illustrated in FIG. 8 is merely an example, and that phosphors suitable for use in the reflective coating layer **134** may be selected without undue experimentation by the Ordinary Artisan.

[0053] FIGS. 9 and FIG. 10 are enlarged cross-sectional views of a portion of the cell **110** of FIG. 6 illustrating the improved operational efficiencies thereof. More particularly, FIG. 9 illustrates the use of down-conversion and up-conversion phosphor particles **136,138** to absorb and utilize photons from a greater portion of the electromagnetic spectrum, while FIG. 10 illustrates the use of improved surface geometry to capture a greater portion of the photons falling on the surface of the cell **110**.

[0054] As shown in FIG. 9, sunlight **50** falling on the top or front surface of the cell **110** includes an ultraviolet component **52**, a visible light component **54** and an infrared component **56**. Although reflection may be minimized through the use of the antireflective layer **134**, a portion **58** of the sunlight may be reflected from the surface of the cell **110**. It will be appreciated that the phosphor particles **136** embedded in the antireflective layer **132** may cause reflection of their own, but because the particles **136** are so small and make up a relatively small portion of the layer **132**, this effect is expected to be relatively small. Furthermore, although some of the reflected sunlight **58** will inevitably escape altogether, the improved surface geometry of the cell **110** will enable much of it to be captured elsewhere in the cell **110**, as described with regard to FIG. 10. Thus, additional reflectivity caused by the presence of the particles is more than counterbalanced by the improved surface geometry.

[0055] As the sunlight passes through the antireflective layer **132**, the down-conversion phosphor particles **136** embedded therein transform or convert high-energy photons, such as those in the ultraviolet component **52** of the sunlight, to lower energy photons that preferably match optional absorption in the semiconductor material. The resulting lower-energy photons **62** join the visible light component **64** and the infrared component **66** in passing into the semiconductor material. There, the photons whose energy is in the band gap for the material are absorbed, generating electron-hole pairs which are driven to the contacts by the built-in field. Thus, a greater amount of photons in the energy

range of visible light **64** passes into the semiconductor material for absorption therein than in the absence of the down-conversion particles **136**.

[0056] The semiconductor material is almost transparent to photons with energies lower than its band gap, such as infrared photons having long wavelengths. Most of this component **66** thus passes completely through the semiconductor material to the bottom or rear thereof, at which point they encounter the reflective layer **134** disposed there. Most or all of the infrared photons are then reflected back into the bottom or rear of the semiconductor material, but as they pass into or through portions of the reflective layer **134**, the up-conversion phosphor particles **138** embedded therein transform or convert low-energy photons, such as those in the infrared component **66**, to higher energy photons that preferably match optional absorption in the semiconductor material. It is the resulting higher-energy photons **76** that pass back into the semiconductor material. There, the photons whose energy is in the band gap for the material, which at this point is most of the photons, are absorbed, generating electron-hole pairs which are driven to the contacts by the built-in field. Thus, low-energy photons that would otherwise pass through the semiconductor material and be lost are instead converted to the energy range of visible light and pass once again into the semiconductor material for absorption therein.

[0057] The down-conversion and up-conversion of photons of high and low energy, respectively, is further enhanced through the use of the improved surface geometry. Sunlight **50** falling on the top or front the cell **110** may strike any of a variety of faces thereof, including a top or front of a contact, walls or plateaus **124,125** in a trench **120**, or even the bottom surface **122** of a trench **120**. Although reflection may be minimized through the use of the antireflective layer **134**, a portion **58** of the sunlight may be reflected, regardless of where it strikes. In this regard, it will once again be appreciated that the phosphor particles **136** embedded in the antireflective layer **132** may cause reflection of their own, but because the particles **136** are so small and make up a relatively small portion of the layer **132**, this effect is expected to be relatively small. Furthermore, although some of the reflected sunlight **58** will inevitably escape altogether, the improved surface geometry of the cell **110** will enable much of it to be captured elsewhere in the cell **110**, as described with regard to FIG. 10. Thus, additional reflectivity caused by the presence of the particles is more than counterbalanced by the improved surface geometry.

[0058] It will further be appreciated that an infinite range of possible strike locations and angles will be encountered in practice. Nonetheless, an exemplary angle and strike location are illustrated in FIG. 10 in order to illustrate some of the utility of the

arrangement of the present invention. In particular, the sunlight **50** in FIG. 10 is shown striking an upper wall **126** of a trench **120** of the cell **110**. A substantial portion **81** of this sunlight passes through the antireflective layer **132**, with high-energy photons being transformed or converted by phosphor particles **136** embedded therein and electron-hole pairs being generated by photons with energies in the band gap of the semiconductor material, as described above and illustrated in FIG. 9. A portion **82** of the sunlight, however, is reflected away from the wall **126** at an angle dependent, at least in substantial part, on the angle with which the sunlight **50** struck the upper wall **126**. In the illustrated example, this reflected portion **82** next strikes a lower wall **129** of the trench **120**. Once again, a substantial portion **83** of this reflected sunlight **82** passes through the antireflective layer **132**, with subsequent generation of electron-hole pairs as described previously. A portion **84**, however, is once again reflected away from the wall **129**. In the illustrated example, this reflected portion **84** next strikes the opposite lower wall **128** of the trench **120**. Yet again, a substantial portion **85** of this reflected sunlight **84** passes through the antireflective layer **132**, with subsequent generation of electron-hole pairs as described previously, and yet again, a portion **86** being reflected away from the wall **128**. In the illustrated example, this reflected portion **86** next strikes the lowermost surface **120** of the trench **120**. Yet still again, a substantial portion **87** of this reflected sunlight **86** passes through the antireflective layer **132**, with subsequent generation of electron-hole pairs as described previously. It will be appreciated that at this point, a remaining portion (not illustrated) of the reflected sunlight **86** would be reflected upward, but that it would likely encounter one of the lower walls of the trench **120** yet again. Indeed, it is possible, depending upon the angle and location of the original sunlight **50**, that almost the entirety of the original sunlight is eventually captured within the cell **110**, with each succeeding reflection creating yet another opportunity to capture a remaining portion of the reflected light.

[0059] As will be appreciated, some of the photons that pass into the semiconductor material will be of insufficient energy to be absorbed in the semiconductor material and may pass all the way through. These, in turn, may be reflected back upward by the reflective layer **134** at the bottom or rear of the cell **110**, as illustrated at the bottom of FIG. 10 and described and illustrated in more detail previously.

[0060] Referring again to FIG. 6, it will be appreciated that the dimensions of the various features of the trenches **120**, including those denoted with letters “a,” “b,” “c,” “d” and “e,” may be varied without departing from the scope of the present invention. Furthermore, the dimensions, shapes and relative sizes of the various structures shown in

FIGS. 5 and 6 are illustrative only, and may likewise be varied without departing from the scope of the present invention. For example, although the lowermost surface **122**, plateaus **124,125** and upper and lower walls **126,129** of the trenches **120** are illustrated as being parallel and perpendicular to one another, each such surface may be inclined or declined relative to the axes of the trench **120** without departing from the scope of the current invention.

[0061] An antireflective layer **132** in which down-conversion phosphor particles **136** are embedded may be applied to solar cells having other non-planar top or front surfaces as well. FIGS. 11 and 12 are schematic diagrams, in isometric and cross-sectional form, respectively, of an improved-efficiency solar cell **210** in accordance with a second preferred embodiment of the present invention. As shown therein, the solar cell **210** includes a junction **12** formed from an n-type semiconductor material **14** and a p-type semiconductor material **16** and a plurality of contacts **18,19** providing an electrical connection thereto. As with the solar cell **110** of FIGS. 5 and 6, the materials selected as the n- and p-type semiconductor materials **14,16** may be of any conventional combination.

[0062] The cell **210** includes a series of conventional trenches **220** opening upward, each having a lowermost surface **222** disposed below the top of the trench **220**. Like the cell **110** of FIGS. 5 and 6, the cell **210** of FIGS. 11 and 12 also includes an antireflective coating layer **132** arranged on the top or front thereof and a reflective coating layer **134** arranged on the bottom or rear thereof. The antireflective coating layer **132** is embedded with nano- and/or micro-particles **136** of one or more down-converting phosphors, while the reflective coating layer **134** is embedded with nano- and/or micro-particles **138** of one or more up-converting phosphors. Although not as effective in capturing reflected sunlight as the cell **110** having the improved surface geometry shown in FIGS. 5 and 6, the cooperation of the corrugated trenches **220** with the antireflective and reflective layers **132,134** having, respectively, down-converting and up-converting phosphor particles embedded therein nonetheless represents a significant improvement in efficiency over prior art solar cells **10,11**.

[0063] Referring again to FIG. 12, it will be appreciated that the dimensions of the various features of the trenches **220**, including those denoted with letters “a,” “e” and “h,” may be varied without departing from the scope of the present invention. Furthermore, the dimensions, shapes and relative sizes of the various structures shown in FIGS. 11 and 12 are illustrative only, and may likewise be varied without departing from the scope of the present invention. For example, although the lowermost surfaces **222** of the trenches **220** are illustrated as being parallel to one another, each such surface may be inclined or declined

relative to the axes of the trench **220** without departing from the scope of the current invention.

[0064] The improved surface geometry may also be utilized without the antireflective down-conversion layer **132**, the reflective up-conversion layer **134**, or both, while still gaining some benefit from the improved amount of sunlight captured thereby. FIGS. 13 and 14 are schematic diagrams, in isometric and cross-sectional form, respectively, of a solar cell **310** having only the optically designed surface for improved angle-independent absorption of light in accordance with a third preferred embodiment of the present invention. As shown therein, the solar cell **310** again includes a junction **12** formed from an n-type semiconductor material **14** and a p-type semiconductor material **16** and a plurality of contacts **18,19** providing an electrical connection thereto. As with the previous solar cells **110,210**, the materials selected as the n- and p-type semiconductor materials **14,16** may be of any conventional combination.

[0065] Similar to the cell **110** of FIGS. 5 and 6, the cell **310** of FIGS. 13 and 14 includes a series of stepped trenches **120** opening upward, each having a lowermost surface **122** and at least one plateau **124,125** elevated above the lowermost surface **122** but disposed below the top of the trench **120**. In an illustrative example, sunlight **50** falling on an upper wall of the trench is reflected back and forth as more and more of it is gradually absorbed into the junction area, similar to the reflection and absorption of light described with regard to FIG. 10. Again, the arrangement of stepped trenches **120** provides significant improvement with regard to scattering and hence absorption of light with minimal dependence on the radiation's incident angle. Known surface geometries, such as that illustrated in FIG. 4, are able to trap some of the photons that would otherwise be reflected back away from the cell **10** through the use of the walls of the trench **20**, which block the upward path of some of the reflected sunlight. However, photons from light falling on central portions of the trenches **20** of the conventional cell **10** of FIG. 4 are lost, while photons from light falling on central portions of the trenches **120** of the solar cell **310** of FIG. 13 fall between the adjacent plateaus **124,125** toward the lowermost surface **122** of the trench **120**. Some fall on the lower walls of the trench **120**, while others reach the lowermost surface **122** directly. In either case, a portion of the photons are absorbed, and an ever-dwindling portion are reflected, where they are likely to reach yet another surface within the trench **120**.

[0066] Referring again to FIG. 14, it will be appreciated that the dimensions of the various features of the trenches **120**, including those denoted with letters "a," "b," "c," "d" and "e," may be varied without departing from the scope of the present invention.

Furthermore, the dimensions, shapes and relative sizes of the various structures shown in FIGS. 13 and 14 are illustrative only, and may likewise be varied without departing from the scope of the present invention. For example, although the lowermost surface **122**, plateaus **124,125** and upper and lower walls **126,129** of the trenches **120** are illustrated as being parallel and perpendicular to one another, each such surface may be inclined or declined relative to the axes of the trench **120** without departing from the scope of the current invention.

[0067] In at least one embodiment, an additional plateau (not illustrated) may be disposed in any of the trenches **120** between either or both of the first and second plateaus **124,125** and the top of the trench **120**, between either or both of the first and second plateaus **124,125** and the lowermost surface **122**, or both.

[0068] FIGS. 15 and 16 are schematic diagrams, in isometric and cross-sectional form, respectively, of a solar cell **410** having an improved rear or bottom surface geometry in accordance with a fourth preferred embodiment of the present invention. In particular, the solar cell **410** of FIGS. 15 and 16 is similar to that of FIGS. 13 and 14, but whose bottom or rear includes a series of hollows **440** opening downward, each having an upper surface **442**. These hollows **440**, which may be created via etching during the manufacturing process, may optionally be utilized to minimize carrier travel path to some or all of the contacts **19**, to minimize attenuation of long wavelength light used for up-conversion at the back of the cell, or both. The lower surface has a large surface-to-volume ratio, which, in turn, results in maximizing the volume of the depletion region at the p-n junction **12**. Carriers generated at the p-n junction **12** are driven by the built in potential towards the contacts **19**. Since the solar cell current is proportional to the volume of the depletion region, this design will assist in enhancing the efficiency of the cell **410**.

[0069] Referring again to FIG. 14, it will be appreciated that the dimensions of the various features of the trenches **120**, including those denoted with letters “a,” “b,” “c,” “d,” “e,” “f” and “g,” may be varied without departing from the scope of the present invention. Furthermore, the dimensions, shapes and relative sizes of the various structures shown in FIGS. 15 and 16 are illustrative only, and may likewise be varied without departing from the scope of the present invention. For example, although the lowermost surface **122**, plateaus **124,125** and upper and lower walls **126,129** of the trenches **120** are illustrated as being parallel and perpendicular to one another, each such surface may be inclined or declined relative to the axes of the trench **120** without departing from the scope of the current invention.

[0070] It will be further appreciated that the actual surface geometry may have a shape and profile that are determined by available algorithms and are preferably based on optical design parameters such as the refractive index of the solar cell. The surface may be fabricated using conventional diffractive optics techniques, including nano-imprinting. Furthermore, because reflection is minimized, the need for a mechanical tracking system to keep the cell directed toward the sun may be obviated or reduced.

[0071] In another feature, the capture of light by the cell **110,210,310,410** may be further improved by etching cavities under the surface.

[0072] FIG. 17 is a schematic diagram, in isometric form, of a solar cell **510** having another optically designed surface for improved angle-independent absorption of light in accordance with a fifth preferred embodiment of the present invention. In particular, the solar cell **510** of FIG. 17 is similar to that of FIGS. 13 and 14, but whose trenches **520** have a hexagonal cross-section or profile. As will be appreciated, direct or reflected sunlight entering the trenches **520** will be reflected differently than that entering the stepped trenches **120** of the solar cell **310** of FIGS. 13 and 14, and light that finds its way into these trenches **520** may be even less likely to escape than light entering the stepped trenches **120**.

[0073] It will also be appreciated that although not illustrated, down- and up-conversion layers **132,134** of the type described previously may be included with the solar cell **510** of FIG. 17 in at least some embodiments, and furthermore that hollows **440** optionally may be included in the bottom or rear surface as well. Still further, it will be appreciated that the dimensions of the various features of the trenches **520** may be varied without departing from the scope of the present invention, and that the dimensions, shapes and relative sizes of the various structures shown in FIG. 17 are illustrative only, and may likewise be varied without departing from the scope of the present invention.

[0074] FIG. 18 is a schematic diagram, in isometric form, of a solar cell **610** having another optically designed surface for improved angle-independent absorption of light in accordance with a sixth preferred embodiment of the present invention. In particular, the solar cell **610** of FIG. 18 is similar to that of FIG. 17, but whose hexagonal trenches **620** are positioned deeper beneath the top or front surface and are connected to the surface via a narrower passage **621**. As will be appreciated, direct or reflected sunlight entering the trenches **620** will be reflected differently than that entering the stepped trenches **120** of the solar cell **310** of FIGS. 13 and 14, and light that finds its way into these trenches **620** may be even less likely to escape than light entering the stepped trenches **120**.

[0075] It will also be appreciated that although not illustrated, down- and up-conversion layers **132,134** of the type described previously may be included with the solar cell **610** of FIG. 18 in at least some embodiments, and furthermore that hollows **440** optionally may be included in the bottom or rear surface as well. Still further, it will be appreciated that the dimensions of the various features of the trenches **620** may be varied without departing from the scope of the present invention, and that the dimensions, shapes and relative sizes of the various structures shown in FIG. 18 are illustrative only, and may likewise be varied without departing from the scope of the present invention.

[0076] Based on the foregoing information, it is readily understood by those persons skilled in the art that the present invention is susceptible of broad utility and application. Many embodiments and adaptations of the present invention other than those specifically described herein, as well as many variations, modifications, and equivalent arrangements, will be apparent from or reasonably suggested by the present invention and the foregoing descriptions thereof, without departing from the substance or scope of the present invention.

[0077] Accordingly, while the present invention has been described herein in detail in relation to its preferred embodiment, it is to be understood that this disclosure is only illustrative and exemplary of the present invention and is made merely for the purpose of providing a full and enabling disclosure of the invention. The foregoing disclosure is not intended to be construed to limit the present invention or otherwise exclude any such other embodiments, adaptations, variations, modifications or equivalent arrangements; the present invention being limited only by the claims appended hereto and the equivalents thereof. Although specific terms are employed herein, they are used in a generic and descriptive sense only and not for the purpose of limitation.

CLAIMS

What is claimed is:

1. A photovoltaic cell comprising:
a junction formed from an n-type semiconductor material and a p-type semiconductor material and having a light-incident side and an opposite side;
a trench, opening toward the light-incident side of the junction, for trapping reflected light;
a first photon conversion layer that converts photons from a higher energy to a lower energy suitable for absorption by the semiconductor material; and
a second photon conversion layer that converts photons from a lower energy to a higher energy suitable for absorption by the semiconductor material.
2. The photovoltaic cell of Claim 1, wherein the trench includes a top, a lowermost surface, and at least one plateau elevated above the lowermost surface but disposed below the top of the trench.
3. The photovoltaic cell of Claim 2, wherein the trench further includes an additional plateau disposed between the at least one plateau and the top of the trench.
4. The photovoltaic cell of Claim 2, wherein the trench further includes an additional plateau disposed between the lowermost surface and the at least one plateau.
5. The photovoltaic cell of Claim 2, wherein the at least one plateau is inclined or declined relative to other surfaces of the trench.
6. The photovoltaic cell of Claim 2, wherein the lowermost surface is inclined or declined relative to other surfaces of the trench.
7. The photovoltaic cell of Claim 1, wherein the second photon conversion layer is arranged on the opposite side of the junction.
8. The photovoltaic cell of Claim 7, wherein the first photon conversion layer is arranged on the light-incident side of the junction.

9. The photovoltaic cell of Claim 8, wherein the first photon conversion layer is an antireflective coating layer.
10. The photovoltaic cell of Claim 7, wherein the second photon conversion layer includes phosphor particles embedded therein, the phosphor particles selected to convert photons passing through the junction unabsorbed from a lower energy to a higher energy.
11. The photovoltaic cell of Claim 10, wherein the phosphor particles are nano-particles.
12. The photovoltaic cell of Claim 10, wherein the phosphor particles are micro-particles.
13. The photovoltaic cell of Claim 7, wherein the second photon conversion layer is a reflective coating layer.
14. The photovoltaic cell of Claim 1, wherein the composition of the first photon conversion layer is selected to optimize subsequent absorption of the lower-energy photons, converted thereby, by the semiconductor material.
15. The photovoltaic cell of Claim 1, wherein the composition of the second photon conversion layer is selected to optimize subsequent absorption of the higher-energy photons, converted thereby, by the semiconductor material.
16. The photovoltaic cell of Claim 1, wherein an upper wall of the trench is inclined or declined relative to other surfaces of the trench.
17. The photovoltaic cell of Claim 1, wherein a lower wall of the trench is inclined or declined relative to other surfaces of the trench.
18. The photovoltaic cell of Claim 1, further comprising a hollow, opening toward the opposite side of the junction, for minimizing carrier travel path to one or more contacts, for minimizing attenuation of long wavelength light used for up-conversion, or both.
19. The photovoltaic cell of Claim 18, further comprising an electrical contact disposed in the hollow.

20. The photovoltaic cell of Claim 18, wherein the second photon conversion layer is arranged at least partially in the hollow.
21. The photovoltaic cell of Claim 1, wherein at least a portion of the cross-section or profile of the trench is hexagonal in shape.
22. The photovoltaic cell of Claim 21, wherein the hexagonally-shaped portion of the trench profile opens directly to the light-incident side of the junction.
23. The photovoltaic cell of Claim 21, wherein the hexagonally-shaped portion of the trench profile opens to the light-incident side of the junction via a passage that is narrower than the width of the hexagonally-shaped portion.
24. A photovoltaic cell comprising:
a junction formed from an n-type semiconductor material and a p-type semiconductor material and having a light-incident side and an opposite side; and
a stepped trench, opening toward the light-incident side of the junction, for trapping reflected light, including:
a top,
a lowermost surface, and
at least one plateau elevated above the lowermost surface but disposed below the top of the stepped trench.
25. The photovoltaic cell of Claim 24, wherein the stepped trench further includes an additional plateau disposed between the at least one plateau and the top of the stepped trench.
26. The photovoltaic cell of Claim 24, wherein the stepped trench further includes an additional plateau disposed between the lowermost surface and the at least one plateau.
27. The photovoltaic cell of Claim 24, further including a photon conversion layer.
28. The photovoltaic cell of Claim 27, wherein the photon conversion layer is arranged on the light-incident side of the junction.

29. The photovoltaic cell of Claim 27, wherein the photon conversion layer is a first photon conversion layer, and wherein a second photon conversion layer is arranged on the opposite side of the junction.
30. The photovoltaic cell of Claim 29, wherein the second photon conversion layer is arranged on the opposite side of the junction.
31. The photovoltaic cell of Claim 29, wherein the first photon conversion layer is arranged on the light-incident side of the junction.
32. The photovoltaic cell of Claim 29, wherein the first photon conversion layer is an antireflective coating layer.
33. The photovoltaic cell of Claim 29, wherein the second photon conversion layer includes phosphor particles embedded therein, the phosphor particles selected to convert photons passing through the junction unabsorbed from a lower energy to a higher energy.
34. The photovoltaic cell of Claim 33, wherein the phosphor particles are nano-particles.
35. The photovoltaic cell of Claim 33, wherein the phosphor particles are micro-particles.
36. The photovoltaic cell of Claim 29, wherein the second photon conversion layer is a reflective coating layer.
37. The photovoltaic cell of Claim 29, wherein the composition of the first photon conversion layer is selected to optimize subsequent absorption of lower-energy photons, converted by the first photon conversion layer to a higher energy, by the semiconductor material.
38. The photovoltaic cell of Claim 29, wherein the composition of the second photon conversion layer is selected to optimize subsequent absorption of higher-energy photons, converted by the second photon conversion layer to a lower energy, by the semiconductor material.

39. The photovoltaic cell of Claim 24, wherein the at least one plateau is inclined or declined relative to other surfaces of the stepped trench.
40. The photovoltaic cell of Claim 24, wherein the lowermost surface is inclined or declined relative to other surfaces of the stepped trench.
41. The photovoltaic cell of Claim 24, wherein an upper wall of the stepped trench is inclined or declined relative to other surfaces of the stepped trench.
42. The photovoltaic cell of Claim 24, wherein a lower wall of the stepped trench is inclined or declined relative to other surfaces of the stepped trench.
43. The photovoltaic cell of Claim 24, further comprising a hollow, opening toward the opposite side of the junction, for minimizing carrier travel path to one or more contacts, for minimizing attenuation of long wavelength light used for up-conversion, or both.
44. The photovoltaic cell of Claim 43, further comprising an electrical contact disposed in the hollow.
45. The photovoltaic cell of Claim 43, wherein a photon conversion layer is arranged at least partially in the hollow.
46. A photovoltaic cell comprising:
a junction formed from an n-type semiconductor material and a p-type semiconductor material and having a light-incident side and an opposite side; and
a stepped trench, opening toward the light-incident side of the junction, for trapping reflected light, wherein the cross-section or profile of the stepped trench includes:
a top,
a lowermost boundary, and
at least one plateau elevated above the lowermost boundary but disposed below the top.

47. The photovoltaic cell of Claim 46, wherein the stepped trench further includes an additional plateau disposed between the at least one plateau and the top of the stepped trench.
48. The photovoltaic cell of Claim 46, wherein the stepped trench further includes an additional plateau disposed between the lowermost boundary and the at least one plateau.
49. The photovoltaic cell of Claim 46, further including a photon conversion layer.
50. The photovoltaic cell of Claim 49, wherein the photon conversion layer is arranged on the light-incident side of the junction.
51. The photovoltaic cell of Claim 49, wherein the photon conversion layer is a first photon conversion layer, and wherein a second photon conversion layer is arranged on the opposite side of the junction.
52. The photovoltaic cell of Claim 51, wherein the first photon conversion layer is an antireflective coating layer.
53. The photovoltaic cell of Claim 51, wherein the second photon conversion layer includes phosphor particles embedded therein, the phosphor particles selected to convert photons passing through the junction unabsorbed from a lower energy to a higher energy.
54. The photovoltaic cell of Claim 53, wherein the phosphor particles are nano-particles.
55. The photovoltaic cell of Claim 53, wherein the phosphor particles are micro-particles.
56. The photovoltaic cell of Claim 51, wherein the second photon conversion layer is a reflective coating layer.
57. The photovoltaic cell of Claim 51, wherein the composition of the first photon conversion layer is selected to optimize subsequent absorption of lower-energy photons, converted by the first photon conversion layer to a higher energy, by the semiconductor material.

58. The photovoltaic cell of Claim 51, wherein the composition of the second photon conversion layer is selected to optimize subsequent absorption of higher-energy photons, converted by the second photon conversion layer to a lower energy, by the semiconductor material.
59. The photovoltaic cell of Claim 46, wherein the at least one plateau is inclined or declined relative to other surfaces of the stepped trench.
60. The photovoltaic cell of Claim 46, wherein the lowermost surface is inclined or declined relative to other surfaces of the stepped trench.
61. The photovoltaic cell of Claim 46, wherein an upper wall of the stepped trench is inclined or declined relative to other surfaces of the stepped trench.
62. The photovoltaic cell of Claim 46, wherein a lower wall of the stepped trench is inclined or declined relative to other surfaces of the stepped trench.
63. The photovoltaic cell of Claim 46, further comprising a hollow, opening toward the opposite side of the junction, for minimizing carrier travel path to one or more contacts, for minimizing attenuation of long wavelength light used for up-conversion, or both.
64. The photovoltaic cell of Claim 63, further comprising an electrical contact disposed in the hollow.
65. The photovoltaic cell of Claim 63, wherein a photon conversion layer is arranged at least partially in the hollow.
66. A photovoltaic cell comprising:
a junction formed from an n-type semiconductor material and a p-type semiconductor material and having a light-incident side and an opposite side;
a trench, opening toward the light-incident side of the junction, for trapping reflected light; and
a reflective layer, disposed on the side of the junction, opposite the light-incident side of the junction, that includes phosphor particles that convert photons which

pass through the semiconductor material, without being absorbed, from a lower energy to a higher energy suitable for subsequent absorption by the semiconductor material.

67. The photovoltaic cell of Claim 66, wherein the trench includes a top, a lowermost surface, and at least one plateau elevated above the lowermost surface but disposed below the top of the trench.
68. The photovoltaic cell of Claim 67, wherein the trench further includes an additional plateau disposed between the at least one plateau and the top of the trench.
69. The photovoltaic cell of Claim 67, wherein the trench further includes an additional plateau disposed between the lowermost surface and the at least one plateau.
70. The photovoltaic cell of Claim 67, wherein the at least one plateau is inclined or declined relative to other surfaces of the trench.
71. The photovoltaic cell of Claim 67, wherein the lowermost surface is inclined or declined relative to other surfaces of the trench.
72. The photovoltaic cell of Claim 67, wherein an upper wall of the trench is inclined or declined relative to other surfaces of the trench.
73. The photovoltaic cell of Claim 67, wherein a lower wall of the trench is inclined or declined relative to other surfaces of the trench.
74. The photovoltaic cell of Claim 66, wherein the phosphor particles are nano-particles.
75. The photovoltaic cell of Claim 66, wherein the phosphor particles are micro-particles.
76. The photovoltaic cell of Claim 66, wherein the composition of the relective layer is selected to optimize subsequent absorption of the higher-energy photons, converted thereby, by the semiconductor material.

77. The photovoltaic cell of Claim 66, further comprising a hollow, opening toward the opposite side of the junction, for minimizing carrier travel path to one or more contacts, for minimizing attenuation of long wavelength light used for up-conversion, or both.
78. The photovoltaic cell of Claim 77, further comprising an electrical contact disposed in the hollow.
79. The photovoltaic cell of Claim 77, wherein the relective layer is arranged at least partially in the hollow.
80. The photovoltaic cell of Claim 66, wherein at least a portion of the cross-section or profile of the trench is hexagonal in shape.
81. The photovoltaic cell of Claim 80, wherein the hexagonally-shaped portion of the trench profile opens directly to the light-incident side of the junction.
82. The photovoltaic cell of Claim 80, wherein the hexagonally-shaped portion of the trench profile opens to the light-incident side of the junction via a passage that is narrower than the width of the hexagonally-shaped portion.
83. A photovoltaic cell comprising:
a junction formed from an n-type semiconductor material and a p-type semiconductor material and having a light-incident side and an opposite side; and
a trench, opening toward the light-incident side of the junction, for trapping reflected light, wherein at least a portion of the cross-section or profile of the trench is hexagonal in shape.
84. The photovoltaic cell of Claim 83, wherein the hexagonally-shaped portion of the trench profile opens directly to the light-incident side of the junction.
85. The photovoltaic cell of Claim 83, wherein the hexagonally-shaped portion of the trench profile opens to the light-incident side of the junction via a passage that is narrower than the width of the hexagonally-shaped portion.

86. The photovoltaic cell of Claim 83, further including a photon conversion layer.
87. The photovoltaic cell of Claim 86, wherein the photon conversion layer is arranged on the light-incident side of the junction.
88. The photovoltaic cell of Claim 86, wherein the photon conversion layer is a first photon conversion layer, and wherein a second photon conversion layer is arranged on a side of the junction that is opposite the light-incident side.
89. The photovoltaic cell of Claim 88, wherein the first photon conversion layer is an antireflective coating layer.
90. The photovoltaic cell of Claim 88, wherein the second photon conversion layer includes phosphor particles embedded therein, the phosphor particles selected to convert photons passing through the junction unabsorbed from a lower energy to a higher energy.
91. The photovoltaic cell of Claim 90, wherein the phosphor particles are nano-particles.
92. The photovoltaic cell of Claim 90, wherein the phosphor particles are micro-particles.
93. The photovoltaic cell of Claim 88, wherein the second photon conversion layer is a reflective coating layer.
94. The photovoltaic cell of Claim 88, wherein the composition of the first photon conversion layer is selected to optimize subsequent absorption of the lower-energy photons, converted thereby, by the semiconductor material.
95. The photovoltaic cell of Claim 88, wherein the composition of the second photon conversion layer is selected to optimize subsequent absorption of the higher-energy photons, converted thereby, by the semiconductor material.
96. The photovoltaic cell of Claim 83, further comprising a hollow, opening toward a side of the junction that is opposite the light-incident side, for minimizing carrier travel path to

one or more contacts, for minimizing attenuation of long wavelength light used for up-conversion, or both.

97. The photovoltaic cell of Claim 96, further comprising an electrical contact disposed in the hollow.

98. The photovoltaic cell of Claim 96, wherein a photon conversion layer is arranged at least partially in the hollow.

10

prior art

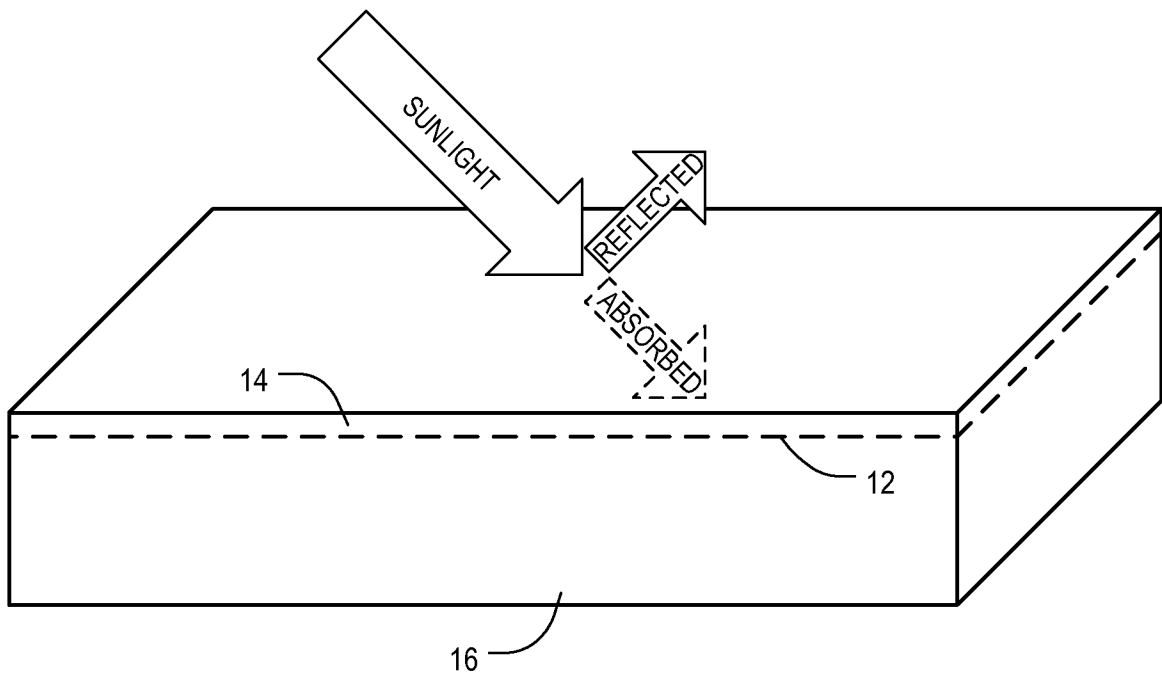

FIG. 1

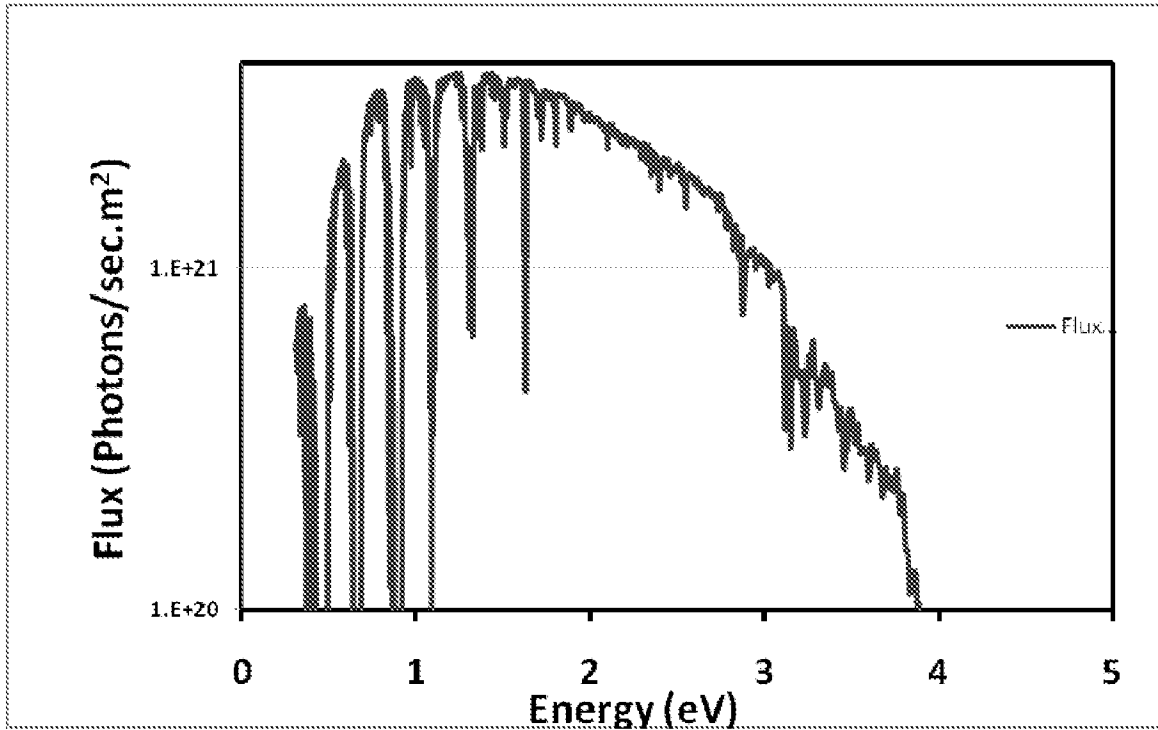

FIG. 2

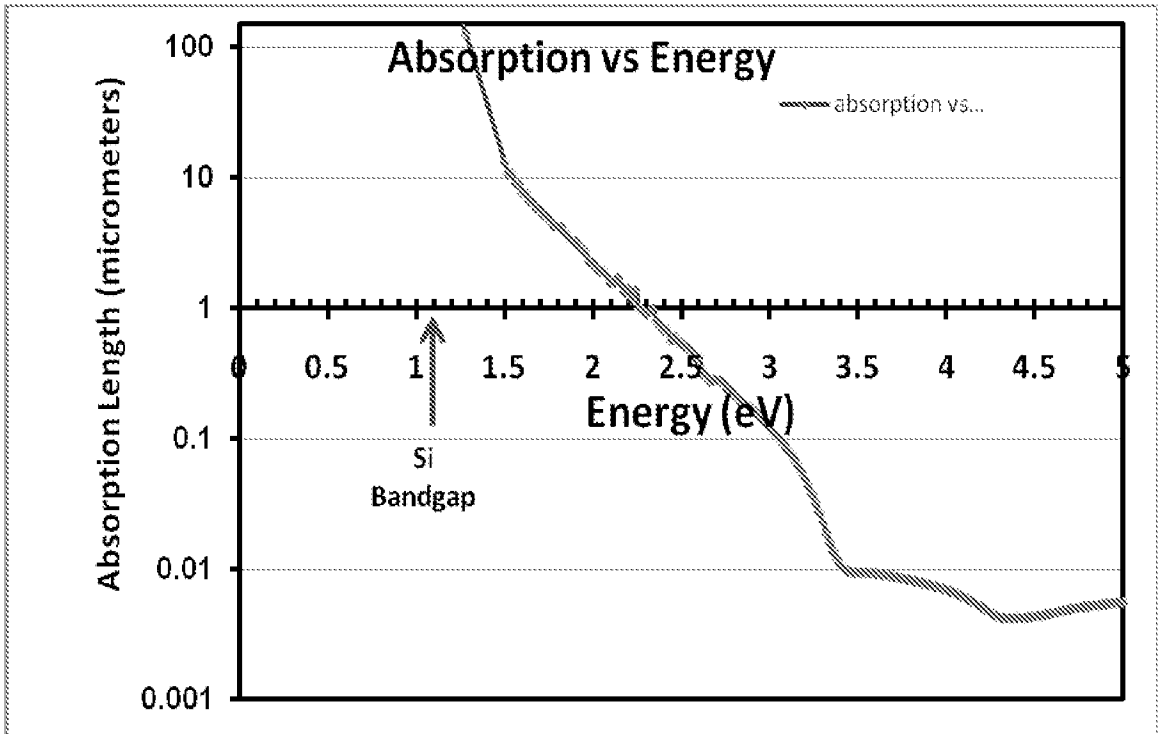

FIG. 3

11

prior art

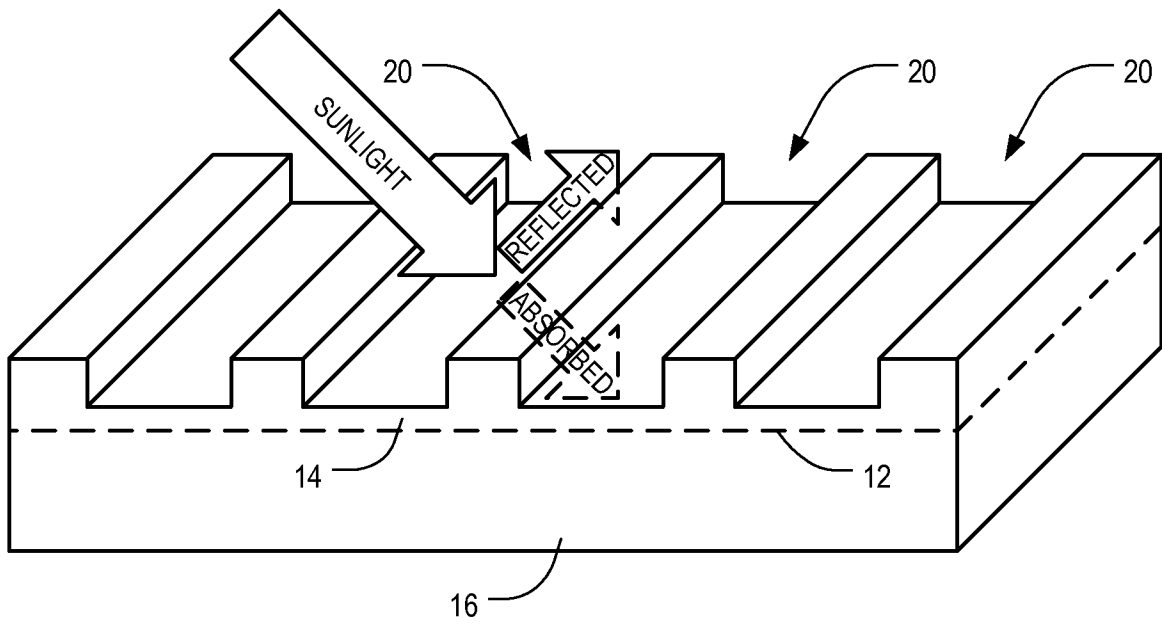

FIG. 4

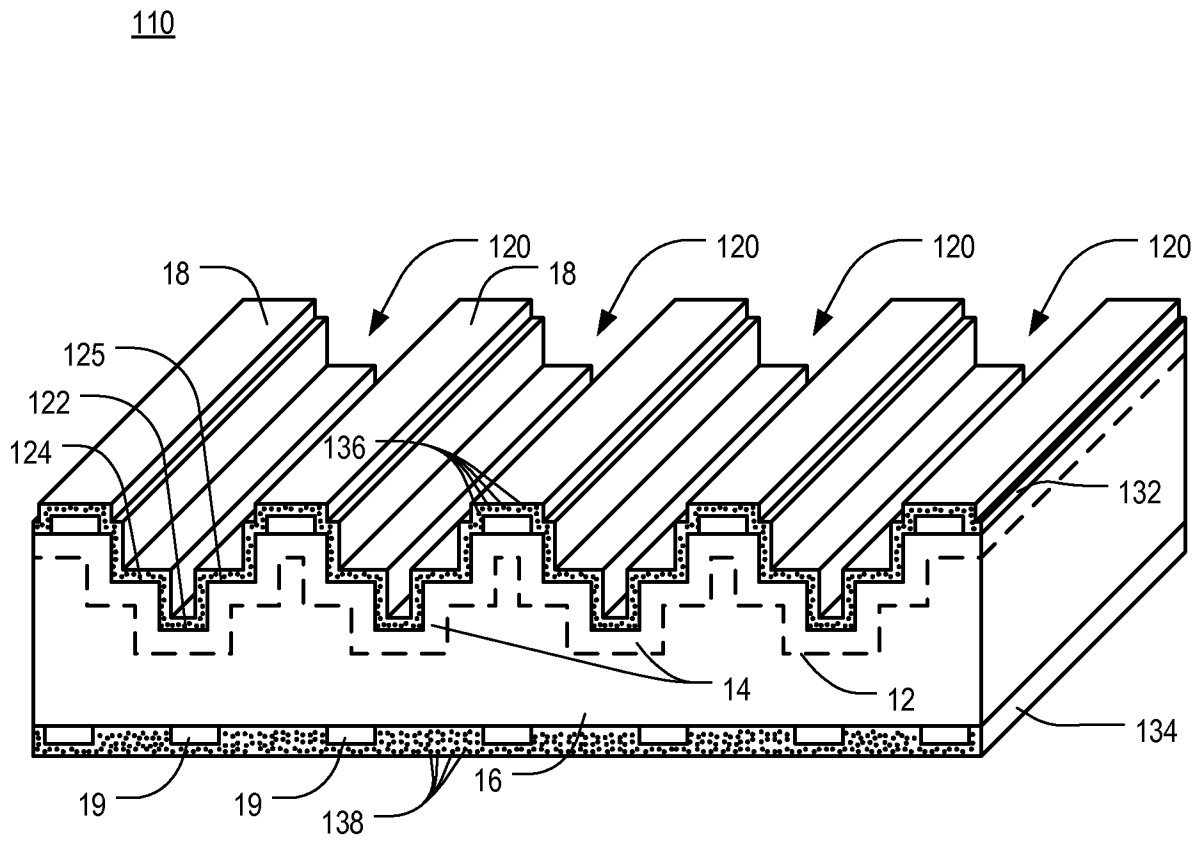

FIG. 5

110

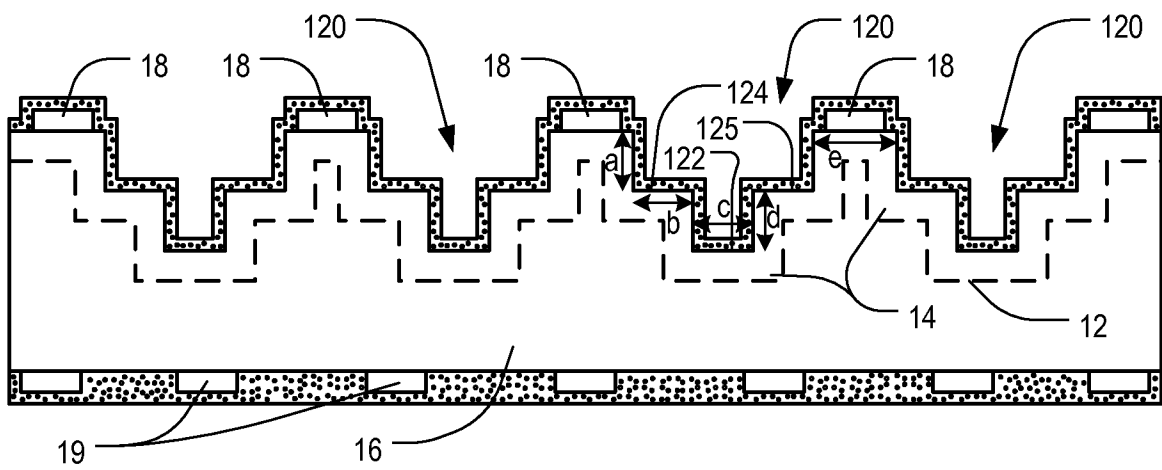

FIG. 6

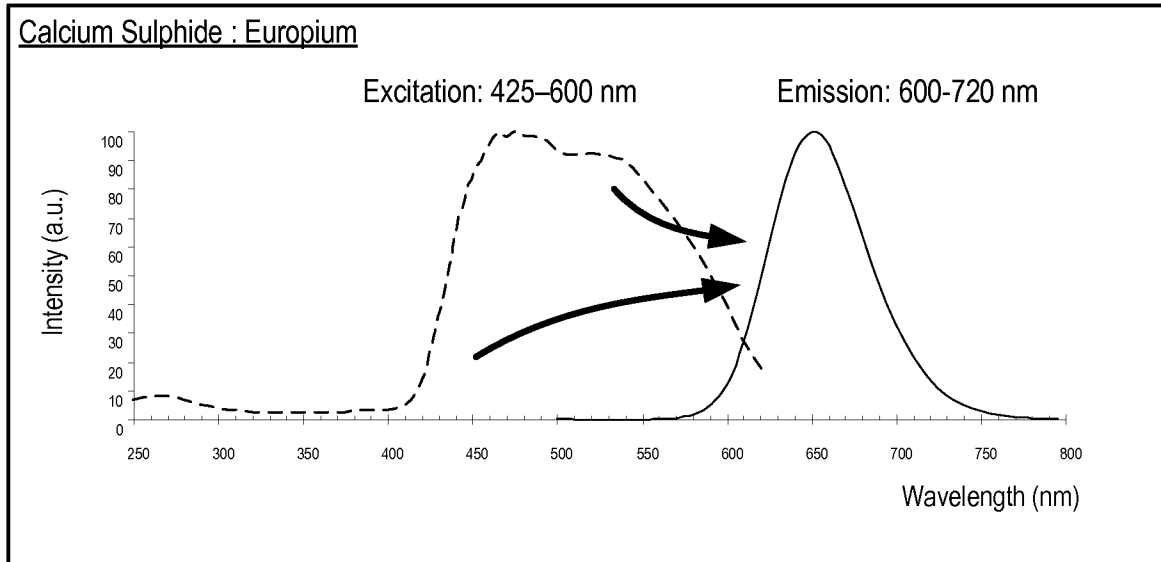

FIG. 7

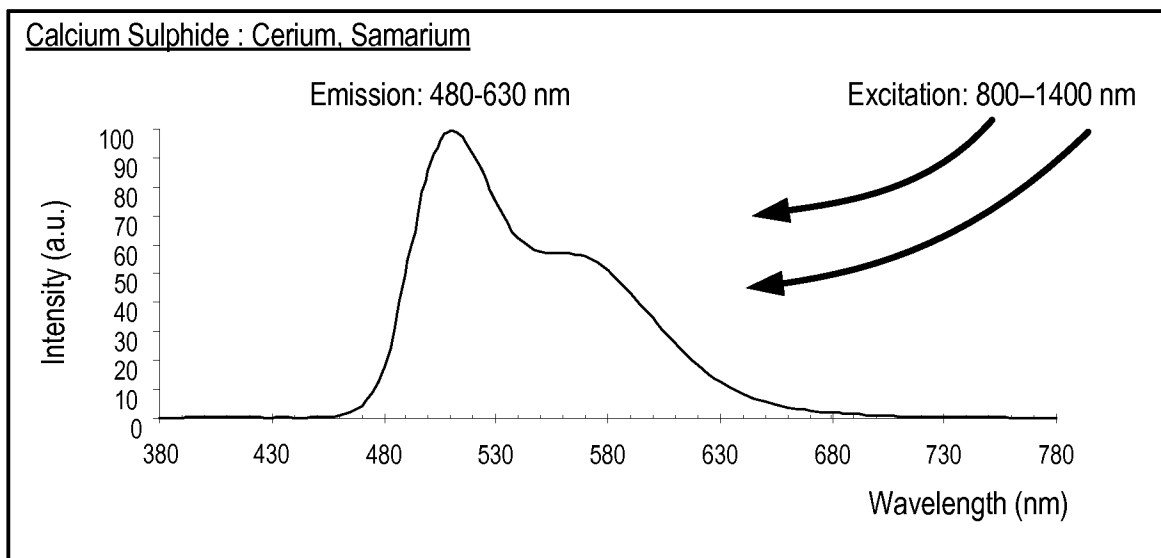

FIG. 8

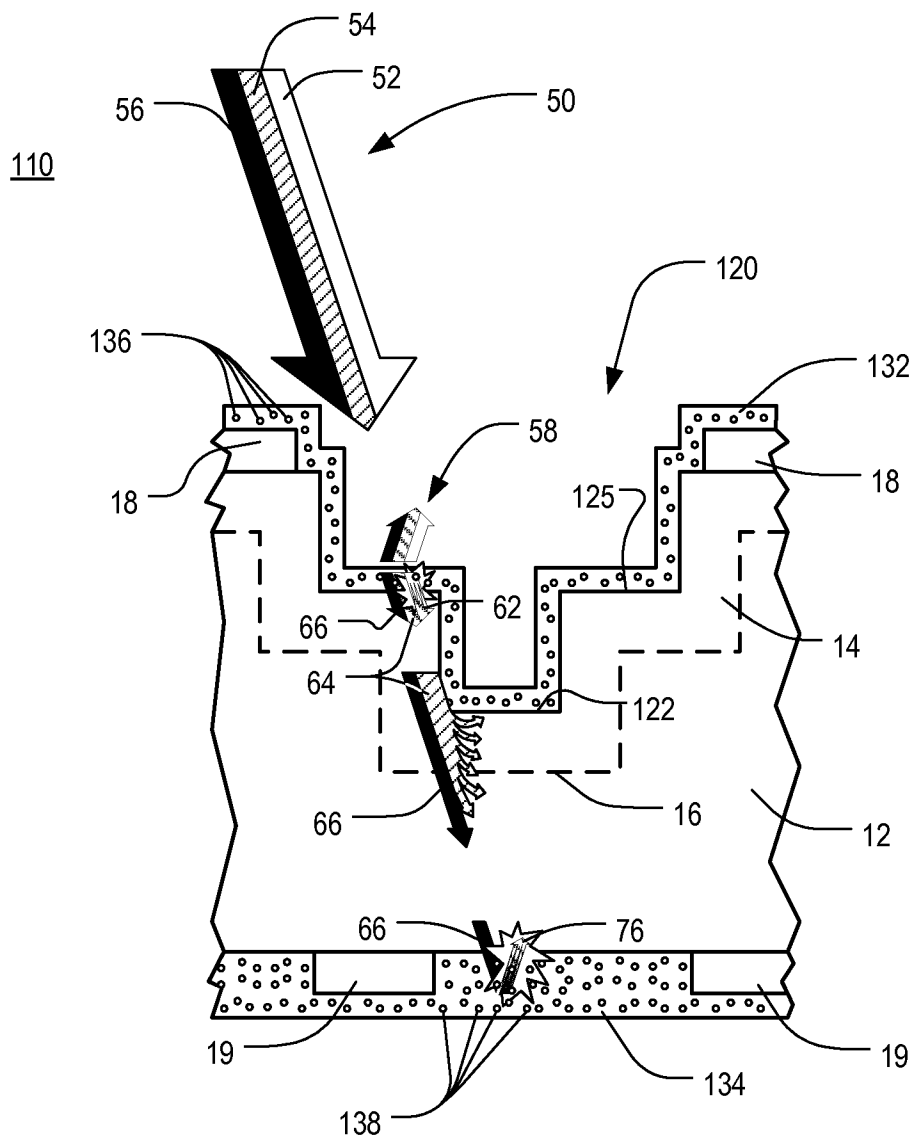

FIG. 9

110

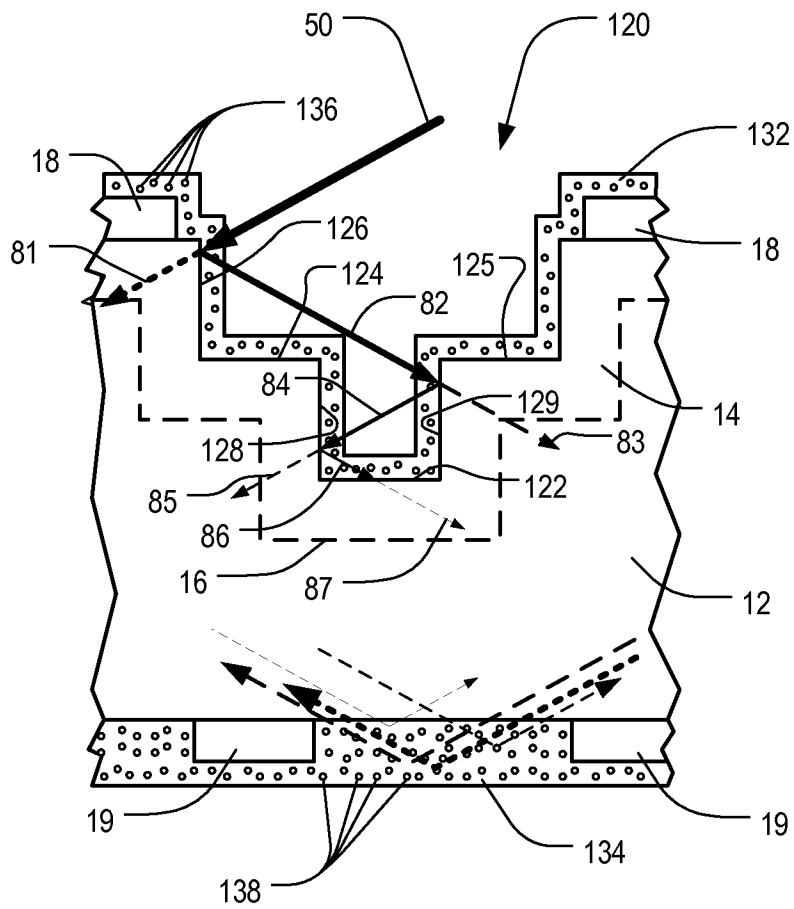

FIG. 10

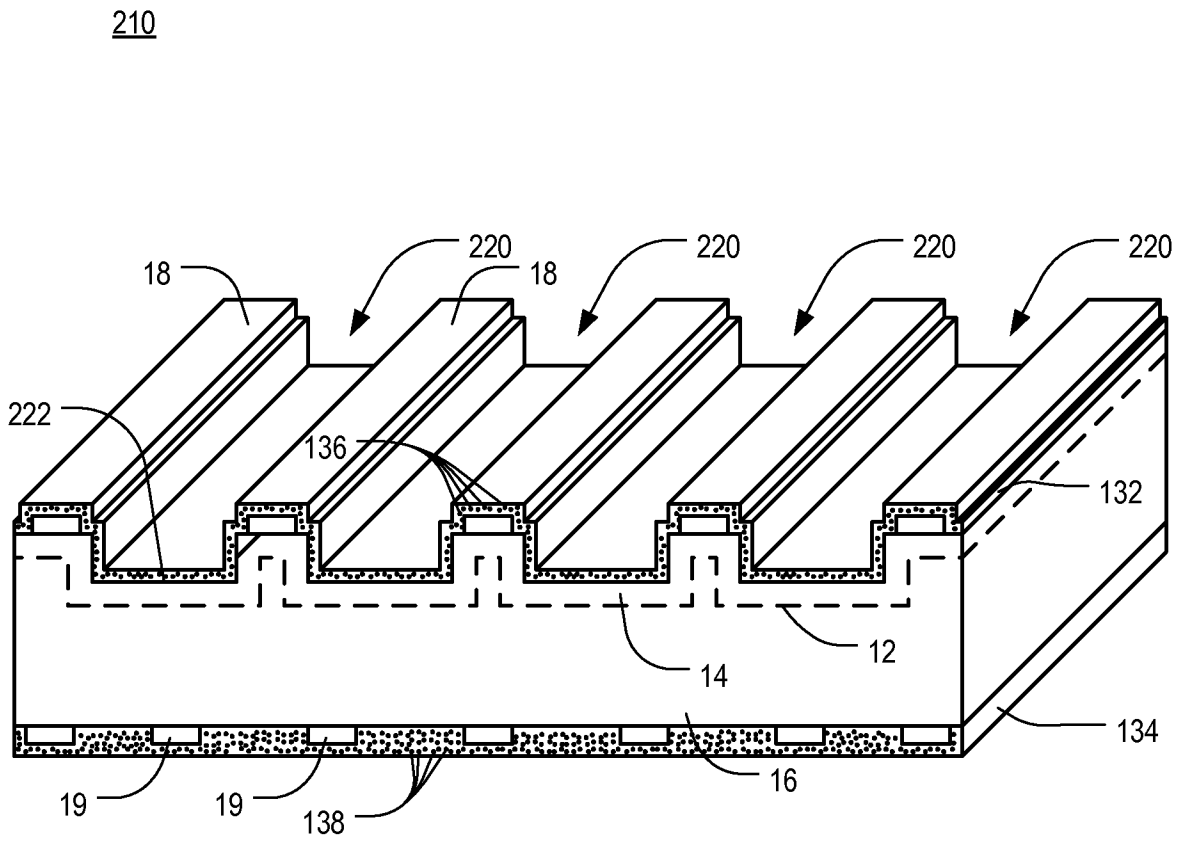

FIG. 11

220

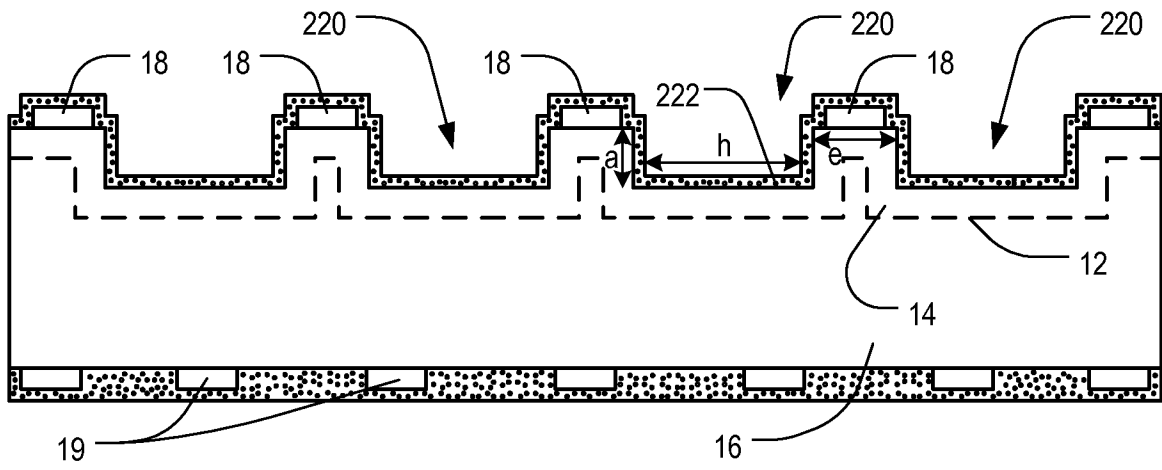

FIG. 12

310

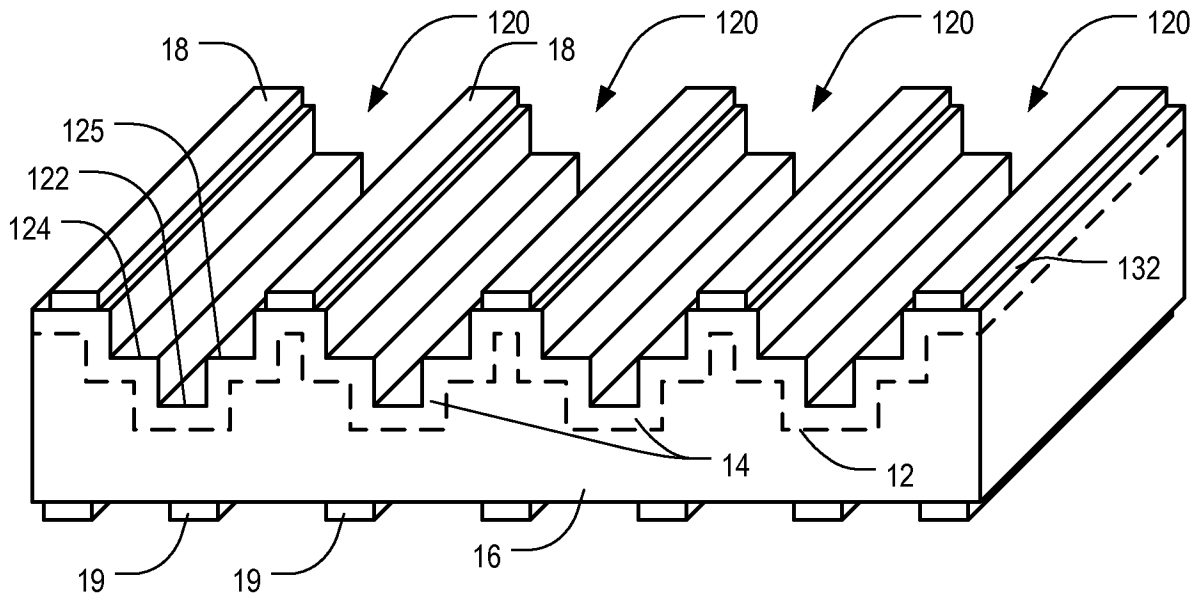

FIG. 13

410

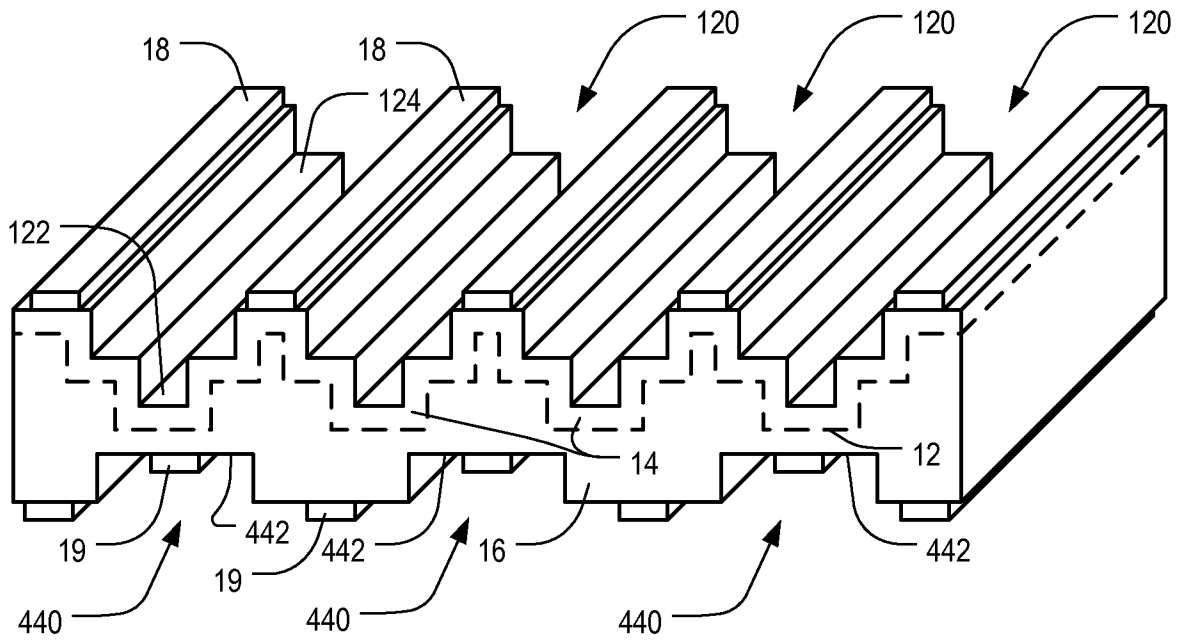

FIG. 15

410

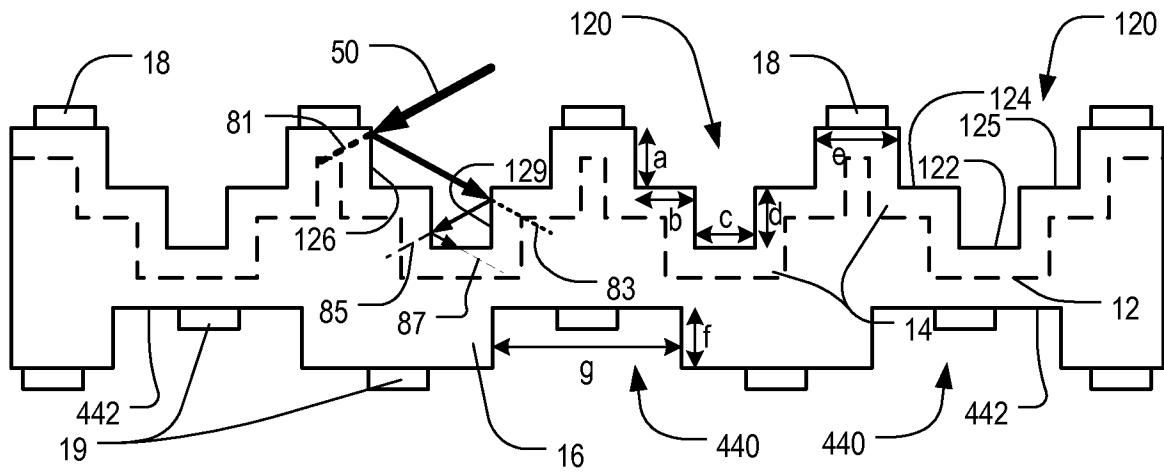

FIG. 16

510

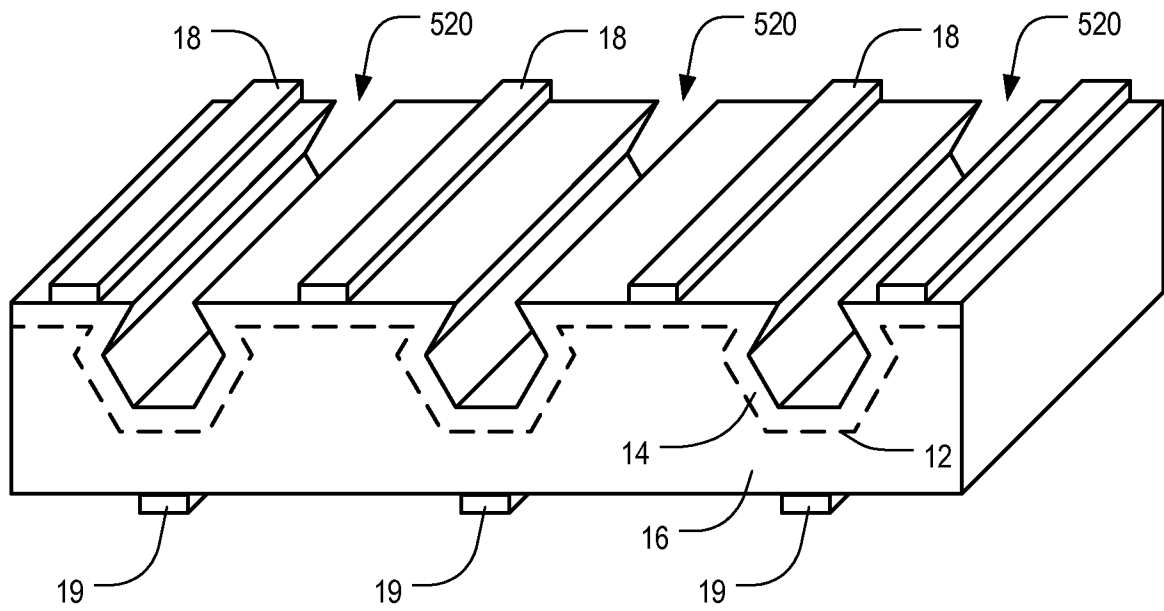

FIG. 17

610

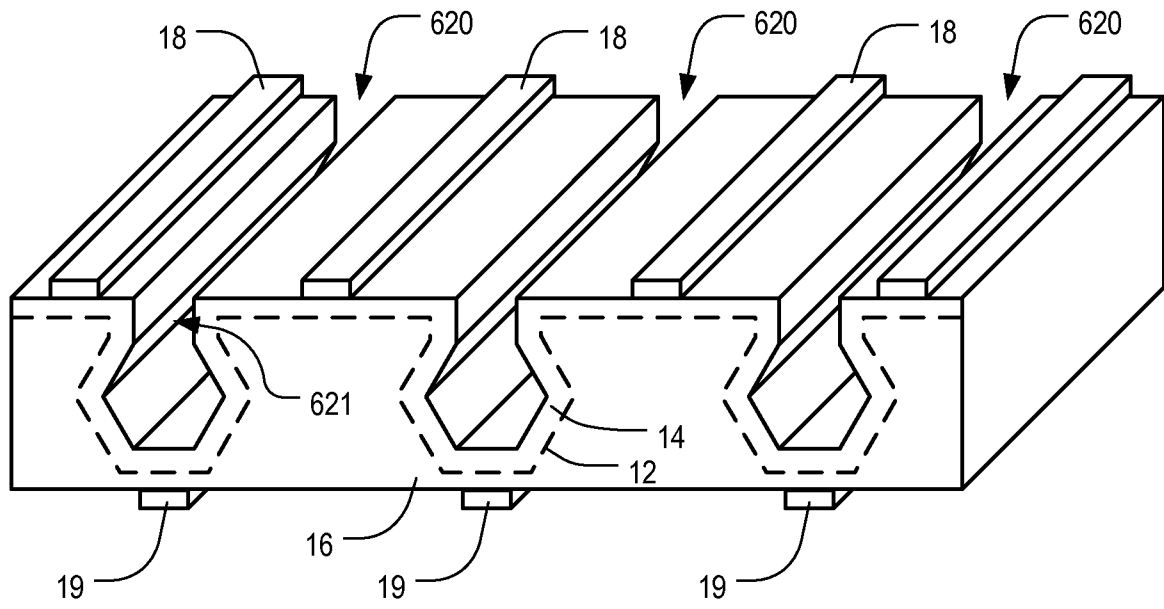

FIG. 18