



(12) **EUROPEAN PATENT APPLICATION**

(43) Date of publication:
19.04.2017 Bulletin 2017/16

(51) Int Cl.:
B05B 15/12 (2006.01) F26B 21/02 (2006.01)

(21) Application number: **16382463.4**

(22) Date of filing: **11.10.2016**

(84) Designated Contracting States:
AL AT BE BG CH CY CZ DE DK EE ES FI FR GB GR HR HU IE IS IT LI LT LU LV MC MK MT NL NO PL PT RO RS SE SI SK SM TR
 Designated Extension States:
BA ME
 Designated Validation States:
MA MD

(71) Applicant: **Roisber Servicios, S.L.**
15010 A Coruña (ES)

(72) Inventor: **RODRÍGUEZ LÓPEZ, Francisco de Asís**
15010 A Coruña (ES)

(74) Representative: **Pons Glorieta Ruben Dario 4**
28010 Madrid (ES)

(30) Priority: **16.10.2015 ES 201531497**

(54) **CONVERTIBLE PAINT BOOTH**

(57) Convertible work booth with vertical columns and a ceiling, which comprises at least two lateral air channels connected to at least one central air channel and one outer air inlet (5). The booth comprises plates equipped with openings placed in line with the central ceiling channel, in order to allow for the passage of air from the channel towards the enclosure. It also comprises a plurality of shutter sheets in line with the openings,

to control the air flow that passes through said openings. It also comprises at least one plenum (8) located beneath the plates equipped with openings and two vertical ducts (12), connected to a lateral air channel, which are equipped with an inner air inlet in the lowest area of the enclosure. The vertical ducts (12) may be laterally movable, and the plenum (8) may be vertically movable.

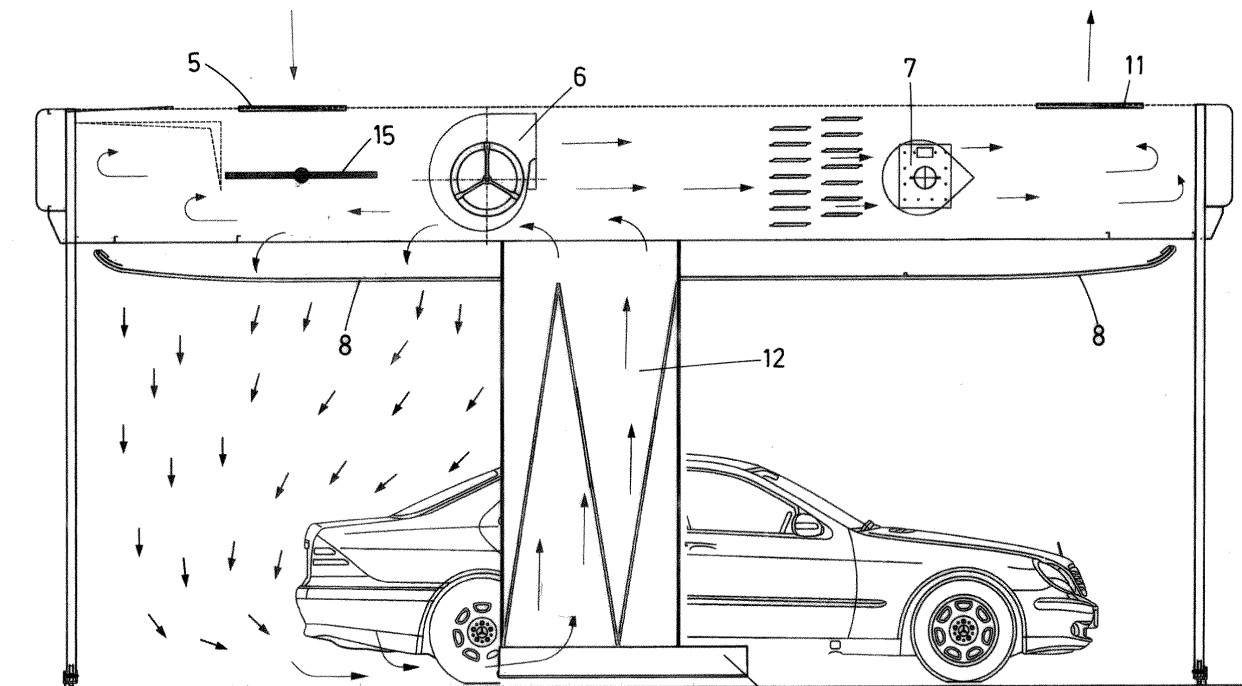

FIG.5

Description**OBJECT OF THE INVENTION**

[0001] The present invention is framed within the technical field of industrial work facilities and, more specifically, those used in the automobile sector.

[0002] A convertible work facility for automobiles is disclosed which acts as a facility for total vehicle bodywork repairs and may also act as an oven to favour drying following certain operations.

BACKGROUND OF THE INVENTION

[0003] In the prior art, workstations are known wherein operators perform repair operations on vehicles.

[0004] The most significant problem associated with this type of workstations is the high amount of resources required, i.e. the associated high energy consumption.

[0005] In most cases, the repairs to be made to a vehicle do not entail repairing the entire vehicle. However, it is necessary to keep the entire interior of the workstation under suitable conditions for the presence of operators. It is necessary that the latter work in a safe environment for their health.

[0006] Moreover, in many cases, vehicle repair operations are not considered to be completed until the vehicle is heated or dried. For example, in many cases, once the vehicle has been painted, it is convenient to subject it to heating and drying in order to guarantee a correct result. In the ovens known in the prior art, the energy consumption is very high because the interior is heated in an anarchical manner. Therefore, it is necessary to raise the temperature of the entire interior of the oven in order to achieve good results.

DESCRIPTION OF THE INVENTION

[0007] The convertible work facility for automobiles makes it possible to perform vehicle bodywork repair operations and, moreover, acts as an oven in those cases wherein drying operations are necessary.

[0008] The convertible work booth comprises an enclosure designed for the reception of a vehicle (or, at least, a part of a vehicle). The enclosure is defined by at least vertical columns and a ceiling, and may comprise lateral walls, which extend between the vertical columns and the ceiling, and are movable (i.e. they may be completely opened). The booth ceiling comprises air channels for the recirculation of the air inside the booth enclosure and to take in air from the exterior and send it to said enclosure.

[0009] The air from the ceiling channels is sent to at least one plenum, where it is distributed and from where it descends, thereby generating a laminar air flow that homogeneously descends through the interior of the booth. This generates a healthy work environment in the booth enclosure and all the potential dust generated dur-

ing the vehicle repair operations is swept along. The residues are swept towards the floor, where they are extracted by the vertical ducts and once again directed towards the ceiling. A plurality of filters are placed in the vertical ducts and the ceiling channels, in order to allow for the purification of the circulating air. Moreover, this air is released into the environment and is not recirculated.

[0010] A significant advantage of the present invention is that it makes it possible to organise the ventilation by sectors. Thus, if only the front part or the rear part of a vehicle is to be repaired, it is not necessary to ventilate the entire booth. In these cases, the ventilation may be accelerated in only one of the areas, whilst the other area is only slightly ventilated in order to eliminate the dust particles that may originate in the work area and eliminate the gases.

[0011] In order to select different air flow rates by areas inside the enclosure, there are plates equipped with openings, placed in line with the ceiling channels, and shutter sheets that move to control the opening or closing of the openings. Preferably, these nozzles are formed by superimposed shutters, such that, when the shutter openings are placed in line, passage of air is allowed and, when they slide over one another, passage of air is blocked. Moreover, depending upon the relative position between them, the air flow allowed to pass may be regulated.

[0012] When the vehicle repair operations are completed, the convertible station may act as an oven, in order to raise the drying temperature. To this end, a flap located on the ceiling, facing the outer air inlet, is opened. In this way, the previously heated air is recirculated.

[0013] The drying operation in the oven mode may also be organised by sectors. I.e. we may increase the temperature in the front area or the rear area of the booth depending on the specific needs. The shutters described above are also used for this purpose. This entails a big advantage as compared to traditional ovens, which are heated in an anarchical manner, thereby wasting a lot of energy.

[0014] In order to increase the drying efficacy, the air may be directed through the central ducts (i.e. allowing the passage of air only through the central shutters). The air descends at a greater velocity, thereby generating a hot air jet throughout the booth and along the vehicle; consequently, the exterior thereof is heated without this affecting the rest of the vehicle (interior, underfloor, engine, etc.).

[0015] This air jet may be targeted on the front or the rear part, which prevents the dispersal of the hot air throughout the booth enclosure (as in the case of traditional ovens), and targeted on the surface that is to be heated.

[0016] The interior of the booth is also equipped with vertical ducts, with an inner air inlet located on the lower part. The vertical ducts contain filters designed to retain the particles suspended in the air, which are absorbed

from the interior of the booth. In a preferred embodiment, said filters are placed in a zig-zag arrangement and make it possible to retain the suspended paint.

[0017] Preferably, in line with said inner air inlet, there is a raised plinth that forms a suction hood joined to the respective vertical duct. This makes it possible to suck in the air from the enclosure very close to the vehicle and create a trough on the lowest part thereof. Thus, all the air supplied by the plenum is forced to descend in a homogeneous manner around the vehicle. The operator may climb the plinth in order to facilitate operations such as painting of the upper part of the vehicle, or rotate it in order to gain access to the low part of the vehicle.

[0018] The proposed booth does not require civil works, because it is not necessary to have a pit or a grating on the floor in order to allow for the exit of air and because all the equipment in the facility (such as, for example, the blower, the motors used to move the booth when it is movable, the electrical cabinet, etc.) are located on the ceiling of the structure.

DESCRIPTION OF THE DRAWINGS

[0019] In order to supplement the description being made, and to contribute to a better understanding of the characteristics of the invention, according to a preferred embodiment thereof, a set of drawings is attached to said description as an integral part thereof, where the following is represented for illustrative, non-limiting purposes:

Figure 1 shows an upper perspective view of the convertible work booth without the lateral walls.

Figure 2 shows a view of the convertible work booth ceiling.

Figure 3 shows a profile view of the convertible work booth and represents the direction of the air when it exits only through the central area, moving around the vehicle towards the inner air inlet of the vertical ducts.

Figure 4a shows a view of the convertible work booth ceiling, where the plates equipped with openings may be observed.

Figure 4b shows a view similar to that of Figure 4a with some of the openings open and others completely covered.

Figure 5 shows an upper view of the convertible work booth and represents the direction of the air when the ventilation is only activated in the rear section of the enclosure.

Figure 6 shows a view of a plate equipped with openings, wherein some are completely closed by a shutter sheet and others are only partially open.

Figure 7 shows a profile view of the convertible work booth with the plenum shifted downward.

Figure 8 shows a lower perspective view of the convertible work booth with the lateral walls.

Figure 9 shows a top view of the convertible work booth and a plurality of vehicles located at each of

the sides, through which they may enter the enclosure.

PREFERRED EMBODIMENT OF THE INVENTION

[0020] With the aid of the aforementioned Figures 1-9, below it is described a preferred embodiment of the present invention.

[0021] The proposed convertible work booth may be observed, for example, in Figure 1. Inside the booth, repair operations may be performed on a vehicle, a part of a vehicle or other types of parts that need to be painted, welded, sanded, etc. Moreover, the work booth itself is converted into an oven in those cases wherein it is necessary to heat the vehicle, a part of the vehicle or the corresponding part following the repair operations.

[0022] It is a work booth of the type that comprises an enclosure (4) designed to receive an automobile whereon a plurality of repair operations are to be performed. As may be observed in Figure 1, said enclosure (4) is assembled between vertical columns (2) and a ceiling (3) supported on the vertical columns (2).

[0023] The ceiling (3) has been represented in detail in Figure 2. As may be observed, it comprises at least two lateral air channels (18) connected to at least one central air channel (19), one outer air inlet (5), one air with gases outlet (11), one blower (6) and one heating element (7).

[0024] The outer air inlet (5) makes it possible to obtain clean, pure air from outside the booth. The air with gases outlet (11) makes it possible to purify the air that circulates throughout the booth when it is highly mixed with the gases that may have been produced during the repair operations inside the enclosure (4). Prior to releasing the air with gases into the environment, they are forced to pass through several filters in order to prevent damage to the atmosphere.

[0025] The blower (6) allows for the movement of air through the ceiling channels (3) and the heating element (7) makes it possible to condition the air jet that circulates through said channels.

[0026] The most important characteristic of the present invention is that both the delivery of outer air to the enclosure (4) and, in those cases when it acts as an oven, the delivery of hot air to the enclosure (4) are performed in a completely controlled manner. This makes it possible to send the air (whether outer air or hot air) to those areas where it is really necessary, thereby allowing for great energy savings.

[0027] To this end, the booth comprises plates equipped with a plurality of openings (9) arranged in line with the central air channel (19) on the ceiling (3), through which the air that circulates through said central air channel (19) exits towards the enclosure (4). In line with said openings (9), there is a plurality of shutter sheets (10) that may be moved, in order to control the air flow that goes through said openings (9), by covering or opening them in whole or in part.

[0028] Preferably, the shutter sheets (10) comprise secondary openings with the same configuration as the openings (9) designed for the passage of air, such that, when the shutter sheets (10) equipped with the secondary openings are placed over the openings (9), the latter are completely open. As the shutter sheet (10) slides, the effective size of the openings (9) is reduced and the air flow that goes through them decreases. Finally, the openings (9) close when they are completely covered by the shutter sheets (10).

[0029] Moreover, the convertible work booth comprises at least one plenum (8) placed below the plates equipped with openings (9), which receives the air that exits through the openings (9) towards the enclosure (4), and filters it prior to releasing it in the enclosure (4). Figure 3 represents a profile view of the booth, wherein the plates equipped with openings (9) and the plenum (8) in working position may be observed.

[0030] The booth also comprises at least two vertical ducts (12), each connected to a lateral air channel (18) through one of the ends, and with an open end that comprises an inner air inlet (13). The inner air inlet (13) is located on the lowest area of the enclosure (4), in order to create a trough in the lower area of the vehicle and thus ensure that the air that exits through the ceiling (3) (through the plenum (8)) vertically travels throughout the entire enclosure (4). The vertical ducts (12) once again drive the air from the interior of the enclosure (4) towards the ceiling channels (3) in order to recirculate it.

[0031] Preferably, the interior of the vertical ducts (12) contain a plurality of filters, placed in a zig-zag arrangement, designed to retain the particles that may have been produced during the painting, welding, sanding, etc. operations. Said particles are swept by the air jet that exits the plenum (8), vertically, towards the lower area of the enclosure (4), in order to enter the vertical ducts (12) through the inner air inlet (13).

[0032] In one embodiment, the plenum (8) is attached to the ceiling (3) and is capable of vertical movement. Preferably, the plenum (8) is supported by cables that may be manipulated by means of a manual or motorised reel, which keep the plenum (8) completely airtight, snug fit against the ceiling (3). The plenum (8) may be lowered to the desired height in order to change the filters.

[0033] In a preferred embodiment of the invention, the booth comprises two plena (8) which divide the enclosure (4) into a front section and a rear section. This entails a great advantage, because it makes it possible to release air in the enclosure (4) only in the area where it is necessary. In order to allow for this air release control by sections, the shutter sheets (10) move independently from one another, and are preferably operated by means of actuators (20), which may be manual or automatic.

[0034] For example, in the event that it is necessary to repair the rear part of a vehicle, the latter is placed in the booth enclosure (4) and only those openings (9) that are placed in line with the plenum (8) on the front section are left open. In this way, the air that circulates through the

central channel (19) on the ceiling (3) is only released through said openings (9) and neither air nor energy are wasted when ventilating the front section, whereon no work is being performed.

[0035] Figure 4a represents the plates equipped with openings (9). Figure 4b represents an operating example wherein only some of the openings (9) are open (represented in black, as opposed to the rest of the openings (9), which are open). In Figure 5, we may observe the effect of allowing passage of air only through openings (9) in the rear section. Figure 6 represents some openings (9) that are totally covered by the shutter sheets (10) and others that are only partially covered.

[0036] Moreover, each of the sections comprises a plurality of shutter sheets (10) designed to guide the air that exits from the ceiling (3) towards the enclosure (4). By opening or closing the appropriate openings (9), air may be released onto the sides of the enclosure (4) or onto the central area. For example, Figure 3 shows the air exiting only through the central area.

[0037] This application is especially important in those cases wherein the booth acts as an oven. In said cases, a defined hot air jet (air that has been heated by the heating element (7) in the ceiling channels (3) or has been previously heated and is being recirculated) is blown on the automobile.

[0038] In the embodiment represented in the figures, the booth comprises six shutter sheets (10), three of them placed in the front section and three of them in the rear section. The shutter sheets (10) in each section are in line, respectively, with two lateral plates and a central plate, in order to allow for the passage of air through the central area or one of the lateral areas (in the event that repairs are only being performed on one side of the vehicle). As may be observed in Figures 4a and 4b, the actuators (20) that control the movement of the shutter sheets (10) are located at an intermediate area between the front section and the rear section, and there are three of them, each controlling one shutter sheet (10) in the front section and its corresponding shutter sheet in the rear section.

[0039] Another advantage of the present invention is that the inner air inlets (13) are placed on the ends of the vertical ducts (12), which are located on the lowest area of the enclosure (4). Preferably, said inner air inlets (13) are close to the vehicle underfloor. This ensures that the air flow travels vertically throughout the entire exterior of the vehicle.

[0040] In an embodiment such as the one shown in Figure 6, the booth further comprises a collapsible plinth (14) joined to the open end of the vertical ducts (12), in line with the inner air inlet (13). This plinth (14) forms a suction hood that reinforces the air suction effect from the enclosure (4) towards the corresponding vertical duct (12). Moreover, the operator may climb the plinth (14) in order to facilitate those operations performed on the upper part of the vehicle. In addition to being collapsible, it may be rotated in order to raise it, such that the operator

may make repairs on the lower part of the vehicle. Said Figure 6 represents a plinth (14) in its habitual position and one that has been rotated to allow the operator to work on the lower part of the vehicle.

[0041] In order to act as an oven, the convertible work booth comprises at least one movable flap (15), placed in line with the outer air inlet (5), as represented in Figure 5. Said movable flap (15) moves between a first position, wherein it allows for the passage of air through said outer air inlet (5), and a second position, wherein it blocks the passage of air through the outer air inlet (5). Figure 5 represents the first position. When it moves to the second position, the working air is only recirculated air that is heated to a certain extent with the heating element (7), depending on the specific needs. This embodiment does not exclude the presence of an outer air inlet designed to purify the air that is being recirculated, whilst, at the same time, a part of the air with gases or the air that has already been recirculated for a given period of time is released to the exterior.

[0042] Another noteworthy characteristic of the convertible work booth is that it makes it possible to introduce the vehicle into the enclosure (4) through any of the sides, the front area or the rear area. To this end, the booth comprises lateral walls placed between the vertical columns (2) designed to close the enclosure (4), and said lateral walls (17) are movable. In Figure 8, the booth with the lateral walls (17) may be observed.

[0043] Moreover, the booth may be installed in a fixed position or may be capable of moving laterally. In the event that the booth is installed in a fixed position, an operator must take the vehicle into the enclosure (4) and subsequently remove it. In the event that the booth is movable, as shown in Figure 9, it may comprise wheels (16) on the vertical columns (2) which allow for vertical movement, such that it may move along a row of vehicles until all of them are repaired. In said Figure 9, we may observe that the vehicle may be introduced into the enclosure (4) through any of the lateral walls (17).

Claims

1. Convertible work booth of the type that comprises an enclosure (4) defined between:

- vertical columns (2), and
- a ceiling (3), supported on the vertical columns (2), which comprises at least:

- two lateral air channels (18) connected to at least one central air channel (19),
- one outer air inlet (5),
- one air with gases outlet (11),
- one blower (6),
- one heating element (7),

and is **characterised in that** it comprises:

- plates equipped with a plurality of openings (9) placed in line with the central air channel (19) of the ceiling (3), through which the air that circulates through said central air channel (19) exits towards the enclosure (4),
- a plurality of shutter sheets (10), placed in line with the openings (9), which are capable of moving to control the air flow that passes through said openings (9), by covering or opening them in whole or in part,
- at least one plenum (8) placed beneath the plates equipped with openings (9), which receives the air that exits from the openings (9) towards the enclosure (4), filtering it prior to releasing it in the enclosure (4),
- two vertical ducts (12), each connected through one of its ends to a lateral air channel (18), and with an open end that comprises an inner air inlet (13) and is located on the lowest area of the enclosure (4), configured in such a way so as to guide the air in the interior of the enclosure (4) towards the ceiling (3) channels.

2. Convertible work booth according to claim 1, wherein the shutter sheets (10) move independently from one another, operated by actuators (20).

3. Convertible work booth according to claim 1, wherein the plenum (8) is attached to the ceiling (3) by means of cables that allow for the vertical movement thereof.

4. Convertible work booth according to claim 1, further comprising a collapsible plinth (14) joined to the open end of the vertical ducts (12), in line with the inner air inlet (13).

5. Convertible work booth according to claim 1, comprising at least one movable flap (15), placed in line with the outer air inlet (5), which moves between a first position, wherein it allows for the passage of air through said outer air inlet (5), and a second position, wherein it blocks the passage of air through the outer air inlet (5).

6. Convertible work booth according to claim 1, further comprising lateral walls (17) placed between the vertical columns (2), designed to close the enclosure (4), said lateral walls (17) being movable.

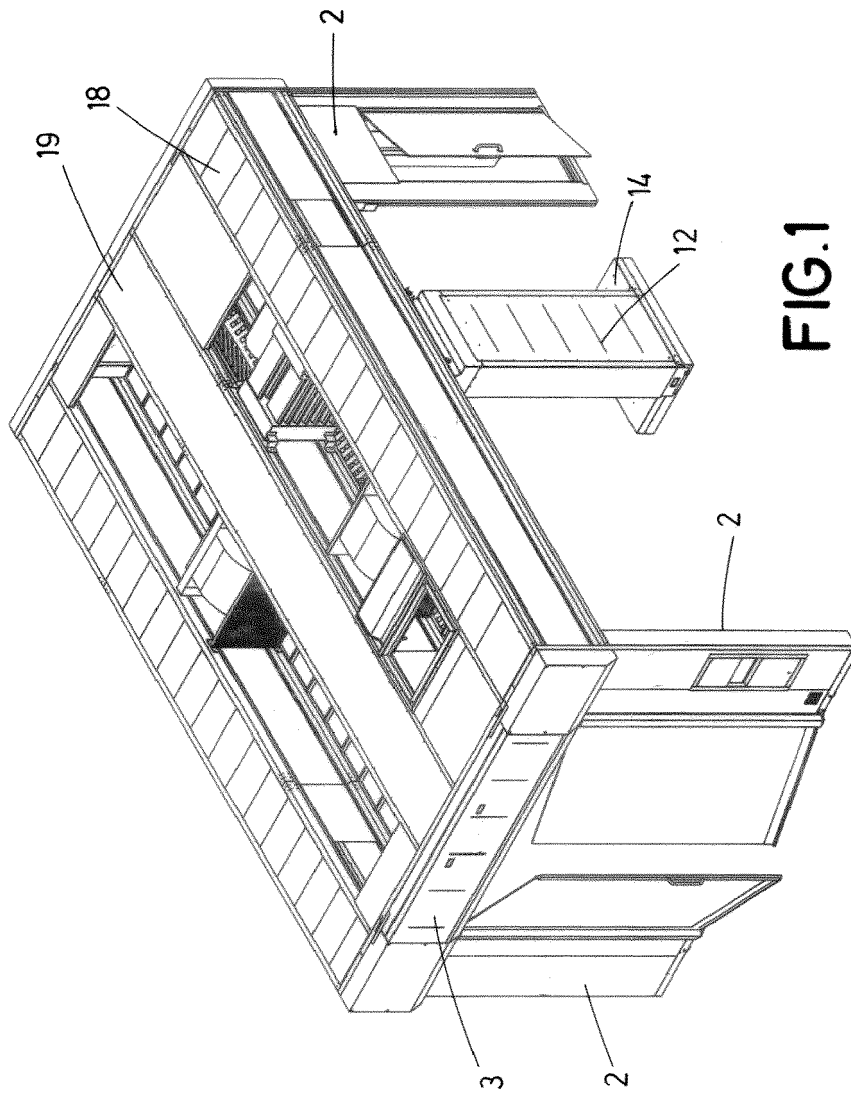

FIG.1

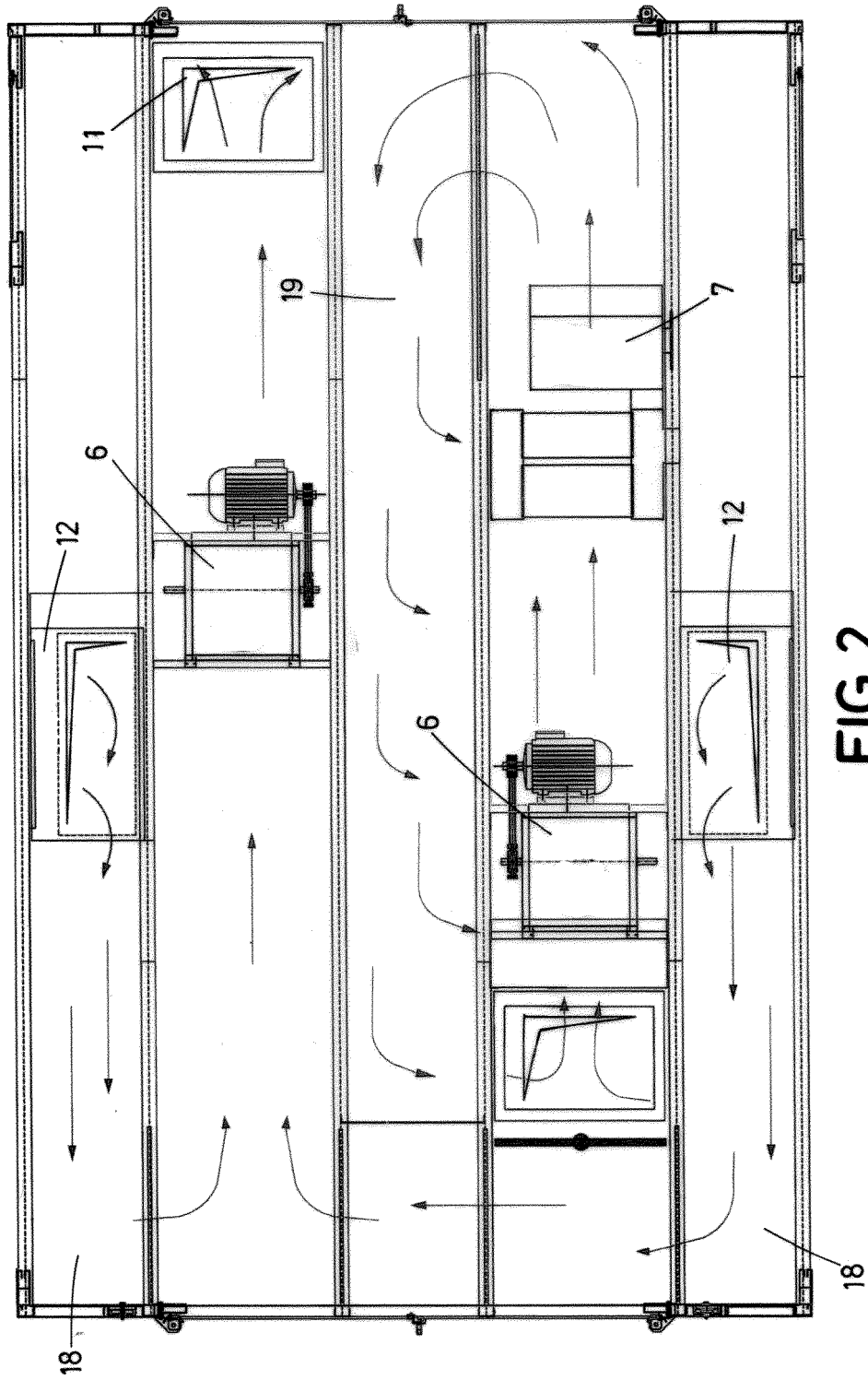
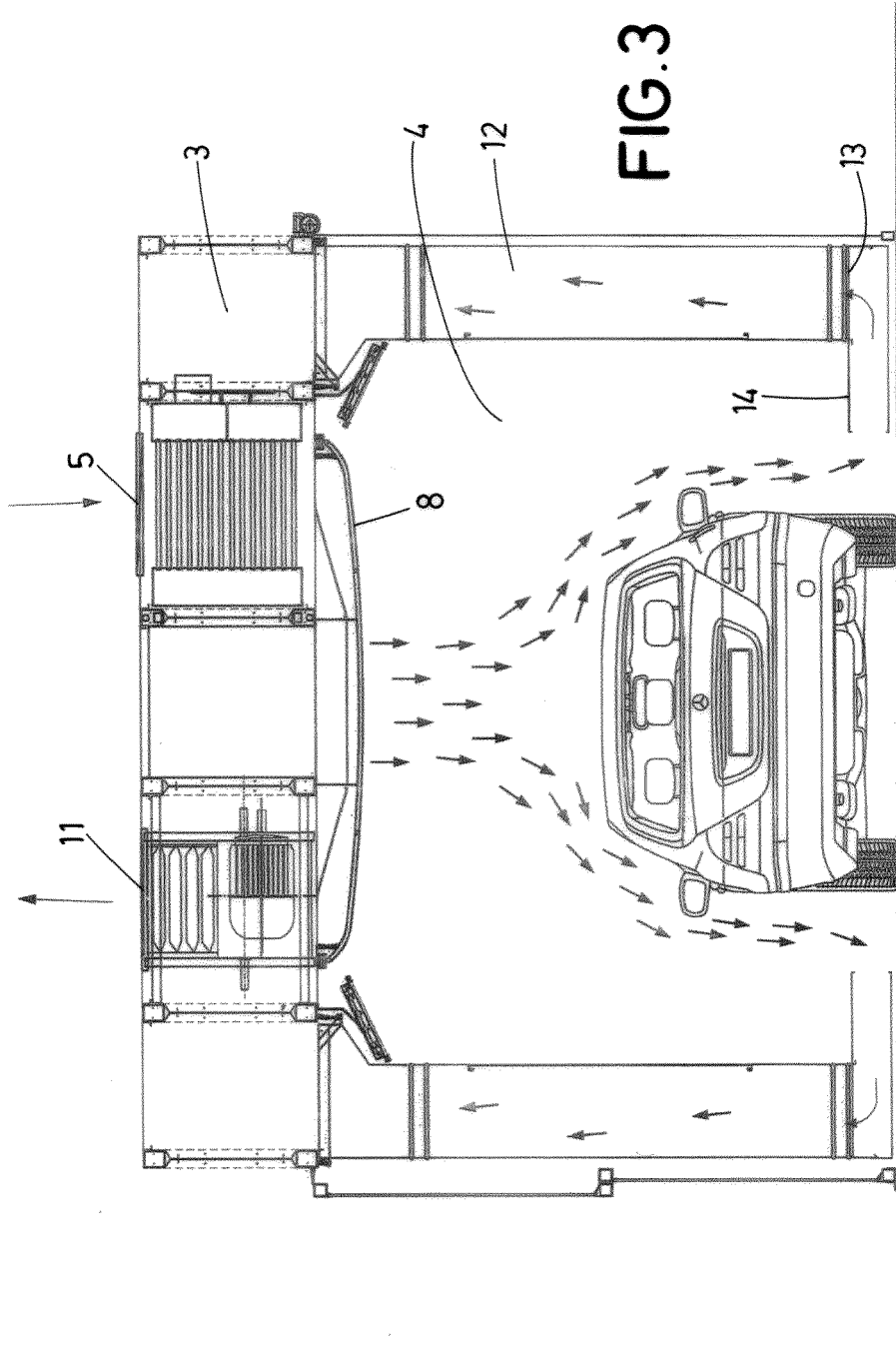

FIG.2



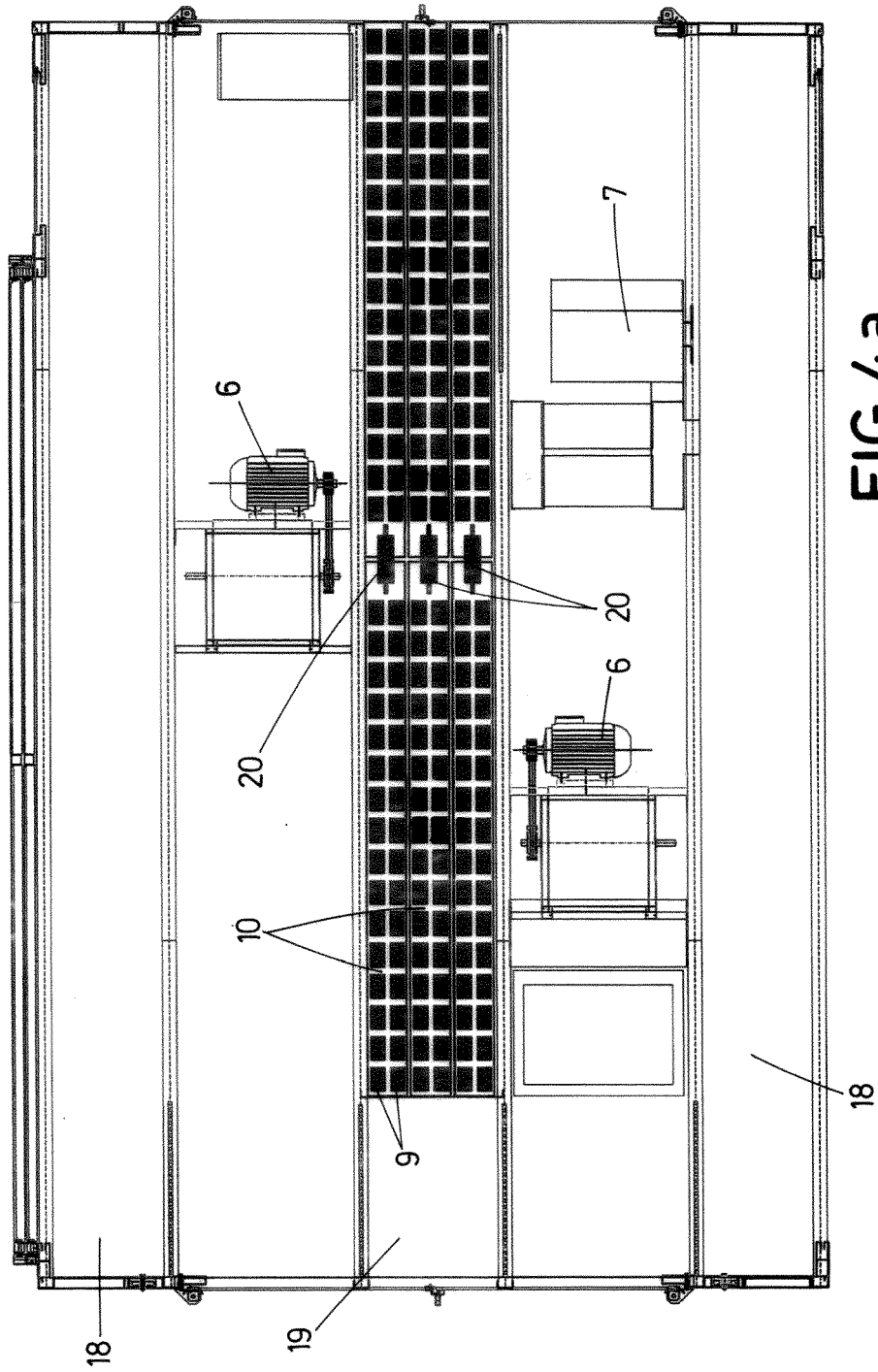

FIG.4a

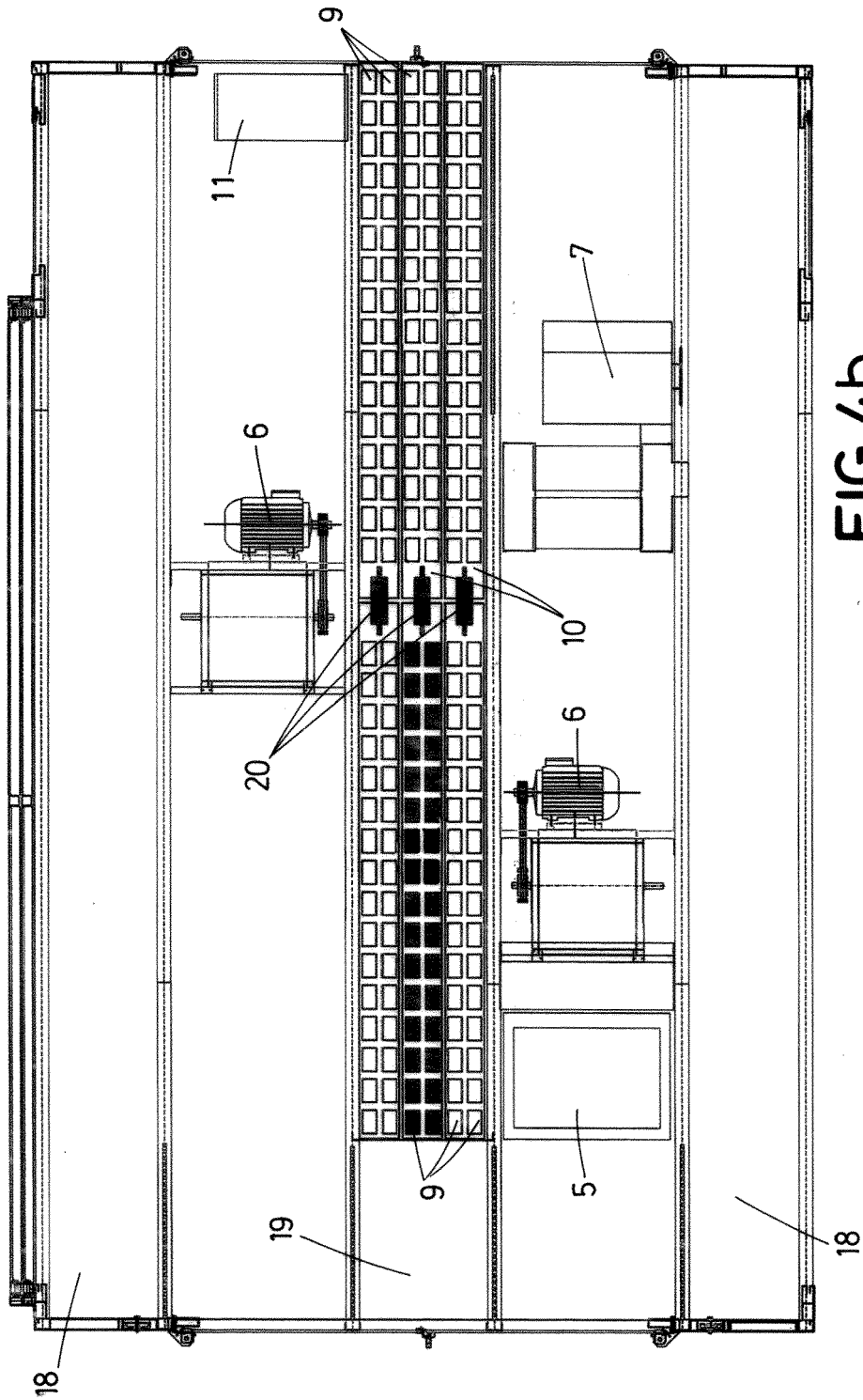

FIG. 4b

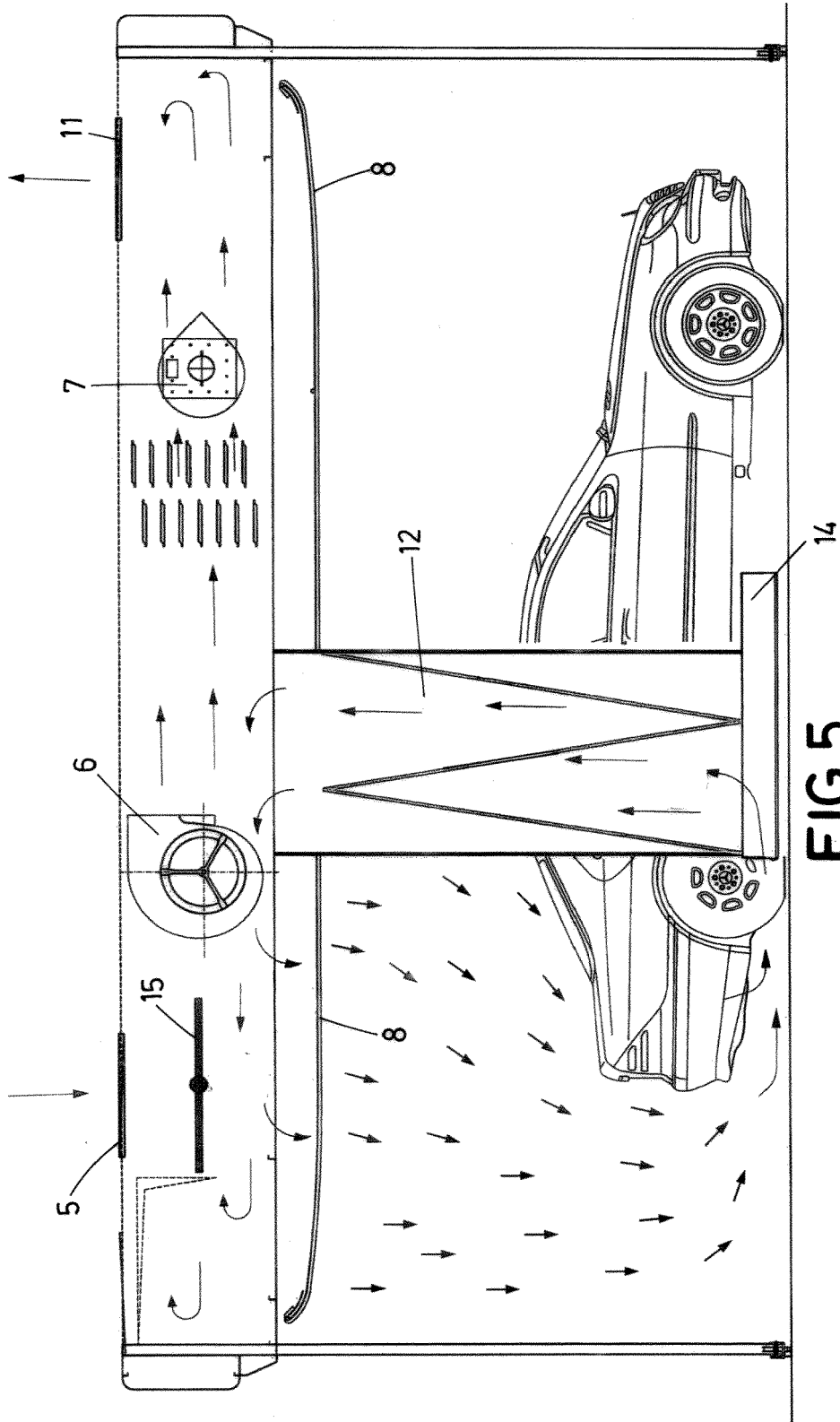

FIG.5

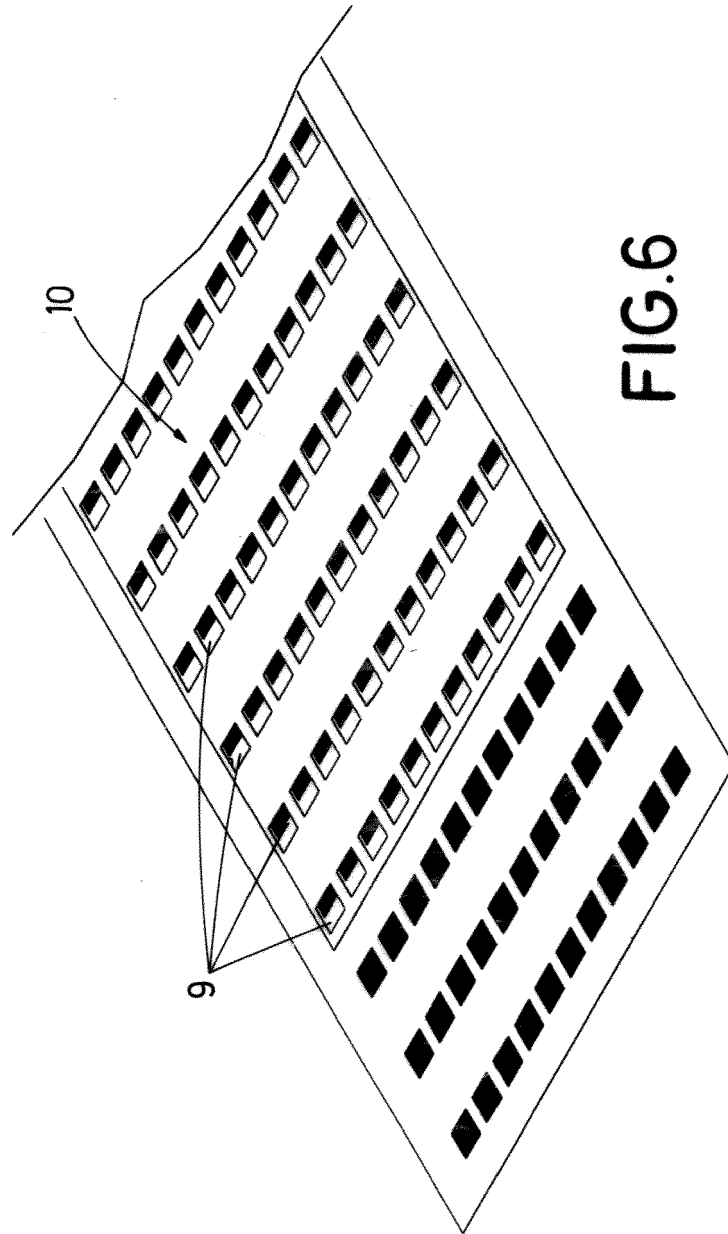
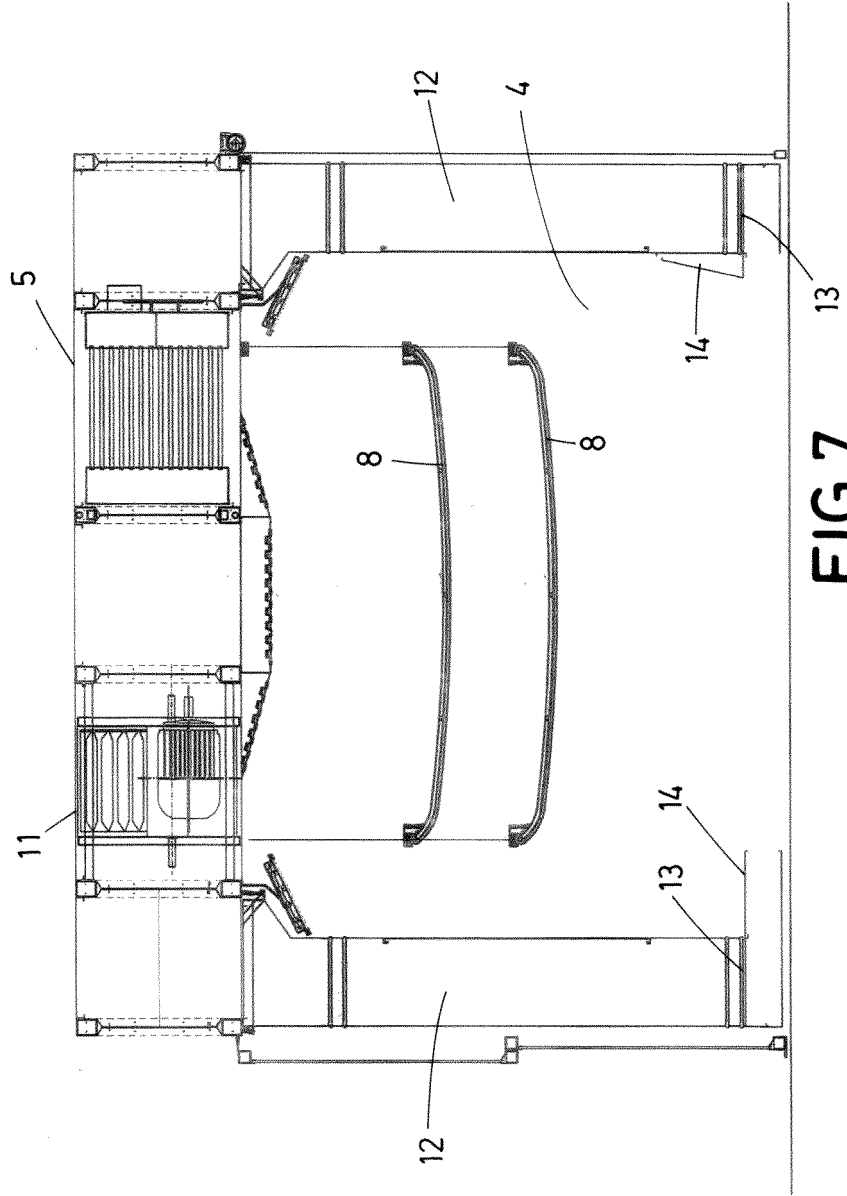

FIG. 6



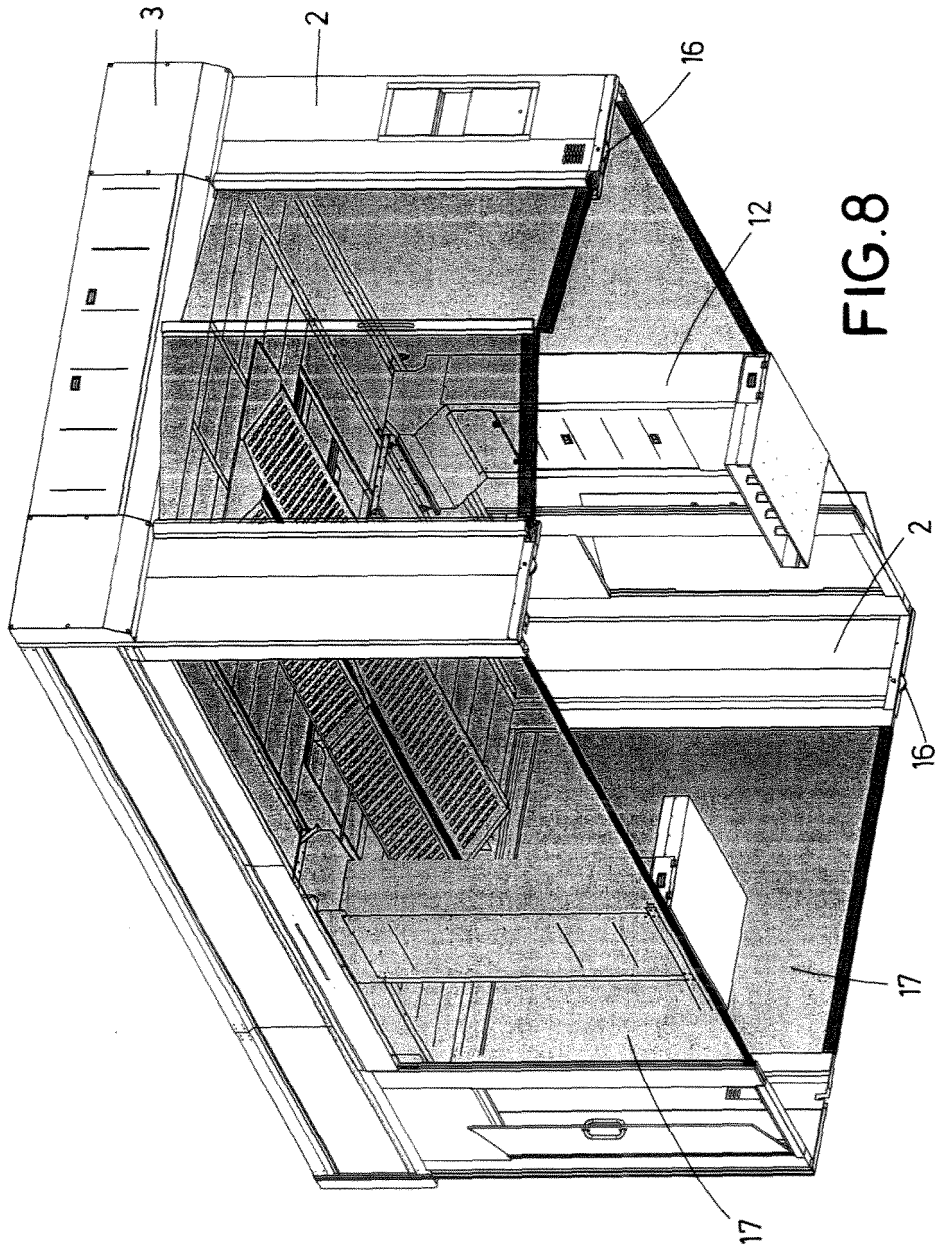
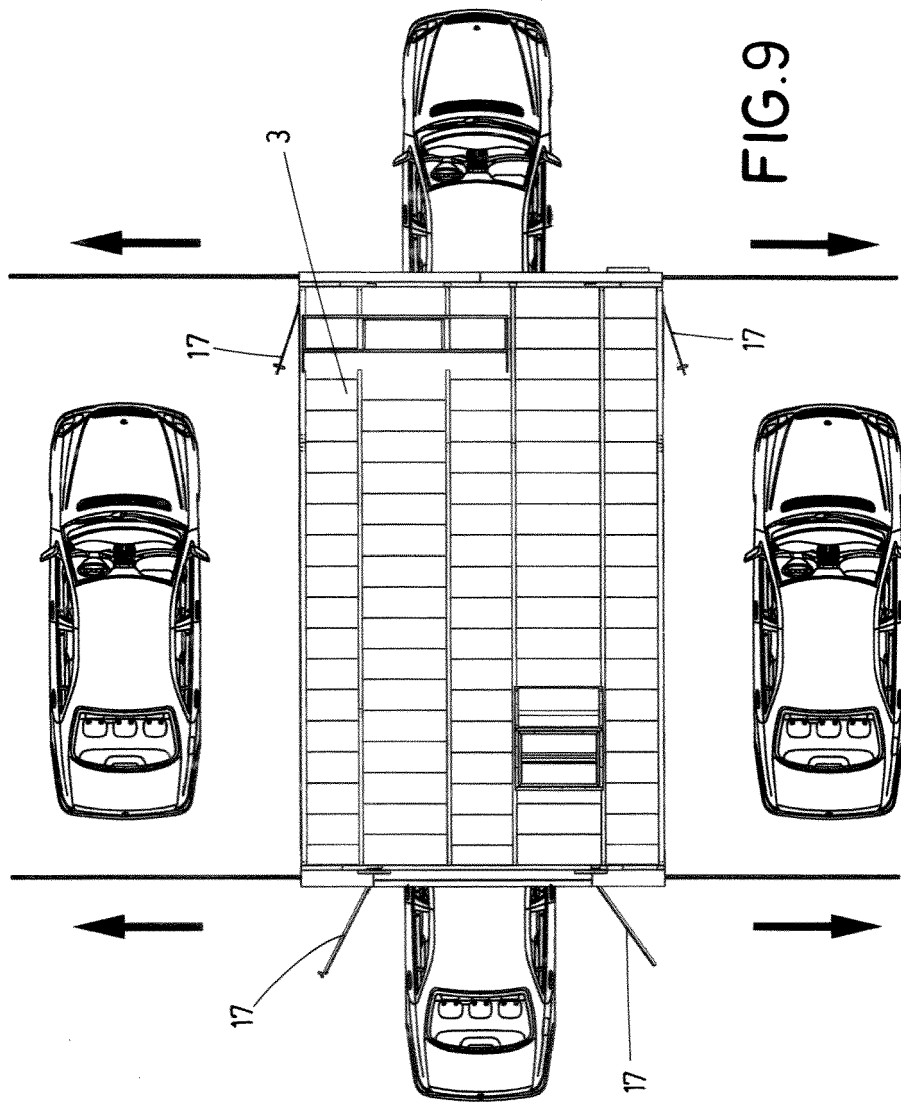

FIG.8





EUROPEAN SEARCH REPORT

Application Number
EP 16 38 2463

5

10

15

20

25

30

35

40

45

50

55

DOCUMENTS CONSIDERED TO BE RELEVANT			
Category	Citation of document with indication, where appropriate, of relevant passages	Relevant to claim	CLASSIFICATION OF THE APPLICATION (IPC)
X	EP 0 849 001 A1 (WAELTI ROBERT SEN [CH]) 24 June 1998 (1998-06-24) * column 11, line 46 - column 12, line 26; claims 4,6; figures 2,3 *	1,2,5	INV. B05B15/12 F26B21/02
Y	US 2013/337733 A1 (SPRAYBOOTH TECHNOLOGY LTD [GB]; WILLIAMS MICHAEL [GB]) 19 December 2013 (2013-12-19) * paragraphs [0002], [0033], [0034]; claims 3,5,7; figures 5-8 *	1,2,4-6	
A	----- US 4 771 728 A (BERGMAN CHARLES H [US] ET AL) 20 September 1988 (1988-09-20) * claims 5, 9; figure 1 *	3	
Y	WO 2007/138558 A2 (USI ITALIA S R L [IT]; GREGGIO MASSIMO [IT]) 6 December 2007 (2007-12-06) * claims 4,6,9,10,13 *	1,2,4-6	
Y	US 5 855 509 A (WHITE WILLIAM H [US] ET AL) 5 January 1999 (1999-01-05) * claims 1, 2,3,5,7,10,14,16; figures 3,8a *	1-3,5	TECHNICAL FIELDS SEARCHED (IPC) B05B F26B
The present search report has been drawn up for all claims			
Place of search Munich		Date of completion of the search 7 March 2017	Examiner Marin, Charles
CATEGORY OF CITED DOCUMENTS X : particularly relevant if taken alone Y : particularly relevant if combined with another document of the same category A : technological background O : non-written disclosure P : intermediate document T : theory or principle underlying the invention E : earlier patent document, but published on, or after the filing date D : document cited in the application L : document cited for other reasons & : member of the same patent family, corresponding document			

EPO FORM 1503 03/02 (P04C01)

ANNEX TO THE EUROPEAN SEARCH REPORT
ON EUROPEAN PATENT APPLICATION NO.

EP 16 38 2463

5

This annex lists the patent family members relating to the patent documents cited in the above-mentioned European search report. The members are as contained in the European Patent Office EDP file on The European Patent Office is in no way liable for these particulars which are merely given for the purpose of information.

07-03-2017

10

15

20

25

30

35

40

45

50

55

Patent document cited in search report	Publication date	Patent family member(s)	Publication date
EP 0849001 A1	24-06-1998	AT 227609 T	15-11-2002
		AU 5186398 A	17-07-1998
		DE 59708735 D1	19-12-2002
		EP 0849001 A1	24-06-1998
		EP 0944437 A1	29-09-1999
		HU 0001635 A2	28-09-2000
		NO 992978 A	12-08-1999
		PL 334195 A1	14-02-2000
		SK 80999 A3	08-11-1999
		US 6264547 B1	24-07-2001
		WO 9828088 A2	02-07-1998
US 2013337733 A1	19-12-2013	AU 2011346909 A1	04-07-2013
		CN 103313799 A	18-09-2013
		EP 2654971 A1	30-10-2013
		GB 2486705 A	27-06-2012
		US 2013337733 A1	19-12-2013
		WO 2012085535 A1	28-06-2012
WO 2007138558 A2	06-12-2007	NONE	
US 4771728 A	20-09-1988	CA 1298078 C	31-03-1992
		JP S63126575 A	30-05-1988
		US 4771728 A	20-09-1988
US 5855509 A	05-01-1999	NONE	