

H. L. JOHNSON.

TELEPHONE SELECTIVE SIGNALING RINGER.

APPLICATION FILED MAR. 3, 1908. RENEWED SEPT. 19, 1910.

1,001,959.

Patented Aug. 29, 1911.

Fig. 2.

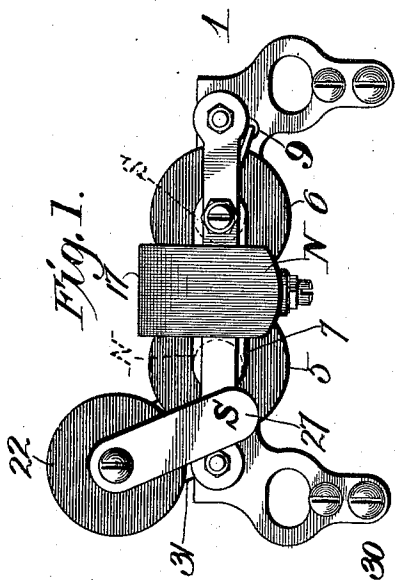
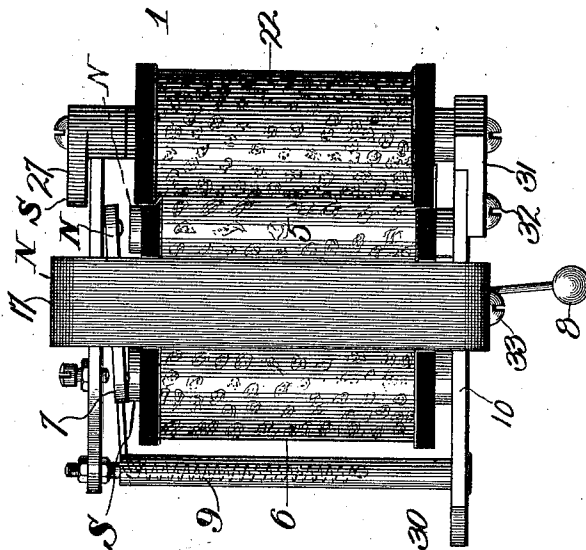

Witnesses  
Frank D. Gore  
H. C. Rodgers

Inventor  
H. L. Johnson.  
By *George F. Thorpe* Atty.

# UNITED STATES PATENT OFFICE.

HARRY L. JOHNSON, OF TOPEKA, KANSAS, ASSIGNOR OF SIX-TENTHS TO CLAY HAMILTON, OF TOPEKA, KANSAS.

TELEPHONE SELECTIVE-SIGNALING RINGER.

1,001,959.

Specification of Letters Patent. Patented Aug. 29, 1911.

Application filed March 3, 1908, Serial No. 419,049. Renewed September 19, 1910. Serial No. 582,782.

To all whom it may concern:

Be it known that I, HARRY L. JOHNSON, a citizen of the United States, residing at Topeka, in the county of Shawnee and State of Kansas, have invented certain new and useful Improvements in Telephone Selective-Signaling Ringers, of which the following is a specification.

This invention relates to selective party line telephone systems and more especially to selective signaling mechanism therefor, my object being to produce a mechanism of this character whereby any one of four parties on a metallic circuit line, may be signaled, selectively as desired, by the simultaneous sending of an alternating current over either of the line wires through the ringers to the ground and a direct current of certain polarity over the companion line wire, or by simultaneously sending a direct current of certain polarity and an alternating current over the same wire.

Before proceeding with a detailed description it is desired to call attention to the fact that the alternating current is employed to operate the bell clapper at each station while the direct current in one instance, is used to silence the ringer and in the other to cooperate with the alternating current in effecting the operation of the ringer.

With the object named in view, the invention consists in certain novel and peculiar features of construction and organization as hereinafter described and claimed; and in order that it may be fully understood reference is to be had to the accompanying drawing, in which—

Figure 1, is a top plan view of a ringer embodying my invention. Fig. 2, is a rear view of the ringer.

Briefly the invention consists in the equipment of an ordinary ringer with an additional electro-magnet to be excited independently of the ringer magnet by a direct current for the purpose of neutralizing or diverting the effect of the permanent magnet when it is to be silenced or cooperating with said magnet to strengthen its effect on the armature of the ringer and hence increase the volume of sound produced by the same, it being understood that the neutralization and diverting of the lines of force of the regular ringer magnet or the increased effect which it has through cooperation with the additional electromagnet depends wholly on the

polarity of the direct current, that is to say on the direction in which the current flows.

Referring to the drawing in detail, 1 indicates a ringer consisting of a pair of coils 5 and 6, and an armature 7 equipped with a clapper 8, held by the usual spring 9, in the position shown.

17 indicates the usual permanent magnet and 33 a clamping screw extending through the lower arm of said magnet into the base 10 of the ringer to hold the magnet reliably in position.

22 is an electromagnet arranged at one side of the permanent magnet 17, and mounted on the base 10 of the ringer, and the said magnet is of such arrangement and resistance that it shall either cooperate with or neutralize the effect of the permanent magnet on the armature and the cores of the coils 5 and 6.

The electro-magnet 22 is provided at its lower end with an arm 31 to be clamped by a screw bolt 32 to the said base, and as said magnet is placed parallel with the permanent magnet, the former may be energized in such a way as to make the free end of its core of the same polarity as the free end of the permanent magnet. On the other hand the coil 22 may be energized in such a way as to make the free end of the core of opposite polarity to that of the free end of the permanent magnet, when the connection would be such that the lines of force would escape from one magnet to the other.

Assuming that the circuit is completed through the ringer by the usual means, not shown, it will be seen that an alternating current passing through the ringer coils 5 and 6, effects the operation of the armature 7, and results in the ringing of the bell (not shown), of the ringer, through the action of the clapper.

Supposing the free end of the permanent magnet 17 to be of north polarity, N, then the armature 7 will be of north polarity, N, from the induced lines of force of the permanent magnet. The cores of the coils 5 and 6 will be of south polarity, S, from the lines of force set up by the south polarity of the attached end of the permanent magnet 17. Assuming the first impulse or pulsation of the current in the coils 5 and 6 to be of such direction as to make the core of coil 5 of north polarity, as indicated by the dotted letter N, the armature will be repelled from

this pole, at the same instant the core of coil 6 will be of south polarity, as shown by the dotted letter S, and will attract the armature 7. Assuming that the next impulse of current is of such direction as to make the free end of the core of coil 5 of south polarity and the free end of the core of coil 6 of north polarity, the armature 7 is attracted to the south pole of the coil 5 and repelled at the north pole of coil 6. By these actions the alternating current will vibrate the armature 7 and ring the bell.

Supposing the free end of the permanent magnet 17 to be of north polarity, N, and that a direct current is passing through the electro-magnet 22 in such a direction as to make its free end of south polarity, it will be evident that a closed magnetic circuit will be formed, as the lines of force from the north polarity of the free end of the permanent magnet 17 will pass into the south polarity at the free end of the electro-magnet 22, thence to the north polarity of the same magnet, through the base of the ringer and into the attached pole of south polarity of the permanent magnet 17, that is to say, if the attached end of the permanent magnet 17 is of south polarity and the attached end of the electro-magnet 22 is of north polarity, then some of the lines of force of the north polarity of the electro-magnet 22 will enter into the south polarity or south pole of the attached end of the permanent magnet 17. It will be evident that if a stronger field of force is set up by the lines of force of the electro-magnet 22, that is set up by the permanent magnet, then the cores of coils 5 and 6 owing to their magnetic connection with the north polarity of electro-magnet 22, will be of north polarity instead of south polarity, ordinarily set up by the attached end of the permanent magnet for the reason that all of the lines of force of south polarity of the permanent magnet have fallen into line with those of north polarity of the electro-magnet 22. If the free end of the permanent magnet 17 is of north polarity, then the armature 7 is of north polarity. If the attached end of the electro-magnet 22 is of north polarity then the cores of the coils 5 and 6 will be of north polarity. With all of the poles alike there will therefore be no attraction and consequently no movement of the armature 7. Supposing that a current should be flowing in the coil 6, which would tend to make the core of that coil of south polarity, then all the energy created in that coil would be spent in overcoming and neutralizing the existing north polarity in that core by the magnetic effect established therein by the electro-magnet 22, and consequently there could be no movement of the armature 7. On the other hand if the ringer was to be operated then the direct current would be passed through the elec-

tromagnet 22 in such direction as to make its free end of the same polarity as the free end of magnet 17. In this additional lines of force created by the electro-magnet 22 will be added to the lines of force created by the magnet 17, creating a stronger field and inducing more magnetism into the armature 7 and the coils 5 and 6 and causing the ringer to operate with greater strength than when the permanent magnet is used alone.

In the construction shown the core of magnet 22 is provided with an extension 27, which projects toward and approximately over the adjacent end of the armature. It will be understood however, that the additional or auxiliary electro-magnet 22 if arranged in proper relation to the permanent magnet, will not need the extension 27, the relation between said magnets being such that with or without the extension 27, it is possible by sending a current of proper polarity through the electro-magnet to establish a magnetic circuit through the magnet 22, and the permanent magnet and thus neutralize the effect of the alternating current in the magnet composed of coils 5 and 6 and prevent the operation of the ringer.

I claim:—

1. The combination with an ordinary ringer for telephone systems, embodying an electro-magnet having a vibratory armature, and a permanent magnet with one end at the opposite side of the armature from the electro-magnet, of an additional electro-magnet arranged adjacent to the said permanent magnet and adapted when a direct current passes through it in one direction to cooperate with the permanent magnet in establishing a magnetic circuit whereby the effect of the first-named electro-magnet on the armature is neutralized and when a direct current of opposite polarity is passing through it to cooperate with the permanent magnet in strengthening the magnetic effect of the first-named electro-magnet on the armature to increase the volume of sound produced by the ringer.

2. A ringer for telephone systems, comprising a suitable base, an electro-magnet having its cores at one end secured to the base, a vibratory armature suitably supported contiguous to the opposite end of the magnet, a permanent magnet having one end at the opposite side of the vibratory armature from the electro-magnet, and its opposite end secured to the base at the opposite end of such electro-magnet, and a second electro-magnet adjacent to the permanent magnet and provided with a core-extension at one end contiguous to the armature at the opposite side of the same from the first-named electro-magnet and having its opposite end secured to said base.

3. A ringer for telephone systems, comprising a suitable base of conducting ma-

terial, an electro-magnet having its cores at  
one end secured to the base, a vibratory ar-  
mature suitably supported adjacent to the  
opposite ends of the cores of said magnet, a  
5 permanent magnet having one end attached  
to said base and its opposite end at the op-  
posite side of the armature from said electro-  
magnet, and a second electro-magnet in mag-  
netic relation at one end to the end of the  
10 permanent magnet which is attached to the  
said base and disposed at its opposite end  
adjacent to the said permanent magnet and  
adapted when a direct current passes through  
it in one direction to cooperate with the per-  
15 manent magnet in establishing a magnetic

circuit whereby the effect of the first-named  
electro-magnet on the armature is neutral-  
ized and when a direct current of opposite  
polarity is passing through it to cooperate  
with the permanent magnet in strengthening  
the magnetic effect of the first-named elec-  
tro-magnet on the armature to increase the  
volume of sound produced by the ringer.

In testimony whereof I affix my signature,  
in the presence of two witnesses.

HARRY L. JOHNSON.

Witnesses:

AUGUST P. BERG,  
J. M. BRUNT.

Copies of this patent may be obtained for five cents each, by addressing the "Commissioner of Patents,  
Washington, D. C."