

**(12) STANDARD PATENT**  
**(19) AUSTRALIAN PATENT OFFICE**

(11) Application No. **AU 2006201313 B2**

(54) Title  
**Method and apparatus for use in balancing ligaments of a knee**

(51) International Patent Classification(s)  
**A61B 17/56** (2006.01)

(21) Application No: **2006201313** (22) Date of Filing: **2006.03.29**

(30) Priority Data

(31) Number	(32) Date	(33) Country
<b>11/094,956</b>	<b>2005.03.31</b>	<b>US</b>

(43) Publication Date: **2006.10.19**

(43) Publication Journal Date: **2006.10.19**

(44) Accepted Journal Date: **2010.08.19**

(71) Applicant(s)  
**DePuy Products, Inc.**

(72) Inventor(s)  
**DiSilvestro, Mark R.**

(74) Agent / Attorney  
**Callinans, 1193 Toorak Road, Camberwell, VIC, 3124**

(56) Related Art  
**US 2005/0038442**  
**US 4899761**

ABSTRACT OF THE DISCLOSURE

5 An apparatus for use in performing an orthopaedic surgical procedure on a patient includes at least one femoral paddle and a tibial paddle. At least one of the femoral paddle and the tibial paddle is movable away from the other. The apparatus also includes a sensor configured to generate a signal indicative of a force applied to the femoral paddle or the tibial paddle. The apparatus may be communicatively coupled to a computer assisted orthopaedic surgery system.

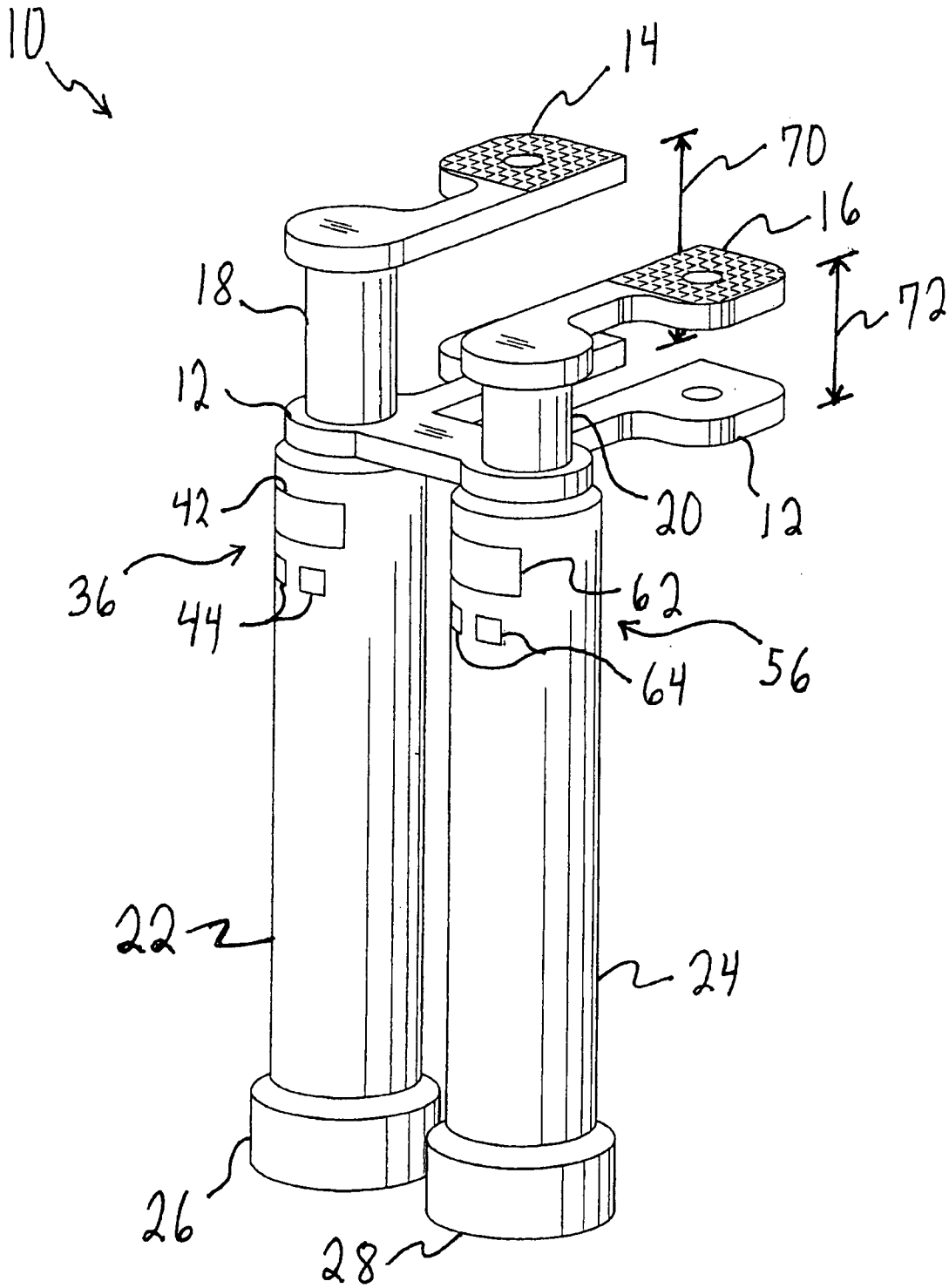

Fig. 2

**AUSTRALIA**

**Patents Act 1990**

**COMPLETE SPECIFICATION**

**FOR A STANDARD PATENT**

**ORIGINAL**

---

**TO BE COMPLETED BY APPLICANT**

**Name of Applicant:** DEPUY PRODUCTS, INC.

**Actual Inventor:** MARK R. DiSILVESTRO

**Address for Service:** CALLINAN LAWRIE, 711 High Street,  
Kew, Victoria 3101, Australia

**Invention Title:** METHOD AND APPARATUS FOR USE IN BALANCING  
LIGAMENTS OF A KNEE

The following statement is a full description of this invention, including the best method of performing it known to us:-

---

METHOD AND APPARATUS FOR USE IN  
BALANCING LIGAMENTS OF A KNEE

TECHNICAL FIELD

The present disclosure relates generally to methods and apparatus for use in  
5 the performance of orthopaedic procedures such as knee replacement procedures.

BACKGROUND

In some orthopaedic surgical procedures, such as a total knee  
replacement procedure, ligament balancing devices (commonly known as ligament  
10 balancers) may be used to balance the surrounding soft tissue (i.e., ligaments) of a  
patient's joint. For example, in a total knee replacement procedure, ligament  
balancing may be performed to ensure a generally rectangular shaped extension gap  
and a generally rectangular shaped flexion gap at a predetermined joint force value  
between the patient's natural or prosthetic proximal tibia and the patient's natural or  
15 prosthetic distal femur. To do so, a ligament balancer may be used to measure the  
medial and lateral joint forces and the medial and lateral gap distances when the  
patient's leg is in extension (i.e., the patient's tibia is positioned at about 0 degrees  
relative to the patient's femur) and in flexion (i.e., the patient's tibia is positioned at  
about 90 degrees relative to the patient's femur). In either extension or flexion, if the  
20 medial and lateral gap distances are not approximately equal (i.e., do not form a  
generally rectangular shaped joint gap) at the predetermined joint force value,  
ligament release may be performed to equalize the medial and/or lateral gap  
distances. A typical ligament balancer includes manually operated mechanical  
mechanisms, such as springs, to determine the joint force and to adjust the  
25 extension/flexion gap distance.

SUMMARY

According to one aspect, an apparatus for use in performing an  
orthopaedic surgical procedure on a patient is disclosed. The apparatus may include  
30 one or more femoral paddles configured to contact a natural or prosthetic distal  
femur of a patient. The apparatus may also include one or more tibial paddles

configured to contact a natural or prosthetic proximal tibia of the patient. At least one of the femoral paddle and/or the tibial paddle is movable away from the other. The apparatus may include a force sensor operatively coupled to the femoral paddle and/or the tibial paddle. The force sensor generates an output signal that is indicative of the magnitude of the force applied to the respective paddle. The apparatus may also include a distance sensor. The distance sensor generates an output signal that is indicative of the distance between the femoral and tibial paddles.

The apparatus may further include one or more controllers that determine a joint force value based on the output signal of the force sensor and a distance value based on the output signal of the distance sensor. The apparatus may also include a user interface and may display the force value and/or distance value to a user of the apparatus on the user interface via a display. The display may be a digital display, a series of LEDs, or the like. The apparatus may include actuators coupled to the paddles. The user may control the movement of the paddles by selecting an appropriate button from the user interface. In response, the controller controls the actuator to move the paddles. The apparatus may also transmit the force values and/or distance values to a computer assisted orthopaedic surgery system. In addition, the computer assisted orthopaedic surgery system may control functions of the apparatus by transmitting control and/or data signals to the controllers of the apparatus.

According to another aspect, a method for using a ligament balancer is disclosed. The method may include inserting the ligament balancer between a distal femur and a proximal tibia of the patient. The method may also include moving at least one of a femoral paddle and a tibia paddle away from the other paddle and generating an output signal that is indicative of a force applied to one of the paddles. The method may also include generating an output signal indicative of a

distance between the paddles. The output signals and/or values derived therefrom may be transmitted to a computer assisted orthopaedic surgery system.

In accordance with one aspect of the present invention, therefore, there is provided an apparatus for use in performing an orthopaedic surgical procedure on a patient, the apparatus including: a tibial paddle having spaced-apart medial and lateral portions configured to contact respective medial and lateral sides of a proximal tibia of the patient; a medial femoral paddle configured to contact a medial side of a distal femur of the patient and positioned over the tibial paddle; a lateral femoral paddle spaced-apart from the medial femoral paddle, configured to contact a lateral side of the distal femur of the patient and positioned over the tibial paddle; a housing, wherein the tibial paddle, the medial femoral paddle, and the lateral femoral paddle are each coupled to the housing; an actuator operatively coupled to the at least one of the medial femoral paddle and the lateral femoral paddle; a sensor configured to generate an electrical output signal indicative of a force applied to the at least one of the medial femoral paddle and the lateral femoral paddle; a user interface coupled to and positioned on the housing; and a controller, coupled to the housing and operable to (i) receive the electrical output signal from the sensor, (ii) determine a force value based on the electrical output signal, and (iii) display the force value on the user interface, the controller including a memory device operable to store a digital representation of the force value, wherein the controller is responsive to (i) a first user input received via the user interface to store the force value in the memory device and (ii) a second user input received via the user interface to retrieve the stored force value and control the actuator to move the at least one of the medial femoral paddle and the lateral femoral paddle away from the tibial paddle until the force applied to the at least one of the medial femoral paddle and the lateral femoral paddle is equal to the stored force value.

In accordance with yet another aspect of the present invention there is provided a ligament balancer including: a medial paddle configured to contact a medial side of a distal femur of a patient; a lateral paddle spaced-apart from the medial paddle and configured to contact a lateral side of the distal femur of the patient, wherein at least one of the medial and lateral paddles is configured to move in an inferior and a superior direction; a first electrically driven actuator configured

to move the medial paddle in the inferior direction and the superior direction; a second electrically driven actuator configured to move the lateral paddle in the inferior direction and the superior direction; a first sensor configured to generate a first electrical output signal indicative of a force applied to the medial paddle; a second sensor configured to generate a second electrical output signal indicative of a force applied to the lateral paddle; a housing, wherein the medial paddle and the lateral paddle are each coupled to the housing; a user interface coupled to and positioned on the housing; and a controller coupled to the housing and operable to (i) receive the first electrical output signal and the second electrical output signal, (ii) determine a first force value based on the first electrical output signal and a second force value based on the second electrical output signal, and (iii) display the first force value and the second force value on the user interface, wherein the controller is responsive to (i) a first user input received via the user interface to store the first force value, (ii) a second user input received via the user interface to store the second force value, and (iii) a third user input received via the user interface to retrieve the first stored force value to control the first actuator to move the medial paddle until the force applied to the medial paddle is equal to the first stored force value and retrieve the second stored value to control the second actuator to move the lateral paddle until the force applied to the lateral paddle is equal to the second stored force value.

In accordance with yet a further aspect of the present invention there is provided a ligament balancer including: a tibial paddle configured to contact a proximal tibia of a patient; a medial femoral paddle configured to contact a medial side a distal femur of the patient; a lateral femoral paddle spaced-apart from the medial femoral paddle and configured to contact a lateral side of the distal femur; a first electrically driven actuator operable to move the medial femoral paddle; a second electrically driven actuator operable to move the lateral femoral paddle; a first sensor configured to generate a first electrical output signal indicative of a distance between the medial femoral paddle and the tibial paddle; a second sensor configured to generate a second electrical output signal indicative of a distance between the lateral femoral paddle and the tibial paddle; a housing, wherein the medial femoral paddle, the lateral femoral paddle, and the tibial paddle are each

coupled to the housing; a user interface coupled to and positioned on the housing;  
and a controller coupled to the housing and operable to (i) receive the first electrical  
output signal and the second electrical output signal, (ii) determine a first distance  
value based on the first electrical output signal and a second distance value based on  
5 the second electrical output signal, and (iii) display the first distance value and the  
second distance value on the user interface, the controller including a memory device  
operable to store a digital representation of the first distance value and the second  
distance value, wherein the controller is responsive to (i) a first user input received  
via the user interface to store the first distance value and the second distance value in  
10 the memory device, and (ii) a second user input received via the user interface to  
retrieve the first stored distance value to control the first actuator to move the medial  
femoral paddle away from the tibial paddle to a distance equal to the first stored  
distance value and retrieve the second stored distance value to control the second  
actuator to move the lateral femoral paddle away from the tibial paddle to a distance  
15 equal to the second stored distance value.

In accordance with yet a further aspect of the present invention there is  
provided a ligament balancer including: a medial paddle configured to contact a  
medial side of a distal femur of a patient and movable in at least one of an inferior  
and a superior direction between a first and second medial position; a lateral paddle  
20 spaced-apart from the medial paddle, configured to contact a lateral side of the distal  
femur of the patient, and movable in at least one of an inferior and a superior  
direction between a first and second lateral position; an electrically driven actuator  
configured to move at least one of the medial and lateral paddles between the  
respective first and second medial and lateral positions in response to a control  
25 signal; a sensor configured to generate an electrical output signal indicative of a force  
applied to the at least one of the medial paddle and lateral paddle; a housing, wherein  
the medial paddle, the lateral paddle, and the electrically driven actuator, are each  
coupled to the housing; and a user interface coupled to and positioned on the  
housing; a controller coupled to the housing and operable to (i) receive the electrical  
30 output signal from the sensor, (ii) determine a force value based on the electrical  
output signal, and (iii) display the force value on the user interface, the controller  
including a memory device operable to store a digital representation of the force

value, wherein the controller is responsive to (i) a first user input received via the user interface to store the force value in the memory device and (ii) a second user input received via the user interface to retrieve the stored force value and control the actuator to move the at least one of the medial and lateral paddles until the force  
5 applied to the at least one of the medial and lateral paddles is equal to the stored force value.

The above and other features of the present disclosure, which alone or in any combination may comprise patentable subject matter, will become apparent from the following description and the attached drawings.

## BRIEF DESCRIPTION OF THE DRAWINGS

The detailed description particularly refers to the following figures, in which:

FIG. 1 is a perspective view of an electronic ligament balancer;

5 FIG. 2 is another perspective view of the ligament balancer of FIG. 1, note that the femoral paddles are positioned in different positions in FIG. 2;

FIG. 3 is a simplified block diagram of an electrical system of the ligament balancer of FIG. 1; and

10 FIG. 4 is a simplified block diagram of a computer assisted orthopaedic surgery system communicatively coupled to the ligament balancer of FIG. 1.

## DETAILED DESCRIPTION OF THE DRAWINGS

While the concepts of the present disclosure are susceptible to various  
15 modifications and alternative forms, specific exemplary embodiments thereof have been shown by way of example in the drawings and will herein be described in detail. It should be understood, however, that there is no intent to limit the concepts of the present disclosure to the particular forms disclosed, but on the contrary, the intention is to cover all modifications, equivalents, and alternatives falling within the  
20 spirit and scope of the invention as defined by the appended claims.

Referring to FIG. 1, a ligament balancer 10 for use in an orthopaedic surgical procedure includes a tibial paddle 12, a first femoral paddle 14, and a second femoral paddle 16. The femoral paddle 14 is positioned vertically over and movable away from the tibial paddle 12. Similarly, the femoral paddle 16 is positioned  
25 vertically over and movable away from the tibial paddle 12. The tibial paddle 12 is configured to contact a proximal tibia of the patient. As used herein, the term "proximal tibia" is intended to refer to the natural or prosthetic proximal end of a patient's tibia. The tibial paddle 12 may include a mounting slot or aperture 13 configured to receive additional instrumentation such as a flexion adapter, a Ranawat  
30 block, and/or an anterior/posterior resection guide. The femoral paddles 14, 16 are configured to contact a distal femur of the patient. As used herein, the term "distal femur" is intended to refer to the natural or prosthetic distal end of the patient's

femur. In use, one of the femoral paddles 14, 16 contacts the medial side of the patient's femur and the other femoral paddle 14, 16 contacts the lateral side of the patient's femur depending on which femur-tibia joint of the patient is being operated on. For the following description, it will be assumed that the ligament balancer 10 is being used on a patient's left knee. Accordingly, femoral paddle 14 and components associated therewith may be described hereinafter as medial femoral paddle 14 and components. Similarly, the femoral paddle 16 and components associated therewith may be described hereinafter as lateral femoral paddle 16 and components.

Each of the femoral paddles 14, 16 is coupled to respective cylinders 18, 20. The cylinders 18, 20 are extendable out of and retractable into respective housings 22, 24. In the illustrative example, the housings 22, 24 are secured to each other via the tibial paddle 12. The medial femoral paddle 14 may be moved away from or toward the tibia paddle 12 by extending or retracting the cylinder 18. The lateral femoral paddle 16 may be moved away from or toward the tibia paddle 12 by extending or retracting the cylinder 20. It should be appreciated that each femoral paddle 14, 16 is independently movable. For example, as illustrated in FIG. 2, the medial femoral paddle 14 may be moved away from the tibial paddle 12 to a distance 70 that is greater than a distance 72 that the lateral femoral paddle 16 is moved away from the tibial paddle 12. Although the femoral paddles 14, 16 are described herein as movable relative to the tibial paddle 12, it should be appreciated that in other embodiments the tibial paddle 12 may be movable rather than or in addition to the femoral paddles 14, 16.

Movement of the femoral paddles 14, 16 may be performed via manual or automated means. For example, in some embodiments, the ligament balancer 10 includes knobs 26, 28 operatively coupled, such as by a screw mechanism, to the cylinders 18, 20, respectively. By manually turning one or both knobs 26, 28 in a clockwise or counterclockwise direction, the cylinders 18, 20 may be extended from or retracted into the respective housings 18, 20 so as to move the femoral paddles 14, 16. In other embodiments, additional or alternative devices for manually moving the femoral paddles 14, 16 away from the tibial paddle 12 may be included. As will be described below in greater detail, in yet other embodiments,

such manual adjustment of the ligament balancer may be replaced or included with automated mechanisms.

5 The ligament balancer 10 includes a force sensor 30, a distance sensor 32, and an actuator 34 positioned in the housing 22. The ligament balancer 10 also includes a force sensor 50, a distance sensor 52, and an actuator 54 positioned in the housing 24. The force sensor 30 is operatively coupled to the cylinder 18 and generates an output signal, such as a voltage signal, indicative of a magnitude of force applied to the medial femoral paddle 14. The force sensor 50 is operatively coupled to the cylinder 20 and generates an output signal, such as a voltage signal, 10 indicative of a magnitude of force applied to the lateral femoral paddle 16. In one particular embodiment, the force sensors 30, 50 are embodied as a load cells, such as miniature load cells.

The distance sensor 32 generates an output signal indicative of a medial distance 70 (see FIG. 2) between the medial femoral paddle 14 and the tibial 15 paddle 12. The distance sensor 52 generates an output signal indicative of a lateral distance 72 (see FIG. 2) between the lateral femoral paddle 16 and the tibial paddle 12. In some embodiments, the distance sensors 32, 52 are electrical devices and generate electrical output signals indicative of the distances 70, 72, respectively. In other embodiments, the distance sensors 32, 52 may be replaced with mechanical 20 distance indicators that create visual signals indicative of the distances 70, 72. For example, the distance sensors 32, 52 may be replaced with indicator needles or other visual indicators coupled to the cylinders 18, 20, and each housing 22, 24 may include a distance scale associated with each needle from which the medial and lateral joint gap distances may be obtained based on the position of the respective 25 needle.

The actuator 34 is operatively coupled to the cylinder 18 and is operable to extend or retract the cylinder 18 in response to a corresponding control signal. Similarly, the actuator 54 is operatively coupled to the cylinder 20 and is operable to extend or retract the cylinder 20 in response to a corresponding control 30 signal. In one particular embodiment, the actuators 34, 54, are embodied as stepper motors. In another embodiment, the actuators 34, 54 are embodied as linear actuators. However, the actuators 34, 54 may be embodied as any prime mover

5 devices operable to extend or retract the cylinders 18, 20. Although the illustrative ligament balancer 10 includes the force sensors 30, 50, the distance sensors 32, 52, and the actuators, 34, 54, in some embodiments, the ligament balancer 10 may include only the force sensors 30, 50, only the distance sensors 32, 52, only the actuators, 34, 54, or any combination thereof.

10 The ligament balancer 10 illustrated in FIGS. 1 and 2 also includes a user interface 36, a controller 38, and a power supply 40 positioned on or in the housing 22. The ligament balancer 10 also includes a user interface 56, a controller 58, and a power supply 60 positioned on or in the housing 24. The user interface 36 may include a display screen 42 and a number of user buttons 44. Similarly, the user interface 56 may include a display screen 62 and a number of user buttons 64. In other embodiments, however, the display screens 42, 62 may be replaced with a series of light-emitting-diodes (LEDs) or a collection of visual indicators to provide simplified visual feedback to the user of the ligament balancer 10. Additionally, in  
15 some embodiments, the user interfaces 36, 56 may be replaced by a remote user interface(s) such as a user interface module that is separate from the housings 22, 24. In such an embodiment, the remote user interface(s) may communicate with the controllers 38, 58 via wired or wireless communication.

20 The controllers 38, 58 may be embodied as any type of controllers including, for example, general purpose micro-controllers, microprocessors, or application specific integrated circuits (ASICs). The power supplies 40, 60 may be embodied as any devices capable of supplying power to the other respective components such as controllers 38, 58, respectively. In one particular embodiment, the power supplies 40, 60 are embodied as replaceable batteries. In another  
25 embodiment, the power supplies 40, 60 are embodied as rechargeable battery packs. In such embodiments, the ligament balancer 10 may include appropriate charging contacts to allow the recharging of the battery packs. Although in the embodiment illustrated in FIG. 1, the ligament balancer 10 includes two user interfaces, two controllers, and two power supplies, it should be appreciated that in other  
30 embodiments the ligament balancer 10 may include only one user interface, one controller, and/or one power supply. For example, the ligament balancer 10 may include a single controller positioned in one of the housings 22, 24 and

communicatively coupled to each of the force sensors 30, 50, the distance sensors 32, 52, and the actuators 34, 54. Similarly, the ligament balancer 10 may include a single user interface that is communicatively coupled to each of the controllers 38, 58 (or to a single controller).

5 Referring now to FIG. 3, the interconnection of the components included in the medial housing 22 will be described below with the understanding that such description is also applicable to the components included in the lateral housing 24. In addition, it should be further understood that in some embodiments of the ligament balancer 10 only one controller, one user interface, and/or one power  
10 supply may be included. Again, the following description is applicable to such embodiments as well.

The controller 38 is communicatively coupled to the force sensor 30, the distance sensor 32, and the actuator 34 via a number of interconnects 80, 82, and 84, respectively. The interconnects 80, 82, 84 may be any type of interconnect  
15 capable of enabling communication between the sensor 30, the sensor 32, the actuator 34 and the controller 38 such as wires, printed-circuit-board (PCB) traces, wireless connections, and the like. In addition, the controller 38 is communicatively coupled to the user interface 36 via interconnects 86 and to the power supply 40 via  
20 interconnects 88. The controller 38 may further include a receiver, transmitter, or transceiver 90 and a memory device 92 such as a random access memory (RAM) device.

The controller 38 is configured with the appropriate hardware, software, and/or firmware to be responsive to the user commands received via the user interface 36. As such, a surgeon may interact with the ligament balancer 10 via  
25 the user interface 36 to control functions of the ligament balancer 10. For example, by use of one of the buttons 44 of the user interface 36, the surgeon can control the actuator 34 to move the medial femoral paddle 14 relative to the tibial paddle 12. In addition or alternatively to the user interface 36, in some embodiments, the surgeon may control the functions of the ligament balancer 10 (e.g., moving the femoral  
30 paddle 14) via voice commands. In such embodiments, the ligament balancer 10 may include a microphone or other device for receiving voice commands from the

surgeon. To facilitate such a feature, the controller 38 may include voice recognition software or devices to facilitate voice control of the ligament balancer 10.

In addition, the controller 38 receives measurement data from the force sensor 30 and the distance sensor 32 via the interconnects 80, 82, respectively.

5 The controller 38 may display the measurement data to the user via the user interface 36 and/or store the measurement data in the memory device 92 for later use. For example, while a patient's leg is positioned in extension, a surgeon may move the medial femoral paddle 14 away from the tibia paddle 12 until a predetermined medial joint force value is achieved as indicated by the force sensor 32 and displayed to the

10 surgeon via the user interface 36. The surgeon may then select one of the buttons 44 to cause the controller 38 to store the medial joint force value and/or the medial joint gap distance, as indicated by the output signal of the distance sensor 32, in the memory device 92. The surgeon may then position the patient's leg in flexion, reinsert the ligament balancer 10, and select another one of the buttons 44 to cause

15 the actuator 34 to move the medial femoral paddle 14 to a position having the same medial joint force as the stored medial joint force value. In this respect, actuation of the femoral paddles 14, 16 may be automated or semi-automated without direct control of the actuators 34, 54 by the user.

Referring now to FIG. 4, the controller 38 of the ligament balancer

20 apparatus 10 may be configured to communicate with an external controller, computer, or system such as a computer assisted orthopaedic surgery (CAOS) system 94 by use of the transceiver 90 (either wired or wirelessly). In one particular embodiment, the CAOS system 94 is embodied as a Ci<sup>TM</sup> system commercially available from Depuy Orthopaedics, Inc. of Warsaw, Indiana. The controller 38 may

25 communicate with the CAOS system 94 via a communication link 96. The communication link 96 may be any type of communication link including a wired or wireless communication link and may use any type of suitable communication technology and/or protocol including, but not limited to, Ethernet, USB, TCP/IP, Bluetooth, ZigBee, Wi-Fi, Wireless USB, and the like. One communication network

30 that may be used as the communication link 96 to enable wireless communication between the controller 38 and the CAOS system 94 is described in currently pending and commonly owned U.S. Patent Application No. 11/024,905 entitled "Medical

Device Communications Network”, which was filed on December 29, 2004, the entirety of which is expressly incorporated herein by reference.

In some embodiments, the controller 38 transmits measurement data received from the force sensor 30 and/or the distance sensor 32 to the CAOS system 94. The CAOS system 94 may then display the measurement data to the surgeon via a display device (not shown) such as a monitor or the like included in the CAOS system 94 to give the surgeon visual feedback as the surgeon is operating the ligament balancer 10. The CAOS system 94 may also use the measurement data in various calculations or algorithms to determine, for example, surgical suggestions, anatomical simulations resulting from a proposed surgical procedure or step, and the like.

In addition, the CAOS system 74 may communicate with the ligament balancer 10 to control functions of the ligament balancer 10. For example, while a patient’s leg is in positioned in extension, a surgeon may move the medial femoral paddle 14 and the lateral femoral paddle 16 away from the tibia paddle 12 until a predetermined medial and lateral joint force value is achieved as indicated by the force sensors 32, 52, respectively. The surgeon may then select one of the buttons 44 and/or one of the buttons 64 to transmit the medial/lateral joint force values and/or the medial/lateral joint gap distances to the CAOS system 94. The CAOS system 94 stores the values for later use. The surgeon may then position the patient’s leg in flexion, reinsert the ligament balancer 10, and interact with the CAOS system 94 (e.g., by selecting a button on the CAOS system 94, providing a verbal command to the CAOS system 94, or the like) to cause the CAOS system 94 to transmit control signals including the stored medial/lateral joint force values and/or the stored medial/lateral joint gap distances to the ligament balancer 10. In response, the controller 38 controls the actuator 34 to move the medial femoral paddle 14 to a position having the same medial joint force as the medial joint force value received from the CAOS system 94. Similarly, the controller 58 controls the actuator 54 to move the lateral femoral paddle 16 to a position having the same lateral joint force as the lateral joint force value received from the CAOS system 94. Accordingly, the system 94 may control the functions of the ligament balancer 10 while providing the surgeon with visual feedback data during the surgical procedure.

The ligament balancer 10 may be used to assist a surgeon in balancing ligaments of a knee of a patient. To do so, the patient's knee is positioned in extension (i.e., the patient's tibia is positioned at about 0 degrees relative to the patient's femur). The ligament balancer 10 is then inserted between the patient's  
5 distal femur and proximal tibia. Depending upon the surgical procedure being performed and/or the surgeon's general surgical practice, the ligament balancer 10 may be inserted prior to any resection of the bones of the knee, after resection, after knee replacement trials have been positioned on the respective bones, or after the permanent prosthetic knee replacement components have been implanted in the  
10 patient. Regardless, the ligament balancer 10 is positioned between the patient's femur and tibia such that the femoral paddles 14, 16 contact the natural or prosthetic distal femur and the tibial paddle 12 contacts the natural or prosthetic proximal tibial.

Once the ligament balancer is properly positioned, the surgeon may move the femoral paddles 14, 16 away from the tibial paddle 12 until a  
15 predetermined medial and lateral joint force is achieved. This may be accomplished manually by turning the knobs 26, 28 until the desired joint force value is achieved. Alternatively, this may be accomplished by selecting one of the buttons 44, 64 of the user interfaces 36, 56 to cause the actuators 34, 54 to move the femoral paddles 14, 16 until the desired joint force value is achieved. In some embodiments, this may  
20 also be accomplished by supplying the CAOS system 94 with the desired joint force value. In response, the CAOS system 94 transmits the appropriate control signals to the ligament balancer 10 to cause the actuators 34, 54 to move the femoral paddles 14, 16 away from the tibial paddle 12 until the desired joint force value is achieved.

Each of the femoral paddles 14, 16 may be moved separately and  
25 independently of each other. Because of irregularities in the patient's anatomy, the femoral paddles 14, 16 may need to be moved to different distances to achieve the same desired joint force value. If so, the extension gap (i.e., the gap between the distal femur and the proximal tibia when the knee is in extension) will not have a rectangular shape. Because a generally rectangular shaped extension gap is  
30 desirable, the surgeon may perform ligament release on one or more ligaments to allow the femoral paddles 14, 16 to be equally positioned while maintaining the desired joint force value.

It should be understood that as the surgeon is moving the femoral paddles 14, 16, the medial and lateral joint forces (i.e., the forces being applied to each paddle 14, 16) are determined by the force sensors 30, 50, respectively. The controller 38 calculates a force value based on the output signal of the force sensor 30 and displays the force value to the surgeon via the display 42 of the user interface 36. Similarly, the controller 58 calculates a force value based on the output signal of the force sensor 50 and displays the force value to the surgeon via the display 62 of the user interface 56. The force values displayed on the user interfaces 36, 56 may be numerical values or may be represented by a number of LEDs. In some embodiments, the distance 70 which the medial femoral paddles 14 is moved away from the tibial paddle 12 is determined by the distance sensor 32 and also displayed to the surgeon via the user interface 36. Similarly, the distance 72 which the lateral femoral paddles 16 is moved away from the tibial paddle 12 is determined by the distance sensor 52 and also displayed to the surgeon via the user interface 56. Further, in some embodiments, the force values and/or distance values may be transmitted to the CAOS system 94. The CAOS system 94 may display the force and/or distance values to the surgeon to provide a visual feedback to the surgeon as the surgeon is manipulating the femoral paddles 14, 16. Further, the CAOS system 94 may have additional sensors or devices to determine when the desirable rectangular shaped extension gap is achieved and alert the user to such (e.g., by an audible or visual alert).

In addition to displaying the force values and distance values to the surgeon, the controllers 38, 58 may store the values for later use. For example, once the surgeon has moved the medial femoral paddle 14 to achieve the desired medial joint force value, the surgeon may select one of the buttons 44 to cause the controller 38 to store the medial joint force value and, in some embodiments, the distance 70 at which the medial femoral paddle 14 is moved away from the tibial paddle 12. Similarly, once the surgeon has moved the lateral femoral paddle 16 to achieve the desired lateral joint force value, the surgeon may select one of the buttons 64 to cause the controller 58 to store the lateral joint force value and, in some embodiments, the distance 72 at which the lateral femoral paddle 16 is moved away

from the tibial paddle 12. In addition or alternatively, the CAOS system 94 may store the joint force values and/or distance values for later use.

5 After the surgeon has achieved the desired extension gap and performed any necessary ligament release, the femoral paddles 14, 16 are moved toward the tibial paddle 12 so that the ligament balancer 10 may be removed from the patient's knee joint. The patient's knee is then positioned in flexion (i.e., the patient's tibia is positioned at about 90 degrees relative to the patient's femur) and the ligament balancer 10 is reinserted between the patient's distal femur and proximal tibia. The femoral paddles 14, 16 are again moved away from the tibia  
10 paddle 12 until the desired medial and lateral joint force values are achieved. To do so, the surgeon may select one of the buttons 44 of the user interface 36 to move the medial femoral paddle 14 away from the tibial paddle 12 until the desired medial joint force value, as determined by the force sensor 30, is achieved. Similarly, the surgeon may select one of the buttons 64 of the user interface 56 to move the lateral  
15 femoral paddle 16 away from the tibial paddle 12 until the desired lateral joint force value, as determined by the force sensor 50, is achieved. Typically, it is desirable to use the same force value for both the flexion joint force and the extension joint force.

In another embodiment, the surgeon may select another one of the buttons 44 to cause the controller 38 to retrieve the stored medial joint force value  
20 from memory. The controller 38 then controls the actuator 34 to move the medial femoral paddle 14 away from the tibial paddle 12 until the medial joint force, as measured by the joint force sensor 30, equals the retrieved medial joint force value. Similarly, the surgeon may select another one of the buttons 64 to cause the controller 58 to retrieve the stored lateral joint force value from memory. The  
25 controller 58 then controls the actuator 54 to move the lateral femoral paddle 16 away from the tibial paddle 12 until the lateral joint force, as measured by the joint force sensor 50, equals the retrieved lateral joint force value.

In yet another embodiment, the CAOS system 94 controls the movement of the femoral paddles 14, 16 by transmitting control signals to the  
30 respective controllers, 38, 58. For example, after the ligament balancer 10 has been reinserted into the knee area of the patient, the surgeon may press another button on the user interface 36 and/or on the user interface 56 to cause the controllers 38, 58 to

send a ready signal to the CAOS system 94 informing the CAOS system 94 that the ligament balancer 10 is ready to receive control signals. In response to the ready signal, the CAOS system 94 retrieves the stored medial and lateral joint force values from memory and transmits the retrieved values to the respective controllers 38, 50.

5 The controller 38 then controls the actuator 34 to move the medial femoral paddle 14 away from the tibial paddle 12 until the medial joint force, as measured by the joint force sensor 30, equals the received medial joint force value. The controller 58 controls the actuator 54 to move the lateral femoral paddle 16 away from the tibial paddle 12 until the lateral joint force, as measured by the joint force sensor 50, equals  
10 the received lateral joint force value.

In yet a further embodiment, the surgeon may control the movement of the femoral paddles 14, 16 via the CAOS system 94 rather than the respective user interfaces 36, 56. For example, the user may enter in a desired joint force value into the CAOS system 94. In response, the CAOS system 94 communicates the entered  
15 joint force value to the ligament balancer 10 to cause the movement of the femoral paddles 14, 16 until the desired joint force value is achieved.

Once the femoral paddles 14, 16 have been moved to the appropriate positions to achieve the desired joint force values, the surgeon may, if desirable, perform any necessary ligament release, as described above, to develop a more  
20 rectangular shaped flexion gap. After the ligament release is preformed, the femoral paddles 14, 16 are moved toward the tibial paddle 12 and the ligament balancer 10 is removed from the knee area of the patient.

Although the ligament balancer 10 has been described herein in reference to a knee joint of a patient, it should be understood that the ligament  
25 balancer 10 may be used on other joints of the patient. For example, the ligament balancer 10 may be used on an elbow joint of the patient. As such, it should be appreciated that although some of the components have been described in reference to certain bones of the patient (e.g., femoral and tibial paddles), such components would be configured to be used on or with the appropriate bones of the patient's joint  
30 being operated on.

While the disclosure has been illustrated and described in detail in the drawings and foregoing description, such an illustration and description is to be

2006201313 29 Mar 2006

considered as exemplary and not restrictive in character, it being understood that only illustrative embodiments have been shown and described and that all changes and modifications that come within the spirit of the disclosure are desired to be protected.

5                   There are a plurality of advantages of the present disclosure arising from the various features of the apparatuses, systems, and methods described herein. It will be noted that alternative embodiments of the apparatuses, systems, and methods of the present disclosure may not include all of the features described yet still benefit from at least some of the advantages of such features. Those of ordinary  
10 skill in the art may readily devise their own implementations of the systems and methods that incorporate one or more of the features of the present invention and fall within the spirit and scope of the present disclosure as defined by the appended claims.

The claims defining the invention are as follows:

1. An apparatus for use in performing an orthopaedic surgical procedure on a patient, the apparatus including: a tibial paddle having spaced-apart medial and lateral portions configured to contact respective medial and lateral sides of a proximal tibia of the patient; a medial femoral paddle configured to contact a medial side of a distal femur of the patient and positioned over the tibial paddle; a lateral femoral paddle spaced-apart from the medial femoral paddle, configured to contact a lateral side of the distal femur of the patient and positioned over the tibial paddle; a housing, wherein the tibial paddle, the medial femoral paddle, and the lateral femoral paddle are each coupled to the housing; an actuator operatively coupled to the at least one of the medial femoral paddle and the lateral femoral paddle; a sensor configured to generate an electrical output signal indicative of a force applied to the at least one of the medial femoral paddle and the lateral femoral paddle; a user interface coupled to and positioned on the housing; and a controller, coupled to the housing and operable to (i) receive the electrical output signal from the sensor, (ii) determine a force value based on the electrical output signal, and (iii) display the force value on the user interface, the controller including a memory device operable to store a digital representation of the force value, wherein the controller is responsive to (i) a first user input received via the user interface to store the force value in the memory device and (ii) a second user input received via the user interface to retrieve the stored force value and control the actuator to move the at least one of the medial femoral paddle and the lateral femoral paddle away from the tibial paddle until the force applied to the at least one of the medial femoral paddle and the lateral femoral paddle is equal to the stored force value.
2. The apparatus of claim 1, wherein the actuator is a stepper motor.
3. The apparatus of claim 1, wherein the actuator is a linear actuator.
4. The apparatus of any one of claims 1 to 3, wherein the sensor is a load cell.

5. The apparatus of any one of claims 1 to 4, further including a distance sensor configured to generate a distance signal indicative of a distance between at least one of the medial and lateral femoral paddles and the tibial paddle.

6. The apparatus of any one of claims 1 to 5, wherein the user interface  
5 includes a number of buttons.

7. The apparatus of any one of claims 1 to 6, wherein the user interface includes a display.

8. The apparatus of any one of claims 1 to 4, 6 or 7, further including a  
10 distance sensor configured to generate an electrical distance signal indicative of a distance between at least one of the medial and lateral femoral paddles and the tibial paddle, and wherein the controller is configured to (i) receive the electrical distance signal, (ii) determine a distance value based on the electrical distance signal, and (iii) display the distance value on the user interface.

9. The apparatus of any one of the preceding claims, wherein the controller  
15 includes a memory device and is configured to store a digital representation of the distance signal.

10. The apparatus of claim 9, wherein the controller is responsive to a user input received via the user interface to retrieve a stored distance value from the memory device and control the means for moving the at least one of the medial  
20 femoral paddle, the lateral femoral paddle and the tibial paddle to move the at least one of the medial femoral paddle and the lateral femoral paddle away from the tibial paddle to a distance equal to the stored distance value.

11. The apparatus of any one of the preceding claims, further including a transmitter configured to transmit measurement data.

12. The apparatus of claim 11, wherein the measurement data includes data  
25 indicative of the force applied to at least one of the medial and lateral femoral paddles.

13. The apparatus of claim 11 or claim 12, wherein the measurement data includes data indicative of a distance between at least one of the medial and lateral femoral paddles and the tibial paddle.

14. The apparatus of any one of the preceding claims, further including a receiver configured to receive control signals from a computer assisted orthopaedic surgical system.

15. The apparatus of claim 14, further including a second controller communicatively coupled to the receiver and configured to control the actuator in response to the control signals.

16. A ligament balancer including: a medial paddle configured to contact a medial side of a distal femur of a patient; a lateral paddle spaced-apart from the medial paddle and configured to contact a lateral side of the distal femur of the patient, wherein at least one of the medial and lateral paddles is configured to move in an inferior and a superior direction; a first electrically driven actuator configured to move the medial paddle in the inferior direction and the superior direction; a second electrically driven actuator configured to move the lateral paddle in the inferior direction and the superior direction; a first sensor configured to generate a first electrical output signal indicative of a force applied to the medial paddle; a second sensor configured to generate a second electrical output signal indicative of a force applied to the lateral paddle; a housing, wherein the medial paddle and the lateral paddle are each coupled to the housing; a user interface coupled to and positioned on the housing; and a controller coupled to the housing and operable to (i) receive the first electrical output signal and the second electrical output signal, (ii) determine a first force value based on the first electrical output signal and a second force value based on the second electrical output signal, and (iii) display the first force value and the second force value on the user interface, wherein the controller is responsive to (i) a first user input received via the user interface to store the first force value, (ii) a second user input received via the user interface to store the second force value, and (iii) a third user input received via the user interface to retrieve the first stored force value to control the first actuator to move the medial paddle until the force applied to the medial paddle is equal to the first stored force value and

retrieve the second stored value to control the second actuator to move the lateral paddle until the force applied to the lateral paddle is equal to the second stored force value.

5 17. A ligament balancer including: a tibial paddle configured to contact a proximal tibia of a patient; a medial femoral paddle configured to contact a medial side a distal femur of the patient; a lateral femoral paddle spaced-apart from the medial femoral paddle and configured to contact a lateral side of the distal femur; a first electrically driven actuator operable to move the medial femoral paddle; a second electrically driven actuator operable to move the lateral femoral paddle; a  
10 first sensor configured to generate a first electrical output signal indicative of a distance between the medial femoral paddle and the tibial paddle; a second sensor configured to generate a second electrical output signal indicative of a distance between the lateral femoral paddle and the tibial paddle; a housing, wherein the medial femoral paddle, the lateral femoral paddle, and the tibial paddle are each  
15 coupled to the housing; a user interface coupled to and positioned on the housing; and a controller coupled to the housing and operable to (i) receive the first electrical output signal and the second electrical output signal, (ii) determine a first distance value based on the first electrical output signal and a second distance value based on the second electrical output signal, and (iii) display the first distance value and the  
20 second distance value on the user interface, the controller including a memory device operable to store a digital representation of the first distance value and the second distance value, wherein the controller is responsive to (i) a first user input received via the user interface to store the first distance value and the second distance value in the memory device, and (ii) a second user input received via the user interface to  
25 retrieve the first stored distance value to control the first actuator to move the medial femoral paddle away from the tibial paddle to a distance equal to the first stored distance value and retrieve the second stored distance value to control the second actuator to move the lateral femoral paddle away from the tibial paddle to a distance equal to the second stored distance value.

30 18. A ligament balancer including: a medial paddle configured to contact a medial side of a distal femur of a patient and movable in at least one of an inferior

and a superior direction between a first and second medial position; a lateral paddle spaced-apart from the medial paddle, configured to contact a lateral side of the distal femur of the patient, and movable in at least one of an inferior and a superior direction between a first and second lateral position; an electrically driven actuator  
5 configured to move at least one of the medial and lateral paddles between the respective first and second medial and lateral positions in response to a control signal; a sensor configured to generate an electrical output signal indicative of a force applied to the at least one of the medial paddle and lateral paddle; a housing, wherein the medial paddle, the lateral paddle, and the electrically driven actuator, are each  
10 coupled to the housing; and a user interface coupled to and positioned on the housing; a controller coupled to the housing and operable to (i) receive the electrical output signal from the sensor, (ii) determine a force value based on the electrical output signal, and (iii) display the force value on the user interface, the controller including a memory device operable to store a digital representation of the force  
15 value, wherein the controller is responsive to (i) a first user input received via the user interface to store the force value in the memory device and (ii) a second user input received via the user interface to retrieve the stored force value and control the actuator to move the at least one of the medial and lateral paddles until the force applied to the at least one of the medial and lateral paddles is equal to the stored  
20 force value.

19. The ligament balancer of any one of claims 16 to 18, wherein the electrically driven actuator is a stepper motor.

20. The ligament balancer of any one of claims 16 to 18, wherein the electrically driven actuator is a linear actuator.

25 21. An apparatus for use in performing an orthopaedic surgical procedure on a patient, substantially as described herein with reference to the accompanying drawings.

22. A ligament balancer, substantially as described herein with reference to the accompanying drawings.



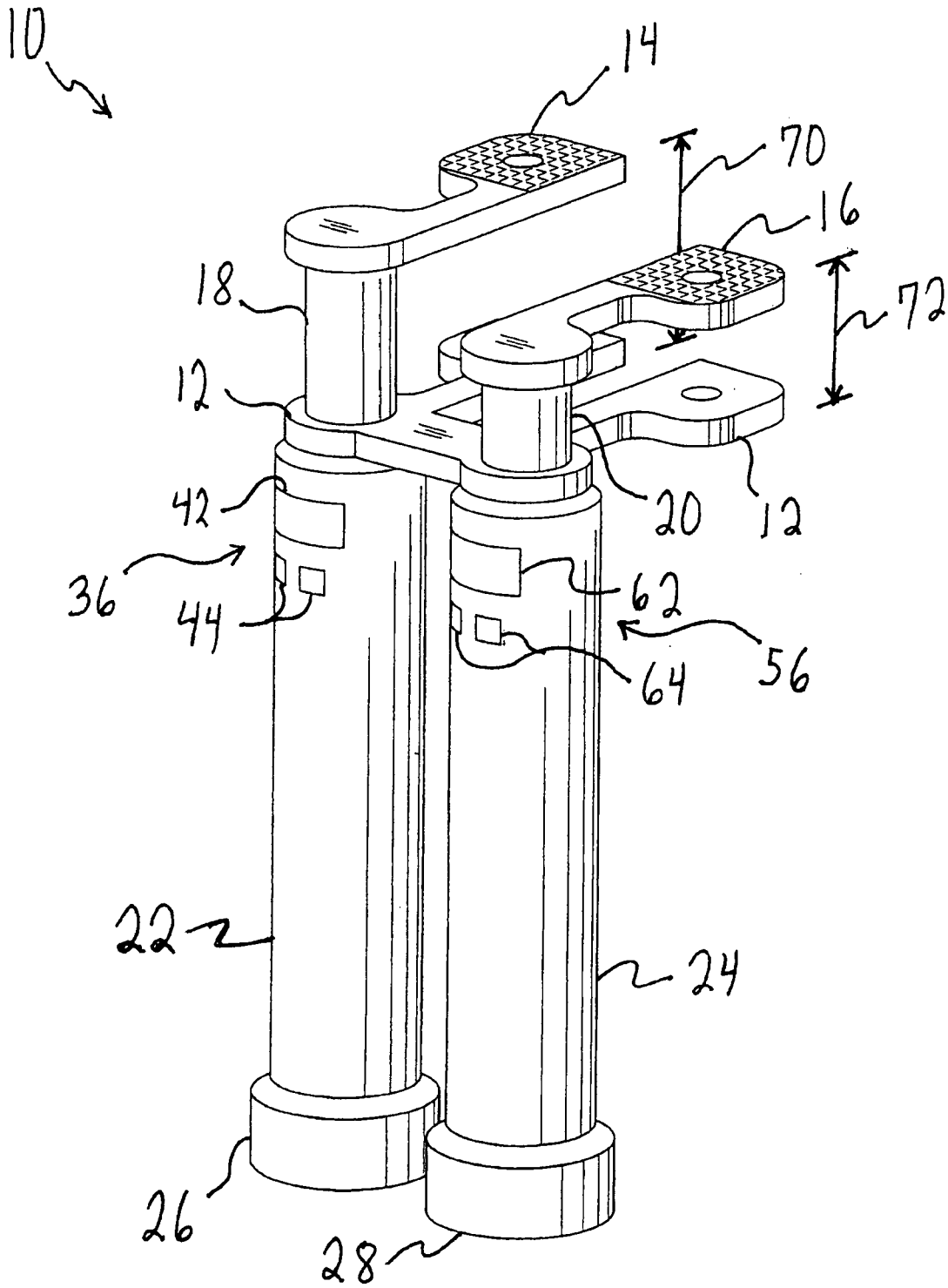

Fig. 2

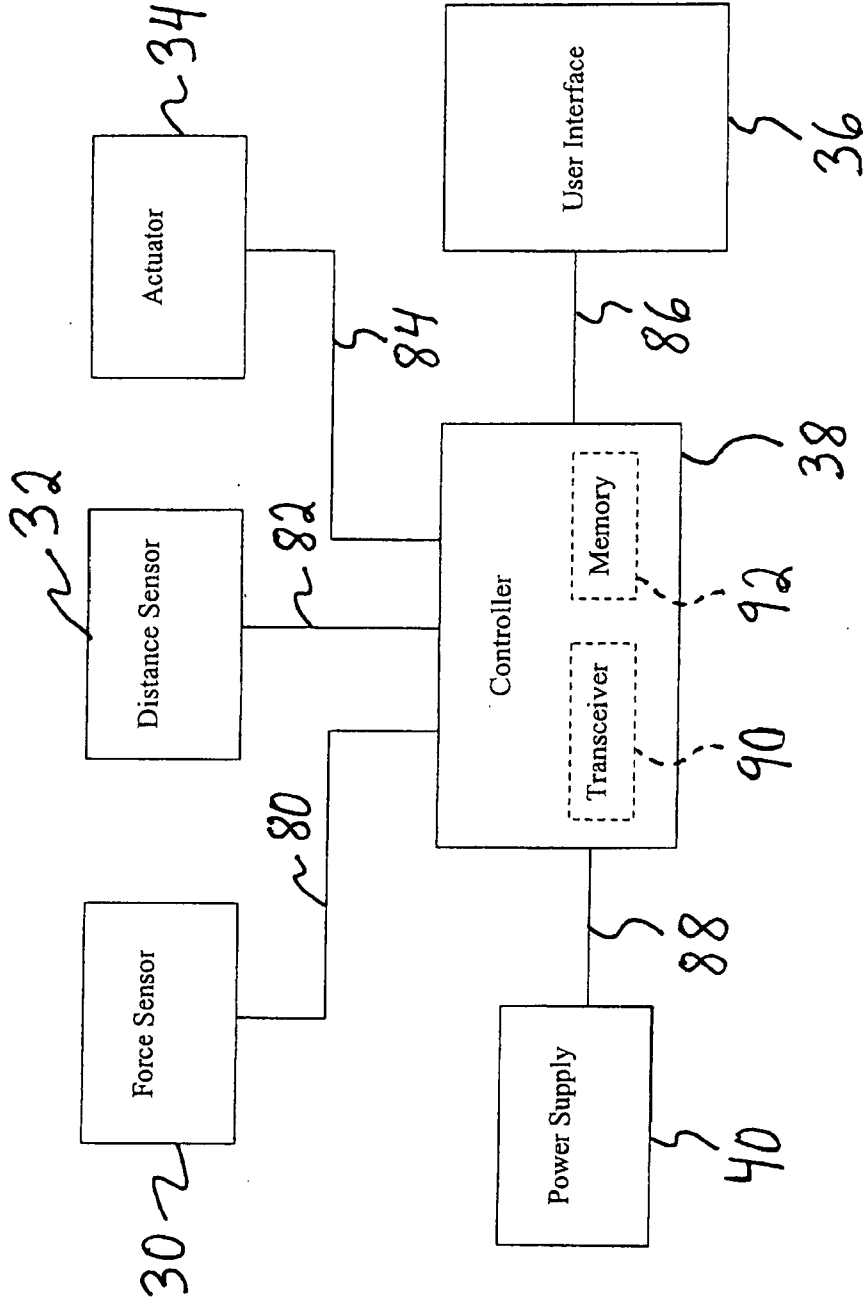

Fig. 3

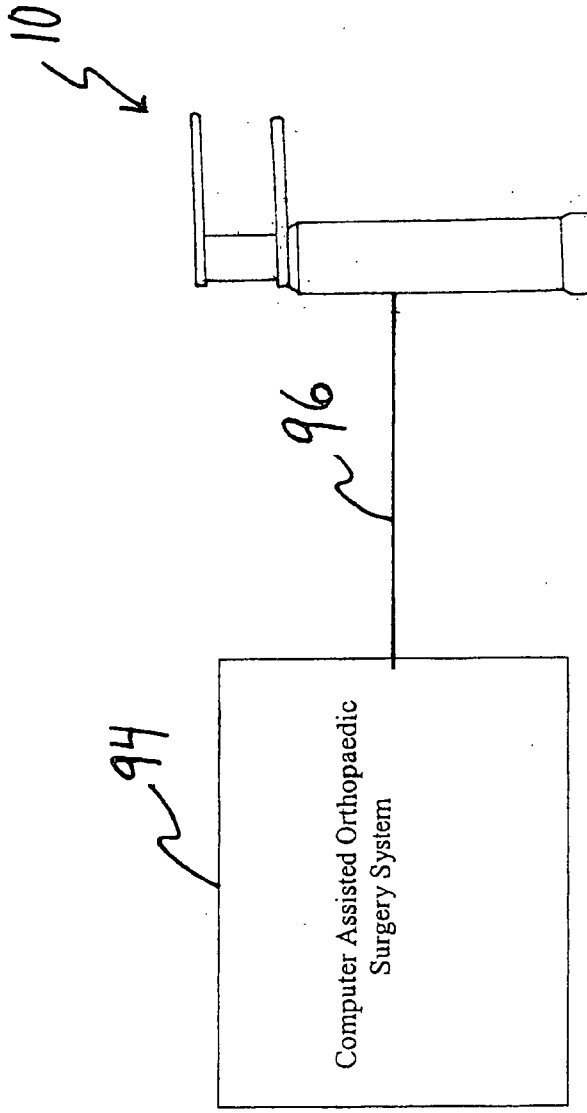

Figure 4