

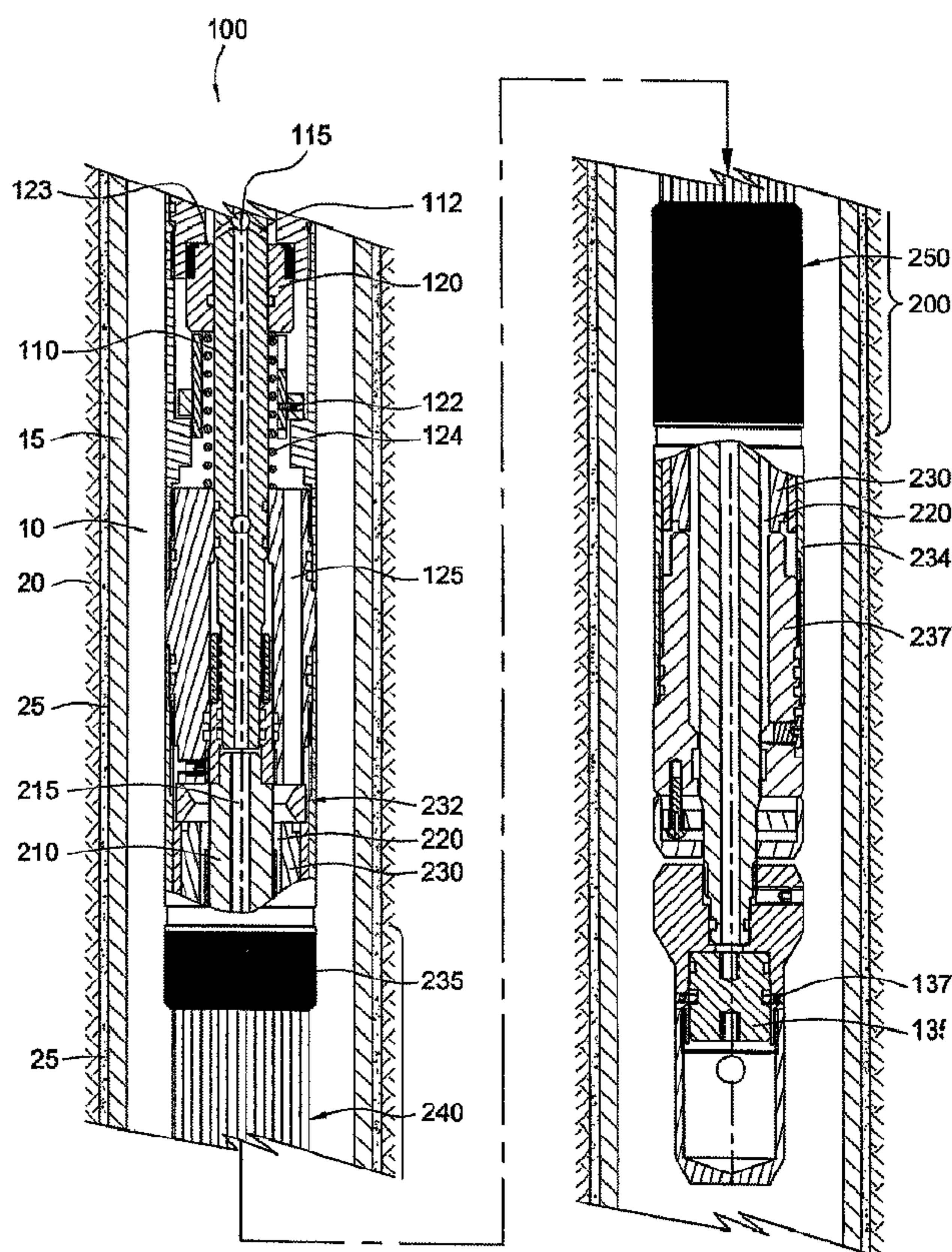

(86) Date de dépôt PCT/PCT Filing Date: 2003/01/15  
 (87) Date publication PCT/PCT Publication Date: 2003/07/31  
 (45) Date de délivrance/Issue Date: 2007/05/29  
 (85) Entrée phase nationale/National Entry: 2004/07/15  
 (86) N° demande PCT/PCT Application No.: US 2003/001181  
 (87) N° publication PCT/PCT Publication No.: 2003/062593  
 (30) Priorités/Priorities: 2002/01/16 (US60/350,183);  
 2003/01/15 (US10/346,015)

(51) Cl.Int./Int.Cl. *E21B 33/127* (2006.01),  
*E21B 33/12* (2006.01), *E21B 33/1295* (2006.01)  
 (72) Inventeurs/Inventors:  
 WILSON, PAUL J., US;  
 HOFFMAN, COREY E., US  
 (73) Propriétaire/Owner:  
 WEATHERFORD/LAMB, INC., US  
 (74) Agent: DEETH WILLIAMS WALL LLP

(54) Titre : ELEMENT D'EMBALLAGE GONFLABLE  
 (54) Title: INFLATABLE PACKING ELEMENT



(57) Abrégé/Abstract:

An inflatable packing element for a bridge plug. The packing element has an anchor portion and a sealing cover portion, each of which is expanded in order to engage and seal a surrounding string of casing or borehole. The anchor portion has a minimum length defined by  $2.63 \times$  the inner diameter of the surrounding pipe or other wellbore opening. At the same time, the anchor portion has a maximum length defined by approximately 49% of the length of the expanded portion of the packing element engaging the surrounding pipe or other wellbore opening.

## (12) INTERNATIONAL APPLICATION PUBLISHED UNDER THE PATENT COOPERATION TREATY (PCT)

(19) World Intellectual Property Organization  
International Bureau(43) International Publication Date  
31 July 2003 (31.07.2003)

PCT

(10) International Publication Number  
WO 03/062593 A1

- (51) International Patent Classification<sup>7</sup>: E21B 33/127, 33/12, 33/1295
- (72) Inventors: WILSON, Paul, J.; 3911 Pinesbury, Houston, TX 77084 (US). HOFFMAN, Corey, E.; 10423 Creswater Circle, Magnolia, TX 77384 (US).
- (21) International Application Number: PCT/US03/01181
- (74) Agent: PATTERSON, William, B.; 3040 Post Oak Boulevard, Suite 1500, Houston, TX 77056 (US).
- (22) International Filing Date: 15 January 2003 (15.01.2003)
- (25) Filing Language: English
- (81) Designated States (*national*): AE, AG, AL, AM, AT, AU, AZ, BA, BB, BG, BR, BY, BZ, CA, CH, CN, CO, CR, CU, CZ, DE, DK, DM, DZ, EC, EE, ES, FI, GB, GD, GE, GH, GM, HR, HU, ID, IL, IN, IS, JP, KE, KG, KP, KR, KZ, LC, LK, LR, LS, LT, LU, LV, MA, MD, MG, MK, MN, MW, MX, MZ, NO, NZ, OM, PH, PL, PT, RO, RU, SC, SD, SE, SG, SK, SL, TJ, TM, TN, TR, TT, TZ, UA, UG, UZ, VC, VN, YU, ZA, ZM, ZW.
- (26) Publication Language: English
- (30) Priority Data:  
60/350,183 16 January 2002 (16.01.2002) US  
00/000,000 15 January 2003 (15.01.2003) US
- (71) Applicant: WEATHERFORD/LAMB, INC. [US/US]; 515 Post Oak Boulevard, Suite 600, Houston, TX 77027 (US).
- (84) Designated States (*regional*): ARIPO patent (GH, GM, KE, LS, MW, MZ, SD, SL, SZ, TZ, UG, ZM, ZW), Eurasian patent (AM, AZ, BY, KG, KZ, MD, RU, TJ, TM),

[Continued on next page]

(54) Title: INFLATABLE PACKING ELEMENT

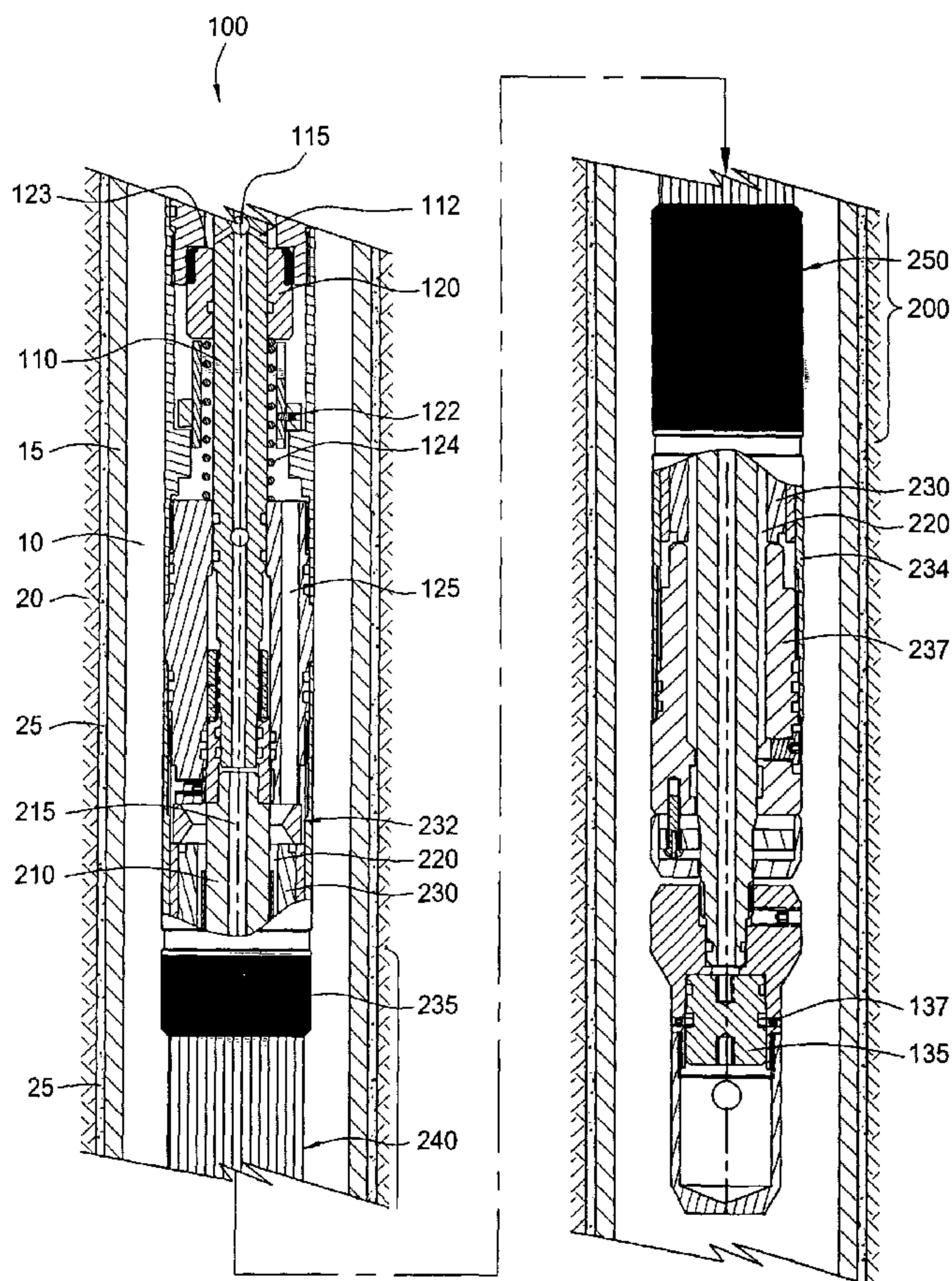

(57) Abstract: An inflatable packing element for a bridge plug. The packing element has an anchor portion and a sealing cover portion, each of which is expanded in order to engage and seal a surrounding string of casing or borehole. The anchor portion has a minimum length defined by  $2.63 \times$  the inner diameter of the surrounding pipe or other wellbore opening. At the same time, the anchor portion has a maximum length defined by approximately 49% of the length of the expanded portion of the packing element engaging the surrounding pipe or other wellbore opening.

  
WO 03/062593 A1

**WO 03/062593 A1**



European patent (AT, BE, BG, CH, CY, CZ, DE, DK, EE, ES, FI, FR, GB, GR, HU, IE, IT, LU, MC, NL, PT, SE, SI, SK, TR), OAPI patent (BF, BJ, CF, CG, CI, CM, GA, GN, GQ, GW, ML, MR, NE, SN, TD, TG).

— *before the expiration of the time limit for amending the claims and to be republished in the event of receipt of amendments*

**Published:**

— *with international search report*

*For two-letter codes and other abbreviations, refer to the "Guidance Notes on Codes and Abbreviations" appearing at the beginning of each regular issue of the PCT Gazette.*

## **INFLATABLE PACKING ELEMENT**

This new application for letters patent claims priority from an earlier-filed provisional patent application entitled "Inflatable Packer Element." That application was filed on January 16, 2002 and was assigned Application No. 60/350,183.

### **Field of the Invention**

The present invention generally relates to downhole tools for use in a wellbore. More particularly, the invention relates to a downhole tool for sealing a wellbore, such as a hydrocarbon wellbore. More particularly still, the invention relates to an inflatable sealing element for a downhole tool used for sealing a hydrocarbon wellbore.

### **Description of the Related Art**

In the drilling of oil and gas wells, a wellbore is formed using a drill bit that is urged downwardly at a lower end of a drill string. After drilling a predetermined depth, the drill string and bit are removed, and the wellbore is lined with a string of casing. An annular area is thus formed between the string of casing and the formation. A cementing operation is then conducted in order to fill the annular area with cement. The combination of cement and casing strengthens the wellbore and facilitates the isolation of certain areas of the formation behind the casing for the production of hydrocarbons.

After a well has been drilled and completed, it is desirable to provide a flow path for hydrocarbons from the surrounding formation into the newly formed wellbore. To accomplish this, perforations are shot through the liner string at a depth which equates to the anticipated depth of hydrocarbons. Alternatively, a liner having pre-formed slots may be run into the hole as casing. Alternatively still, a lower portion of the wellbore may remain uncased so that the formation and fluids residing therein remain exposed to the wellbore.

When a wellbore is completed, the wellbore is opened for production. In some instances, a string of production tubing is run into the wellbore to facilitate the flow of hydrocarbons to the surface. In this instance, it is common to deploy one or more packers within the tubing string in order to seal the annular region defined between

the tubing and the surrounding string of casing. In this way, a producing zone within the wellbore is isolated.

Various types of packers may be utilized. One common type of packer is an inflatable packer. Inflatable packers employ an elongated bladder that is inflated using a working fluid or well fluids. Inflation may be accomplished either by injecting fluid into the borehole from the surface, or through actuation of a downhole pump.

Inflatable packers are commonly used to seal the annular space around a string of production tubing in order to direct the flow of production fluids up the bore of the tubing and to the surface. However, inflatable packers may be used for many other purposes during the life of a well. For example, an inflatable well packer may be used to seal the annulus between a liner string and a surrounding string of casing during well completion. They may be used to support a column of cement above a lost circulation zone. They may also be used to isolate producing zones from cement contact during a cement squeeze job.

An inflatable packer may also be used to affect a complete seal of a tubular bore at a selected depth in a wellbore. In this instance, the inflatable packer is more commonly known as a bridge plug. In some instances, a bridge plug may be used to permanently plug a well after production operations have ceased. In other instances, a wellbore may be temporarily plugged so that formation treatment operations may be conducted. For example, a bridge plug may be set at a depth below a production zone within the casing. A formation treating operation can then be conducted above the bridge plug by injecting gel and sand, under pressure, into the formation. Still other uses for packers are also known, including dual use as an anchor.

For purposes of this disclosure, the term "bridge plug" will be used to refer to and to include any downhole tool which includes an expandable bladder as part of a sealing element, or "packing element." This includes devices having a through-bore that would more commonly be considered "packers."

The bladder in a typical inflatable bridge plug is surrounded by two separate expandable cover portions. The first cover portion is an expandable anchor; the second cover portion is an expandable sealing cover. Together, the bladder and the two surrounding cover portions make up a "packing element."

First, the expandable anchor portion of a packing element serves to frictionally engage the surrounding case or, as the case may be, the raw borehole. Typically, the anchor portion defines a series of vertically overlaid reinforcing straps that are exposed to the surrounding casing. The straps are aligned along the linear plane of the tool so as to essentially run the length of the packing element. At the same time, the straps are placed radially around the bladder in a tightly overlapping fashion. For this reason, the straps are sometimes referred to as "lapped steel ribs". The ends of the metal straps are welded together and are secured to end collars. One end collar defines a slidable sub which permits that end to be drawn up as the reinforcing straps are expanded. Upon expansion, the straps engage the surrounding pipe, serving to anchor the bridge plug within the wellbore. Sufficient straps are employed so that as the bladder expands the straps, the straps do not completely separate, but retain the bladder therein.

As an alternative to the use of metal straps, woven or braided steel cable may be used. In the case of a braided cable reinforcement, a closed tube of braided material is secured at opposite ends to packer end collars. A compression assembly is provided between a pair of conical clamping surfaces for securing the cables. In some cases, the end attachment of braided reinforcement is supplemented by injection of an epoxy polymer between the interstices of cable and the conical clamping surfaces.

As noted, the second cover portion of the inflatable bridge plug is the expandable sealing cover. The sealing cover defines a pliable material which surrounds a portion of the reinforcing straps (or other anchor portion). As the bladder and straps are expanded, the sealing cover expands and engages the surrounding pipe in order to effectuate a fluid seal. Thus, the anchor portion and the sealing cover portion of

the packing element combine to effectuate a setting and sealing function for the bridge plug.

Inflatable bridge plugs enjoy certain advantages over mechanically set bridge plugs / packers. Primarily, inflatable bridge plugs are advantageous in the context of high expansion operations. In this respect, most inflatable bridge plugs are capable of achieving a higher expansion ratio than mechanically set bridge plugs and packers. Those of ordinary skill in the art will understand that the expansion ratio is defined by the ratio of the inside diameter of the surrounding pipe to the original outside diameter, i.e., running diameter, of the packing element. However, high expansion applications (typically those greater than 2.25:1) place challenges on the designer to balance the anchoring and sealing capabilities of the packing element. In this regard, a trade-off oftentimes occurs in the design of a bridge plug between a high sealing capability and a high anchoring capability. A higher expansion ratio typically affords a greater anchoring capacity for the straps; in contrast, a lower expansion ratio provides for a weaker anchoring contact between the straps and the surrounding pipe.

In an effort to accomplish both a strong anchoring function and a strong sealing function for an inflatable bridge plug, designers have offered various configurations for the packing element. For example, in one arrangement an elongated sealing cover is provided, with the sealing cover being open or "exposed" central to the anchor. In this arrangement, the anchor portion is located in the center of the packing element. However, because the anchor portion is short relative to the sealing cover portion, this arrangement compromises the maximum anchoring capability of the bridge plug. In this respect, due to the shape change that occurs in the element under load, the short anchor in the center of the element will not distribute the applied differential load through the anchor to the pipe wall as efficiently as an anchor placed toward the end of the packing element. The shape change can occur because the inner mandrel within the bladder and the control valve tends to "float" along the central line of the packing element, allowing the bottom of the packing element to slide along the mandrel. Contact to the pipe wall is made via the reinforcing metal strap and rubber cover. As load is applied to the

packing element from below, the element can bunch up. In contrast, as load is applied from above, the element tends to morph from a circular cylinder shape to a teardrop shape. Hence, the metal reinforcing straps do not uniformly bite into the surrounding pipe. However, this arrangement does provide an optimum seal with the surrounding pipe wall due to the long rubber cover on either side of the anchor.

In an effort to overcome the problem of the short center anchor, some have offered a long anchor located in the center of the packing element. Typically, a long anchor would be a length in excess of 20 inches. This longer anchor will provide a stronger grip with the surrounding pipe. However, the sealing efficiency is reduced due to the shorter cover lengths on either side of the exposed reinforcing straps.

Another arrangement for the packing element which has been designed offers two long anchors on opposite ends of the packing element, with a short sealing cover in the middle. This arrangement provides an acceptable bi-directional anchor for reinforcing the surrounding pipe. However, this dual anchor design tends to capture fluid between the two anchoring ends as they expand, preventing full expansion of the intermediate sealing cover. The short cover is sometimes an ineffective seal as it allows fluid to bypass between the reinforcing straps and the underside of the cover. In addition, strap buckling can occur within the reinforcing straps as they expand, causing a catastrophic failure of the bridge plug.

To overcome this problem, packing elements have been offered utilizing only a single anchor portion and a single sealing cover portion. In one known arrangement, a short anchor is placed at one end of the packing element, and a longer sealing cover is maintained at the opposite end of the packing element. However, a short anchor biased to one end of the packing element will not grip the surrounding pipe sufficiently to prevent sliding of the bridge plug at the maximum designed differential pressure unless higher initial inflation pressures are used. Further, a short anchor is less effective in low expansion applications.

As can be seen, an improved packing element for an inflatable bridge plug is needed. More specifically, a packing element is needed which employs a longer anchoring portion which is biased at one end of the bladder. Further, a need exists

for an inflatable packing element which maximizes both the anchoring and sealing functions of an inflatable bridge plug.

### **SUMMARY OF THE INVENTION**

The present invention provides an inflatable packing element for use on a bridge plug. In the packing element of the present invention, an expandable anchoring portion is placed at one end of the packing element, while a pliable, expandable sealing cover portion is placed at the opposite end of the packing element. The length of the anchor portion is longer than in known inflatable bridge plugs wherein the anchor is biased to one end. The increased anchor length serves to insure that the inflatable bridge plug will not slide after being set within casing at low expansion ratios, as well as at higher expansion ratios (up to and in excess of 3:1).

The length of the anchor is determined by a novel calculation which considers the coefficient of friction between the reinforcing straps of the anchoring portion and the surrounding pipe wall. The calculation also considers the area of pipe contact as well as contact pressure generated from the bladder of the bridge plug. The length of the anchor portion upon expansion is at least approximately 2.63 x the inner diameter of the opening of the wellbore, e.g., surrounding casing. At the same time, the length of the anchor portion is no greater upon expansion than approximately 49% of the total length of the expanded packing element, that is, the length of the anchor portion engaging the surrounding wellbore opening plus the length of the sealing cover portion engaging the surrounding wellbore opening.

It is desired, though not required, that a pliable cover ring be placed around the welded metal straps of the anchor portion at one end, and the sealing cover portion be circumferentially disposed around the anchor portion at an opposite end.

### **BRIEF DESCRIPTION OF THE DRAWINGS**

So that the manner in which the above recited features of the present invention are attained and can be understood in detail, a more particular description of the invention, briefly summarized above, may be had by reference to the appended drawings. It is to be noted, however, that the appended drawings illustrate only

certain embodiments of this invention and are therefore not to be considered limiting of its scope, for the invention may admit to other equally effective embodiments.

Figure 1 presents a partial cross-sectional view of a bridge plug. The bridge plug is disposed within a portion of a cased wellbore. The bridge plug includes an inflatable packing element of the present invention. The inflatable packing element is seen in side view in an uninflated state.

Figure 2 presents a cross-sectional view of the bridge plug of Figure 1. Here, the inflatable packing element is seen in cross-section. The packing element is again uninflated.

Figure 3 is an enlarged view of an upper portion of the bridge plug of Figures 1 and 2. In this view, the path of fluid for actuating the bridge plug is more clearly seen, with arrows depicting the fluid path.

Figure 4 presents a cross-sectional view of an enlarged portion of the packing element of Figure 1. In this view, the anchor portion and sealing cover portion of the packing element are more clearly seen. The packing element has been inflated.

Figure 5 presents a cross-sectional view of the bridge plug of Figure 1. In this view, the bridge plug is being actuated so as to expand the packing element into frictional and sealing engagement with the surrounding pipe wall. It can be seen that both the anchor portion and the sealing portion of the packing element are in contact with the surrounding tubular.

#### **DETAILED DESCRIPTION OF THE PREFERRED EMBODIMENT**

**Figure 1** presents a partial cross-sectional view of a bridge plug **100**. The bridge plug **100** includes an inflatable packing element **200** of the present invention, in one embodiment. The inflatable sealing element **200** is seen in side view. In the view of **Figure 1**, the sealing element **200** has not yet been inflated.

**Figure 2** presents a cross-sectional view of the bridge plug **100** of **Figure 1**. Here, the same inflatable packing element **200** is seen in cross-section. The packing element **200** is again in its uninflated state.

The bridge plug **100** of **Figures 1** and **2** has been run into a wellbore **10**. It can be seen that the wellbore **10** has been cased with a string of casing **15**. The casing **15** has been set within the surrounding formation **20** of the wellbore **10**. Cured cement **25** is seen in the annular region between the casing **15** and the surrounding earth formation **20**.

The bridge plug **100** of **Figures 1** and **2** has been run into the wellbore **10** on a working string (not shown). The working string may be any type of run-in string, including but not limited to wireline, slickline, fiberoptic cable, drill pipe or coiled tubing. It is understood that a releasing tool or releasing mechanism (not shown) is typically employed in order to release the bridge plug **100** from the working string after the bridge plug **100** has been set within the wellbore **10**.

The bridge plug **100** of **Figures 1** and **2** includes various parts used for setting the packing element **200** within the surrounding pipe **15**. An actuating system is provided in the upper portion of the tool **100** that acts in response to hydraulic pressure. First, an actuation mandrel **110** is disposed centrally within an upper portion of the bridge plug **100**. The actuation mandrel **110** defines a tubular body having a bore **115** therein. The mandrel **110** receives fluid used for actuating the packing element **200**. Coaxially disposed around the central bore **115** of the plug **100** is a valve **120**. The valve **120** selectively permits fluid communication between the central bore **115** of the bridge plug **100** and the packing element **200** below. Initially, the valve **120** is held in a closed position by a shearable connection **122**. An additional spring member **124** serves to bias the valve **120** in its closed position. In **Figures 1** and **2**, the valve **120** is shown in the closed position, with the shearable connection **122** intact.

The valve **120** is designed to open in response to a predetermined pressure that is sufficient to overcome the shearable connection **122** and the biasing force of the spring **124**. The predetermined pressure is applied to a column of fluid within the above running string (not shown). Pressurized fluid acts upon an upper surface **123** of the annularly shaped valve **120** until the shearable connection **122** holding the valve **120** in the open position fails. Thereafter, the fluid pressure moves the valve

**120** downward against spring member **124**. This opens a path for fluid under pressure to travel into an upper annular region **125** of the tool **100**.

**Figure 3** presents an enlarged view of an upper portion of the bridge plug **100** of **Figures 1** and **2**. In **Figure 3**, the resistive forces of the spring **124** have been overcome and the shearable connection **122** holding the valve **120** in the open position has sheared. This allows fluid to flow through a port **112** (shown in **FIG. 3**) in the actuation mandrel **110** and around the valve **120**. Fluid then flows into the upper annular region **125**. Arrows are provided to illustrate the path of fluid from the central bore **115** of the actuation mandrel **110** to the upper annular region **125** of the tool **100**.

Returning to **Figure 2**, below the actuation mandrel **110** is an inner bridge plug mandrel **210**. The bridge plug mandrel **210** defines a tubular body which runs the length of the packing element **200**. A bore **215** is defined within the bridge plug mandrel **210**. Further, an annular region **220** is defined by the space between the outer wall of the bridge plug mandrel **210** and a surrounding packing element **200**. The annular region **220** of the packing element **200** receives fluid from the upper annular region **125** of the bridge plug **100** when the packing element **200** is actuated. This serves as the mechanism for expanding the packing element **200** into a set position within the casing **15**, as will be described below.

**Figure 4** presents an enlarged cross-sectional view of a packing element **200** of the present invention. In this view, the packing element has been expanded into contact with a surrounding string of casing **15**. To accomplish this, fluid has been injected through the valve **120** (shown in **FIG. 3**), through the upper annular region **125**, and into the annulus **220** of the packing element **200**. Fluid continues to flow downward through the tool **100** until it is blocked at a lower end by a plug member **135** (seen in **FIG. 2**). The plug member **135** is held in a first plugged position within the interior of the bridge plug **100** by a separate shearable connection **137**. In this way, sufficient fluid pressure is allowed to build up in order to expand the packing element **200**.

The plug member **135** (seen in **FIGS. 1** and **2**) is capable of being moved to a second open position in response to a higher fluid pressure. This allows the setting

fluid to flow through the annulus **220** and to release pressure within the packing element **200**. In the view of **Figures 1** and **2**, the plug **135** is shown in the first position before the shearable connection **137** has failed. Likewise, in the view of **Figures 4** and **5**, the plug **135** has not yet moved downward to permit fluid to flow out of the lower end of the bridge plug **100**. The packing element **200** is thus held in its inflated state.

The parts of the packing element **200** of the present invention are best seen in the cross-sectional view of **Figure 4**. First, an elongated bladder **230** is seen. The bladder **230** is disposed circumferentially around the inner mandrel **210** of the bridge plug **100**. The bladder **230** is fabricated from an elastomeric or other pliable material. The bladder **230** is connected at opposite ends to end connectors **232** and **234**. In the arrangement shown in **FIG. 4**, the upper end connector **232** is fixed ring, meaning that the upper end of the packing element **200** is stationary with respect to the inflatable tool **200**. However, the lower end connector **234** is connected to a slidable sub **237**. The slidable sub **237**, in turn, is movable along the bridge plug mandrel **210**. This permits the bladder **230** and other packing element **200** parts to freely expand outwardly in response to the injection of fluid into the annular region **220** between the bridge plug mandrel **210** and the bladder **230**. In this view, the lower end connector **234** has moved upward along the bridge plug mandrel **210**, thereby allowing the packing element **200** to be inflated.

Also visible in **Figure 4** is an anchor portion **240** of the packing element **200**. The anchor portion **240** in one aspect is fabricated from a series of reinforcing straps **241** (not shown individually) that are radially disposed around the bladder **230**. The straps **241** are aligned along the linear plane of the tool **100** so as to essentially run the length of the packing element **200**. At the same time, the straps **241** are placed radially around the bladder **230** in a tightly overlapping fashion. Preferably, the straps **241** are fabricated from a metal alloy. However, other materials suitable for engaging a surrounding steel pipe **15** (or earth formation) may be used, such as ceramic or other hardened composite. It is understood that the present invention is not limited to the method of fabrication used for the anchor portion **240**. Indeed, a plurality of ceramic ribs or other materials may be employed as well. The straps **241**

are arranged to substantially overlap one another in a radial array. A sufficient number of straps **241** are used for the anchor portion **240** to retain the bladder **230** therein as the anchor portion **240** expands.

The metal straps **241** are fixedly connected at opposite first and second ends. In one aspect, the strap ends are connected by welding. The ends of the straps **241** are welded (or otherwise connected) to the upper **232** and lower **234** end connectors, respectively.

The anchor portion **240** is not defined by the entire length of the straps **241**; rather, the anchor portion **240** represents only that portion of the straps **241** intermediate the end connectors **232**, **234** that is exposed, and can directly engage a surrounding wellbore opening, e.g., casing **15**. In this respect, in the preferred embodiment, a length of the straps **241** is covered by a sealing cover portion **250**.

The packing element **200** of **Figure 4** shows the sealing cover portion **250**. The sealing cover portion **250** is shown in cross-section in **Figure 4**; it is shown in side view in **Figure 1**. The sealing cover portion **250** defines a pliable cover placed over the bladder **230**. In the preferred arrangement, the cover portion **250** is also placed over a selected length of the metal straps **241** at one end. Where a cover ring **235** is employed, the sealing cover portion **250** is placed over the straps **241** (or other anchoring material) at the end opposite the cover ring **235**. The sealing cover portion **250** provides a fluid seal when the packing element **200** is expanded into contact with the surrounding inner diameter of the pipe **15**.

The sealing cover **250** is fabricated from a material suitable for the service environment in which the bridge plug **100** is to be operated. Factors to be considered when selecting a sealing cover material include the chemicals likely to contact the cover **250**, the prolonged impact of hydrocarbon contact on the cover **250**, the presence and concentration of corrosive compounds such as hydrogen sulfide or chlorine within the wellbore **10**, and the pressure and temperature at which the cover **250** must operate. In a preferred embodiment, the cover **250** is fabricated from an elastomeric material. However, non-elastomeric materials or polymers may be employed as well, so long as they substantially prevent production fluids from

passing upwardly between the outer surface of the inflated bridge plug **100** and the inner surface of the surrounding string of pipe, e.g. casing **15**, or the formation.

In one arrangement, the pliable cover **250** is fabricated from a unique composition suitable for expanding in response to an inflated bladder. The composition comprises a specially blended nitrile base compound designed to maintain compound properties at elevated temperatures. Again, however, pliable materials that do not include a nitrile base may be employed, such as a fluoro-elastomer.

The pliable sealing cover **250** used in the typical bridge plug **100** is substantially uniform in thickness. The sealing cover **250** for the packing element **200** of the present invention may also be uniform in thickness, both radially and axially. However, in one unique arrangement for the packing element **200** of the present invention, the sealing cover **250** employs a non-uniform thickness. In one aspect, the thickness of the sealing cover **250** is tapered so as to gradually increase in thickness as the cover **250** approaches the anchor portion **240**. In one aspect, the taper is cut along a constant angle, such as 3 degrees. In another aspect, the thickness of the cover **250** is variable in accordance with the undulating design of *Carisella*, discussed in U.S. Patent 6,223,820, issued May 1, 2001. The variable thickness cover reduces the likelihood of folding within the bladder **230** during expansion. This is because the variable thickness allows some sections of the cover element **250** to expand faster than other sections, causing the overall exterior of the element **200** to expand in unison.

**Figure 5** demonstrates the bridge plug **100** of **Figures 1** and **2**, in its actuated state. This means that the anchor portion **240** and sealing cover portion **250** of the packing element **200** have been expanded into frictional and sealing engagement, respectively, with the surrounding casing **15** (or borehole). As the bladder **230** is expanded, the exposed portion of straps **241** that define the anchor portion **240** frictionally engages the surrounding pipe **15** in order to set the bridge plug **100**. Likewise, expansion of the bladder **230** also expands the sealing cover portion **250**

into engagement with the surrounding bore. The bridge plug **100** is thus both frictionally and sealingly set within the wellbore **10**.

It should be noted at this point that the packing element **200** as shown in **FIGS. 1, 2, 4** and **5** may be used as the inflatable element for any inflatable bridge plug **100** or packer. In this respect, those of ordinary skill in the art will appreciate that there are numerous ways for actuating an inflatable element. The present invention is not limited to any particular means or apparatus for actuating the packing element **200**, or to any particular type of inflatable bridge plug or packer, but is directed to the packing element **200** itself. Thus, the bridge plug **100** shown in **FIGS. 1-5** is merely exemplary for purposes of disclosure to one of ordinary skill in the art.

A cover ring **235** is optionally disposed at one end of the anchor portion **240**. The cover ring **235** defines a short elastomeric tubular member which serves to retain the welded metal straps **241** at one end of the anchor portion **240**. The cover ring **235** typically does not serve a sealing function with the surrounding pipe **15** or other wellbore opening. This is particularly true when the bridge plug **100** is inflated in a "maximum i.d." hole for the design of the tool **100**. In that instance, a very small portion of the cover ring **235**, if any, even engages the surrounding borehole. The length of the cover ring is preferably less than the outer diameter of the inflation element's **200** running diameter.

In the arrangement for packing element **200** of **FIG. 4**, the cover ring **235** is seen proximate to the upper end connector **232**. However, it is understood that the cover ring **235** may be disposed at either end of the anchor portion **240** so long as it is opposite the sealing cover portion **250**.

The inflatable element **200** of the present invention presents a novel relative configuration for the anchor portion **240** and the sealing cover portion **250**. First, the anchor portion **240** is biased to one end of the packing element **200**. Thus, the anchor portion **240** is disposed at one end of the packing element **200**, while the sealing cover portion **250** is disposed at the other end of the packing element **200**. It is, of course, understood that the packing element **200** may include a cover ring **235** at the end of the packing element **200** opposite the sealing cover portion **250**.

WEAT/0205-PCT

However, the cover ring **235** is not substantially inflated, and serves neither an anchoring function nor a sealing function, but primarily exists to help bind the welded straps **241** together opposite the sealing cover portion **250**.

The sealing cover **250** is disposed circumferentially around a section of the reinforcing straps **241** opposite the cover ring **235**. Preferably, the cover **250** is bonded to the adjacent straps on the inner surface of the cover **250**. This means that the reinforcing straps **241** (or other anchoring material) are covered at one end and do not engage the surrounding wellbore opening. However, the straps are exposed at the end opposite the cover **250** to define the anchor portion **240**.

The anchor portion **240** has a defined minimum and maximum length. For purposes of the present invention, the anchor portion **240** is defined as the expanded length of straps **241** (or other anchoring material) that is not covered by the sealing cover **250** and engages the surrounding casing or borehole upon expansion. In the event some portion of the cover ring **235** also engages the surrounding borehole upon inflation of the bladder **230**, then that incidental portion of the cover ring **235** is included in the definition of the expanded anchor portion **240**.

The minimum length of the anchor portion **240** is defined by a mathematical formula. The anchor length **240** is based upon the formula of  $2.63 \times$  the inside diameter of the surrounding pipe **15** (or formation) in which the inflatable packer **100** is to be set. By way of example, a calculation can be made for the minimum overall length of the anchor portion **240** of a packing element **200** for a 2 1/8" bridge plug. A 2-1/8" inflation element can be set in 7 inch casing. The inner diameter for a typical 7 inch casing is 6 3/8". Thus, the approximate minimum anchor length **240** for the 2-1/8" inflatable element upon expansion would be:

$$2.63 \times 6.375 = 16.766 \text{ inches.}$$

This means that in this example, at least 16.766 inches of anchoring material/cover ring must engage the surrounding wellbore opening upon expansion. Packing elements which are larger than 2 1/8" in running diameter may be set in larger wellbores and will have anchor portions longer than 16.77".

WEAT/0205-PCT

As for the maximum length, the maximum length of the expanded anchor portion **240** does not encompass more than approximately 49% of the overall length of the packing element **200** upon expansion. In this regard, the anchor portion **240** does not extend beyond the center of the packing element **200** after the packing element is expanded. For purposes of this disclosure, the length of the expanded packing element **200** is generally defined as the length of the sealing cover portion **250** engaging the surrounding wellbore opening, plus the length of the anchor portion **240** (including any part of the cover ring **235**) that engages the surrounding wellbore opening.

It is again noted that the ends of the internal ribs or straps **241** are connected to end connectors **232, 234**. These end portions do not expand and are not included in the calculation for the length of the packing element **200** for purposes of this invention. For example, in one arrangement for the inflatable element **200** of the present invention, the length of the straps **241** from weld-to-weld is 56 inches. However, the length of the straps urging the packing element **200** to engage the surrounding wellbore is only 44.5 inches. The sealing cover portion **250** covers a length of these 44.5 inches of expanded straps at one end. According to the present invention, the anchor portion **240**, i.e., exposed portion of straps **241** engaging the surrounding wellbore upon expansion, can be no longer than approximately 21.8 inches. Where the tool **100** is set in 7 inch casing (6.375-inch inner diameter), the anchor portion **240** must provide at least 16.77 inches of anchoring material engaging the surrounding wellbore opening.

The inflatable sealing element **200** of the present invention has utility in either cased hole or open hole completions. It may also be utilized within tubing, perforated casing or slotted liner.

**Claims:**

1. An inflatable packing element for sealing an opening within a wellbore, the opening having an essentially circular cross-section defining an inner diameter, the packing element comprising:
  - an expandable anchor portion;
  - an expandable sealing cover portion;
  - wherein the length of the anchor portion upon expansion is at least approximately 2.63 x the inner diameter of the opening of the wellbore; and
  - wherein the anchor portion is no greater in length upon expansion than approximately 49% of the total length defined by the length of the anchor portion engaging the surrounding wellbore opening plus the length of the sealing cover portion engaging the surrounding wellbore opening.
  
2. The inflatable packing element of claim 1, wherein:
  - the inflatable anchor portion is fabricated from a plurality of overlaid reinforcing straps arranged in a radial array; and
  - the inflatable sealing cover portion is fabricated from a pliable material.
  
3. The inflatable packing element of claim 2, wherein:
  - the plurality of reinforcing straps of the anchor portion have a first end and second end;
  - the inflatable sealing cover portion is disposed around the plurality of the reinforcing straps proximate to the second end of the reinforcing straps, but leaving the reinforcing straps exposed proximate to the first end of the reinforcing straps; and
  - the exposed section of reinforcing straps defining the anchor portion.
  
4. The inflatable packing element of claim 3, wherein the reinforcing straps are fabricated from a metal alloy.
  
5. The inflatable packing element of claim 4, wherein the reinforcing straps are fabricated from a ceramic material.

6. The inflatable packing element of claim 5, wherein the reinforcing straps are fabricated from a composite material.
7. The inflatable packing element of claim 1, wherein the inflatable cover portion has a variable cover thickness to allow some section of the inflatable sealing cover portion to expand faster than other sections, thereby causing the inflatable sealing element to expand in unison.
8. The inflatable packing element of claim 7, wherein the inflatable cover portion is fabricated from an elastomeric material.
9. The inflatable packing element of claim 1, further comprising an elongated inflatable bladder, the bladder residing essentially concentrically within the anchor portion and the sealing cover portion of the packing element so as to urge the anchor portion and the sealing cover portion outwardly upon inflation of the bladder.
10. The inflatable packing element of claim 1, wherein the opening within the wellbore is defined by a string of casing.
11. The inflatable packing element of claim 1, wherein the opening within the wellbore is defined by the formation.
12. The inflatable packing element of claim 1, wherein the opening within the wellbore is defined by a string of production tubing.
13. An inflatable packing element for sealing a pipe within a wellbore, the pipe having an essentially circular profile defining an inner diameter, the packing element comprising:
  - an elongated inflatable bladder having a first end and a second end;
  - a plurality of overlaying metal straps disposed in a radial array, the metal straps having first ends proximate to the first end of the bladder, and second ends proximate to the second end of the bladder, and the plurality of metal straps being disposed circumferentially around the bladder and being outwardly expandable upon inflation of the bladder;

a cover ring disposed circumferentially around the plurality of metal straps proximate to the respective first ends of the metal straps;

an inflatable sealing cover portion disposed radially around the plurality of metal straps proximate to the respective second ends of the metal straps, and leaving a section of the plurality of metal straps exposed between the cover ring and the sealing cover portion so as to define an anchor portion;

wherein the anchor portion has a minimum length upon expansion defined by  $2.63 \times$  the inner diameter of the pipe; and

wherein the anchor portion has a maximum length defined by no more than approximately 49% of (1) the length of the expanded sealing cover portion engaging the surrounding pipe, plus (2) the length of the expanded anchor portion engaging the surrounding pipe, plus (3) the length of the cover ring engaging the surrounding pipe, if any, upon full expansion of the bladder.

14. The packing element of claim 13, wherein the surrounding pipe is a string of casing.

15. The packing element of claim 13, wherein the inflatable sealing cover portion is fabricated from a pliable elastomeric material.

16. The packing element of claim 15, wherein the thickness of the expandable sealing cover portion is non-uniform.

17. The packing element of claim 15, wherein the thickness of the expandable sealing cover portion is tapered to increase as the sealing cover portion approaches the anchor portion.

18. The packing element of claim 15, wherein the thickness of the pliable sealing cover portion varies along the length of the cover portion to allow some sections of the covered portion to expand faster than other sections, thereby causing the exterior of the sealing element to expand essentially in unison.

19. The packing element of claim 13, wherein the expandable bladder is molded.

20. An inflatable packing element for sealing an opening within a wellbore, the opening having an essentially circular cross-section defining an inner diameter, the packing element comprising:

an inflatable anchor portion;

an inflatable sealing cover portion;

wherein the length of the anchor portion engaging the inner diameter upon expansion is at least approximately 2.63 x the inner diameter of the opening of the wellbore; and

wherein the anchor portion engaging the inner diameter is no greater in length upon expansion than approximately 49% of the total length defined by the length of the anchor portion engaging the surrounding wellbore opening plus the length of the sealing cover portion engaging the surrounding wellbore opening.

21. The inflatable packing element of claim 20, wherein:

the inflatable anchor portion is fabricated from a plurality of overlaid reinforcing straps arranged in a radial array; and

the inflatable sealing cover portion is fabricated from a pliable material.

22. The inflatable packing element of claim 21, wherein:

the plurality of reinforcing straps of the anchor portion have a first end and second end;

the inflatable sealing cover portion is disposed around the plurality of the reinforcing straps proximate to the second end of the reinforcing straps, but leaving the reinforcing straps exposed proximate to the first end of the reinforcing straps; and

the exposed section of reinforcing straps defining the anchor portion.

23. The inflatable packing element of claim 22, wherein the reinforcing straps are fabricated from a metal alloy.

24. The inflatable packing element of claim 23, wherein the reinforcing straps are fabricated from a ceramic material.

25. The inflatable packing element of claim 24, wherein the reinforcing straps are fabricated from a composite material.

26. The inflatable packing element of claim 20, wherein the inflatable sealing\_cover portion has a variable thickness to allow some sections of the inflatable sealing cover portion to expand faster than other sections, thereby causing the inflatable sealing cover portion to expand in unison.

27. The inflatable packing element of claim 26, wherein the inflatable sealing cover portion is fabricated from an elastomeric material.

28. The inflatable packing element of claim 20, further comprising an elongated inflatable bladder, the bladder residing essentially concentrically within the anchor portion and the sealing cover portion of the packing element so as to urge the anchor portion and the sealing cover portion outwardly upon inflation of the bladder.

29. The inflatable packing element of claim 20, wherein the opening within the wellbore is defined by a string of casing.

30. The inflatable packing element of claim 20, wherein the opening within the wellbore is defined by the formation.

31. The inflatable packing element of claim 20, wherein the opening within the wellbore is defined by a string of production tubing.

32. An inflatable packing element for sealing a pipe within a wellbore, the pipe having an essentially circular profile defining an inner diameter, the packing element comprising:

an elongated inflatable bladder having a first end and a second end;

a plurality of overlaying metal straps disposed in a radial array, the metal straps having first ends proximate to the first end of the bladder, and second ends proximate to the second end of the bladder, and the plurality of metal straps being disposed circumferentially around the bladder and being outwardly expandable upon inflation of the bladder;

a cover ring disposed circumferentially around the plurality of metal straps proximate to the respective first ends of the metal straps;

an inflatable sealing cover portion disposed radially around the plurality of metal straps proximate to the respective second ends of the metal straps, and leaving a section of the plurality of metal straps exposed between the cover ring and the sealing cover portion so as to define an anchor portion;

wherein the anchor portion has a minimum length upon expansion defined by  $2.63 \times$  the inner diameter of the pipe; and

wherein the anchor portion has a maximum length defined by no more than approximately 49% of (1) the length of the inflated sealing cover portion engaging the surrounding pipe, plus (2) the length of the inflated anchor portion engaging the surrounding pipe, plus (3) the length of the cover ring engaging the surrounding pipe, if any, upon full expansion of the bladder.

33. The inflatable packing element of claim 32, wherein the surrounding pipe is a string of casing.

34. The inflatable packing element of claim 32, wherein the inflatable sealing cover portion is fabricated from a pliable elastomeric material.

35. The inflatable packing element of claim 34, wherein the thickness of the inflatable sealing cover portion is non-uniform.

36. The inflatable packing element of claim 34, wherein the thickness of the inflatable sealing cover portion is tapered to increase as the sealing cover portion approaches the anchor portion.

37. The inflatable packing element of claim 34, wherein the thickness of the sealing cover portion varies along the length of the sealing cover portion to allow some sections of the sealing covered portion to expand faster than other sections, thereby causing the exterior of the sealing cover portion to expand essentially in unison.

38. The inflatable packing element of claim 32, wherein the inflatable bladder is molded.

1/5

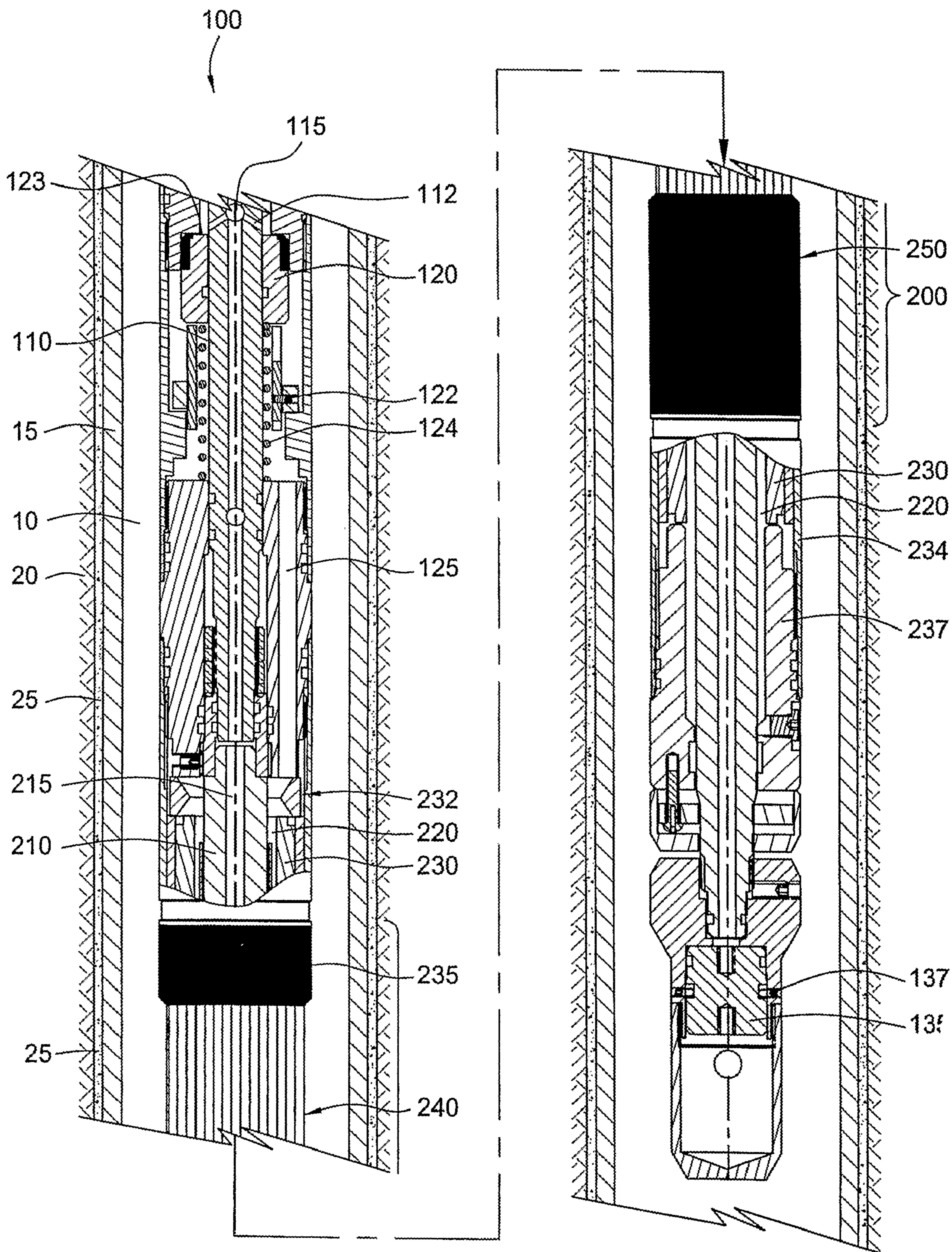

FIG. 1

2/5

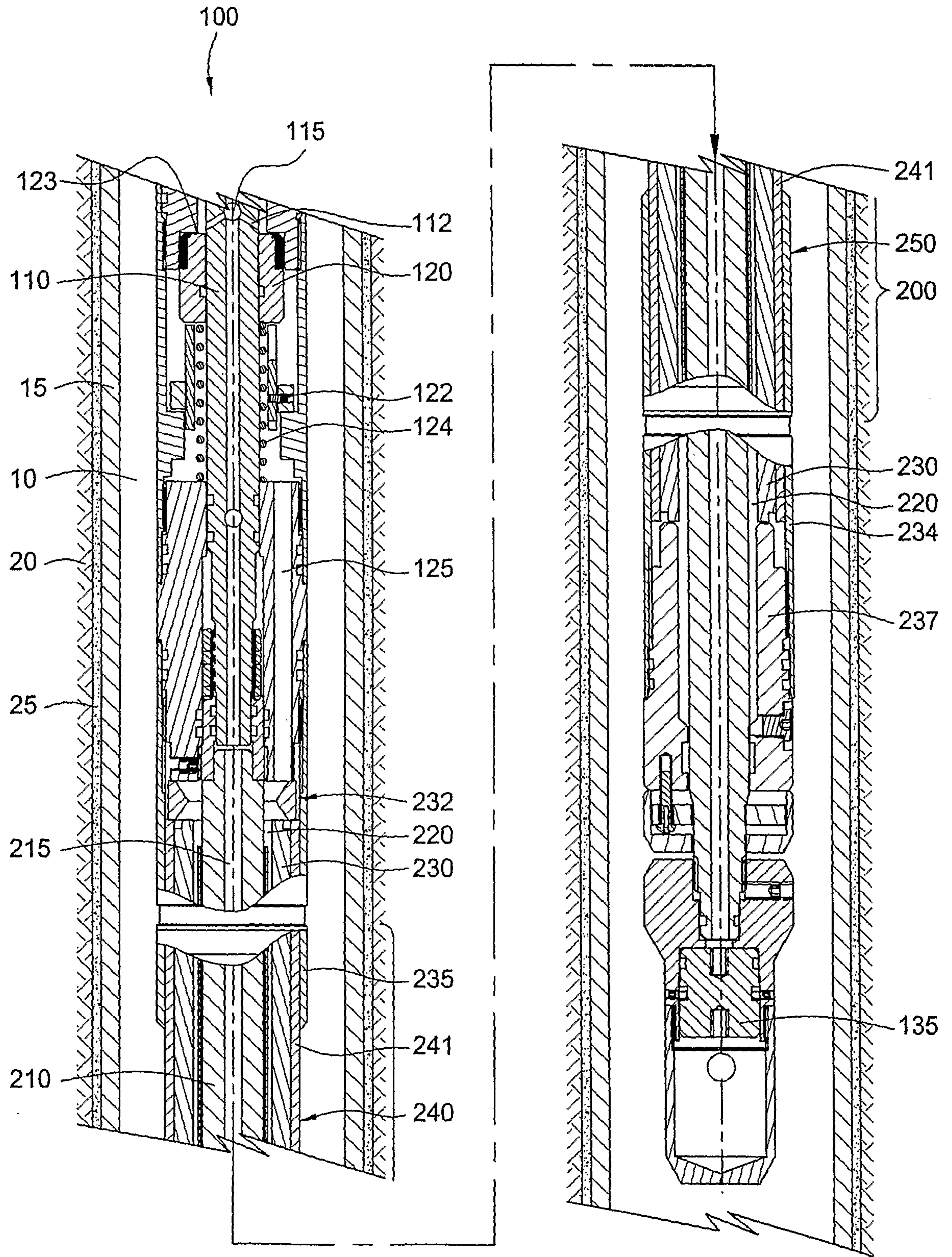

FIG. 2

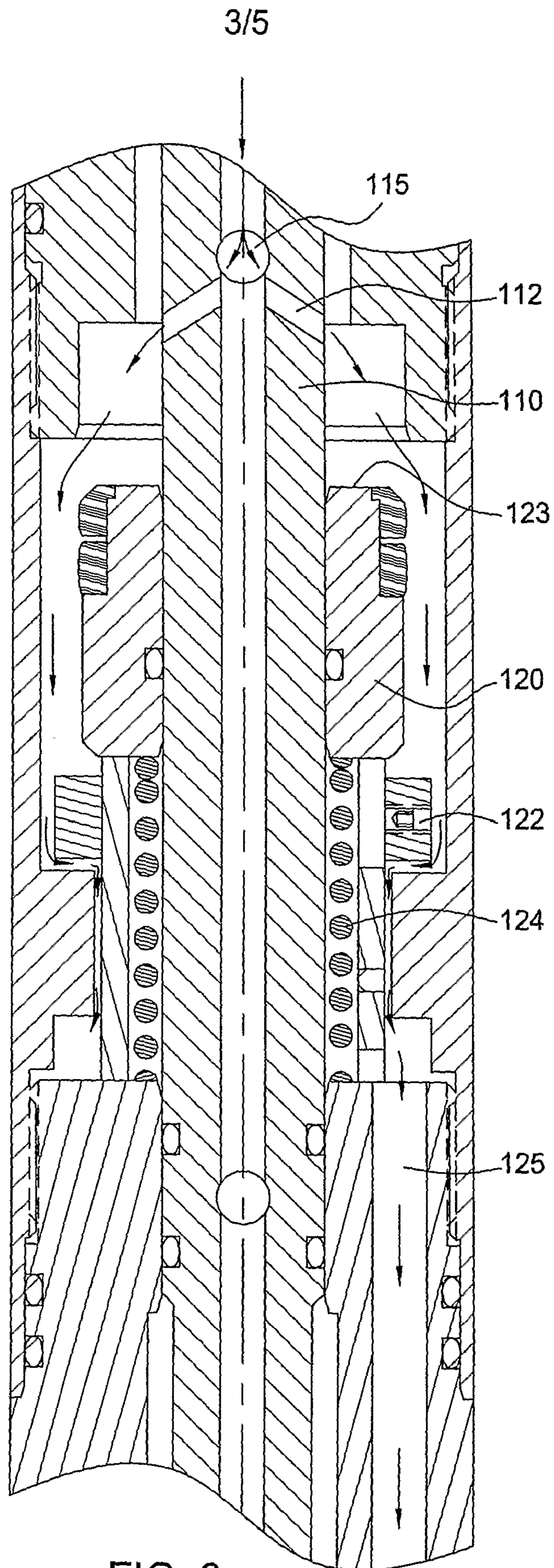

FIG. 3

4/5

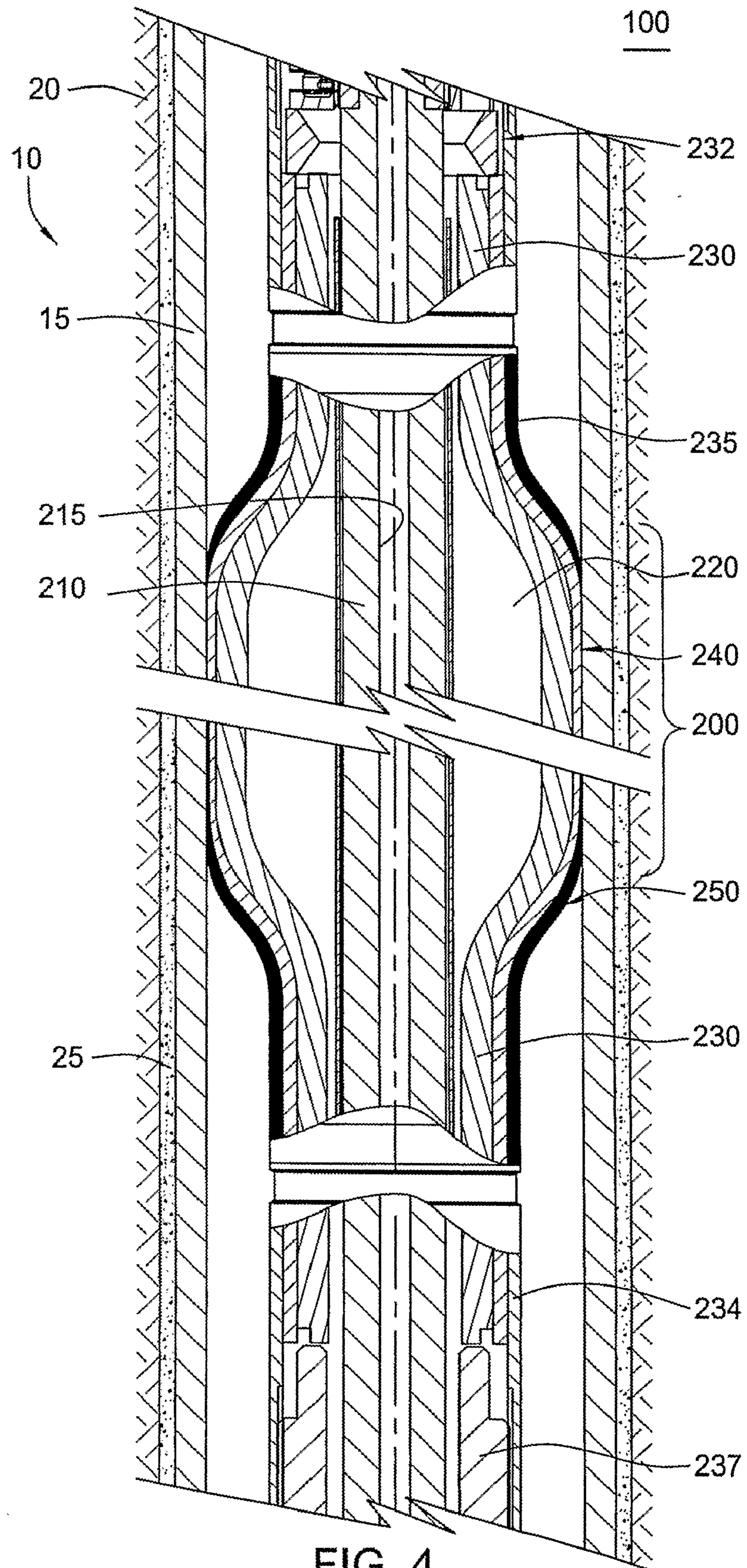

FIG. 4

5/5

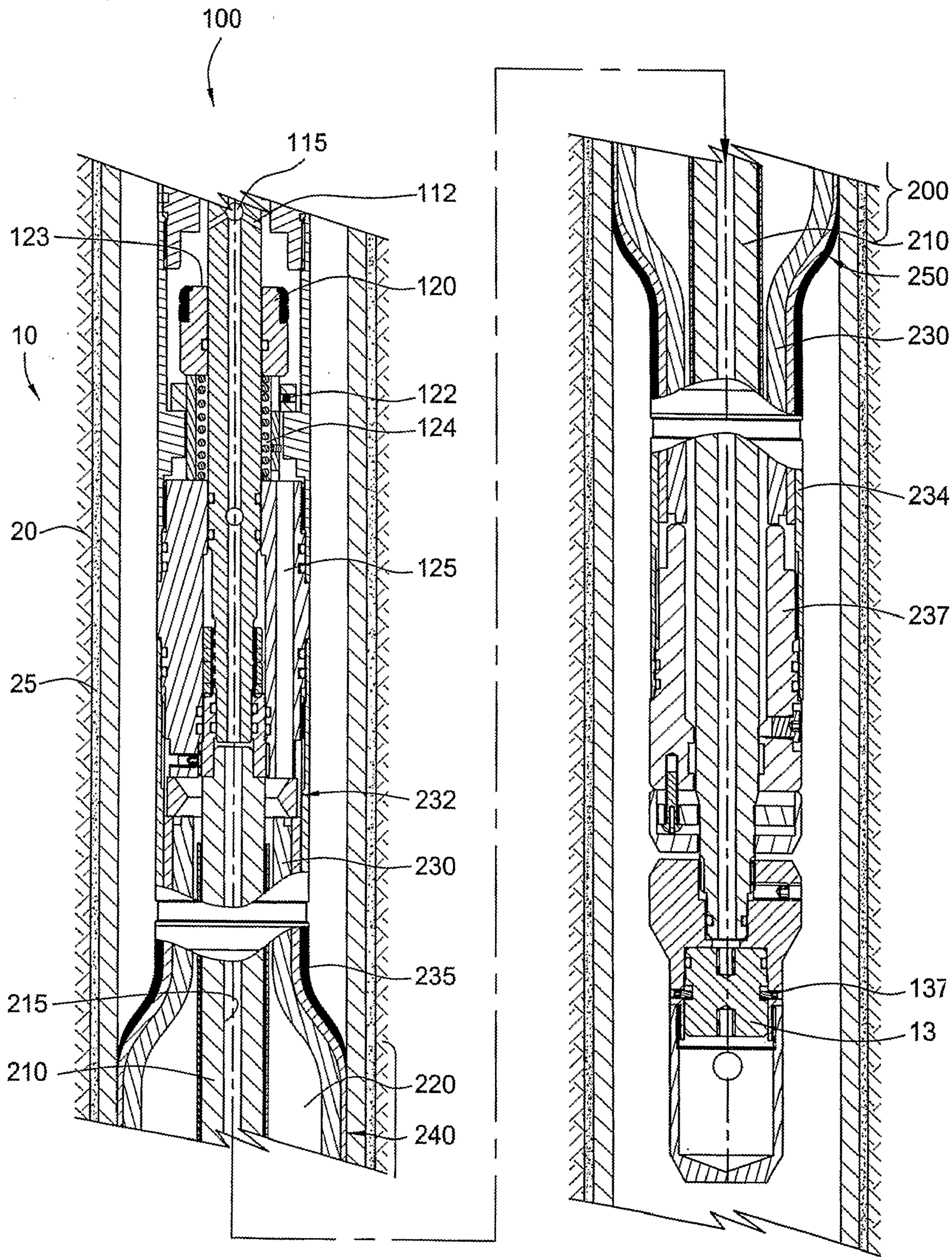

FIG. 5

