



(51) International Patent Classification:

A61B 19/00 (2006.01) A61B 17/88 (2006.01)  
A61B 17/70 (2006.01) A61B 5/06 (2006.01)

(21) International Application Number:

PCT/CA2013/050512

(22) International Filing Date:

3 July 2013 (03.07.2013)

(25) Filing Language:

English

(26) Publication Language:

English

(30) Priority Data:

61/667,714 3 July 2012 (03.07.2012) US

(71) Applicant: **7D SURGICAL INC.** [CA/CA]; 350 Victoria Street, Toronto, Ontario M5B 2K3 (CA).

(72) Inventors: **YANG, Victor X.D.**; 350 Victoria Street, Toronto, Ontario M5B 2K3 (CA). **SIEGLER, Peter**; 1507-25 Broadway Avenue, Toronto, Ontario M4P 1T7 (CA). **MARIAMPILLAI, Adrian**; 381 Front Street West, Suite 1210, Toronto, Ontario M5V 3R8 (CA). **STANDISH, Beau Anthony**; 267 Glebe Avenue, Toronto, Ontario M4C 3T7 (CA). **LEUNG, Michael**; 178 Adrian Crescent, Markham, Ontario L3P 6Z6 (CA).

(74) Agent: **HILL & SCHUMACHER**; 264 Avenue Road, Toronto, Ontario M4V 2G7 (CA).

(81) Designated States (unless otherwise indicated, for every kind of national protection available): AE, AG, AL, AM, AO, AT, AU, AZ, BA, BB, BG, BH, BN, BR, BW, BY, BZ, CA, CH, CL, CN, CO, CR, CU, CZ, DE, DK, DM, DO, DZ, EC, EE, EG, ES, FI, GB, GD, GE, GH, GM, GT, HN, HR, HU, ID, IL, IN, IS, JP, KE, KG, KN, KP, KR, KZ, LA, LC, LK, LR, LS, LT, LU, LY, MA, MD, ME, MG, MK, MN, MW, MX, MY, MZ, NA, NG, NI, NO, NZ, OM, PA, PE, PG, PH, PL, PT, QA, RO, RS, RU, RW, SC, SD, SE, SG, SK, SL, SM, ST, SV, SY, TH, TJ, TM, TN, TR, TT, TZ, UA, UG, US, UZ, VC, VN, ZA, ZM, ZW.

(84) Designated States (unless otherwise indicated, for every kind of regional protection available): ARIPO (BW, GH, GM, KE, LR, LS, MW, MZ, NA, RW, SD, SL, SZ, TZ, UG, ZM, ZW), Eurasian (AM, AZ, BY, KG, KZ, RU, TJ, TM), European (AL, AT, BE, BG, CH, CY, CZ, DE, DK, EE, ES, FI, FR, GB, GR, HR, HU, IE, IS, IT, LT, LU, LV, MC, MK, MT, NL, NO, PL, PT, RO, RS, SE, SI, SK, SM, TR), OAPI (BF, BJ, CF, CG, CI, CM, GA, GN, GQ, GW, KM, ML, MR, NE, SN, TD, TG).

Published:

- with international search report (Art. 21(3))
- before the expiration of the time limit for amending the claims and to be republished in the event of receipt of amendments (Rule 48.2(h))

(54) Title: ATTACHMENTS FOR TRACKING HANDHELD IMPLEMENTS

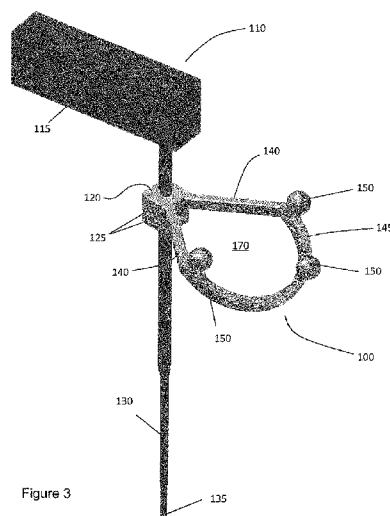

(57) Abstract: Devices and systems are provided for tracking a position and orientation of a handheld implement, such that the handheld implement may be trackable with an overhead tracking system. A support member secures one or more markers relative to a longitudinal portion of the handheld implement, and a marker plane containing the markers is orientated an angle relative to a longitudinal axis of the longitudinal portion. A marker assembly may include a support member for supporting the markers, and a connector for removably attaching the marker assembly to one or more handheld implements. The marker assembly may be configured to be removably attachable to a plurality of connection adapters, where each connection adapter is further connectable to a handheld implement, optionally at a calibrated position, such that a single connection adapter can be optionally employed to track a plurality of handheld implements. The handheld implement may be a medical instrument.



## **ATTACHMENTS FOR TRACKING HANDHELD IMPLEMENTS**

### **CROSS-REFERENCE TO RELATED APPLICATION**

This application claims priority to U.S. Provisional Application No. 61/667,714, titled “ATTACHMENTS FOR TRACKING HANDHELD  
5 IMPLEMENTS” and filed on July 3<sup>rd</sup>, 2012, the entire contents of which is incorporated herein by reference.

### **BACKGROUND**

The present disclosure relates to guidance and tracking systems for tracking  
handheld implements, such as medical instruments. More particularly, the present  
10 disclosure relates to active and passive marker arrangements for surgical guidance and tracking of medical instruments.

Surgical guidance enables surgeons to localize the position of surgical  
instruments relative to the human body without having full visual access during  
surgery. Surgical guidance is routinely used in surgeries of the spine, brain, hip or  
15 other organs.

In general, surgical guidance consists of two steps: The first step includes the  
acquisition of a three dimensional (3D) representation of relevant portion of the body.  
This step may involve a single or multiple imaging modalities such as computer  
tomography (CT), magnetic resonance tomography (MRT), positron emission  
20 tomography (PET) and ultrasound (US). The 3D representation may be acquired  
before and/or during the surgical procedure. In the second step, the spatial position of  
the body and the spatial relation of the surgical instruments to the position of the body  
are tracked during the surgery. The spatial position of the body is correlated to its 3D

representation using specific image registration techniques. After registration, the spatial position of the surgical instruments can be displayed with a 3D representation of the body for the surgeon.

Typically, optical-based systems are used for the tracking of the spatial  
5 positions during the surgery. These systems are based on two cameras that detect the positions of at least three markers attached to the tracked surgical instruments (for example, mounted with LEDs as disclosed in US Patent No. 5,921,992, or mounted with reflective probes as disclosed in US Patent No. 6,061,644).

There are many possible designs for the attachment of these markers to  
10 surgical instruments that include a longitudinal shaft (for example, US Patent No. 6,021,343 , US Patent No. 7,226,456 B2 , US Patent No. 6,556,857 B1 , US Patent No. 7,166,114 B2, and US Patent No. 2002/0077540 A1). However, most of these designs include a common characteristic that the cameras of the optical tracking system are oriented to view the side of the shaft of the surgical instruments. The  
15 markers are therefore aligned along the instrument shaft.

In other applications, the tracking system may be oriented directly above the surgical incision, such that the tracking system “looks” into the incision. These applications include arrangements for which the tracking system is integrated into the surgical lighting system (for example, US Patent No. 7,224,472), or arrangements for  
20 which the tracking system is integrated into a system for performing optical topology imaging of anatomy within the incision (for example, US Patents No. 5,531,520 and 5,999,840 and PCT Patent Application PCT/CA2011/050257).

## SUMMARY

Devices and systems are provided for tracking a position and orientation of a handheld implement, such that the handheld implement may be trackable with an overhead tracking system. A support member secures one or more markers relative to  
5 a longitudinal portion of the handheld implement, and a marker plane containing the markers is orientated an angle relative to a longitudinal axis of the longitudinal portion. A marker assembly may include a support member for supporting the markers, and a connector for removably attaching the marker assembly to one or more handheld implements. The marker assembly may be configured to be removably  
10 attachable to a plurality of connection adapters, where each connection adapter is further connectable to a handheld implement, optionally at a calibrated position, such that a single connection adapter can be optionally employed to track a plurality of handheld implements. The handheld implement may be a medical instrument.

Accordingly, in a first aspect, there is a marker assembly for locating a  
15 handheld implement, the marker assembly comprising: a support member; at one or more tracking markers affixed to the support member, the tracking markers defining a marker plane; and a connector configured to removably attach the support member to a longitudinal portion of the handheld implement, the longitudinal portion defining a longitudinal axis; wherein the marker plane is not parallel to the longitudinal axis  
20 when the marker assembly is secured to the handheld implement; and wherein the one or more tracking markers are suitable for locating a three-dimensional position and orientation of the handheld implement when the marker assembly is secured to the handheld implement.

In another aspect, there is provided an interchangeable marker system for  
25 tracking a plurality of handheld implements, the system comprising: a plurality of

connection adapters, wherein each connection adapter is attached to, or attachable to, a longitudinal shaft of one of the handheld implements, and wherein the connection adapters have a common outer cross-section; and a marker assembly comprising: a longitudinal body having an inner bore suitable for receiving one of the connection  
5 adapters; a connection mechanism for connecting the longitudinal body to the connection adapter; a support member connected to the longitudinal body; and one or more tracking markers affixed to the support member, the tracking markers defining a marker plane; wherein the marker assembly is removably attachable to each of the handheld implements through the connection adapters; and wherein the one or more  
10 tracking markers are suitable for locating a three-dimensional position and orientation of the handheld implement when the marker assembly is secured to the handheld implement.

In another aspect, there is provided a guidance system for tracking one or more handheld implements, the guidance system comprising: a marker assembly as  
15 described above; a tracking system configured to detect a signal associated with each tracking marker, wherein the tracking system is positioned in a substantially overhead configuration; and a processor configured to receive the signals and to calculate a relative position and orientation of the handheld implement based on the signals, when the marker assembly is secured to the handheld implement.

20 In another aspect, there is provided a trackable handheld device comprising: a handheld implement comprising a longitudinal shaft, the longitudinal shaft defining a longitudinal axis; a support member connected to the longitudinal shaft; and one or more tracking markers affixed to the support member, the tracking markers defining a marker plane; wherein the marker plane is not parallel to the longitudinal axis, such  
25 that the tracking markers are visible to an overhead tracking system during use of the

handheld implement; and wherein the one or more tracking markers are suitable for locating a three-dimensional position and orientation of the handheld implement by the overhead tracking system.

In another aspect, there is provided a trackable tool system comprising:

- 5 a plurality of exchangeable tool extensions, each exchangeable tool extension having a proximal portion, a distal functional end, and a longitudinal axis; a handheld body adapted to detachably secure each exchangeable tool extension at the proximal portion thereof, such that one exchangeable tool extension may be secured to the handheld body at any given time; a support member connected to the handheld body;
- 10 and one or more tracking markers affixed to the support member, the tracking markers defining a marker plane; wherein each exchangeable tool extension has common length, such that when a first exchangeable tool extension is replaced with a second exchangeable tool extension, the one or more tracking markers are suitable for locating a three-dimensional position of the distal functional end of the second
- 15 exchangeable tool extension and an orientation the second exchangeable tool extension by a tracking system without recalibration.

- In another aspect, there is provided a guidance system for tracking one or more handheld implements, the guidance system comprising: a trackable handheld device as described above; a tracking system configured to detect a signal associated
- 20 with each tracking marker, wherein the tracking system is positioned in a substantially overhead configuration; and a processor configured to receive the signals and to calculate a relative position and orientation of the handheld implement based on the signals, when the support member is secured to the handheld implement.

- In another aspect, there is provided a guidance system for tracking one or
- 25 more handheld implements, the guidance system comprising: an interchangeable

marker system as described above; a tracking system configured to detect a signal associated with each tracking marker, wherein the tracking system is positioned in a substantially overhead configuration; and a processor configured to receive the signals and to calculate a relative position and orientation of the handheld implement based  
5 on the signals, when the marker assembly is secured to the handheld implement.

A further understanding of the functional and advantageous aspects of the disclosure can be realized by reference to the following detailed description and drawings.

### BRIEF DESCRIPTION OF DRAWINGS

10 Embodiments will now be described, by way of example only, with reference to the drawings, in which:

**Figure 1** shows (a) a schematic of an example surgical guidance system that includes an overhead integrated tracking system that employs structured light surface detection for image registration and optical tracking of medical instruments and  
15 medical devices with marker attachments, (b) a conventional marker arrangement on a medical instrument for optical tracking from the side direction, and (c) an illustration of the line of sight obstruction problem that would occur with such an arrangement when employed with overhead tracking.

**Figure 2** provides (a) an example surgical guidance system that includes an  
20 overhead integrated tracking system employing structured light surface detection for image registration and optical tracking of medical instruments and medical devices with marker attachments, where the markers are attached to the medical instrument in a plane that is not parallel to a longitudinal axis of the medical instrument, as further shown in (b) where full line of sight visibility of the markers is apparent.

**Figure 3** provides an isometric view of an example marker assembly connected to a medical instrument.

**Figure 4** is side view of the example marker assembly attached to the medical instrument, demonstrating the angle between the marker plane and the shaft of the  
5 medical instrument.

**Figure 5** provides (a) a view of the example marker assembly attached to the medical instrument, where the view is directed downward along the shaft of the medical instrument, such that the distal tip of the medical instrument is visible. (b) shows an illustration of the surgeon's point of view of the optically tracked surgical  
10 instrument for medical implants.

**Figure 6** shows (a) an example marker assembly based on a hinge joint, which allows the user to select any arbitrary angle between the connector and the marker arrangement, and (b) a detailed view of the individual components of the hinge joint.

**Figure 7** illustrates the possible angle settings using the hinge joint between  
15 the connector and the marker arrangement as shown in Figure 6.

**Figure 8** shows (a) an example marker assembly based on a hinge joint with notches and a spring which allows the user to select an angle from predefined angle settings between the connector and the marker arrangement, and (b) a detailed view of the individual components of the hinge joint.

**Figure 9** shows the example marker assembly from Figure 8, where the  
20 magnetic clamp mechanism is used instead of a spring.

**Figure 10** shows (a) an example marker assembly based on a hinge joint with a pin fixation which allows the user to select an angle from a set of predefined angles between the connector and the marker arrangement, and (b) a detailed view of the  
25 individual components of the hinge joint.

**Figure 11** shows (a) an example marker assembly based on a ball joint which allows the user to select any angle between the longitudinal axis of the medical instrument and the marker arrangement, and (b) a detailed view of the individual components of the ball joint.

5           **Figure 12** lists examples of open and closed ring shapes for the marker assembly.

**Figure 13** illustrates the two example types of medical instruments that differ by their handling by the surgeon, showing (a) an instrument that is twisted clockwise or counterclockwise by a small angle around its shaft, and (b) an instrument that is  
10 fully rotated several times.

**Figure 14** shows (a) an example marker assembly with a clamp that has two claws, which allows a fixed connection between the shaft of the medical instrument and the marker arrangement, and (b) a detailed view of the individual components of the clamping mechanism.

15           **Figure 15** shows the example marker assembly with a fixed connection between the shaft of the medical instrument and the marker arrangement based on a collet chuck adaptor, showing (a) the marker arrangement with the spring collet and the nose piece, (b) the marker assembly attached to the shaft of a medical instrument, and (c) a semi-transparent view of the attachment.

20           **Figure 16** shows (a) the example marker assembly attached to a rotatable medical instrument, where (b) shows that full rotation of the medical instrument is possible while the marker assembly is held.

**Figure 17** shows (a) the example marker assembly attached to a rotatable medical instrument, where only one stopper ring is used and (b) a semi-transparent  
25 view to show the position of the stopper ring inside the handle.

**Figure 18** shows components of an example embodiment of a marker assembly that allows the marker assembly to be removably attached to different medical instruments, showing (a) the marker assembly, (b) the connection adapter which is attached to each tracked medical instrument, and (c) a calibration tool to  
5 ensure that the same distance between the connection adapter and the tip of the medical instrument is obtained.

**Figure 19** shows detailed views of the marker assembly shown in Figure 18, showing (a) an external view of the assembled marker assembly, (b) an exploded assembly view, and (c) a semi-transparent view showing the internal components.

10 **Figures 20** (a) and (b) illustrate the placement of the connection adapter onto the medical instrument.

**Figure 21** illustrates the clamping of the marker assembly onto the medical instrument.

15 **Figure 22** illustrates the steps to secure the connection adapter on the shaft of the medical instrument using the calibration tool, including (a) placing the connection adapter inside the top bore of the calibration tool, (b) inserting the shaft of the medical instrument through the connection adapter, and (c) tightening the connection adapter to the instrument shaft when the shaft tip touches the bottom of the calibration tool.

20 **Figure 23** illustrates an alternative example embodiment of the connection adapter, which can be used for a fixed connection of the attachment to the medical instrument, showing (a) a connection adapter with an outer axial extension that is received in a corresponding groove with the inner sleeve, and (b) the compatibility of the inner sleeve with a cylindrically symmetric connection adapter for rotatable instruments.

**Figure 24** shows components of an example embodiment of a marker assembly that allows the marker assembly to be removably attached to different medical instruments, showing (a) the connection adapter which is attached to each tracked medical instrument, (b) the marker assembly with mechanical clamping mechanism, and (c) a semi-transparent view of the marker assembly to show the clamping mechanism inside the handle.

**Figure 25** illustrates the mechanical clamping of the marker assembly from Figure 24 onto the medical instrument, showing (a) a solid view and (b) a semi-transparent view.

**Figure 26** shows a typical set of tracked medical tools that are used during medical procedures including (a) a pedicle finder, (b) awl, and (c)-(e) various taps, for which the instruments shown in (c) to (e) are connectable to removably attachable marker assembly (f). In this example, the taps are used with the rotatable tracked attachment, while the pedicle finder and awl have a fixed attachment that is tracked.

**Figure 27** (a) shows a surgeon's hand holding the tracked tool with marker assembly in a suitable orientation for tracking. The marker assembly is at a suitable angulation from the rotatable tool shaft. (b) shows a cut-away view of the tool shaft, showing one particular embodiment of a spring-locked rapid exchange system configured for use with multiple tool tips. Example tool tip selections include (c) awl, (d) pedicle finder, (e) tap, and (f) variable length screws pre-mounted on screwdriver bits. In the embodiment shown, the distance between the tip location and the marker assembly is constant for maintaining calibration after tool tip exchange.

**Figure 28** shows a spring-locked exchange mechanism based on a spring collet for rapid exchangeable tool. (a) During use, the spring collet clicks on the notch

in the locking feature of the inserted tool extension. (b) For release, the outside cylinder is slid, spreading the spring collet with a coned notch.

### DETAILED DESCRIPTION

Various embodiments and aspects of the disclosure will be described with  
5 reference to details discussed below. The following description and drawings are illustrative of the disclosure and are not to be construed as limiting the disclosure. Numerous specific details are described to provide a thorough understanding of various embodiments of the present disclosure. However, in certain instances, well-known or conventional details are not described in order to provide a concise  
10 discussion of embodiments of the present disclosure. It should be understood that the order of the steps of the methods disclosed herein is immaterial so long as the methods remain operable. Moreover, two or more steps may be conducted simultaneously or in a different order than recited herein unless otherwise specified.

As used herein, the phrase “medical instrument” refers to any type of  
15 instrument or tool, which is used during surgery, diagnosis or other medical examinations or procedures and has a longitudinal axis. The longitudinal axis may be defined by a longitudinal shaft. Possible examples are surgical instruments such as awls, screwdrivers, pedicle finders, and cutters used for example in spinal surgeries. Further examples are drills and other tools in dentistry, needles for biopsy, and  
20 applicators for thermal therapies (including radiofrequency (RF) ablation, cryoablation, laser induced thermal therapy (LIT), or microwave ablation). One example for a non-surgical tool is a pointing stylus in image-guided procedures. Other non-limiting examples of surgical instruments include a section tip, shunt passer, scalpel/knife, scissor, forceps, bipolar, hook, retractor, dissector, drill, kerrison

rongeur, osteotome, needle, (microvascular) micro Doppler probe, screwdriver, monopolar, cusa, dilators, probe/stylus, bone impactor, K-wire, taps, speculum, and curette.

As used herein, the term “tracking system” is any device that allows the  
5 detection of the position and orientation of an object in three dimensions (3D). As a possible example, an optical tracking system operating with visual or infrared light may include stereo cameras to detect the positions of passive optical markers (e.g. reflective spheres) and/or active optical markers (e.g. light emitting diodes (LEDs)). Other non-limiting examples of tracking systems include electromagnetic tracking  
10 systems and structured light tracking systems.

As used herein, the term “marker” refers to a locating indicator that may be affixed or otherwise connected to a handheld implement, patient, subject, instrument, tool, or other component of a surgical system or surgical field, and which is detectable by a tracking system for use determining a position or location. A marker may be  
15 active or passive, and may be detectable using an optical detector. An example optical passive marker is a reflective sphere, or portion thereof, and an example active optical marker is an LED. Another example of a marker is a glyph, which may contain sufficient spatial and/or geometrical co-planar features for determining a three-dimensional position and orientation. For example, a glyph marker may include at  
20 least three corner features, where the three corner features define a plane.

As used herein, the term “marker plane” refers to the plane shared by one or more markers that are attached to a handheld implement, such that the tracking markers are suitable for determining a three-dimensional position and orientation of the handheld implement by the tracking system when the markers are secured to the

handheld implement. The marker plane may be defined at an angle relative to the shaft of the medical instrument.

As used herein, the term “overhead tracking system” refers to a tracking system that is located above an object to be tracked. An overhead tracking system  
5 may be directly overhead, substantially overhead, or overhead and laterally displaced. In some embodiments, a line of sight vector between the object to be tracked (e.g. a trackable handheld implement) and the tracking system is oriented at an angle of at least 45 degrees relative to a horizontal plane.

Figure 1 shows an illustration of an example of a surgical guidance system for  
10 tracking the intraoperative location and orientation of a medical instrument relative to patient anatomy during a spinal surgery. Patient 10 is shown in the prone position, with spine 15 exposed. The example system employs a combination of an optical tracking system and a structured light system.

The optical tracking subsystem is used to detect the position and orientation of  
15 medical instrument 40. In the example embodiment shown in Figure 1(a), the optical tracking subsystem includes stereo cameras with integrated infrared lighting 25 and attachment of highly reflective markers 65 to medical instrument 40. Due to their high reflectivity to infrared light, markers 65 can be easily localized in each image of the two cameras 25. These image positions are used to calculate the 3D position of each  
20 marker 65 by geometrical triangulation. The triangulation process can be performed by first calculating the center of mass of each of the detected markers in both camera views of the stereo calibrated camera system. This yields a set of marker points in both camera views from which the disparity between corresponding points in both views can then be calculated. This disparity along with the x and y pixel locations of  
25 each marker in one of the camera views can then be transformed into a 3D spatial

coordinate (in a relevant coordinate system) using a perspective transformation. If at least three markers 65 are rigidly attached to medical instrument 40, it is possible to compute its position and orientation (the six degrees of freedom – 6-DOF). It is to be understood that in some embodiments, less than three markers may be employed for position and location tracking. For example, a single marker may be provided for position and location tracking, provided that the single marker includes sufficient spatial structure and/or content. An example of such a single marker is a glyph including co-planar spatial features such as corner or edge features.

In the example illustrations provided herein, markers 65 for the optical tracking system are shown as reflective spheres, which are commonly used for passive optical tracking. However, any other type of markers, or marker attributes, can be used depending on the used tracking system such as, but not limited to, active markers (i.e. LEDs, which do not require integration of additional lighting) and passive markers (e.g. glyphs, varying marker color, varying marker size, varying marker shape).

The structured light imaging subsystem shown in the example embodiment is used to generate topology datasets with sub-millimeter accuracy. It includes at least one illumination device 30 and at least one camera 35. The illumination device(s) 30 project temporally and/or spatially modulated light onto the surface to be imaged, while the camera(s) 35 capture images of the illuminated surface. This active illumination enables robust and efficient identification of pixel correspondences between calibrated camera-projector (a projector may be thought of as an inverse camera) or calibrated camera-camera system. The correspondence (disparity) data can then be transformed into real-space coordinate data in reference frame of the calibrated camera(s) 35 and/or projector(s) 30 by geometrical triangulation. During

surgery, the structured light system is positioned such that 3D surface topology of the surgical site, such as bony surfaces of the exposed spine 15, is acquired and used to create a virtual representation of the exposed bone that is registered to pre-operative data (e.g. CT, MRI, US, PET, etc.) for continual surgical navigation.

5           In order to utilize the optical tracking data in conjunction with the structured light data, a calibration procedure can be employed to align the coordinate system of the optical tracking system to that of the structured light imaging system. If the relative position of the optical tracking system and the structured light imaging system is fixed, this calibration may be performed by obtaining the position of at-least 3  
10   points for a calibration object from both systems, and align the points to obtain the calibration transform. Alternatively, the structured light imaging device may include fiducial markers, which may be tracked by the optical tracking system itself. In this configuration, the transformation between the coordinate system of the optical tracking system and structured light imaging system is continuously updated.

15           The structured light datasets can be registered to preoperative 3D image data (e.g. computer tomography (CT) or magnetic resonance tomography (MRT) data) on the processing device 45 using methods described in patent application  
(PCT/CA2011/050257, the Detailed Description and Figures of which are incorporated herein by reference). With the calibration between the structured light  
20   and the optical system, the tracked position of the medical instrument 40 is projected into the preoperative 3D image data. The result is presented to the surgeon as an overlay 85 on the registered 3D image data on a display 55 or other visualization devices.

          As shown in Figure 1(a), tracking unit 20 is positioned in an overhead  
25   orientation, above exposed spine 15. During a surgical procedure, medical instrument

40 may be oriented such that its shaft 70 is not aligned perpendicular to the view axis of tracking unit 20 (as shown in the Figure). In such a situation, which involves direct, substantially overhead viewing (e.g. into or above a surgical incision), the performance of the tracking system, and the ability to track medical instrument 40, may suffer when the markers 65 are arranged with a marker plane that is parallel to the axis 70 of the instrument shaft.

This conventional arrangement of markers is shown in Figures 1(b) and 1(c). Figure 1(b) shows medical instrument 40 having handle 60 and shaft 70, with markers 65 attached in a plane that is substantially parallel to the axis of shaft 70. In Figure 1(b), the optical tracking cameras 25 are oriented in a conventional side viewing geometry, which is suitable for assessing the position and orientation of medical instrument 30 over a wide range of angular orientations. Such an approach is commonly used in conventional tracking systems that do not require a direct view above and/or into the surgical incision 75.

As shown in Figure 1(c), the conventional marker orientation is problematic when employed with the overhead, direct viewing system, (e.g. the overhead system shown in Figure 1(a)). In the scenario illustrated in Figure 1(c), in which cameras 25 are positioned above surgical incision 75, the conventional vertical plane marker arrangement leads to marker shadowing and/or occluding when medical instrument 40 is oriented near the vertical direction.

Figures 2(a) illustrates an embodiment of a surgical guidance system including tracking system 20, processing unit 45 (which is connectable to display 55), and medical instrument 40 including markers 65 that are oriented in a plane that is not parallel to the axis of medical instrument. Such an arrangement enables line of sight tracking of markers 65 over a wide range of angular orientations of medical

instrument 40. Display 55 may be integrated with the system (for example, integrated with processing unit 45 in a single device), or may be an external device to which the processing unit 45 is externally connected. Furthermore, as described further below, the system need not necessarily include medical instruments 40 with markers 65 permanently attached thereto, and may additionally or alternatively include a marker 65 attachment assembly that is configured to be removably attachable to one or more medical instruments 40.

Figure 2(b) provides an example embodiment showing relative positioning of the marker plane 85 and a longitudinal axis 70 of medical instrument 40. As can be seen in the Figure, markers 65 are provided in marker plane 85 that is not parallel to the longitudinal axis of medical instrument 40 (in the present example, the longitudinal axis is defined by shaft 70 of medical instrument 40). By orienting marker plane 85 such that it is an approximately horizontal plane for at least one potential intraoperative orientation of medical instrument 40, a direct line of sight may be maintained between cameras 25 and markers 65 over a wide variety of possible orientations of medical instrument 40.

Figure 3 illustrates one example implementation of a removable marker assembly 100 according to an embodiment of the disclosure, where marker assembly 100 is shown as being removably secured to shaft 130 of medical instrument 110, below handle 115. Marker assembly 100 includes a support member (140, 145) for supporting tracking markers 150, which are aligned in a plane defined by distal arc 145. In this example, instrument shaft 130 is inserted through a hole in connector 120. Set screws 125 secure marker assembly 100 to shaft 130, preventing sliding and rotation of the marker assembly 100. Although connector 120 is shown provided as an integral portion marker assembly 100, connector 120 may be provided as a separate

component that is slid, clamped, or otherwise secured to shaft 130, and may be separately interfaced or connected to marker assembly 100. Other example implementations of marker assembly 100 and connector 120 are described in more detail below.

5           The marker plane, as defined by distal arc 145, is angled relative to longitudinal axis 130, to enable line of sight detection of markers 150 by an overhead optical tracking system, over a wide range of overhead line-of-sight view angles. In the example embodiment shown in Figure 4, the marker plane, as defined by distal arc 145, is shown angled relative to longitudinal axis 130 such that the marker plane is  
10 approximately horizontal when medical instrument 110 is oriented at an angle relative to the horizontal plane.

As shown in Figure 4, distal arc 145 of marker assembly 100 is offset from longitudinal axis 130 by one or more proximal segments 140, which together with one or more distal segments 145, form a ring shaped structure. In some embodiments,  
15 proximal segments 140 may lie outside of the marker plane, as shown in the example provided in Figures 3 and 4. In some embodiments, proximal segments 140 extend from instrument shaft 130 along a direction that is approximately perpendicular to longitudinal axis 155 (or beyond perpendicular). This allows a user to grip shaft 130 beneath proximal segments 140, without proximal segments 140 contacting or  
20 pressing against the user's fingers. In other embodiments, one or more proximal segments extending from connector 120 may lie within the marker plane.

The ring structure, with dual members 140, provides rigid structural integrity and resistant to external torque, thereby providing a resilient assembly. Furthermore, the ring structure defines a hole 170 (shown in Figures 3 and 5) through which a  
25 surgeon or other user may look when operating with medical instrument 110 (as

shown in Figure 4). As can be seen in Figure 5(a), which illustrates the view from the perspective of the surgeon, the ring shape allows the surgeon a clear view on the distal tip 135 of the shaft 130 during the normal use of the medical instrument. The surgeon is therefore able to visibly check the incision or touching point of the medical instrument. This is illustrated in a sketch of the surgeon's view through the marker attachment in Figure 5(b). The surgeon's dominant hand for implant insertion (175) holds the handle of the tool while the non-dominant hand (180) resting on the edge of the surgical incision 75 aligns the tool shaft. A clear view on the distal tip 135 and the exposed spine 15 is obtained for the surgeon.

10           The angle between the instrument longitudinal axis 155 in Figure 4 and the marker plane can vary for different attachment designs depending on the type of medical instrument 110, and the range of insert angles of the instrument into the body. In one embodiment, the relative angle between the longitudinal axis and the marker plane may be determined as follows. A range of angles corresponding to typical use  
15           of the medical instrument 110 is first determined. The relative angle between the longitudinal axis 155 and the marker plane is then selected such that when the medical instrument 110 is oriented at the midpoint of this angular range, the marker plane is approximately orthogonal to the expected view axis of the overhead tracking system. In embodiments in which the view axis is approximately in the vertical direction (i.e.  
20           direct overhead viewing), then the marker plane is selected to be approximately horizontal.

          For example, the angular range for inserting pedicle screws during spinal surgery depends on the treatment area/level and is patient and disease specific since various diseases induce different kinds of spinal deformations. Surgical operation  
25           ergonomics dictate that typical surgical incisions occur directly in front of the

principle surgeon, with both hands in a comfortable position. The operating room light and other assistive devices (e.g., tracking system, LCD display, etc.) are typically maneuvered, by the surgeon's upper extremity, in an abducted and externally rotated position, along an arc that is approximately 120 cm to 150 cm in radius from the surgical incision. The surgeon's operative view has a surgical axis defined by his/her nasion and the center of the surgical incision. Accounting for potential obstruction by the surgeon's head, the optical axis (for operating room light or optical tracking system) can be located approximately 30° off the surgical axis (see 5 90 in Figure 2(a)). Given this geometrical consideration, coupled with operative experience, a range from approximately 50° to 70° for the relative angle between the longitudinal axis and the marker plane provides optimal tracking of the instruments used during pedicle screw placements.

It is to be understood that this angular range is provided as an example, and that for other types of medical instruments, the suitable angular range may differ. The suitable angle range for a given medical instrument may be determined by considering 15 the typical orientations of the medical instrument during use.

In the marker assembly shown in Figure 4, the relative angle between the longitudinal axis 155 of the medical instrument 110 and the marker plane is fixed. Further embodiments of the marker assembly allow the setting of various angles by 20 the user. The following embodiments provide some example implementations in which pivotable, tiltable, hinged and/or rotatable mechanisms are provided for varying the angular orientation of market assembly 100.

In one embodiment shown in Figures 6(a) and (b), a hinge joint 200 is employed to vary the angular orientation of marker assembly 100. Hinge joint 200 25 includes pivot member 202, which is integral with marker assembly 100, and which is

received between support members 204 and 206, which are integral to connector 120. Fixation screw 208 is placed through hole 205 in support member 204 and hole 203 in pivot member 202, and is received in threaded hole 207 in support member 206, such that support members 204 and 206 clamp pivot member 202 in place at a selected  
5 angle. This allows the user to select an arbitrary angle as shown in Figure 7. After fixing the angle with the fixation screw 208, the tool may be calibrated before tracking.

Fixation screw 208 provides but one example of a locking mechanism that may be employed to lock the angle of the pivotable marker assembly 100. For  
10 example, in another embodiment, shown in Figure 8, provides a hinge joint 210 that is pivotable among a series of pre-selected angular orientations. Pivot member 202 is supported between support members 204 and 206 on support bar 212. Pivot member 202, which includes notch structures 214, is biased by spring 216 towards corresponding notch structures 218 on support member 204. . The user can choose  
15 between certain pre-defined angle settings.

In another example embodiment shown in Figure 9, two magnets 225 and 230 are employed to provide a biasing mechanism for fixing marker assembly 100 at the selected angle. As a further modification of this embodiment, one of the two magnets 225 or 230 could be replaced by a magnetizable material.

20 In another embodiment shown in Figure 10, a hinge joint 230 includes locking pin 240 for fixation of pivotable marker assembly 100 in one of several possible angular orientations. A shown in Figure 10(b), fixation screw 210 is employed to support pivot member 202 between support members 204 and 206. Unlike the embodiment shown in Figure 6, however, pivot member is held in a fixed orientation  
25 by the placement of locking pin 240 with holes 232, 234 and 236 in support member

204, pivot member 202, and support member 206, respectively. Pivot member 202 includes a plurality of such holes, such that the angular orientation of marker assembly 100 may be varied without detaching marker assembly 100 from connector 120.

5           In the embodiment shown in Figure 11, a ball joint 250 is employed to pivotally secure marker arrangement 100 to connector 120. Ball joint 250 includes convex hemispherical member 252, which is attached to, or integral with, marker assembly 100, and which is received in concave hemispherical portion 252, that is attached to, or integral with, connector 120. A fixation screw 256 is received in  
10 threaded hole 258 within concave hemispherical portion 254 for securing ball joint 250 in a given angular orientation. Ball joint 250 allows the user to select an arbitrary angle between the longitudinal axis 155 of the medical instrument 110 and the marker plane.

          When the aforementioned embodiments with a variable angular orientation of  
15 marker assembly 100 are attached to a medical instrument and employed with a guidance system, it will generally be necessary to either calibrate the medical instrument or to select the calibration result from a list of previously performed calibrations prior to initiating tool tracking. Common methods of performing calibration include, but is not limited to inserting the tip of the tool 135 into multiple  
20 landmarks of a calibration block with known (calibrated) geometry, and pivot calibration, where the tool tip 135 is fixed in space, while the axis of the tool 155 is pivoted about the tip 135. Both these methods allow the tip 135 and axis 155 of the tool to be defined in terms of the markers 150. However, in some of the aforementioned embodiments in which a finite number of fixed angular orientations  
25 are available, it may possible to calibrate one of the many selectable angular

orientations, and to employ the known angular relationship among the different angular orientations to calibrate any of the other angular orientations.

The ring shape of marker assembly 100, shown in Figure 3 with a round arc, is but one non-limiting example implementation of many possible shapes for marker assembly 100. Figure 12 illustrates additional non-limiting example shapes and configurations with an open or closed ring shape. For example, Figure 12(a) shows a schematic of the round arc-shaped example marker assembly extending from connector 120. Other design examples are based on (b) a full circle shape, (c) a rectangular shape, (d) a triangular shape, and (e) a hexagonal polygonal shape. In other embodiments, marker assembly 100 may include an open gap, as shown in Figure 12(f), and/or have arms on each side with dissimilar shapes and/or lengths, as shown in Figure 12(g).

Embodiments of the marker assembly may be configured for attachment to different types of medical tools. Two example types of medical instruments with longitudinal shafts are shown in Figure 13, in which the illustrated medical instruments differ according to their handling by the surgeon. Figure 13(a) shows a first example instrument type, such as an awl or a pedicle finder 110, which are typically rotated, relative to the longitudinal axis of shaft 130, clockwise or counterclockwise 300 by less than approximately  $180^\circ$ . For such instruments 110, a fixed connection may be made between the instrument shaft and the marker assembly 100. As a consequence, the marker assembly 100 is rotated in unison with the medical instruments 110 around the shaft 130. If the rotation angle does not exceed  $180^\circ$ , the surgeon does not interrupt the ability of the optical tracking system to maintain line of sight visibility, and therefore, the tracking ability to track the instrument is maintained.

One example of a fixed connection is the insertion of the instrument shaft 130 through a hole in a connector block 120 and fixation of the arrangement with set-screws 125, such as in Figure 3. Another fixed connector with a marker arrangement 100 is a clamp 260 with two claws 265, which attaches to the longitudinal shaft 130 of the medical instrument 110 as shown in Figure 14. An additional fixation screw 270 could be used to squeeze the two claws 265 and thereby secure the connector tighter onto the instrument shaft 130.

Another fixed connector with a marker arrangement 100 is a collet chuck adaptor as shown in Figure 15. A spring collet 275 is fixed to, or integral with, marker assembly 100. After inserting shaft 130 of medical instrument 110, nose piece 280 fastens the spring collet 275, and thus marker assembly 100, to shaft 130.

A second type of medical instrument is shown in Figure 13(b), which includes, for example, screwdrivers and taps 400. These instruments are normally rotated several times in the same direction 305 around the longitudinal axis of the instrument shaft 405. For such instruments, the marker assembly may include a connection that allows a free rotation of the instrument shaft relative to marker assembly 100. For example, as described further below, the marker assembly and connector may include a portion that is clasped by the surgeon with one hand, providing support and enabling the surgeon to maintain the visibility of the marker assembly by the tracking system. This ensures that the surgeon does not block the line of sight of the tracking system on the tracking markers during rotation of the medical instrument 400. Accordingly, unintended blocking of line of sight on the markers by the arms of the surgeon is avoided, maintaining the ability to track the medical instrument 400 during use.

One example embodiment of such a connector is shown in Figure 16(a), which includes a pivotable marker assembly 410 with an inner hole that is sufficiently large

to accommodate the outer diameter of shaft 405 of medical instrument 400. Stopper rings 415 and 425 (optionally secured with fasteners such as set-screws), or other structures along the instrument shaft, fix or limit the relative position of the pivotable marker assembly 410 along instrument shaft 405. As illustrated in Figure 16(b),  
5 during surgical use, the surgeon clasps the elongate cylindrical portion 420 of pivotable marker assembly 410 with one hand, while the other hand can be used to rotate medical tool 400 by grasping handle 430.

It should be recognized that variations and modifications of the mechanism for connection between the marker assembly 410 and shaft 405 of the medical instrument  
10 400 may be implemented. For example, one ring 445 can be integrated into the pivotable cylindrical portion 435 of the marker assembly 410 as shown in Figure 17. The ring 445 is secured with fasteners such as set-screws (using the hole 440) and fix of the pivotable marker assembly 410 along shaft 405 of the medical instrument 400.

Many commercially available tracking systems are compatible with limited  
15 arrangements of markers on tracking attachments. For example, optical tracking systems that employ passive spherical optical markers typically require a minimal distance between markers and specific variations in the distances between marker pairs in order to track multiple instruments. As a consequence, the relative spacing of the markers becomes larger with the number of tracked instruments when each  
20 instrument is tracked with an individual marker arrangement. Unfortunately, larger marker attachments make it more difficult and less convenient for the surgeon to handle the medical instruments.

In one embodiment, a connection adapter is attached to, or provided as part of, the medical instrument itself (for example, permanently affixed to the shaft, or formed  
25 as a monolithic component of the shaft), such that the connection adapter is

configured to mate with, or otherwise connect to, the removably attachable marker assembly. Multiple connection adapters, each having a common outer cross-section (cross-sectional profile), may be provided, for attachment to multiple medical instruments. Such an embodiment enables one marker assembly to be used for a  
5 plurality of different medical instruments, even if the shaft diameter, or shaft length, differs among the medical instruments.

Accordingly, in one example embodiment, which may be employed to reduce the number of marker assemblies needed for tracking of multiple medical instruments, a connection adaptor is integrated with, or attached to, one or more medical  
10 instruments to be tracked, where the connector allows the coupling and removal of one marker assembly to multiple medical instruments. In some embodiments, the coupling mechanism may support the repeated coupling and decoupling of the marker assembly to multiple medical instruments without the need for recalibration.

Figures 18-21 illustrate an example embodiment of a removably attachable  
15 marker assembly in which magnetic clamping is employed to secure an attachment assembly to a connection adapted attached to the shaft of a medical instrument. A first component is marker assembly 500, which includes handle 505 and marker support 510. During use, handle 505 is held by the surgeon with one hand, as described in the previous section. Handle 505 includes bore 515 extending below the top of the device.

20 Connection adapter 520 is a cylinder formed, at least in part, from a magnetic material, such as a diamagnetic, paramagnetic, or ferromagnetic material. In one example embodiment, connection adapter 520 may be formed from magnetic steel. Connection adapter 520 is placed around and secured to the shaft of the medical instrument. Connection adapter 520 may then be rotatably received within bore 515  
25 within handle 505 in order to indirectly couple marker assembly 510 to the medical

instrument. As further described below, an integrated magnet within handle 505 secures magnetic connection adapter 520 via an attractive magnetic force, thereby removably attaching marker assembly 510 to the medical instrument. An additional calibration tool 600, described in further detail in Figure 22, allows the positioning of connection adapter 520 at a well-defined distance along the shaft from the tip of the medical instrument, allowing exchanging of marker assembly 500 among multiple pre-calibrated medical instruments without the need for intraoperative re-calibration.

Figure 19 illustrates an example implementation of the internal components of marker assembly 500 (shown in from an external perspective in Figure 19(a)). In Figure 19(b), an exploded view of the internal assembly is provided, showing internal sleeve 525, which is also formed from a magnetic material and includes providing inner bore 515 for receiving connection adaptor 520. Ring magnet 530 is supported below counter piece 525 above end cap 535. Ring magnet 530 has an outside-diameter larger than the diameter of bore 515, and an inside diameter that is larger than the diameter of the largest shaft associated with the medical instruments to which the marker assembly is to be removably attached. A semi-transparent view through assembled marker assembly 500 is illustrated in Figure 19(c), showing the position of internal sleeve 525, ring magnet 530 and fixation end cap 535 inside handle 505.

The operation of rotatable marker assembly 500 is described as follows. For each medical instrument 400 in a set of instruments to be tracked during surgery, a connection adapter 520 is provided and secured to the instrument shaft (as shown in Figure 20). Each connection adapter 520 has an inside bore configured to receive the shaft 405 of its corresponding medical instrument 400. As shown in Figure 20(a), the connection adapter 520 is slid along the shaft 405 of the medical instrument 400.

Connection adapter 520 is then fixed with set-screws 540 at the desired position on the instrument shaft 405 as seen in Figure 20(b).

Marker assembly 500 is then slid over connection adapter 520 and detachably secured in place, as shown in Figure 21(a) and 21(b). To clamp medical instrument 5 400 to marker assembly 500, the instrument shaft 405 and connection adapter 520 are inserted through the bore 515 of within internal sleeve 525. As shown in the semi-transparent view of Figure 21(b), connection adapter 520 is directly clamped to ring magnet 525 inside marker assembly 500. If the position of connection adapter 520 is not changed, the relationship between marker assembly 500 and the medical 10 instrument 400 is well-defined and reproducible as required for the tracking of the instrument. Marker assembly 500 thereby enables the tracking of the trajectory of the instrument shaft 405 via an overhead optical tracking system.

This approach is efficient to track medical instrument 400 after the calibration, using the calibration procedures of the specific tracking system. The approach can 15 also be used to track the trajectory of multiple instruments using the same marker attachment.

However, if tracking of the trajectory and the tip multiple medical instruments is desired, the position of connection adapter 500 on the shaft 405 of each medical instrument 400 may be calibrated such that the distance between the connection 20 adapter 520 and the tip of each medical instrument is substantially equal.

This may be achieved, in one example embodiment, using a calibration tool. For example, calibration tool 600, shown in Figure 18(c), may be employed to connect the connection adapter 520 to the shaft 405 of the medical instrument 400, as demonstrated in Figure 22. Connection adapter 520 is initially placed into the top hole 25 605 of calibration tool 600, and is inserted until its motion is impeded by stop 610,

which is a location at which the inner diameter of calibration tool 600 decreases from the outer diameter of connection adapter 520 to a smaller diameter, which is larger than the diameter of the largest shaft used in a medical instrument set. Accordingly, after the connection adapter 520 is fully slid into the hole 605, it is located with a  
5 well-defined distance relative to the bottom 615 of calibration tool 600.

Shaft 405 of the medical instrument 400 is then inserted through the bore 545 in connection adapter 520, until the tip of the instrument shaft 405 encounters the bottom 615 of calibration tool 600. Afterwards, as shown in Figure 22(c), set-screws 540 of connection adapter 520 are tightened, thereby securing connection adapter 520  
10 to the medical tool 400. Using this approach ensures that connection adapter 520 is always positioned in the same distance from the shaft tip of the medical instrument 400, and therefore, a re-calibration of the medical instrument 400 is not necessary.

The aforementioned devices and methods allow tracking of multiple medical instruments with one attachment (or a plurality of attachments, if so desired),  
15 provided that connection adapter 520 of each instrument is initially placed at a pre-calibrated location. This may be achieved, for example, using calibration tool 600 and following the procedure as shown in Figure 21. In addition, no re-calibration is necessary for future uses of the tool (e.g. for the next surgery), provided that the connection adapters are either left on the medical instruments or removed and  
20 replaced using the calibration tool.

While the aforementioned embodiments provided rotatable marker attachments, a locking mechanism may be employed to a further modification of the above embodiment to prevent the rotation of certain medical instruments inside the attachment. An example implementation of this embodiment is shown in Figure 23(a).  
25 Connection adapter 550 has a non-cylindrically symmetric feature for locking an

orientation of the medical instrument within the bore of the internal sleeve 560. For example, as shown in the Figure, the non-symmetric feature may be a line of increased thickness 555 of the surface of connection adapter 550, on the outside surface, parallel to the cylinder axis, which is axially received in corresponding  
5 grooves 565 within internal sleeve 560. This embodiment also accommodates the previously described rotatable connection adapter 520, as shown in Figure 23(b), because groove 565 in internal sleeve 560 does not impede rotation of connection adapter 520. Accordingly, the presence of such non-cylindrically symmetric features on a given connection adapter determines whether or not the corresponding medical  
10 instrument has a fixed or a rotatable connection to its marker assembly.

Another embodiment, shown in Figure 24, employs mechanical clamping instead of the magnetic clamping to removably attach the marker assembly to the shaft 405 of the medical instrument 400. For example, as shown in the Figure, connection adapter 700 (which may be a metallic cylinder) can include a groove 705  
15 for receiving a clamping fastener. Connection adapter 700 is placed and secured to the shaft 405 of the medical instrument 400, in a manner similar to the procedure described in Figure 20. An additional calibration tool can be used to position the connection adapter 700 at a well-defined distance along the shaft from the tip 450 of the medical instrument 400, in a manner similar to the procedure shown in Figure 22.

20 Marker assembly 710 has an insert hole 715 with the same diameter as the outside diameter of the connection adapter 700. Inside marker assembly 710 is a sliding plate 720 with a hole with the same diameter as the connector adaptor 700, as can be seen in Figure 24(c). Two springs 730 hold this sliding plate 720 in a default position, shown in Figure 24(c), in which axis of hole 725 is slightly off-centered  
25 relative to axis of hole 715 of marker assembly 710.

Figure 25 illustrates the process of clamping connection adapter 700 within marker assembly 710, where connection adapter 700 is secured to shaft 405 of medical instrument 400. In order for marker assembly 710 to be able to receive connection adapter 700 in an unobstructed fashion within hole 715, the user presses sliding plate 720, thereby compressing springs 730 to align the axis of hole 725 with the axis of hole 715. After aligning the hole axes, connection adaptor 700 may be fully inserted into hole 715 of marker assembly 710. The user may then release sliding plate 720 to its default position, such that a proximal portion of sliding plate 720 engages groove 705 and secures the axial position of marker assembly 710.

The example clamping mechanism illustrated in Figures 24 and 25 is suitable for use with medical instruments which involve rotation during use. If it is preferable that a medical instrument should not be rotatable inside the attachment, a groove in a manner similar to one shown in Figure 23 can be added to the device. It is also to be understood that the embodiment shown in Figures 24 and 25 is merely one example embodiment of a mechanical clamping mechanism, and that a wide range of other mechanical clamping mechanisms may be alternatively or additionally employed. For example, other detent mechanisms and/or fasteners (such as set screws) may be employed for mechanical clamping, with or without allowing rotation of connection adapter 700 within hole 715 of marker assembly 710. In other example implementations, the marker assembly may be removably secured to the shaft a suitable engagement mechanism such as mating threads or other interlocking features and/or securing the marker assembly using a friction fit.

The above embodiments can be combined to track an entire set of different medical instruments, for example, during surgery. One example is the set of medical instruments used during pedicle screw placement in spine surgery, shown in Figure

26. This set can include an awl 800, a cutter 810, taps of different sizes 830 and 840, and screwdrivers 850. Since the awl 800 and the cutter 810 are normally twisted back and forth by a smaller rotation angle, two attachment designs with fixed connectors are used (Figures 15 (a) and (b)), which have different arrangements of markers (805  
5 and 815) for instrument identification.

In this example, reflective spheres are used as markers for an optical tracking system. To reduce the impact of the marker attachment on the surgeon, a round-arc shape of the marker support is used. In addition, the attachments of the awl 800 and cutter 810 have the same dimensions, use a set of markers with a slightly different  
10 geometric arrangement, and are chosen to be as small as possible to reduce overall weight and visual impact on the surgical field of view.

In the present example embodiment, the surgeon may change marker assemblies between varying sizes of taps 830 and 840 and the screwdriver 850 quite frequently during the surgery. These instruments are also normally rotated several  
15 times around the instrument shaft. For these instruments the previously described exchangeable attachment device with a rotatable connection 500 is preferred. As can be seen in Figure 26, each of these instruments is connected to a corresponding connection adapter 835, 845 and 855. The connection adapters in this illustration are placed with the calibration tool and have therefore the same distance to the tip of each  
20 respective instrument shaft.

Alternatively, in some situations, it is not necessary during navigated procedures for the surgeons to know the tip location of their tool for image guidance – the tool trajectory alone is sufficient. Therefore other medical tools, whose tip location has not been calibrated to the adaptor, can still be used for navigation,

provided that the adaptor fits snugly around the bore of the tool such that the axis of the tool is aligned to the intended axis (trajectory) of the adaptor.

As mentioned above, for some marker types, the relative spacing of the markers becomes larger with the number of simultaneously tracked instruments. Two types of attachments have been described, one of which is specifically designed to fit one tool 100, and the other is an exchangeable attachment 500 that can be attached to multiple tools. In one example application, given the complete set of tools available to the surgeon, the exchangeable attachment may employ a marker arrangement where the spacing of the markers is large compared to the non-swappable marker attachment. .

Such an embodiment may be useful when the exchangeable attachment is held relatively stationary by the surgeon, and only the tool itself is rotated, such that the arc of motion (sweep area) of the exchangeable attachment is small. Therefore, the marker support 510 can be relatively large, whereas for the non-swappable marker attachment, a large marker support would sweep out a much larger area when performing clockwise and anti-clockwise rotations, and would therefore be more obstructive. Furthermore, since the exchangeable attachment is held by the surgeon's hand, as shown in Figure 16(b), the hand can obstruct part of the surgeon's view of field through the marker support. Therefore it may be useful to have a marker support with a larger opening for the exchangeable attachment.

Referring now to Figure 27, an embodiment is illustrated in which a marker assembly 900 is attached to a rapid exchange handheld tool body 910, and where the shaft of the tool body 910 is configured for use with a plurality of exchangeable tool extensions, such as bits and/or fasteners. As shown in the Figure, a marker assembly 900 is secured (permanently or removably) to the rapid exchange tool 910. The

marker assembly 900 may be provided according to any of the preceding embodiments.

The Figure illustrates an embodiment in which a spring-locked exchange mechanism 920 is employed for rapid exchange of a bit, fastener, combination  
5 thereof, or other exchangeable tool extension or combination thereof. For example, when employed with awl 940, a proximal portion 942 of the shaft of awl 940 is received within longitudinal bore 925 of shaft 930, and is secured in place by the spring-locked mechanism 920. Referring to Figure 27(b) and (c), the proximal portion  
10 942 of awl 940 includes locking features 944 that cooperate with corresponding features in spring-locked mechanism 920.

As shown in Figure 28, the connector for the spring-locked exchange mechanism could be based on spring collet 920. The spring collet 920 clicks on the notch in the locking feature 944, when a tool extension 940, 950, 960, 970, or 980 is inserted into the rapid exchange tool 910 as shown in Figure 28(a). The spring collet  
15 920 is covered by a cylinder 930 which has a coned notch 995 in the inside pointing towards the spring collet 920. If the cylinder 930 is pressed towards the rapid exchangeable tool 910 as shown in Figure 28(b), the coned notch 995 spreads the spring collet 920 and releases the tool extension 940, 950, 960, or 980. Afterwards another tool extension can be inserted into the rapid exchange tool 910. It is to be  
20 understood that the spring-locked mechanism illustrated in Figure 27 is but one example implementation of a mechanism for removably securing a bit, fastener, or other functional element to rapid exchange tool 910. Other suitable and example implementations/mechanisms include thread-lock, magnetic, or pneumatic mechanisms. In one embodiment, mechanical contact between the outer shaft of the  
25 distal functional element and the inner bore 925 of shaft 930 and utilizes compression

and static friction. Other embodiments may include thread-lock, clip-lock, or pneumatic lock techniques.

According to one embodiment, the rapid exchange device described above may be employed for tracking fasteners of variable lengths, such as implantable screws 965 and 975 in Figure 27(f). In one embodiment, screws 965 and 975 may be pre-mounted on screwdriver tips 970 and 980, where the lengths of screwdriver tips 970 and 980 are provided such that the tip locations 990 of the screws remain invariant relative to the position of marker assembly 900, thus preserving the calibration of location 990 under exchange of the different screwdriver and screw assemblies. This embodiment thus allows for tracking of the tip location of an exchangeable tool extension that includes a tool extension member (such as a screwdriver extension) and a functional member (such as a screw) removably attached to the tool extension member, where calibrated tracking may be maintained without the need for further calibration despite the use of functional members having different lengths.

Figures 27(c)-(e) illustrate other examples of exchangeable distal functional elements, , include awl 940, pedicle finder 950, tap 960, with the location of the tip being invariant with respect to the marker assembly 900.

In other embodiments, the relative location between the tip 990 of the installed functional extension need not be fixed relative to the location of marker assembly 900, provided that the relative location is provided to the tracking system. For example, the tracking system may be pre-programmed with the relative locations of the distal tip of various exchangeable tool extensions, such that when a rapid exchange procedure is performed and a first exchangeable tool extension is removed and replaced with a second exchangeable tool extension, the system can select the

appropriate calibration data for the second exchangeable tool extension from the pre-programmed calibration data.

The aforementioned marker assemblies and related devices may be employed for tracking medical instruments, for example, for computer-aided navigation of, or  
5 for, various medical methods and procedures. As mentioned above, many medical instruments, such as awls, cutters, screwdrivers or drills can be tracked using the aforementioned marker assemblies. This allows the use of navigation of, or to support, various surgeries including for example spine, hip, knee, and brain surgeries, where a direct view on the corresponding bone surface is possible. It is to be  
10 understood that the aforementioned examples may be for a wide variety of medical applications beyond surgery, such as guidance during the positioning of applicators for thermal therapies or navigation of biopsy needles.

Although the preceding embodiments have been described as example implementations involving medical applications, it is to be understood that the marker  
15 assemblies described above may be employed for the tracking of any handheld implement. Examples of other trackable handheld implements include tools and video game controllers, such as those that have a longitudinal shaft, longitudinal body, longitudinal member, or longitudinal axis.

For example, in one embodiment, the devices, systems and methods disclosed  
20 above can be adapted for the tracking of a video/computer game controller or handpiece. In one example implementation, a video game controller tracking system could be mounted on the ceiling above a group of players, who use tracked controllers such as styluses or other controllers to interact with different elements of the game. The ceiling-mounted tracking system would enable the tracking, without obstruction,  
25 of all the players' controllers. In another example embodiment, the tracking system

could be integrated with a monitor, such that during gameplay, a player points a tracked stylus at the tracking system in order to interact with the virtual components of the game (for example a hunting simulator).

In another example implementation, the tracked stylus could also be used in  
5 combination with a monitor, computer, and tracking cameras to be used a  
rehabilitation device, where the user would be asked to perform a set of spatial tasks  
such as connecting virtual dots or tracing out virtual objects projected onto the  
monitor showing the user, the virtual objects and their environment. This  
rehabilitation system could be used to track the progression/regression of patients  
10 with uncontrollable movement such as Parkinson's disease based on their interaction  
with the system as a function of time.

**THEREFORE WHAT IS CLAIMED IS:**

1. A marker assembly for locating a handheld implement, the marker assembly comprising:

a support member;

at one or more tracking markers affixed to said support member, said tracking markers defining a marker plane; and

a connector configured to removably attach said support member to a longitudinal portion of the handheld implement, the longitudinal portion defining a longitudinal axis;

wherein said marker plane is not parallel to the longitudinal axis when said marker assembly is secured to the handheld implement; and

wherein said one or more tracking markers are suitable for locating a three-dimensional position and orientation of said handheld implement when said marker assembly is secured to said handheld implement.

2. The marker assembly according to claim 1 wherein said marker plane is angled relative to the longitudinal axis such that said tracking markers are visible to an overhead tracking system over a pre-defined range of angular orientations of the handheld implement.

3. The marker assembly according to claim 2 wherein said marker plane is angled relative to the longitudinal axis such when the handheld implement is positioned at a mid-point of the pre-defined range, a view axis of the overhead tracking system is approximately orthogonal to said marker plane.

4. The marker assembly according to claim 2 or 3 wherein the pre-defined range of angles is associated with a medical procedure.
5. The marker assembly according to claim 4 wherein the medical procedure is the insertion of a pedicle screw.
6. The marker assembly according to any one of claims 1 to 5 wherein said tracking markers are passive optical markers or active optical markers.
7. The marker assembly according to any one of claims 1 to 6 wherein said support member further comprises a ring-shaped member, said ring-shaped member supporting said tracking markers.
8. The marker assembly according to claim 7 wherein said ring-shaped member is shaped as a closed ring or an open ring.
9. The marker assembly according to claim 7 wherein said ring-shaped member defines a central aperture through which a distal portion of the handheld implement is visible by a user when said marker assembly is secured to the handheld implement.
10. The marker assembly according to any one of claims 1 to 9 wherein said connector comprises one or more fasteners for securing said marker assembly to the handheld implement.

11. The marker assembly according to any one of claims 1 to 10 wherein said support member comprises one or more proximal segments attached to said connector and one or more distal support segments attached to said one or more proximal segments, wherein said tracking markers are supported on said distal support segments, and wherein said one or more proximal segments are not co-planar to said distal support segments.

12. The marker assembly according to claim 11 wherein said one or more proximal segments lie in a plane that is approximately orthogonal to the longitudinal axis when said marker assembly is secured to the handheld implement.

13. The marker assembly according to any one of claims 1 to 11 wherein said connector is configured to allow free rotation of the handheld implement relative to said connector.

14. The marker assembly according to any one of claims 1 to 12 wherein said connector comprises a collet chuck adaptor.

15. The marker assembly according to any one of claims 1 to 14 further comprising a mechanism for varying an angle of said marker plane relative to the longitudinal axis.

16. The marker assembly according to claim 15 wherein said mechanism is a hinge mechanism.

17. The marker assembly according to claim 15 wherein said mechanism is a pivotable mechanism.

18. The marker assembly according to claim 17 wherein said pivotable mechanism is configured for locking an angle of said marker plane in one or more pre-selected angles.

19. The marker assembly according to any one of claims 1 to 18 wherein said connector comprises a longitudinal portion configured to be gripped by a hand.

20. The marker assembly according to any one of claims 1 to 19 wherein the handheld implement is a medical instrument.

21. An interchangeable marker system for tracking a plurality of handheld implements, the system comprising:

a plurality of connection adapters, wherein each connection adapter is attached to, or attachable to, a longitudinal shaft of one of the handheld implements, and wherein said connection adapters have a common outer cross-section; and

a marker assembly comprising:

a longitudinal body having an inner bore suitable for receiving one of said connection adapters;

a connection mechanism for connecting said longitudinal body to said connection adapter;

a support member connected to said longitudinal body; and

one or more tracking markers affixed to said support member, said tracking markers defining a marker plane;

wherein said marker assembly is removably attachable to each of the handheld implements through said connection adapters; and

wherein said one or more tracking markers are suitable for locating a three-dimensional position and orientation of said handheld implement when said marker assembly is secured to said handheld implement.

22. The interchangeable marker system according to claim 21 wherein said marker plane is not parallel to a longitudinal axis of the longitudinal shaft when said marker assembly is secured to the handheld implement.

23. The interchangeable marker system according to claim 21 wherein said marker plane is angled relative to the longitudinal axis such that said tracking markers are visible to an overhead tracking system over a pre-defined range of angular orientations of the handheld implement.

24. The interchangeable marker system according to claim 23 wherein said marker plane is angled relative to the longitudinal axis such when the handheld implement is positioned at a mid-point of the pre-defined range, a view axis of the overhead tracking system is approximately orthogonal to said marker plane.

25. The interchangeable marker system according to any one of claims 21 to 24 wherein said support member comprises a ring-shaped member, said ring-shaped member supporting said tracking markers.

26. The interchangeable marker system according to claim 25 wherein said ring-shaped member is shaped as a closed ring or an open ring.

27. The interchangeable marker system according to claim 25 wherein said ring-shaped member defines a central aperture through which a distal portion of the handheld implement is visible by a user when said marker assembly is secured to the handheld implement.

28. The interchangeable marker system according to any one of claims 21 to 27 wherein each connection adapter comprises a substantially hollow cylindrical body;

wherein said hollow cylindrical body of each connection adapter is configured to slidably receive a longitudinal shaft of one of the handheld implements there within, such that each connection adapter is attached to, or attachable to, one of the handheld implements; and

wherein said connection adapters have a common outer diameter.

29. The interchangeable marker system according to claim 28 wherein said connection mechanism comprises a magnetic clamping mechanism.

30. The interchangeable marker system according to claim 29 wherein said inner bore of said longitudinal body comprises a first inner bore and a second inner bore, wherein said first inner bore has a diameter suitable for receiving one of said connection adapters and wherein said second inner bore portion has diameter larger

than a diameter of said first inner bore, and wherein said magnetic clamping mechanism comprises:

a ring magnet located within said second inner bore, wherein an inner diameter of said ring magnet is larger than an outer diameter of the longitudinal shaft of each handheld implement, and smaller than an outer diameter of each connection adapter;

wherein said connection adapters and portion of said longitudinal body surrounding said first inner bore comprise a magnetic material such that when one of said connection adapters is received into said first inner bore, said connection adapter is removably secured within said longitudinal body by said ring magnet.

31. The interchangeable marker system according to any one of claims 28 to 30 wherein an outer surface of at least one of said connection adapters and said inner bore of said longitudinal body comprise surface features configured to prevent rotation of said connection adapter when said connection adapter is housed within said inner bore.

32. The interchangeable marker system according to claim 31 wherein said surface features comprise an axial channel recessed within a surface of said inner bore and an axial projection provided on an external surface of said at least one connection adapter, wherein said axial channel is configured to receive said axial projection.

33. The interchangeable marker system according to any one of claims 21 to 32 further comprising a calibration tool for calibrating a longitudinal position of one of

said connection adapters on a longitudinal shaft of one of said handheld implements, said calibration tool comprising:

a longitudinal body having a central bore, wherein said central bore comprises a first central bore and a second central bore, and a bottom;

wherein said first central bore has a first cross-section suitable for receiving one of said connection adapters; and

wherein said second central bore portion has a second cross-section smaller than said first cross-section, and wherein said second cross-section is sufficiently large to receive a longitudinal shaft of any one of said one or more handheld implements,

such that when the longitudinal shaft is inserted into said calibration tool and contacted with said bottom, the distance between a distal end of the longitudinal shaft and the connection adapter housed within said first central bore is independent of the length of the longitudinal shaft.

34. The interchangeable marker system according to any one of claims 21 to 33 wherein said longitudinal body is configured as a handle for gripping by a user.

35. A guidance system for tracking one or more handheld implements, said guidance system comprising:

a marker assembly according to any one of claims 1 to 20;

a tracking system configured to detect a signal associated with each tracking marker, wherein said tracking system is positioned in a substantially overhead configuration; and

a processor configured to receive said signals and to calculate a relative position and orientation of the handheld implement based on said signals, when said marker assembly is secured to the handheld implement.

36. The guidance system according to claim 35 wherein said tracking system is positioned above or overhead of said marker assembly during use.

37. The guidance system according to claim 35 wherein a view axis of said tracking system is approximately orthogonal to said marker plane.

38. A trackable handheld device comprising:

a handheld implement comprising a longitudinal shaft, the longitudinal shaft defining a longitudinal axis;

a support member connected to the longitudinal shaft; and

one or more tracking markers affixed to said support member, said tracking markers defining a marker plane;

wherein said marker plane is not parallel to the longitudinal axis, such that said tracking markers are visible to an overhead tracking system during use of said handheld implement; and

wherein said one or more tracking markers are suitable for locating a three-dimensional position and orientation of said handheld implement by the overhead tracking system.

39. A trackable tool system comprising:

a plurality of exchangeable tool extensions, each exchangeable tool extension having a proximal portion, a distal functional end, and a longitudinal axis;

a handheld body adapted to detachably secure each exchangeable tool extension at said proximal portion thereof, such that one exchangeable tool extension may be secured to said handheld body at any given time;

a support member connected to said handheld body; and

one or more tracking markers affixed to said support member, said tracking markers defining a marker plane;

wherein each exchangeable tool extension has common length, such that when a first exchangeable tool extension is replaced with a second exchangeable tool extension, said one or more tracking markers are suitable for locating a three-dimensional position of said distal functional end of said second exchangeable tool extension and an orientation said second exchangeable tool extension by a tracking system without recalibration.

40. The trackable tool system according to claim 39 wherein said handheld body comprises a spring-locked mechanism for detachably securing said exchangeable tool extensions.

41. The trackable tool system according to claim 39 wherein one or more of said exchangeable tool extensions is a single member.

42. The trackable tool system according to claim 39 wherein one or more of said exchangeable tool extensions comprises:

a tool extension member configured to be detachably secured to said handheld body; and

a functional member detachably secured to said tool extension member;

wherein said common length includes the length of said tool extension member and said functional member.

43. The trackable tool system according to claim 42 wherein the tool extension member is a screwdriver extension member, and wherein the functional member is a screw.

44. The trackable tool system according to claim 42 wherein said functional member is a fastener.

45. The trackable tool system according to claim 39 wherein said marker plane is not parallel to the longitudinal axis, such that said tracking markers are visible to an overhead tracking system.

46. A guidance system for tracking one or more handheld implements, said guidance system comprising:

a trackable handheld device according to claim 38;

a tracking system configured to detect a signal associated with each tracking marker, wherein said tracking system is positioned in a substantially overhead configuration; and

a processor configured to receive said signals and to calculate a relative position and orientation of said handheld implement based on said signals, when said support member is secured to said handheld implement.

47. A guidance system for tracking one or more handheld implements, said guidance system comprising:

an interchangeable marker system according to any one of claims 21 to 34;

a tracking system configured to detect a signal associated with each tracking marker, wherein said tracking system is positioned in a substantially overhead configuration; and

a processor configured to receive said signals and to calculate a relative position and orientation of the handheld implement based on said signals, when said marker assembly is secured to the handheld implement.

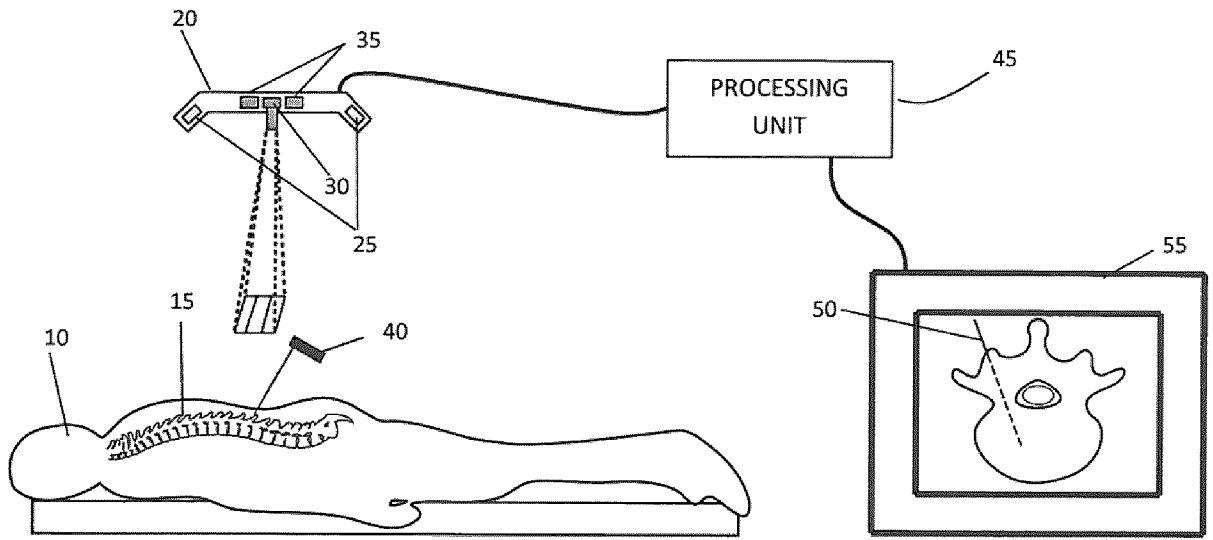

Figure 1 (a)

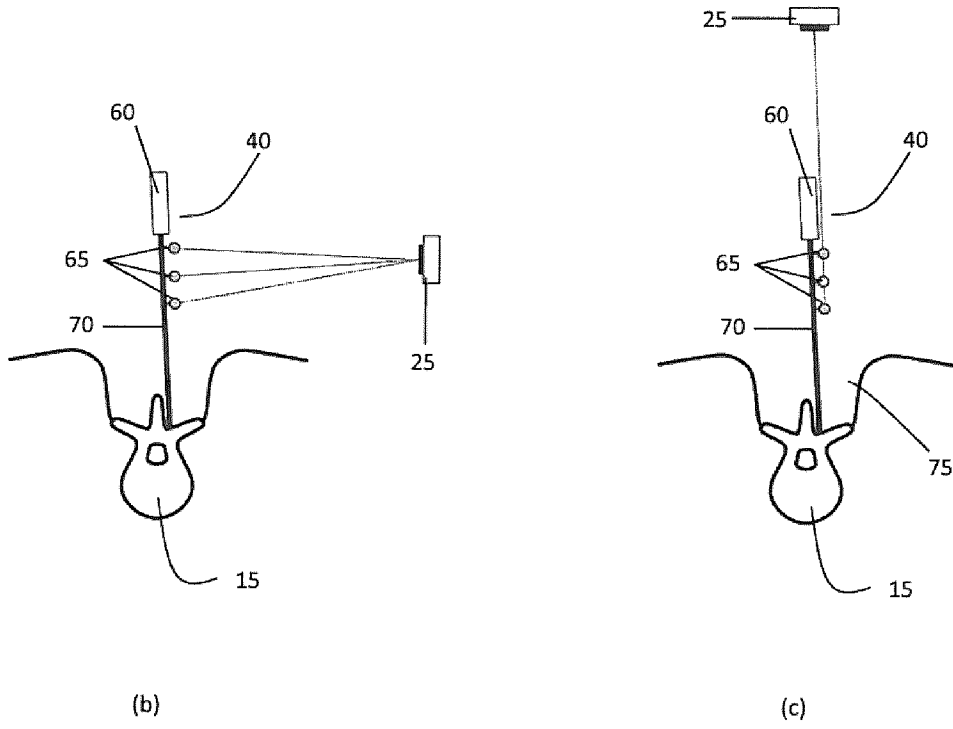

Figure 1 (Cont')

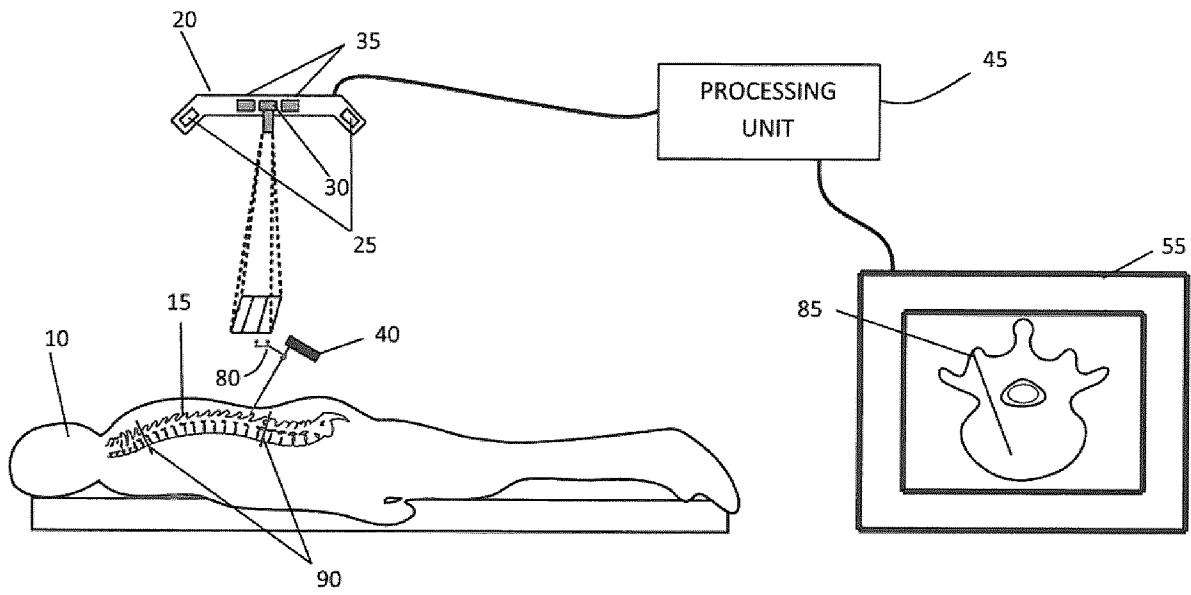

Figure 2(a)

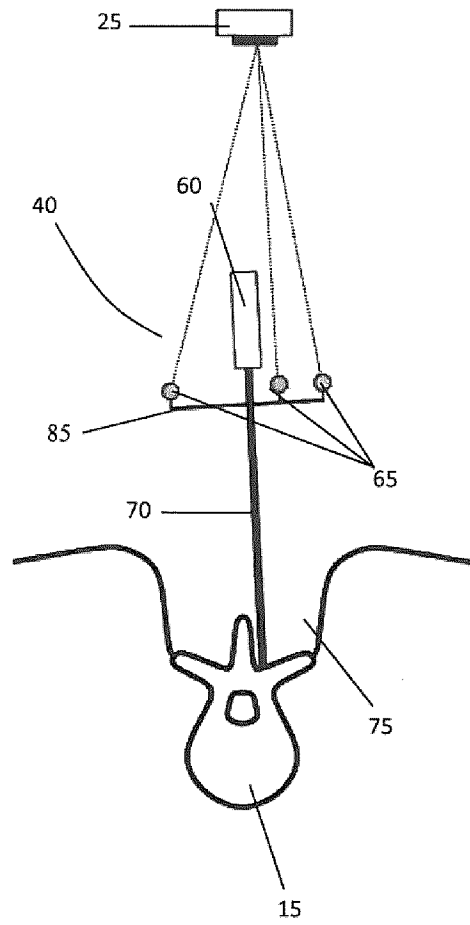

Figure 2(b)

5/32

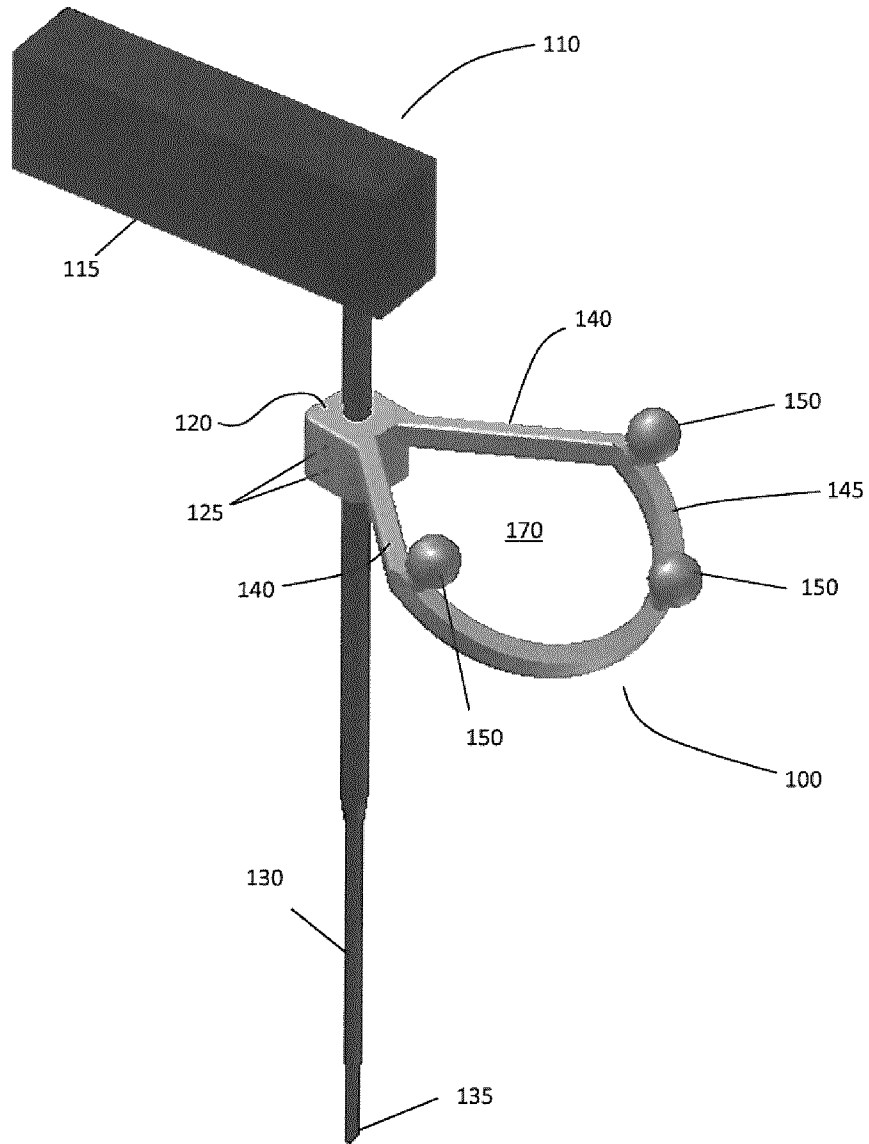

Figure 3

6/32

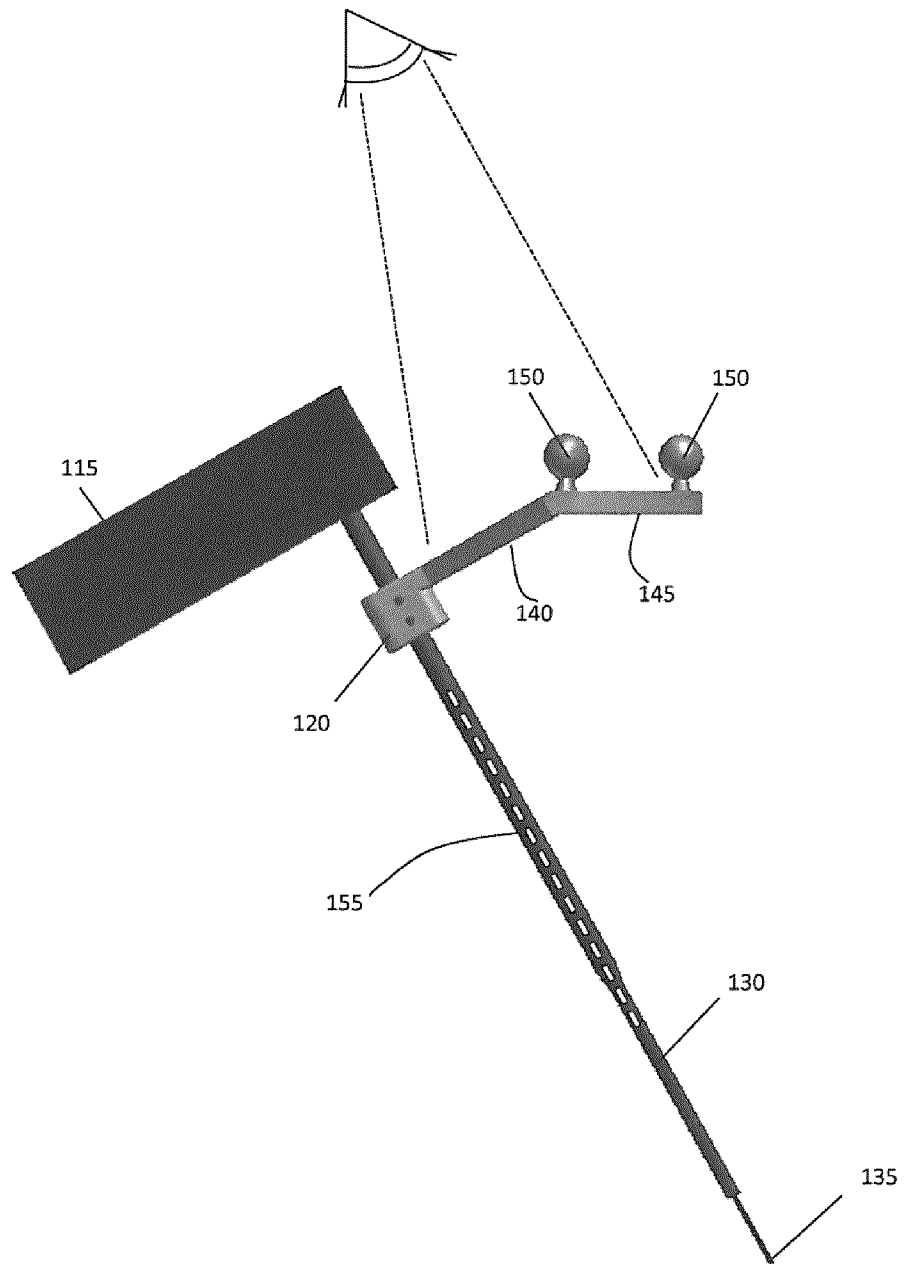

Figure 4

7/32

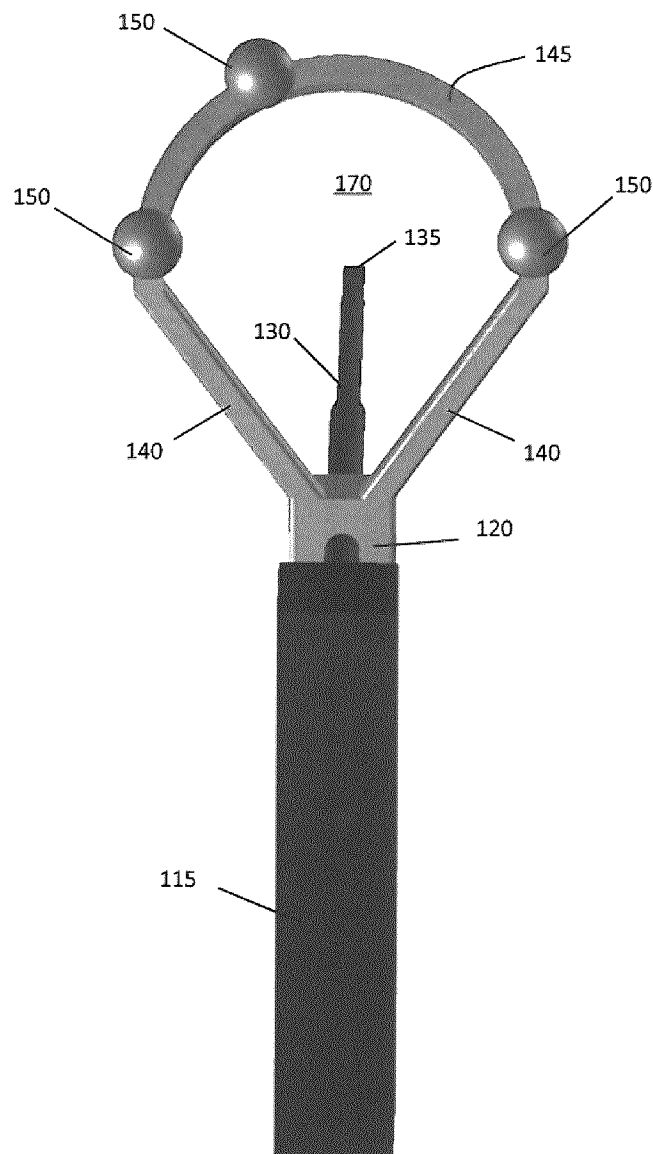

Figure 5(a)

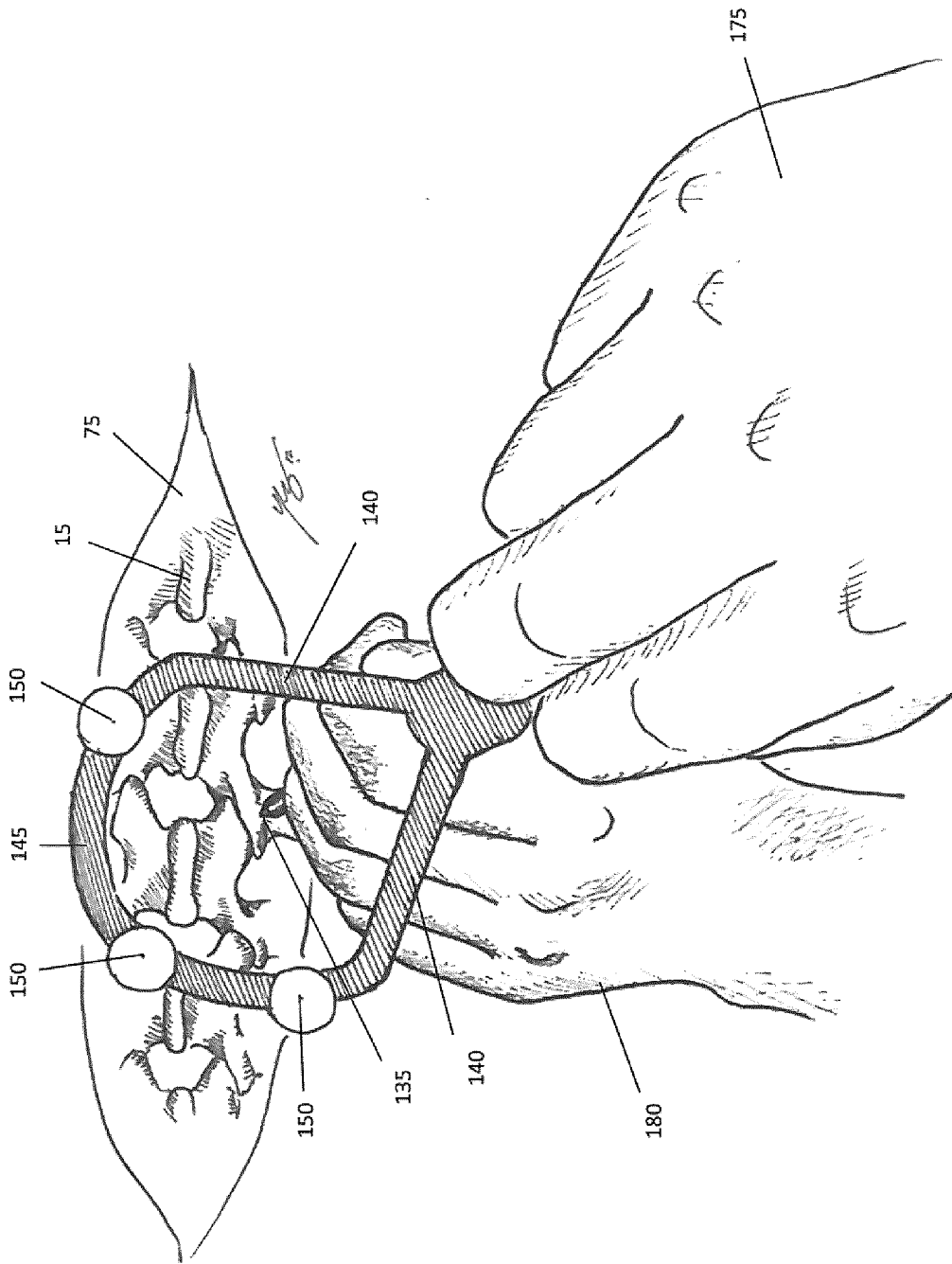
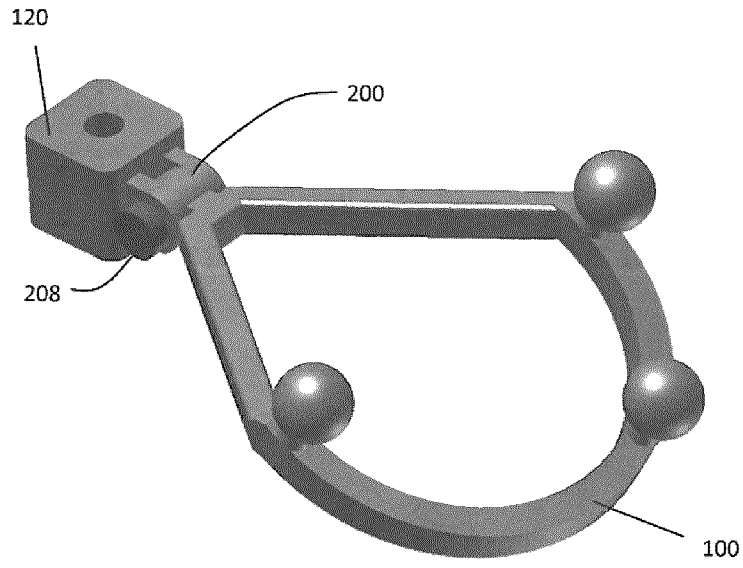
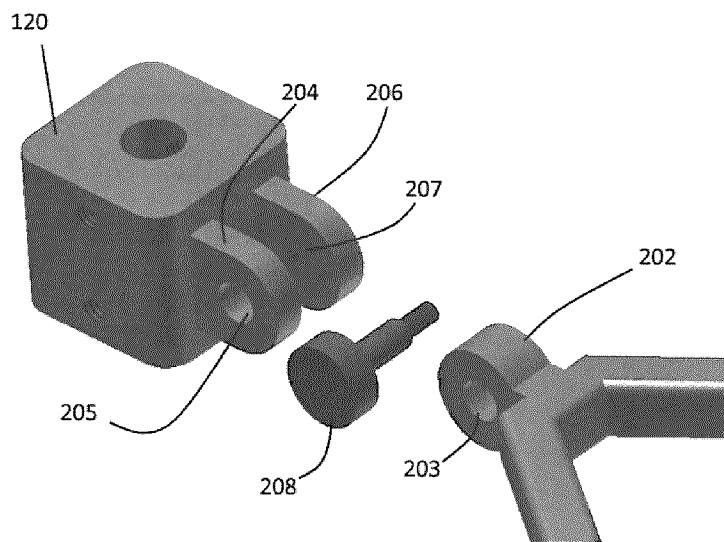

Figure 5(b)



(a)



(b)

Figure 6

10/32

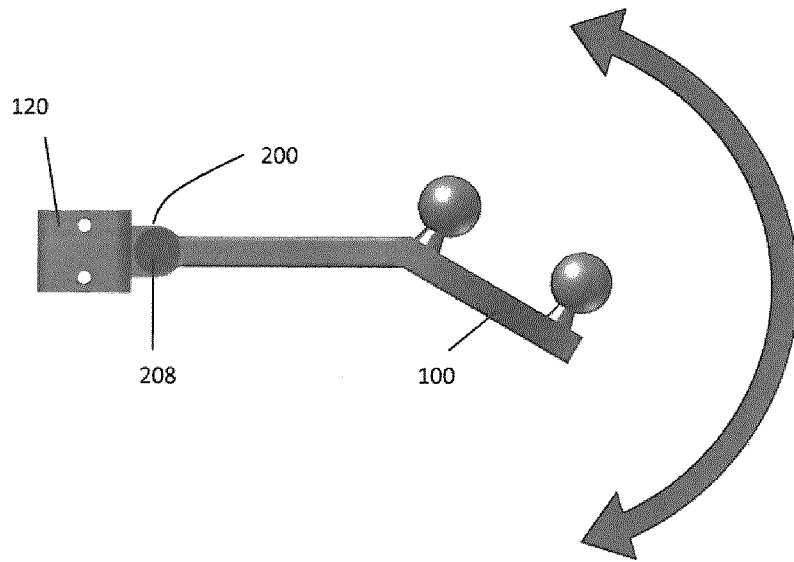
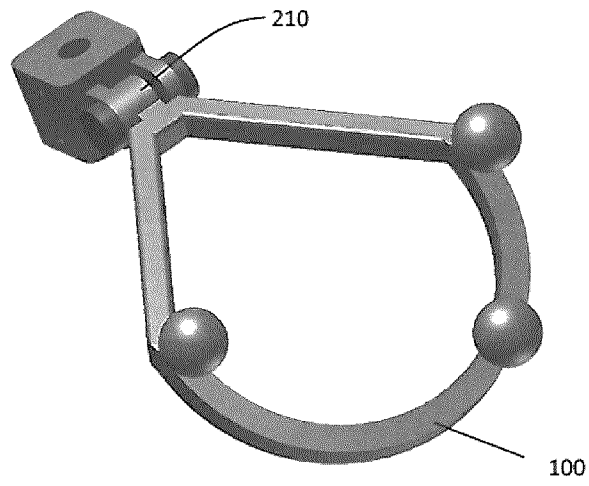
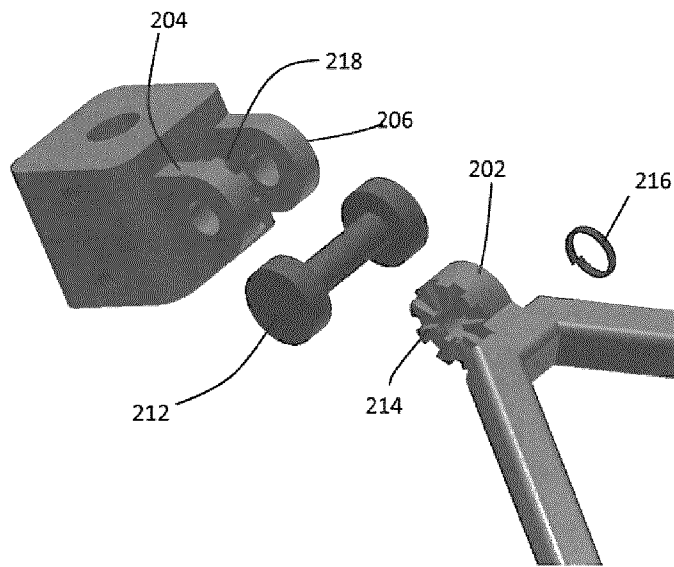

Figure 7



(a)



(b)

Figure 8

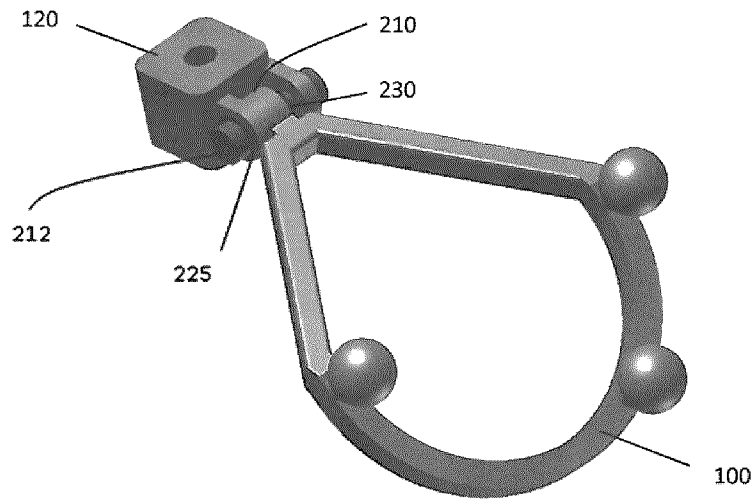

(a)

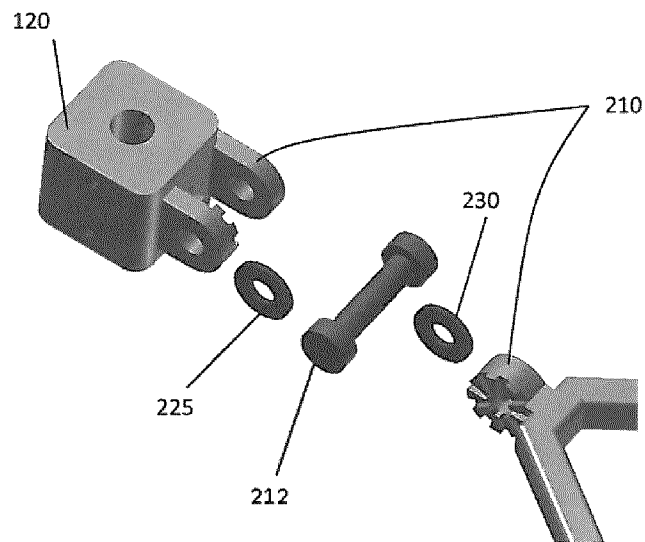

(b)

Figure 9

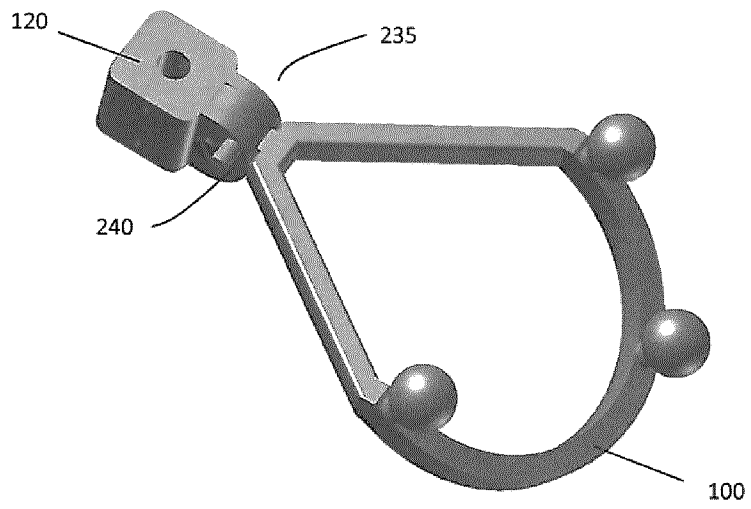

(a)

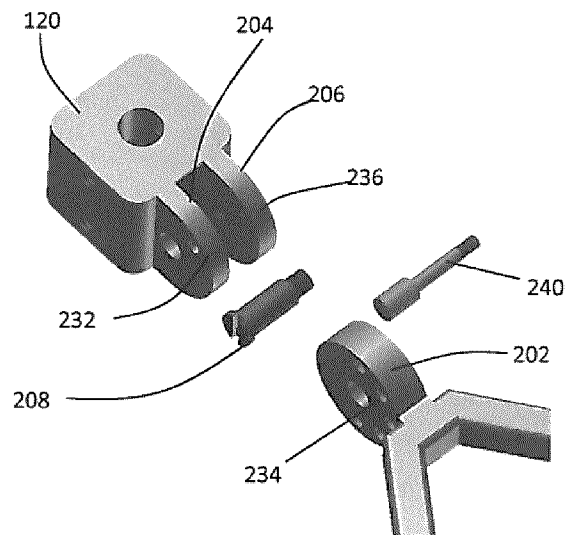

(b)

Figure 10

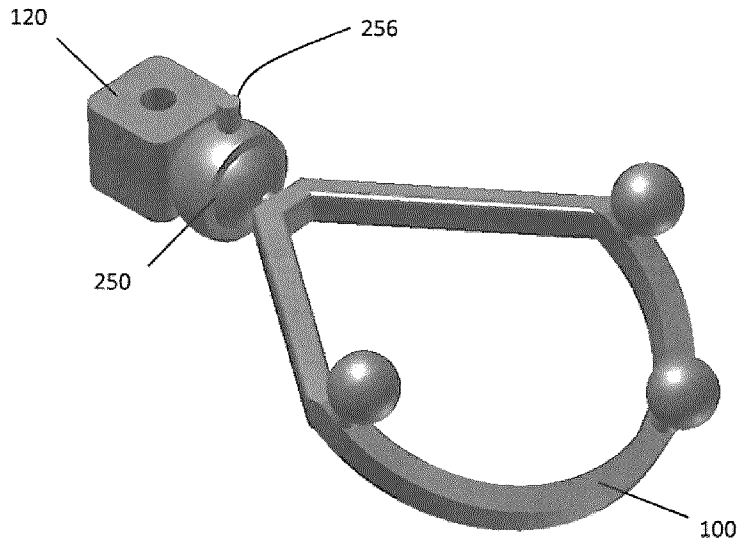

(a)

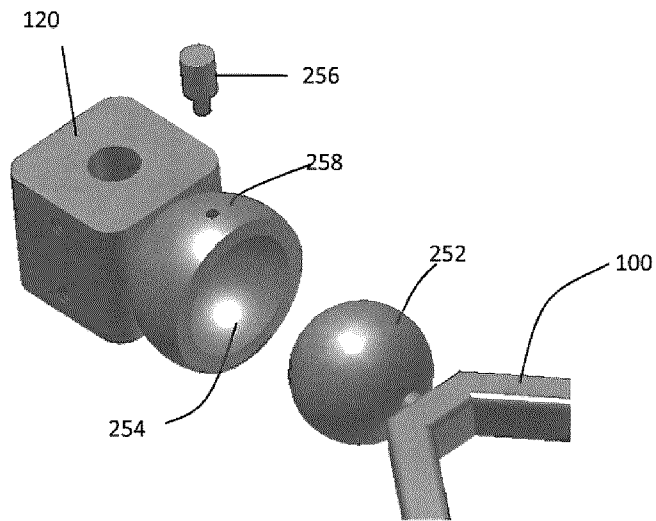

(b)

Figure 11

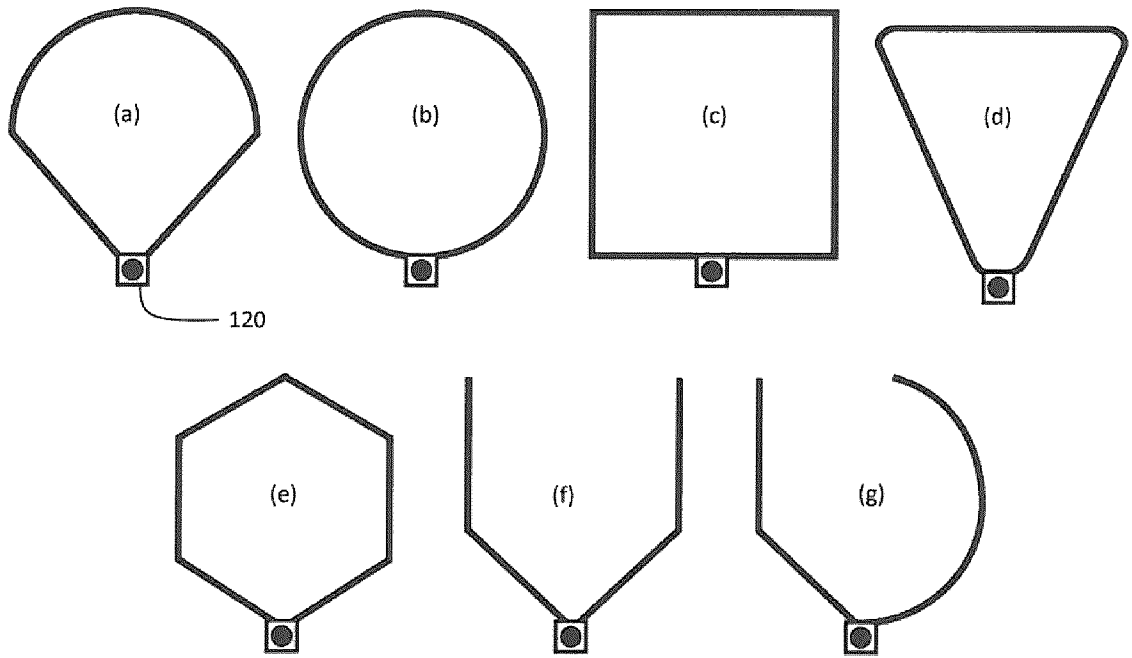

Figure 12

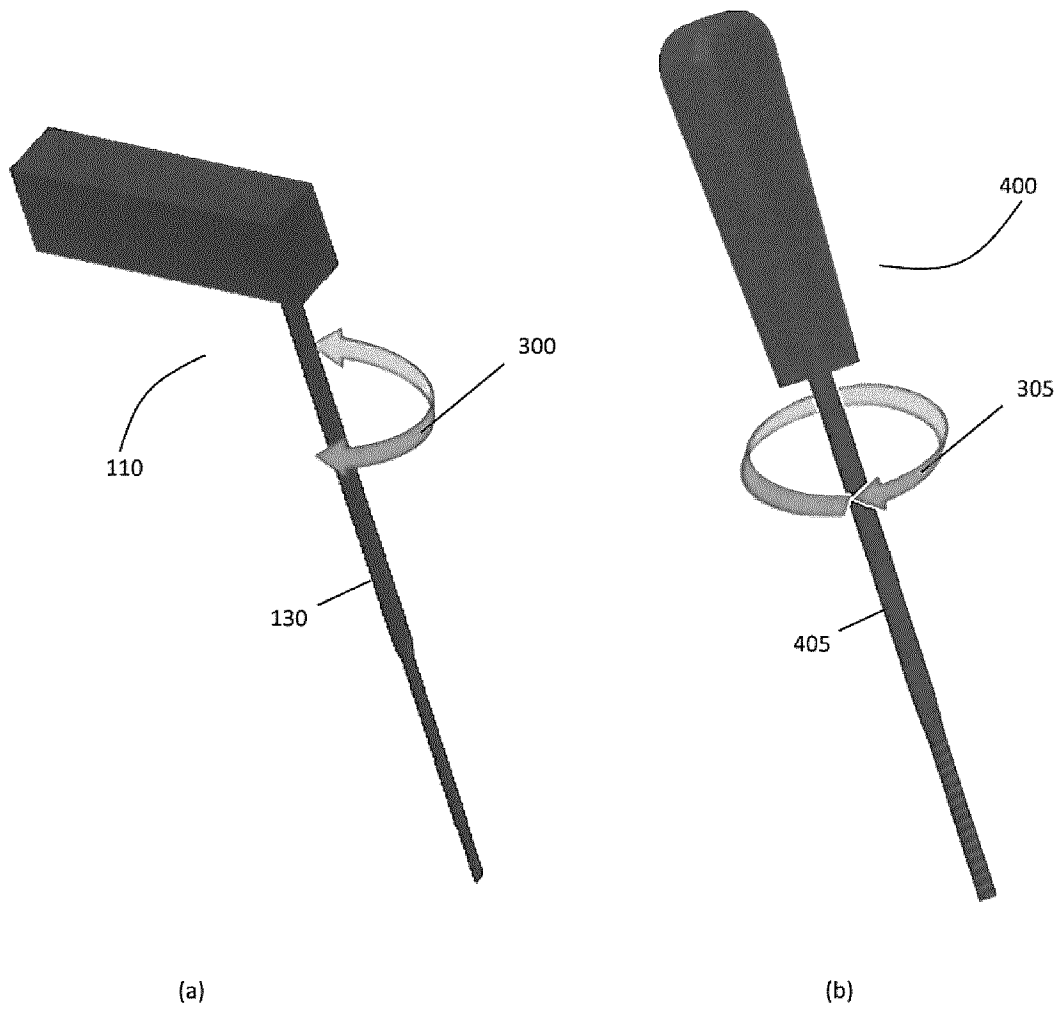
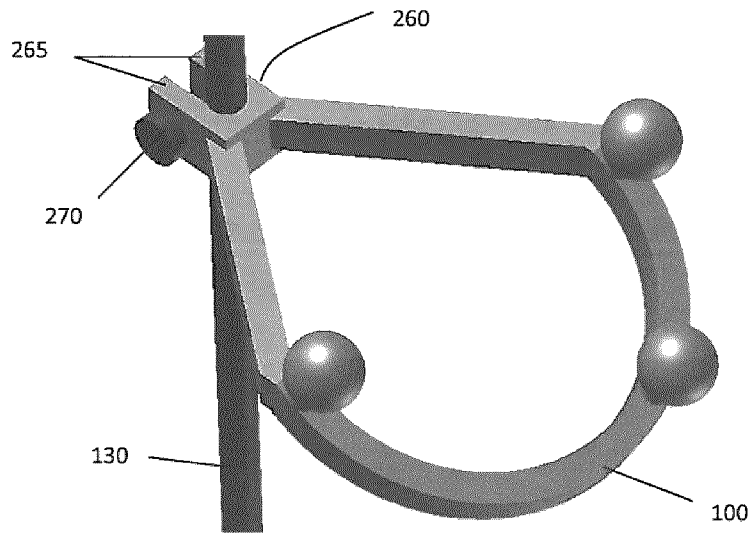
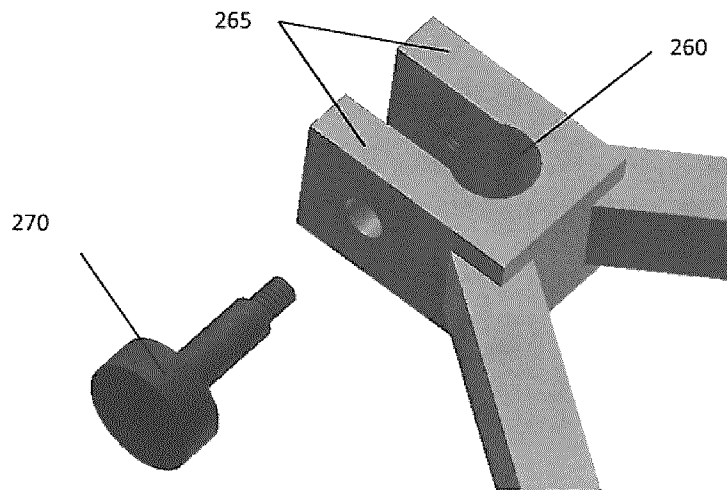

Figure 13

17/32



(a)



(b)

Figure 14

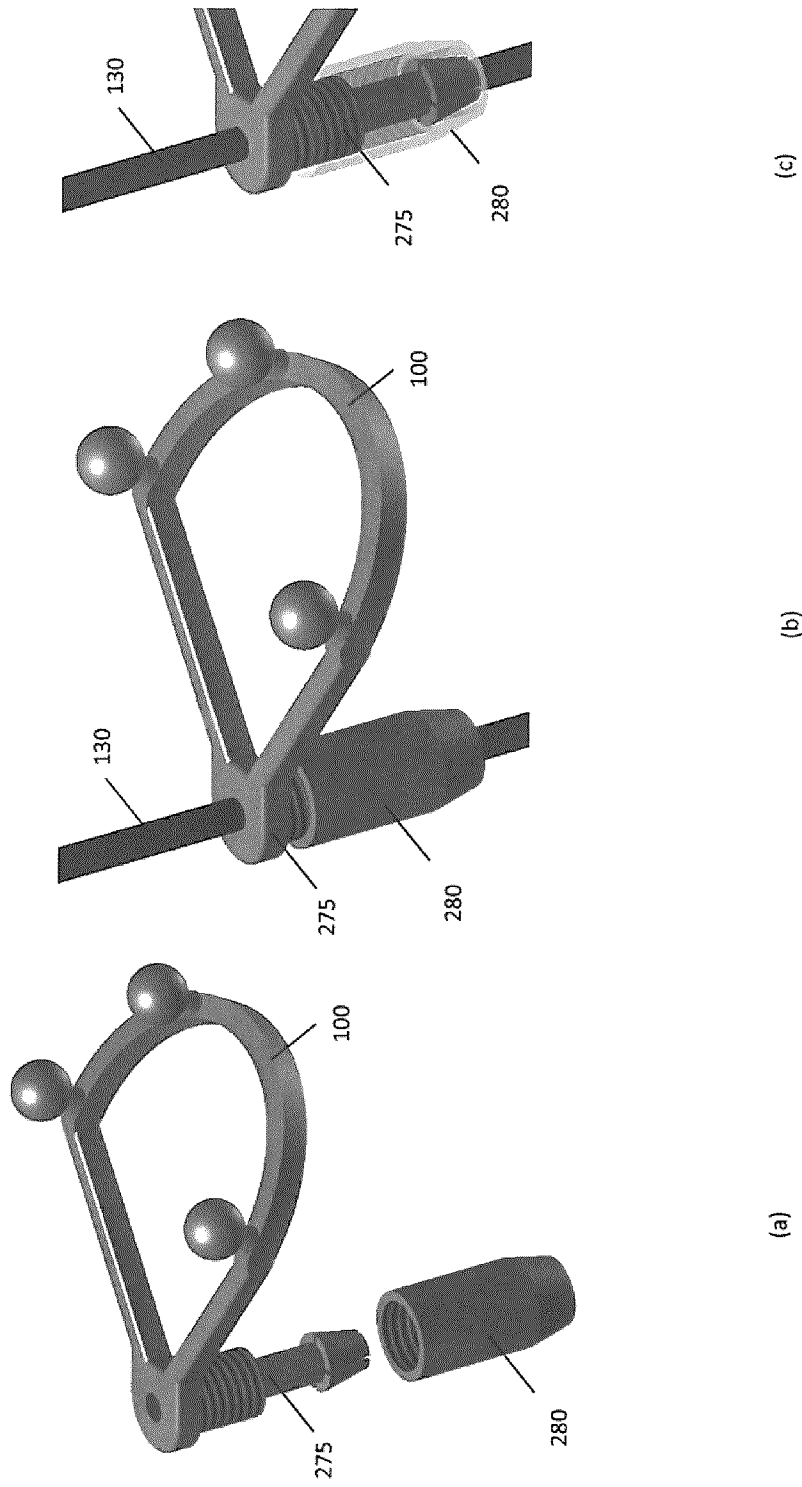

Figure 15

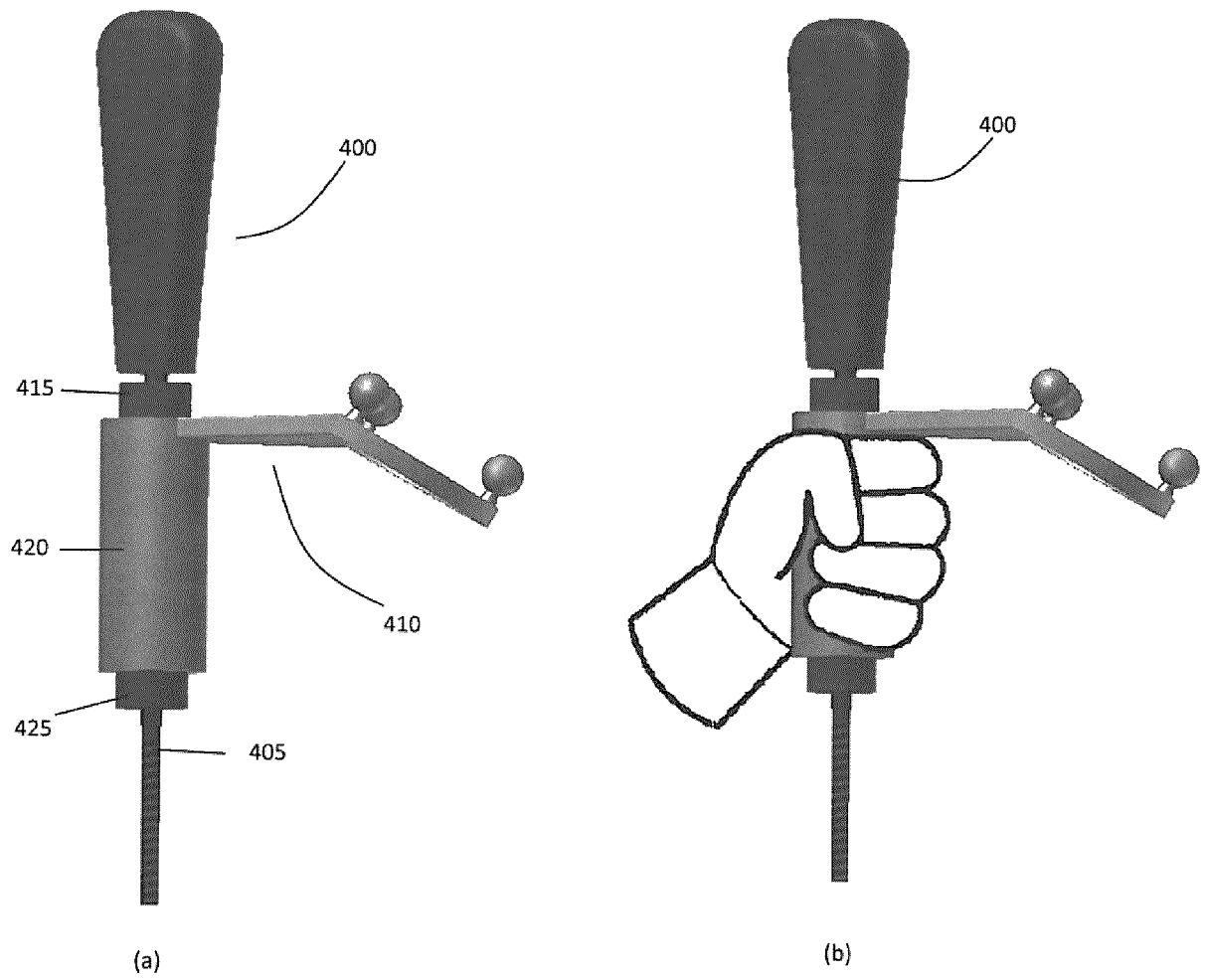

Figure 16

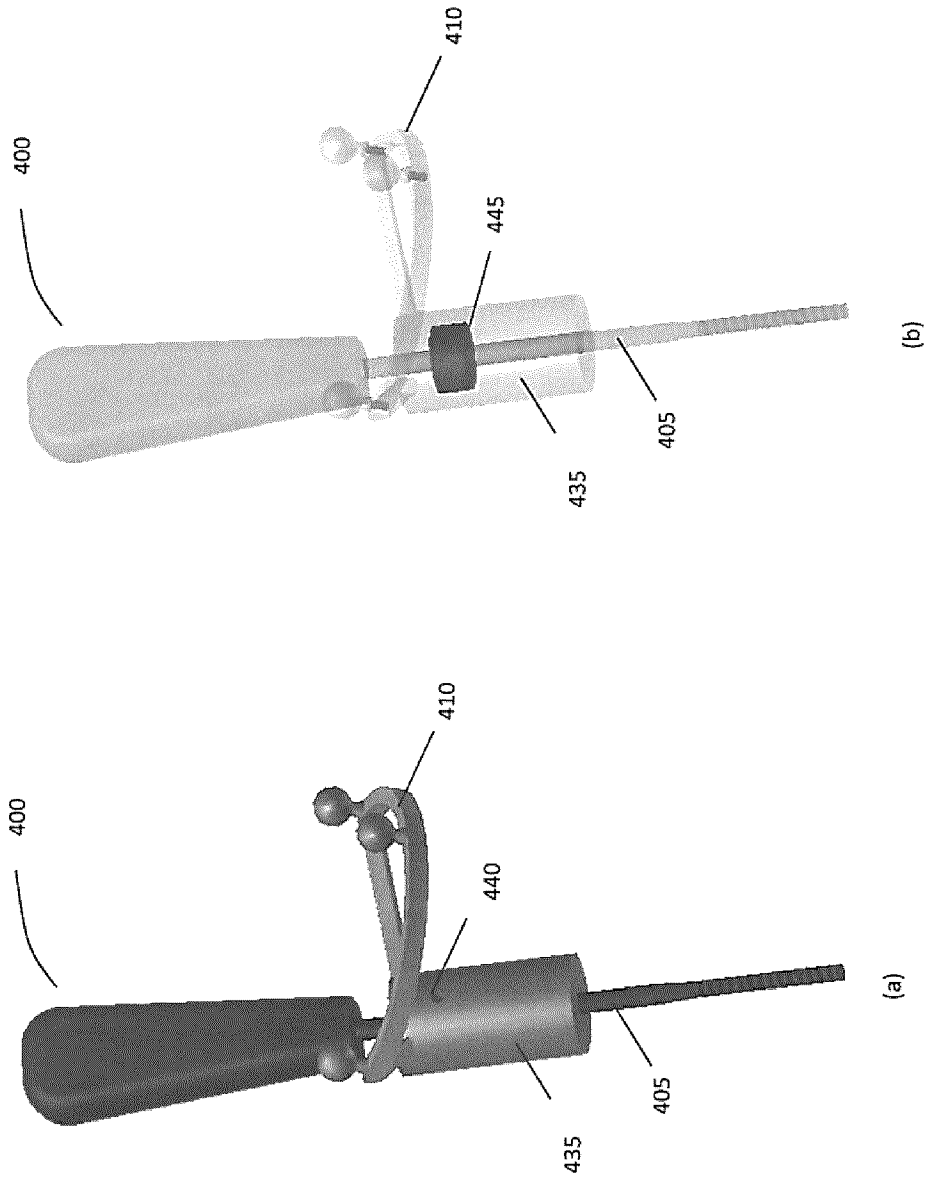

Figure 17

21/32

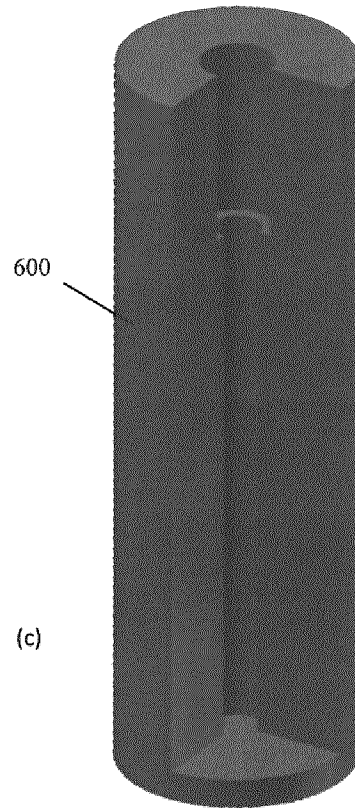
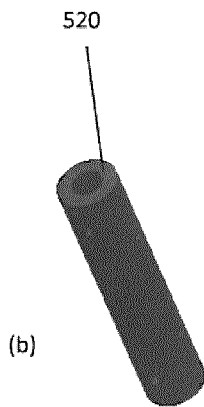
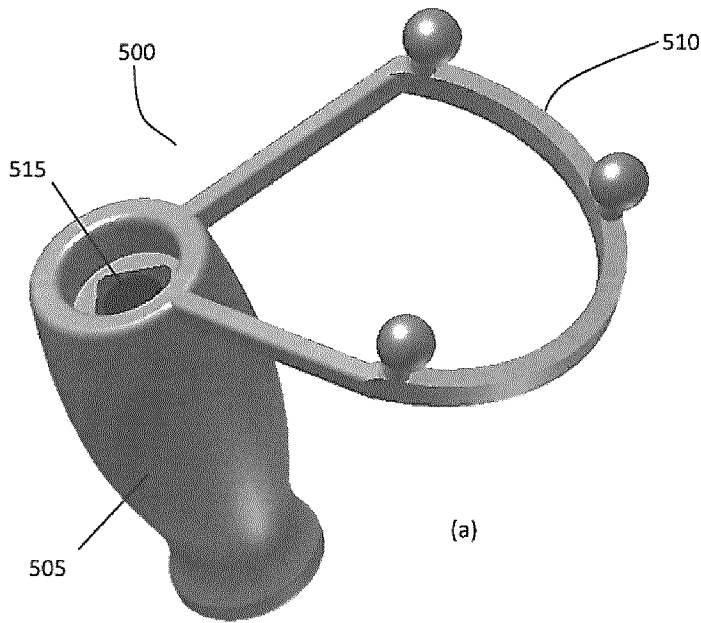

Figure 18

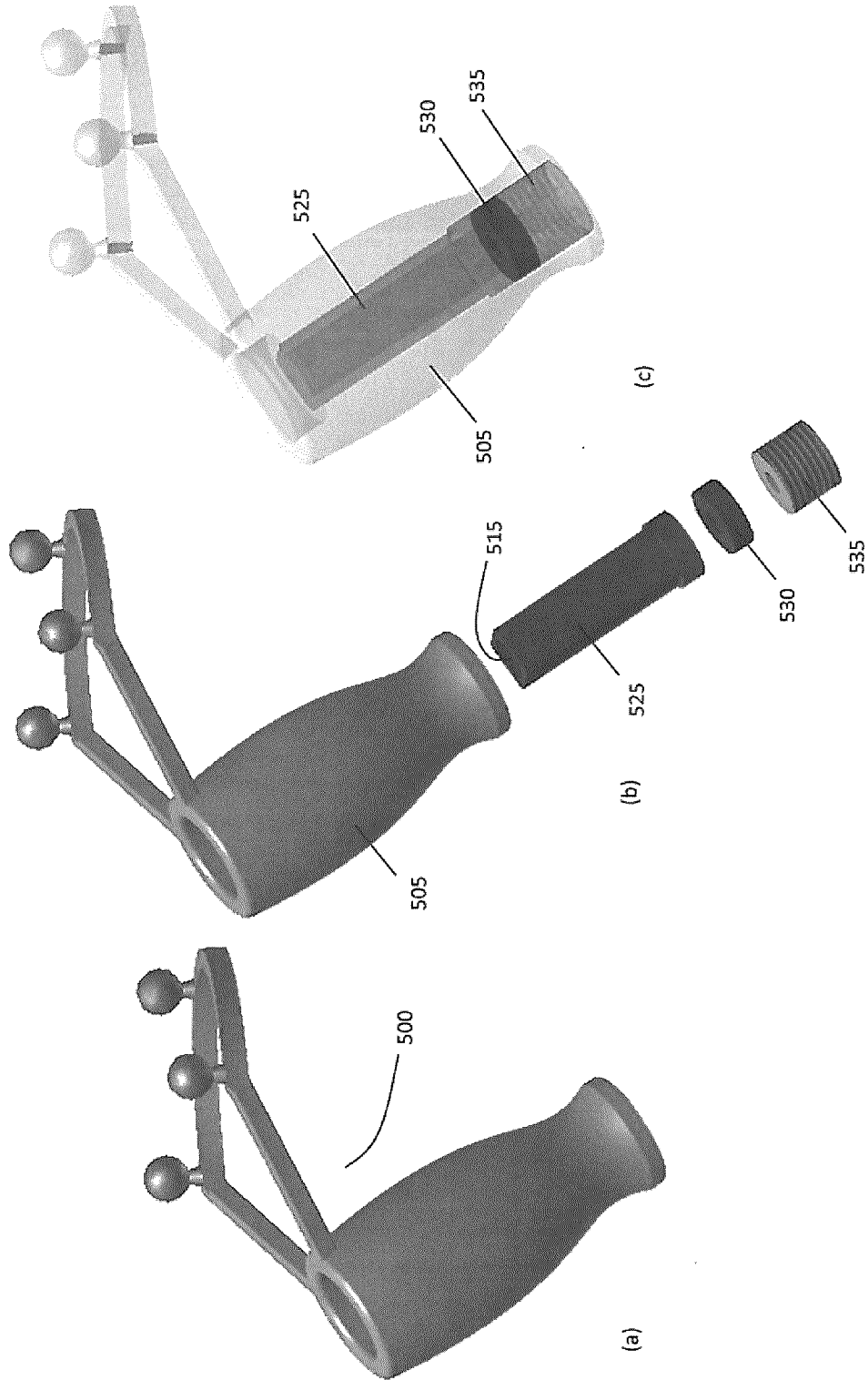

Figure 19

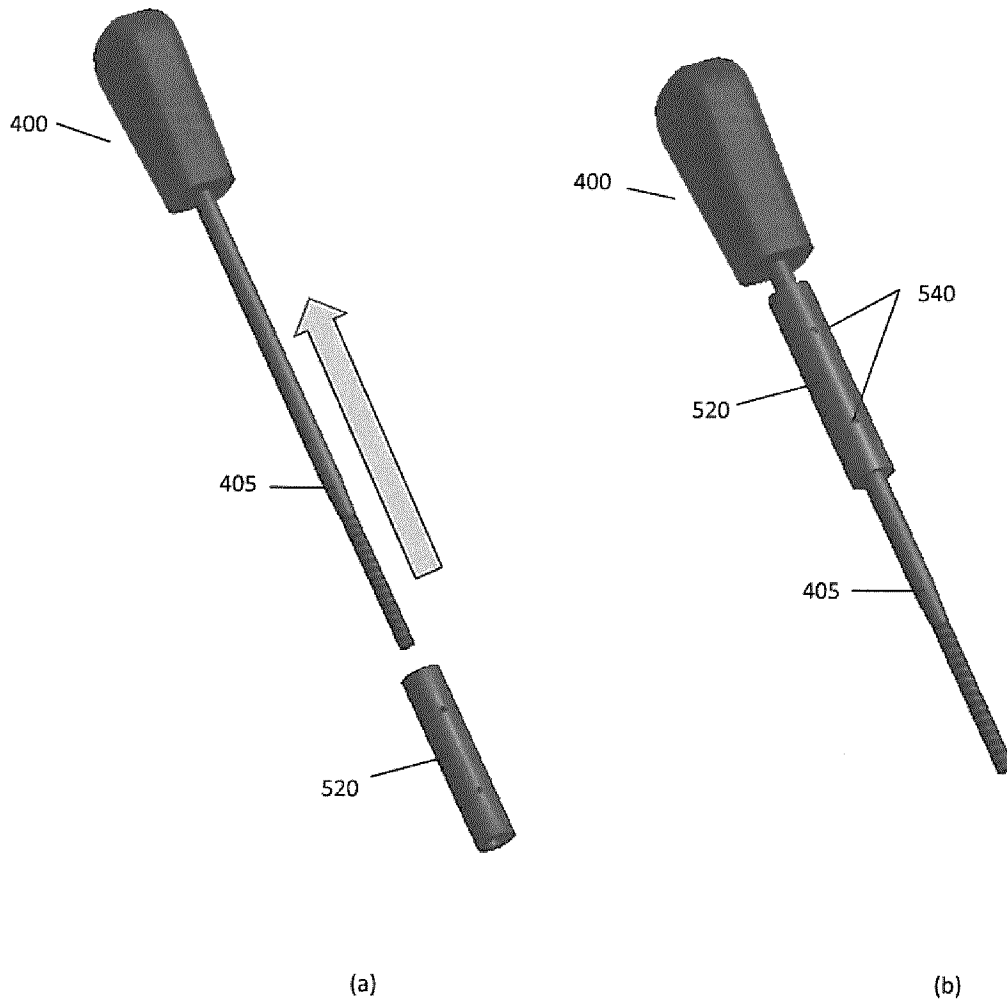

Figure 20

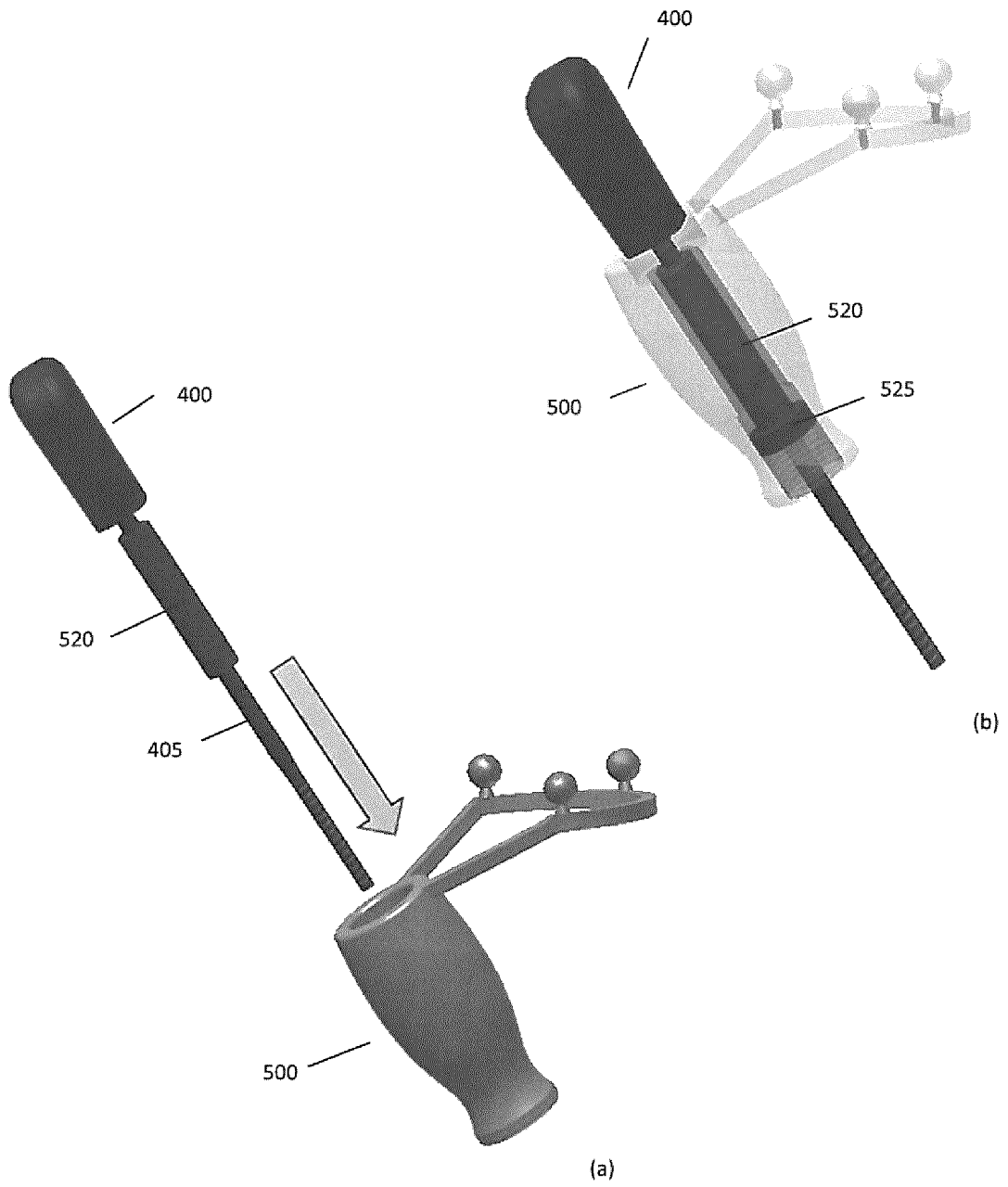

Figure 21

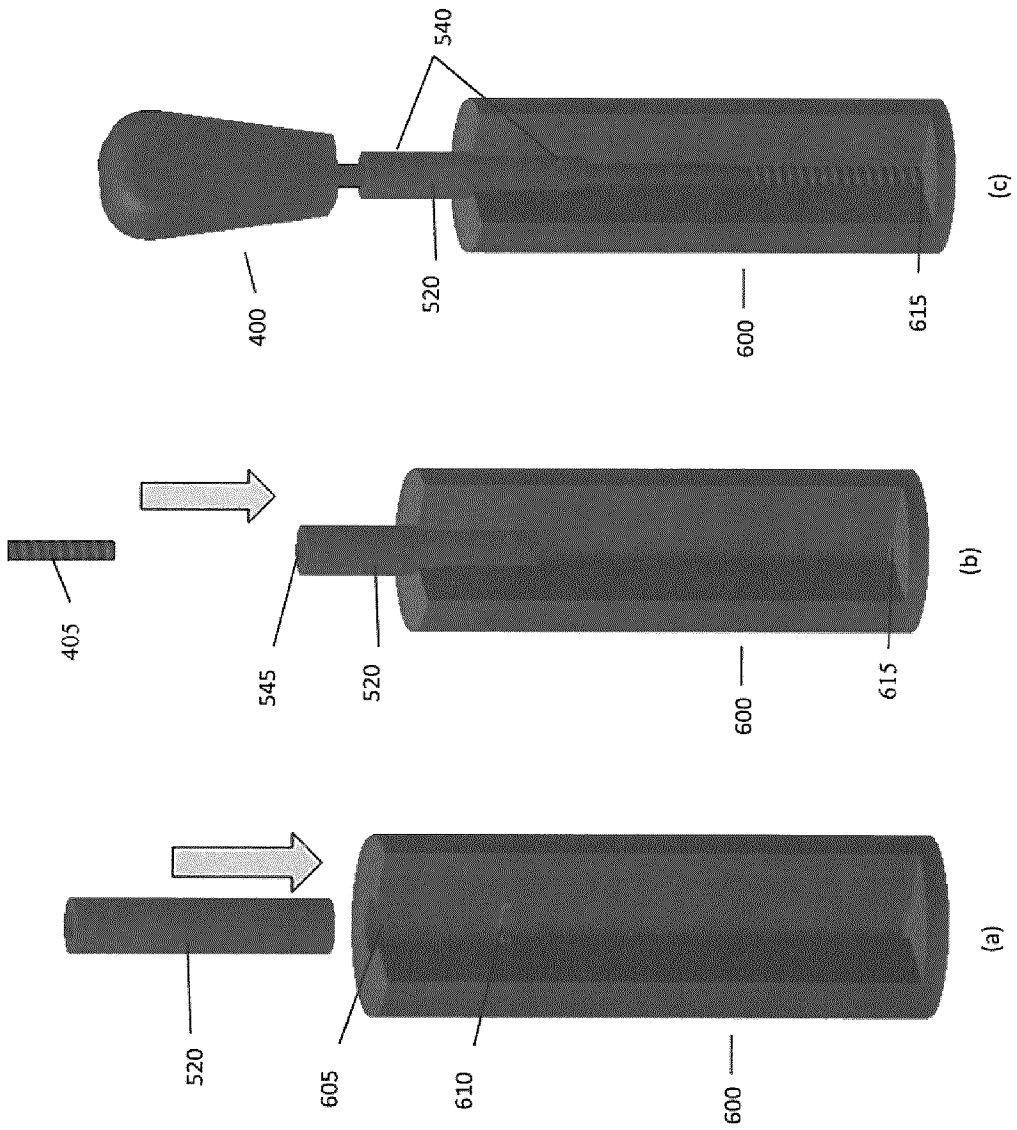

Figure 22

26/32

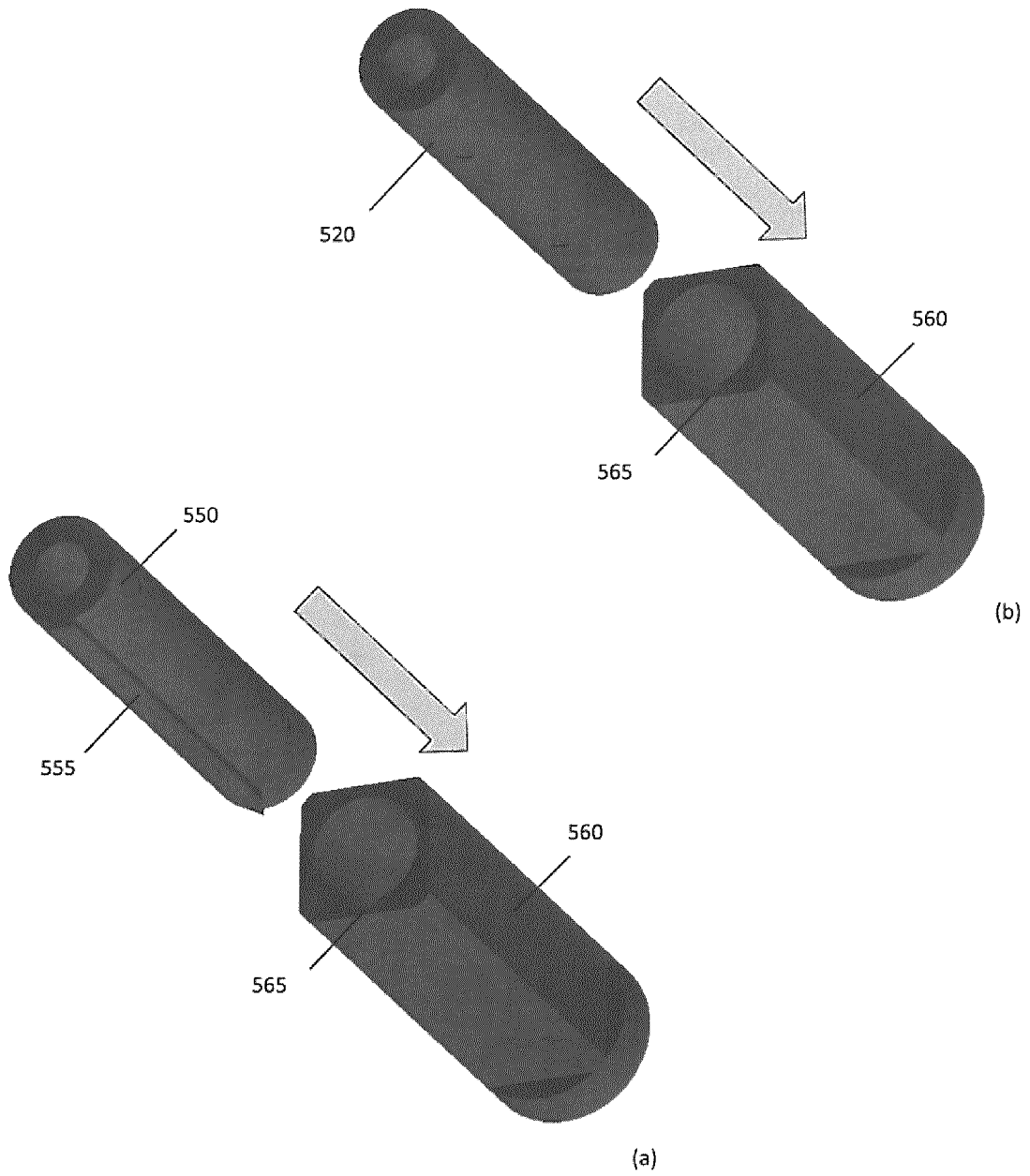

Figure 23

27/32

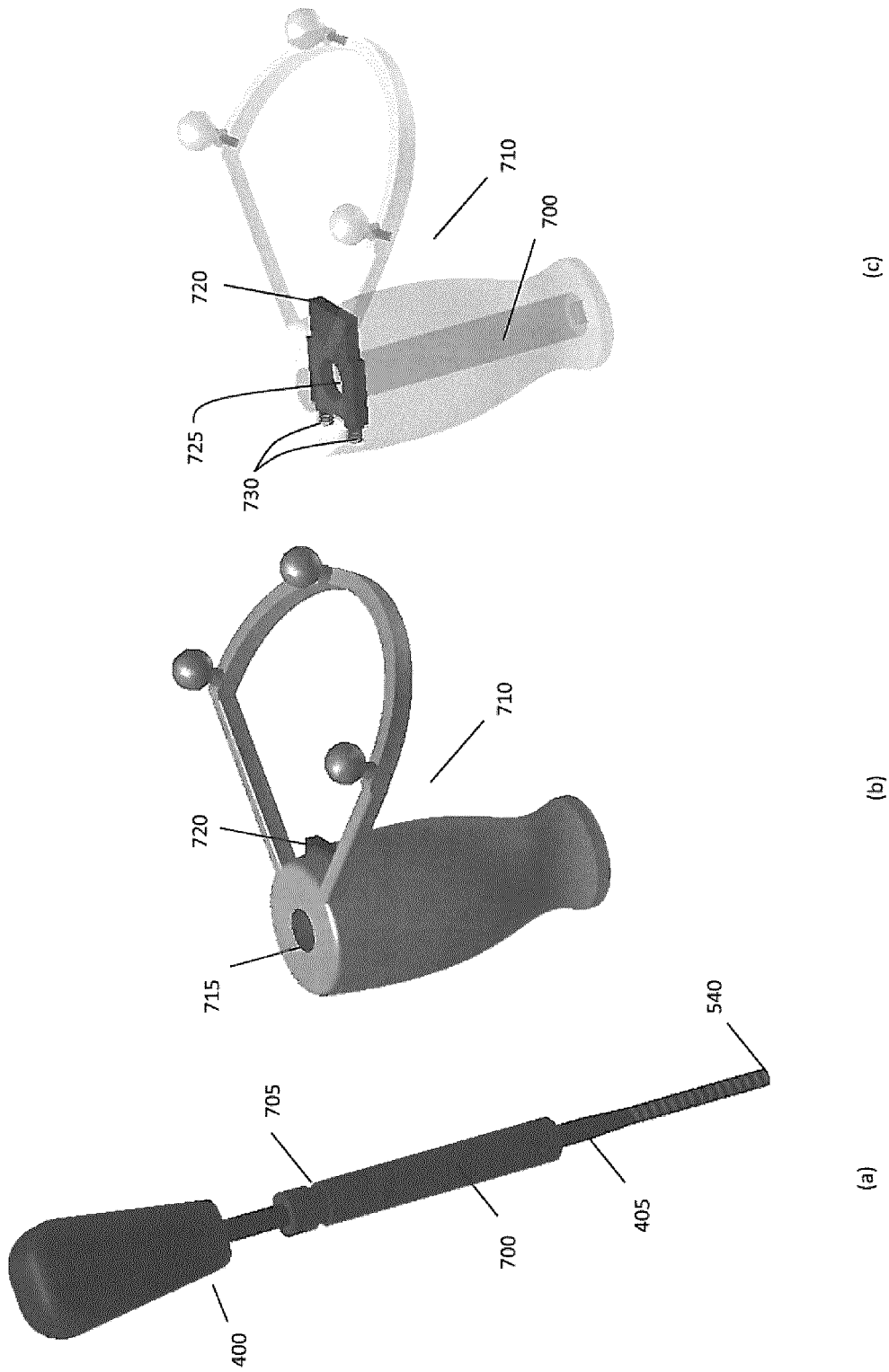

Figure 24

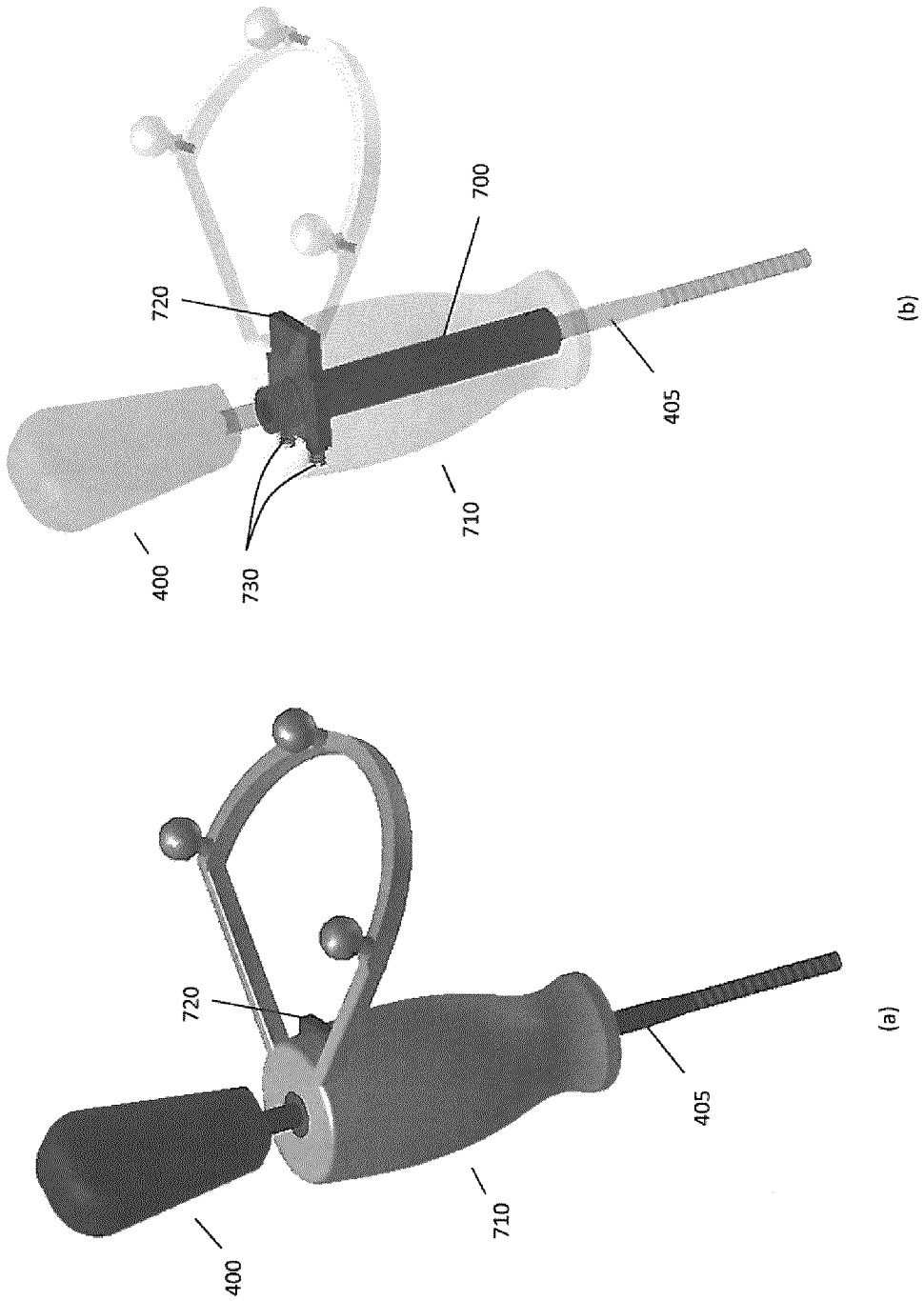

Figure 25

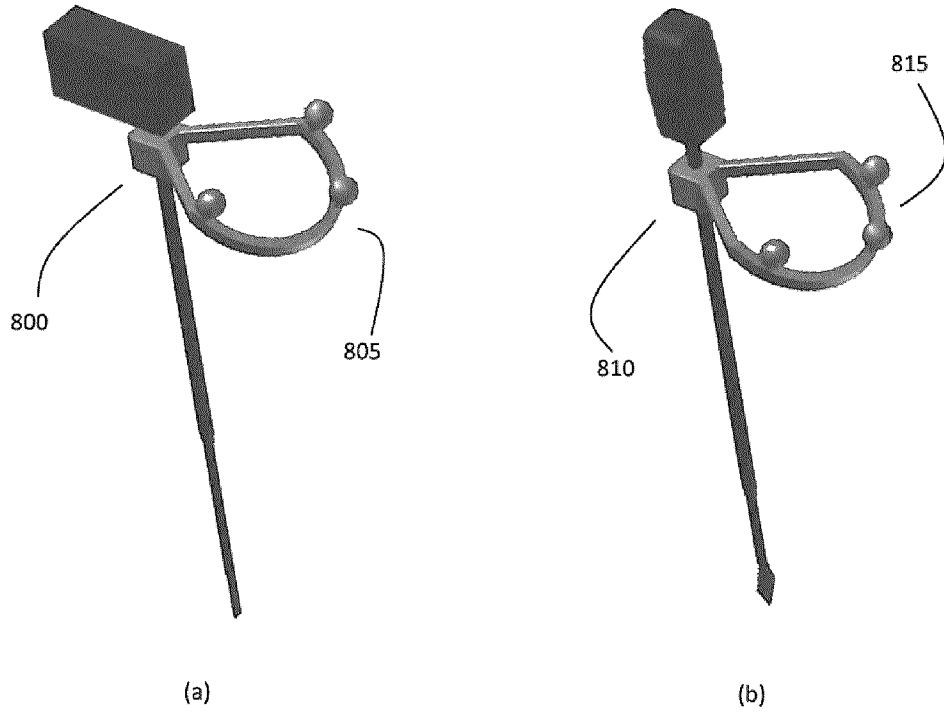

Figure 26

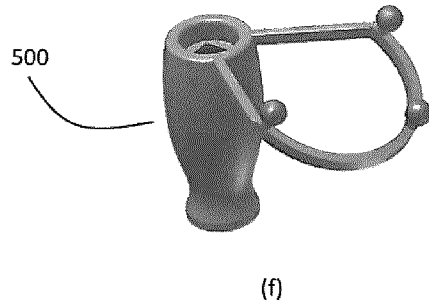
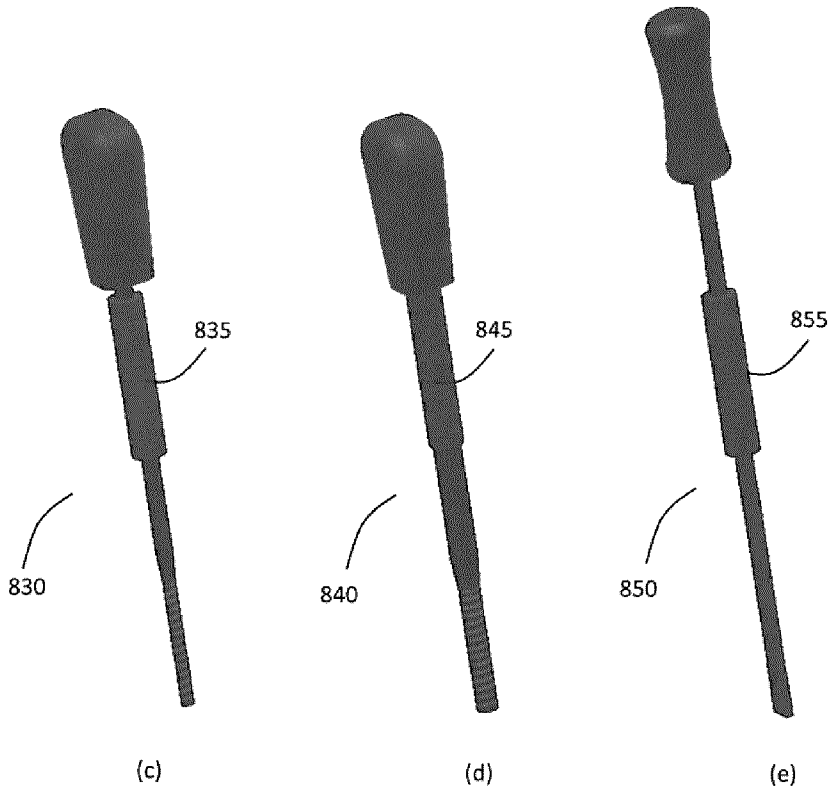

Figure 26 (Cont')

31/32

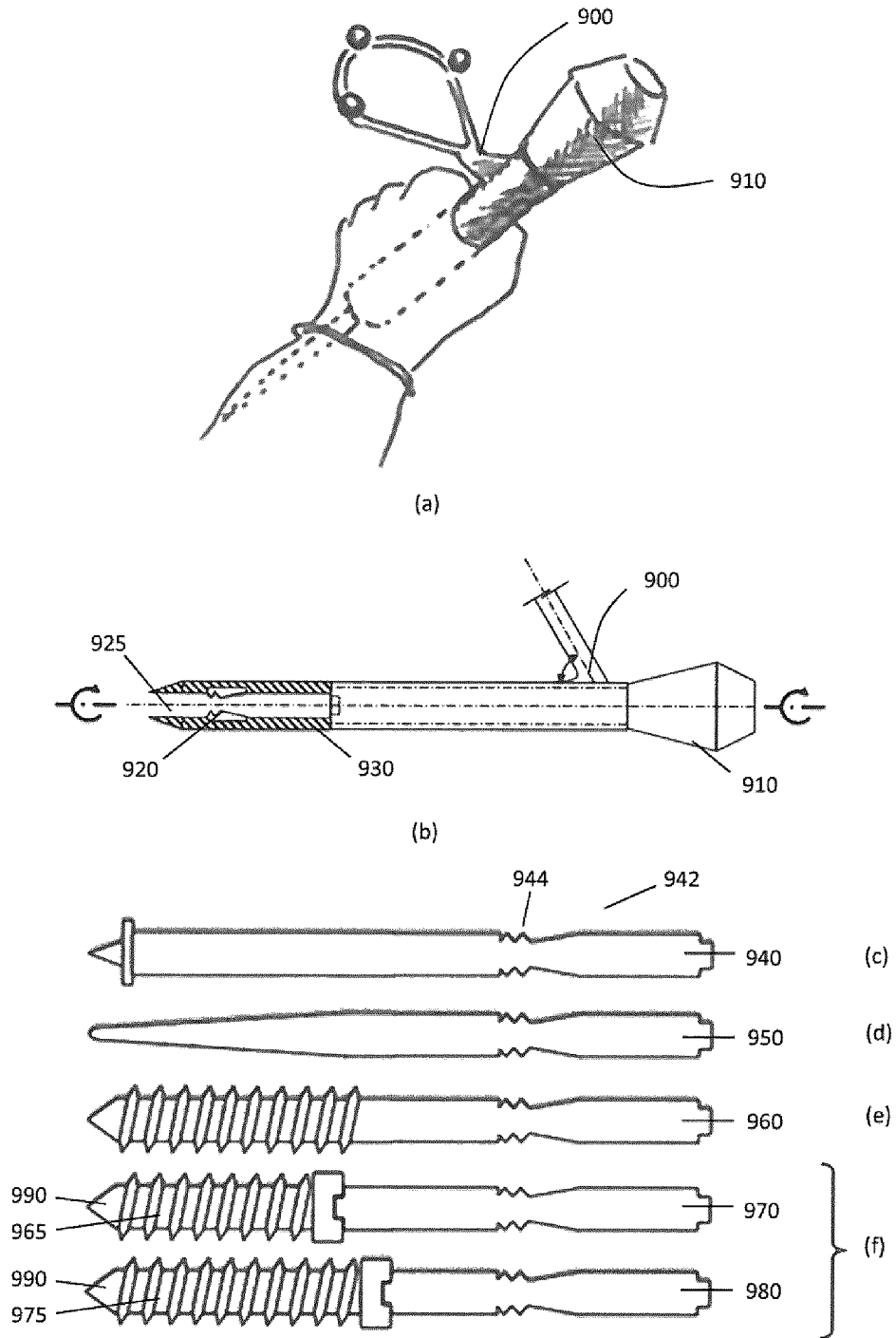

Figure 27

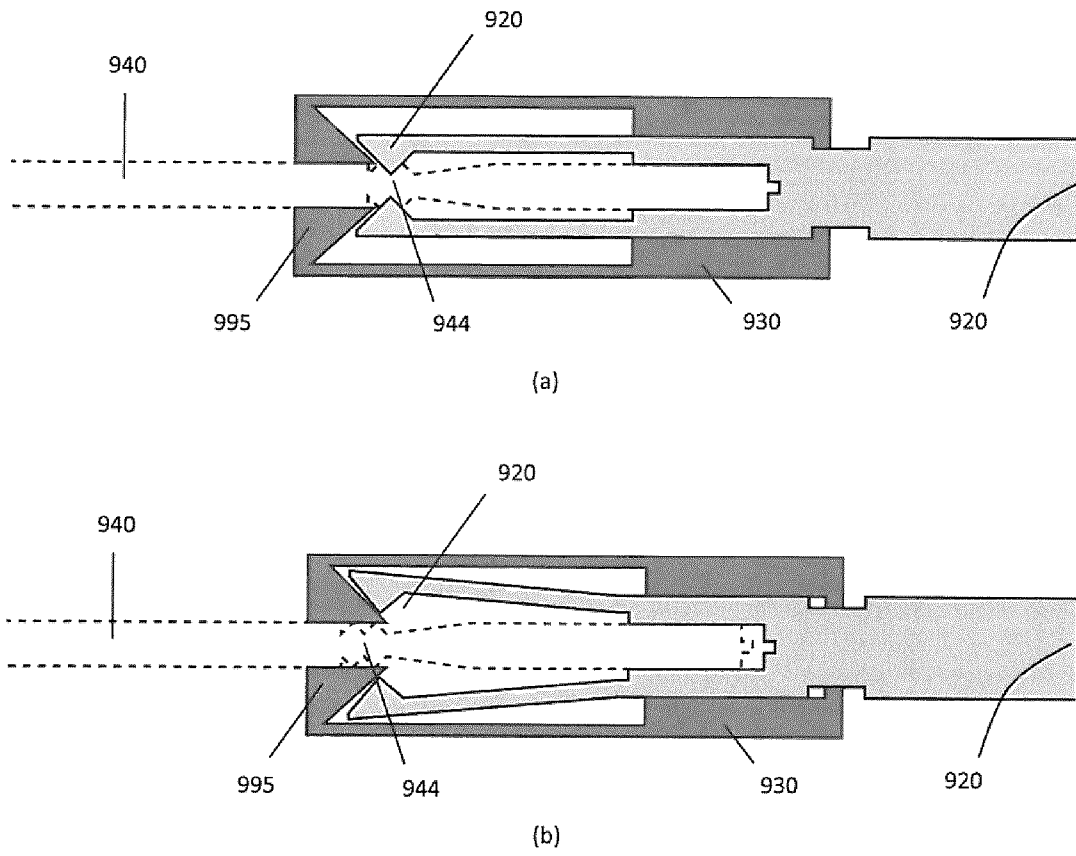

Figure 28

**INTERNATIONAL SEARCH REPORT**

International application No.  
PCT/CA2013/050512

A. CLASSIFICATION OF SUBJECT MATTER  
 IPC: **A61B 19/00** (2006.01) , **A61B 17/70** (2006.01) , **A61B 17/88** (2006.01) , **A61B 5/06** (2006.01)  
 According to International Patent Classification (IPC) or to both national classification and IPC

B. FIELDS SEARCHED  
 Minimum documentation searched (classification system followed by classification symbols)  
 IPC: A61B19/00; A61B17/70; A61B17/88; A61B5/06  
 CPC: A61B19/00; A61B17/70; A61B17/88; A61B5/06; A61B19/22; A61B19/52; A61B19/5225; A61B19/5244; A61B19/54  
 USPC: 600/407; 600/414; 600/424; 600/425; 600/426; 600/429; 600/431; 606/1; 606/130; 128/897; 128/898  
 Documentation searched other than minimum documentation to the extent that such documents are included in the fields searched

Electronic database(s) consulted during the international search (name of database(s) and, where practicable, search terms used)  
 Databases: Canadian Patent Database, EPODOC  
 Keywords: instrument/device/tool/implement/prob; track/follow/locat; optic; mark/fiduci/element/target/spher; plane; surgery/surgic

C. DOCUMENTS CONSIDERED TO BE RELEVANT

Category*	Citation of document, with indication, where appropriate, of the relevant passages	Relevant to claim No.
X Y	EP 1415609 A1 (COSMAN) 06 May 2004 (06-05-2004) *Fig. 1-4C; col. 5, paragraph [0014], col. 12, paragraph [0039]; claims 8 & 10*	1-12, 14, 19-20, 35-38, 46 13, 15-18
X Y	EP 1518508 A1 (HARMON et al.) 30 March 2005 (30-03-2005) *Fig. 1-6; col. 3, paragraph [0011], col. 4-5, paragraph [0015], col. 5-6, paragraph [0017], col. 6, paragraph [0019]*	1, 6-10, 14, 19-20, 35-38, 46 13, 15-18
X, P	US 2013/060278 A1 (BOZUNG et al.) 07 March 2013 (07-03-2013) *Fig. 1, 2-8, 18-23, 51-52, 55-56, 72-73; pg. 1, paragraph [0004], pg. 7, paragraph [00146], pg. 14, paragraph [0229] - pg. 15, paragraph [0236]*	1-6, 10, 13-18, 19-20, 35-38, 46
Y	US 6856828 B2 (COSSETTE et al.) 15 February 2005 (15-02-2005) *Fig. 1-2, 5a-5c; claim 1*	13, 15-18

Further documents are listed in the continuation of Box C.       See patent family annex.

* Special categories of cited documents :	"T" later document published after the international filing date or priority date and not in conflict with the application but cited to understand the principle or theory underlying the invention
"A" document defining the general state of the art which is not considered to be of particular relevance	"X" document of particular relevance; the claimed invention cannot be considered novel or cannot be considered to involve an inventive step when the document is taken alone
"E" earlier application or patent but published on or after the international filing date	"Y" document of particular relevance; the claimed invention cannot be considered to involve an inventive step when the document is combined with one or more other such documents, such combination being obvious to a person skilled in the art
"L" document which may throw doubts on priority claim(s) or which is cited to establish the publication date of another citation or other special reason (as specified)	"&" document member of the same patent family
"O" document referring to an oral disclosure, use, exhibition or other means	
"P" document published prior to the international filing date but later than the priority date claimed	

Date of the actual completion of the international search 24 October 2013 (24-10-2013)	Date of mailing of the international search report 13 November 2013 (13-11-2013)
Name and mailing address of the ISA/CA Canadian Intellectual Property Office Place du Portage I, C114 - 1st Floor, Box PCT 50 Victoria Street Gatineau, Quebec K1A 0C9 Facsimile No.: 001-819-953-2476	Authorized officer  <b>Andrew Pothier (819) 934-2577</b>

## INTERNATIONAL SEARCH REPORT

International application No.  
PCT/CA2013/050512

## C (Continuation). DOCUMENTS CONSIDERED TO BE RELEVANT

Category*	Citation of document, with indication, where appropriate, of the relevant passages	Relevant to claim No.
Y	US 2004/068263 A1 (CHOUINARD et al.) 08 April 2004 (08-04-2004) *Fig. 1-4; claim 1*	13, 15-18
A	US 7274958 B2 (JUTRAS et al.) 25 September 2007 (25-09-2007) *Fig. 1-4; 9-10; col. 6, lines 25-33*	1, 6, 19-20, 35, 38, 46
A	US 7166114 B2 (MOCTEZUMA DE LA BERRERA et al.) 23 January 2007 (23-01-2007) * Fig. 1, 7-14, 15-17; col. 6, lines 31-39*	1, 10, 13, 19-20, 35, 38, 46
A	US 7008430 B2 (DONG et al.) 07 March 2006 (07-03-2006) *Fig. 1-5, 8*	1-2, 4, 6, 15-17, 19-20, 35, 38, 46
A	US 2006/015018 A1 (JUTRAS et al.) 19 January 2006 (19-01-2006) * Fig. 1-2*	1, 10, 13, 15-17, 19-20, 35, 38, 46

**Box No. II Observations where certain claims were found unsearchable (Continuation of item 2 of the first sheet)**

This international search report has not been established in respect of certain claims under Article 17(2)(a) for the following reasons :

1.  Claim Nos. :  
because they relate to subject matter not required to be searched by this Authority, namely :
  
2.  Claim Nos. :  
because they relate to parts of the international application that do not comply with the prescribed requirements to such an extent that no meaningful international search can be carried out, specifically :
  
3.  Claim Nos. :  
because they are dependent claims and are not drafted in accordance with the second and third sentences of Rule 6.4(a).

**Box No. III Observations where unity of invention is lacking (Continuation of item 3 of first sheet)**

This International Searching Authority found multiple inventions in this international application, as follows :

The claims are directed to a plurality of inventive concepts as follows:

**Group A** - Claims **1-20, 35-38 & 46** are directed to a marker assembly for a handheld instrument comprising a plurality of tracking markers defining a marker plane, said marker plane not parallel to the longitudinal axis of a longitudinal portion of the handheld instrument.

- Continued on extra sheet

1.  As all required additional search fees were timely paid by the applicant, this international search report covers all searchable claims.
2.  As all searchable claims could be searched without effort justifying additional fees, this Authority did not invite payment of additional fees.
3.  As only some of the required additional search fees were timely paid by the applicant, this international search report covers only those claims for which fees were paid, specifically claim Nos. :
4.  No required additional search fees were timely paid by the applicant. Consequently, this international search report is restricted to the invention first mentioned in the claims; it is covered by claim Nos. : 1-20, 35-38, 46

- Remark on Protest**  The additional search fees were accompanied by the applicant's protest and, where applicable, the payment of a protest fee.
- The additional search fees were accompanied by the applicant's protest but the applicable protest fee was not paid within the time limit specified in the invitation.
- No protest accompanied the payment of additional search fees.

Continuation of: Box No. III

**Group B** - Claims **21-34 & 47** are directed to an interchangeable marker assembly for a plurality of handheld instruments having a plurality of tracking markers forming a marker assembly, said markers attachable to the each of the handheld implements via a plurality of connection adapters.

**Group C** - Claims **39-45** are directed to a trackable tool system comprising a plurality of exchangeable tool extensions attachable to a handheld body having a plurality of tracking markers.

The claims must be limited to one inventive concept as set out in **Rule 13 of the PCT**.

**INTERNATIONAL SEARCH REPORT**  
Information on patent family members

International application No.  
**PCT/CA2013/050512**

Patent Document Cited in Search Report	Publication Date	Patent Family Member(s)	Publication Date
EP1415609A1	06 May 2004 (06-05-2004)	AU1800999A AU5002497A CA2318252A1 DE69833881T2 EP1041918B1 ES2256974T3 US6275725B1 US6405072B1 WO9927839A3 WO9927839A9 WO9938449A1	16 June 1999 (16-06-1999) 15 May 1998 (15-05-1998) 05 August 1999 (05-08-1999) 07 December 2006 (07-12-2006) 15 March 2006 (15-03-2006) 16 July 2006 (16-07-2006) 14 August 2001 (14-08-2001) 11 June 2002 (11-06-2002) 10 September 1999 (10-09-1999) 21 October 1999 (21-10-1999) 05 August 1999 (05-08-1999)
EP1518508A1	30 March 2005 (30-03-2005)	AU2004205314A1 CA2476047A1 JP2005066345A US2005049485A1	17 March 2005 (17-03-2005) 27 February 2005 (27-02-2005) 17 March 2005 (17-03-2005) 03 March 2005 (03-03-2005)
US2013060278A1	07 March 2013 (07-03-2013)	US2013060278A1 WO2013033566A1	07 March 2013 (07-03-2013) 07 March 2013 (07-03-2013)
US6856828B2	15 February 2005 (15-02-2005)	AU2003273690A1 EP1562510A1 US2004068260A1 WO2004030557A1	23 April 2004 (23-04-2004) 17 August 2005 (17-08-2005) 08 April 2004 (08-04-2004) 15 April 2004 (15-04-2004)
US2004068263A1	08 April 2004 (08-04-2004)	AU2003273691A1 WO2004030558A1	23 April 2004 (23-04-2004) 15 April 2004 (15-04-2004)
US7274958B2	25 September 2007 (25-09-2007)	AT413849T AU2003269657A1 DE60324691D1 EP1545366B1 EP1913891A1 US2004068179A1 WO2004030555A1	15 November 2008 (15-11-2008) 23 April 2004 (23-04-2004) 24 December 2008 (24-12-2008) 12 November 2008 (12-11-2008) 23 April 2008 (23-04-2008) 08 April 2004 (08-04-2004) 15 April 2004 (15-04-2004)
US7166114B2	23 January 2007 (23-01-2007)	DE10340434A1 DE102007059690A1 US2007173790A1 US2007175489A1	01 April 2004 (01-04-2004) 10 July 2008 (10-07-2008) 26 July 2007 (26-07-2007) 02 August 2007 (02-08-2007)
US7008430B2	07 March 2006 (07-03-2006)	AT320230T DE602004000479D1 EP1442729A1 EP1442729B1 US2004153080A1	15 April 2006 (15-04-2006) 11 May 2006 (11-05-2006) 04 August 2004 (04-08-2004) 15 March 2006 (15-03-2006) 05 August 2004 (05-08-2004)
US2006015018A1	19 January 2006 (19-01-2006)	EP1615577A2 WO2004069073A2 WO2004069073A3	18 January 2006 (18-01-2006) 19 August 2004 (19-08-2004) 18 November 2004 (18-11-2004)