

June 3, 1930.

G. W. LAMPMAN
VALVE SPRING RETAINER
Filed March 26, 1928

1,761,925

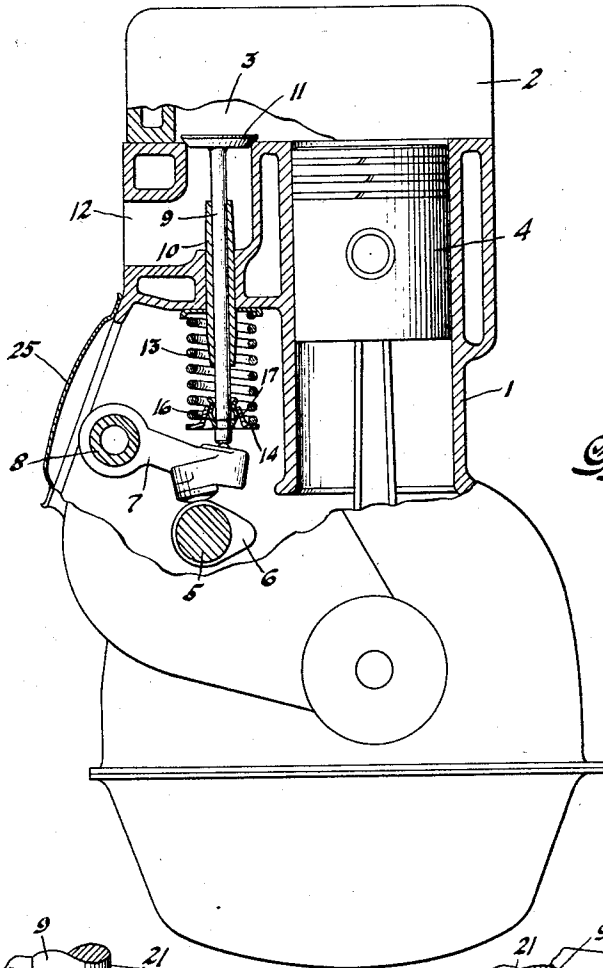

Fig. 1

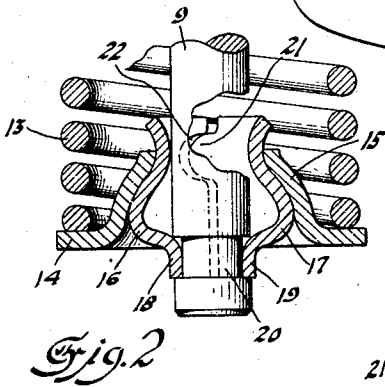

Fig. 2

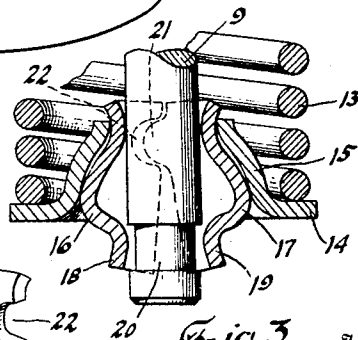

Fig. 3

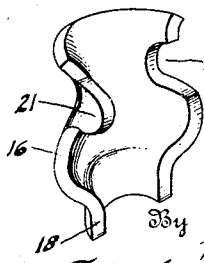

Fig. 4

Inventor

George W. Lampman

Blackmore, Spencer & Hunt
Attorneys

UNITED STATES PATENT OFFICE

GEORGE W. LAMPMAN, OF PONTIAC, MICHIGAN, ASSIGNOR TO GENERAL MOTORS CORPORATION, OF DETROIT, MICHIGAN, A CORPORATION OF DELAWARE

VALVE-SPRING RETAINER

Application filed March 26, 1928. Serial No. 264,868.

This invention relates to internal combustion engines and more particularly to a connection between a poppet valve and the tension spring that normally maintains the valve on its seat.

It is an object of the invention to provide an improved connection which may be readily and quickly detached from the valve stem to allow removal of the valve from the engine by the use of a suitable tool manipulated entirely from outside the engine in order that the operator will not be called upon to insert his hands or fingers in the more or less inaccessible places and where the space in which to work is limited.

Another object of the invention is to provide a detachable spring retainer comprising a number of parts that are held together in a unitary assembly so as to prevent displacement or a loss of the parts during such times when the valve is removed.

A further object of the invention is to provide a detachable spring retainer in which the parts are rockable into and out of engagement with the stem and in which there is present a wedging action on the parts under the influence of the tension of the valve spring whereby there will be no likelihood of accidental disengagement from the stem.

A further object is to provide a collar against which the spring bears and which is movable axially of the rockable parts for contact with inclined surfaces thereof to swing such parts into and out of engagement with the valve stem.

Other objects and advantages will be apparent from the following specification taken in connection with the accompanying drawing, wherein,—

Fig. 1 is an end elevation of an internal combustion engine, with parts broken away and shown in section, illustrating the application of the present invention thereto.

Fig. 2 is a detailed sectional view of the connection between the lower end of the valve stem and spring.

Fig. 3 is a sectional view of the parts shown in Fig. 2 in position to permit removal of the valve.

Fig. 4 is a detail perspective view of one of the retainer elements.

Referring to the drawing wherein a preferred, but not necessarily the only embodiment of the invention is illustrated, the numeral 1 indicates a cylinder block having a head 2 removably secured thereon and which provides a combustion chamber 3. Explosions occurring in the combustion chamber are received by the reciprocatory piston 4 to impart a rotational movement to the engine crankshaft. Driven from and rotated in timed relation with the crankshaft is a cam shaft 5, carrying a series of cams for operating a number of suitable valves controlling the intake and exhaust of gases to and from the combustion chamber 3. Only one of the valves and its operative mechanism is shown in the drawing and this consists of a cam 6, acting on a rocker arm 7, loosely pivoted on the shaft 8 for engagement with the bottom of the valve stem 9, which has a bearing in the bushing or guide 10 and is provided with a head 11 controlling communication between the port 12 and combustion chamber 3. A coiled tension spring 13 bears against a retainer collar or washer 14 carried on the lower end of the valve stem for maintaining the valve head on its seat as will be readily understood.

The retainer collar or washer 14 is provided with an upwardly and inwardly extending annular flange 15 of substantially ogee or S-shape in vertical section, which surrounds a pair of semi-circular sheet metal stampings or pawl elements 16 and 17 also of substantially S-shape in section and which have end portions 18 and 19 respectively adapted to extend into an annular groove 20 adjacent the lower end of the valve stem and to bear against the shoulder formed by the groove. The shape of the pawl elements provides upper and lower oppositely or reversely inclined bearing surfaces for the collar. For convenience and economy of manufacture the two pawl elements 16 and 17 are preferably complements of each other and each is provided with a projection or ear 21 at one side and at the other side with a corresponding notch or

opening 22, the ear of one pawl being adapted to extend into the notch of the other pawl to afford an interlock between the two parts to prevent their relative axial movement.

5 The two pawl elements form in effect a pair of co-operating jaws which are rockable one about the other upon relative axial movement of the collar 14 to swing the end portions 18 and 19 into or out of the annular notch 20.

10 In the position of the parts shown in Figure 2 the tension of the coiled spring 13 causes the flange 15 to bear on the lower substantially inclined surfaces of the pawl elements to draw and hold the jaws in tight contact or engagement with the valve stem. When it is desired to remove the valve from the engine, as for instance when replacement or re-seating becomes necessary, the cover plate 25 is removed from over the opening in the side wall to the cylinder block and a suitable tool is introduced for engagement beneath the collar 14 to lift the collar against the tension of the spring 15. As the collar is moved upwardly its upper end will engage with and ride on the substantially inclined surfaces at the top of the pawl elements and cause the pawl elements to rock about each other swinging the end portions 18 and 19 out of the groove until the parts assume the position shown in Figure 3 at which time the valve may be lifted and removed by the fingers. To replace the valve the procedure is reversed. Thus there will be no necessity for the operator to insert his fingers through the opening of the cylinder block to manipulate keys or lock washers, as is the case with the various types of valve spring retainers now in general use. The fact that very little clearance space is necessary to accomplish removal or replacement of valves has the further advantage of facilitating a more compact design of engine.

I claim:

45 1. A valve spring retainer including a pair of pawl elements, each having oppositely disposed inclined bearing surfaces, a collar surrounding the pawl elements and movable in relation therewith to engage one or the other of said surfaces of the respective pawl elements to move the pawl elements into or out of engagement with a valve stem dependent upon the surfaces engaged.

55 2. A valve spring retainer comprising a series of circumferentially arranged pawl elements each having oppositely inclined cam surfaces, a collar surrounding the pawl elements and movable in one direction to engage one of the cam surfaces of each of said pawl elements, and movable in another direction to engage another of the cam surfaces of each of said elements, whereby the pawl elements are adapted to be moved either into or out of engagement with a 65 valve stem.

3. A valve spring retainer, comprising a series of circumferentially arranged pawl elements having reversely inclined bearing surfaces, a collar adapted to ride on the inclined surfaces and movable axially thereof in opposite directions to move the pawl elements into or out of engagement with a valve stem dependent upon the direction of movement and the surfaces engaged thereby.

70 4. A valve spring retainer, comprising a series of pawl elements each having inclined bearing surfaces extending angularly in opposite directions, a collar surrounding the pawl elements and adapted to ride on the respective inclined surfaces of the pawl elements and having a bearing portion for a valve spring, said collar being movable axially of the pawl elements, whereby its engagement with the respective inclined surfaces upon movement in opposite directions is adapted to cause the pawl elements to move into or out of engagement with a valve stem.

80 5. A valve spring retainer comprising a series of circumferentially arranged pawl elements having substantially inclined portions and having interlocking engagement with each other and adapted for relative rocking movement into or out of engagement with a valve stem, a collar forming a bearing for a valve spring, having an inwardly inclined annular flange that is adapted to ride on said inclined portions of the pawl elements to rock the same.

90 6. A valve spring retainer comprising a pair of semi-circular pawl elements of substantially S-shape in section, having an interlocking ear and notch formed adjacent one end of the respective elements, the opposite end of each element having a portion to be projected into a groove in a valve stem, and a collar surrounding the elements having an annular flange also of substantially S-shape in section, and which is adapted to ride on corresponding surfaces of the pawl elements upon relative axial movement of the collar to cause the elements to swing relative to each other into or out of the groove in the valve stem.

105 7. A valve spring retainer comprising a pair of complementary semi-circular pawl elements of substantially S-shape in section, each pawl element having a tongue at one side and a notch in the other side, the tongue on one element being adapted to project into the corresponding notch in the other element to form an interlock between the elements, and a collar surrounding the elements and movable axially thereof to engage with the surfaces thereof to rock said elements about each other into or out of engagement with a valve stem extended therethrough.

120 8. The combination with a poppet valve having a stem provided with an annular 130

groove, and a spring adapted to yieldingly hold the valve on its seat, of a spring retainer detachably engageable with the stem and comprising a plurality of pawl elements having interlocking engagement with each other and provided with substantially inclined surfaces and with portions for engagement within the annular groove on the valve stem, and a collar surrounding said elements on which the spring bears, said collar being movable axially of the elements for sliding contact on said inclined surfaces thereof to swing said elements into or out of engagement with said groove.

15 In testimony whereof I affix my signature.
GEORGE W. LAMPMAN.

20

25

30

35

40

45

50

55

60

65