

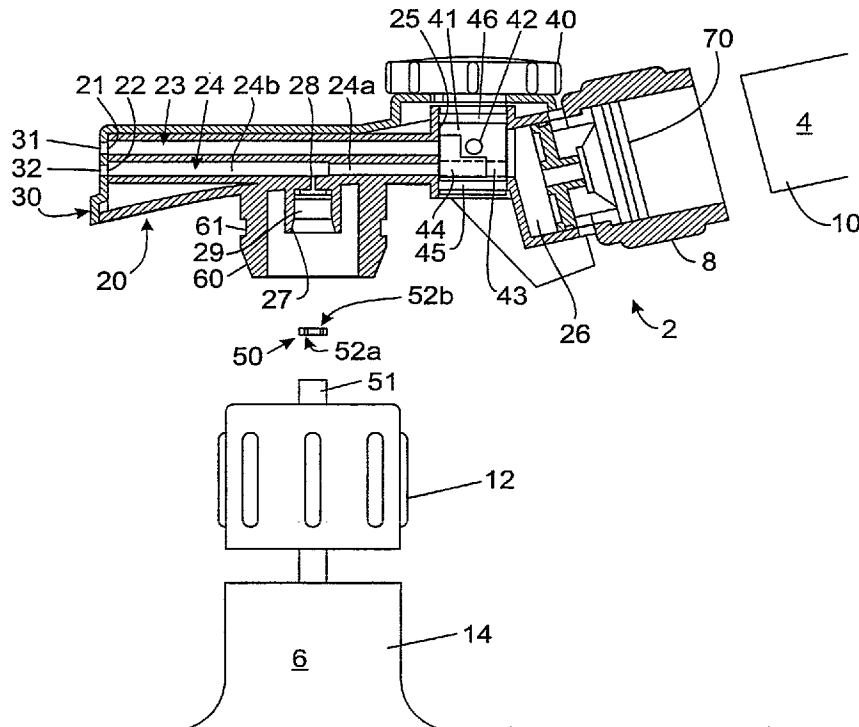

(72) CHURA, William D., US
(72) KOZLOWSKI, Edward, US
(72) LILJEQVIST, Lance, US
(72) JONES, Stephen, US
(72) THOMPSON, Mark, US
(72) HAWES, Charles, US
(71) ARMOR ALL PRODUCTS CORPORATION, US
(51) Int. Cl.⁶ B05B 7/30, A62C 5/02, B05B 7/24
(30) 1995/05/26 (08/451,922) US
(30) 1995/08/04 (08/511,142) US
(54) **VAPORISEUR A DOUBLE CYLINDRE**
(54) **DOUBLE BARREL SPRAYER**



(57) Le vaporiseur à double cylindre décrit (2) sert à appliquer un produit dilué, tel qu'une solution détergente diluée, sur une surface, afin de nettoyer la surface, et à rincer le produit dilué de la surface en vaporisant uniquement de l'eau sur la surface. Le vaporiseur (2) peut comprendre une plaque perforée (50) ajustée serrée pourvue d'un ou plusieurs trous (52a et 52b) pour ajuster le rapport de mélange entre l'eau et le produit ou une pièce rapportée pourvue de passages qui permet

(57) A double barrel sprayer (2) for applying a diluted product such as a diluted cleaning solution to a surface for cleaning thereof and rinsing the diluted product from the surface by spraying a water-only rinse onto the surface. The sprayer (2) can include a force fitted orifice plate (50) with one or more holes (52a and 52b) for adjusting the water/product mixing ratio or an insert having passages therein for providing a desired product dilution ratio. To provide different spray patterns for the



(21) (A1) **2,220,521**
(86) 1996/05/23
(87) 1996/11/28

d'obtenir le rapport de dilution voulu du produit. Afin d'obtenir différents motifs de vaporisation de l'eau de rinçage ou du produit dilué, le vaporisateur (2) peut comprendre un voile pourvu d'orifices de sortie de forme appropriée. Le vaporisateur (2) comprend des voies d'écoulement séparées de l'eau de rinçage (23) et du produit dilué (24). La voie d'écoulement du produit dilué (24) comprend une chambre de mélange (28) dans laquelle le produit concentré contenu dans un récipient (6) est aspiré et mélangé avec de l'eau fournie par un tuyau d'arrosage (4). Avant de se mélanger avec l'eau, le produit concentré passe à travers la plaque perforée (50) ou la pièce rapportée, de sorte qu'un rapport de mélange sensiblement constant entre l'eau et le produit soit obtenu dans une large plage de pressions d'eau. Le vaporisateur (2) comprend un couvercle amovible (30) pourvu d'une paire d'orifices de sortie de taille et de forme appropriées qui permettent d'obtenir les motifs voulus de vaporisation de l'eau de rinçage et du produit dilué vaporisés par le vaporisateur (2). Une soupape rotative (40) permet d'appliquer sélectivement l'eau ou le produit dilué.

water-rinse or diluted product, the sprayer (2) can include a shroud having suitably shaped exit holes. The sprayer (2) includes separate flow paths for water-only rinse (23) and the diluted product (24). The flow path for the diluted product (24) includes a mixing chamber (28) in which concentrated product is siphoned from a container (6) and mixed with water supplied by a garden hose (4). Prior to mixing with the water, the concentrated product passes through the orifice plate (50) or insert to provide a substantially constant water/product ratio over a wide range of water pressures. The sprayer (2) includes a removable cover (30) which includes a pair of outlets suitably sized and shaped to obtain desirable spray patterns for water-only rinse and the diluted product sprayed from the sprayer (2). A rotatable valve (40) allows selective application of water or diluted product.





<p>(51) International Patent Classification ⁶ : A62C 5/02</p>	<p>A1</p>	<p>(11) International Publication Number: WO 96/37261 (43) International Publication Date: 28 November 1996 (28.11.96)</p>
<p>(21) International Application Number: PCT/US96/07749 (22) International Filing Date: 23 May 1996 (23.05.96) (30) Priority Data: 08/451,922 26 May 1995 (26.05.95) US 08/511,142 4 August 1995 (04.08.95) US (71) Applicant: ARMOR ALL PRODUCTS CORPORATION [US/US]; 385 Meeting Street, Charleston, SC 29401 (US). (72) Inventors: CHURA, William, D.; 509 Main Street, Ridgefield, CT 06877 (US). KOZLOWSKI, Edward; 193 Arbor Drive, Southport, CT 06490 (US). LILJEQVIST, Lance; 161 Huckleberry Road, Wilton, CT 06897 (US). JONES, Stephen; 71 Relihan Road, Darien, CT 06820 (US). THOMPSON, Mark; 1231 Fort Lamar Road, Charleston, SC 29412 (US). HAWES, Charles; 1004 Bryce Court, Summerville, SC 29438 (US). (74) Agent: SKIFF, Peter, K.; Burns, Doane, Swecker & Mathis, L.L.P., P.O. Box 1404, Alexandria, VA 22313-1404 (US).</p>	<p>(81) Designated States: AL, AM, AT, AU, AZ, BB, BG, BR, BY, CA, CH, CN, CZ, DE, DK, EE, ES, FI, GB, GE, HU, IS, JP, KE, KG, KP, KR, KZ, LK, LR, LS, LT, LU, LV, MD, MG, MK, MN, MW, MX, NO, NZ, PL, PT, RO, RU, SD, SE, SG, SI, SK, TJ, TM, TR, TT, UA, UG, UZ, VN, ARIPO patent (KE, LS, MW, SD, SZ, UG), Eurasian patent (AM, AZ, BY, KG, KZ, MD, RU, TJ, TM), European patent (AT, BE, CH, DE, DK, ES, FI, FR, GB, GR, IE, IT, LU, MC, NL, PT, SE), OAPI patent (BF, BJ, CF, CG, CI, CM, GA, GN, ML, MR, NE, SN, TD, TG).</p> <p>Published <i>With international search report.</i></p>	

(54) Title: DOUBLE BARREL SPRAYER

(57) Abstract

A double barrel sprayer (2) for applying a diluted product such as a diluted cleaning solution to a surface for cleaning thereof and rinsing the diluted product from the surface by spraying a water-only rinse onto the surface. The sprayer (2) can include a force fitted orifice plate (50) with one or more holes (52a and 52b) for adjusting the water/product mixing ratio or an insert having passages therein for providing a desired product dilution ratio. To provide different spray patterns for the water-rinse or diluted product, the sprayer (2) can include a shroud having suitably shaped exit holes. The sprayer (2) includes separate flow paths for water-only rinse (23) and the diluted product (24). The flow path for the diluted product (24) includes a mixing chamber (28) in which concentrated product is siphoned from a container (6) and mixed with water supplied by a garden hose (4). Prior to mixing with the water, the concentrated product passes through the orifice plate (50) or insert to provide a substantially constant water/product ratio over a wide range of water pressures. The sprayer (2) includes a removable cover (30) which includes a pair of outlets suitably sized and shaped to obtain desirable spray patterns for water-only rinse and the diluted product sprayed from the sprayer (2). A rotatable valve (40) allows selective application of water or diluted product.

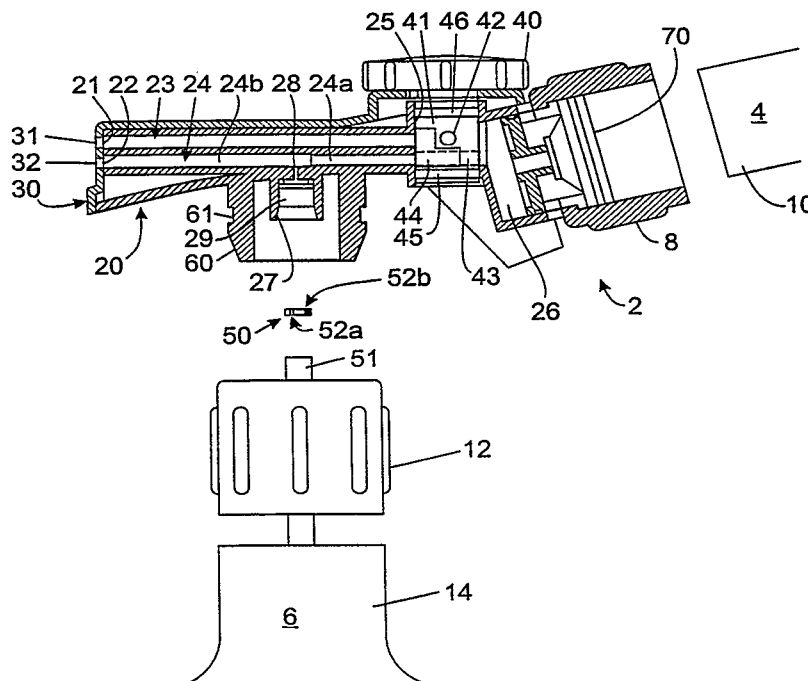

* (Referred to in PCT Gazette No. 20/1997, Section II)

-1-

DOUBLE BARREL SPRAYER

FIELD OF THE INVENTION

The invention relates generally to mixing and dispensing sprayers and more particularly to a sprayer for use in mixing a concentrated liquid product with water in a desired water/product ratio and spraying the diluted product onto a surface to be treated. The sprayer also can be used to apply a water-only rinse to remove the product from the surface.

BACKGROUND OF THE INVENTION

Sprayers for mixing and dispensing liquids into a carrier fluid such as water are disclosed in U.S. Patent Nos. 3,201,049; 3,381,899; 5,039,016; 5,100,059; 5,213,265; and 5,383,603. Such sprayer arrangements typically include an inlet for a hose such as a garden hose and an inlet for a siphon tube for removing product from a container attached to the sprayer. The sprayer arrangements vary in complexity and typically spray a water/product mixture or water-only through a common outlet of the sprayer. Further, in some of the prior art arrangements, the product to be mixed with water is mixed in a chamber exposed to the atmosphere which results in fluctuation in the water/product ratio. Another disadvantage of such prior art sprayers is that they may not be capable of delivering a water/product mixture or water-only rinse over a suitable distance.

There is a need in the art for a sprayer apparatus for cleaning buildings which can provide selective application of a water/product mixture or water-only rinse at distances capable of reaching the entire wall surface of a two-story building, providing a desired water/product mixing ratio over the wide range of water pressures typically found in residential garden hoses and/or providing adaptability with respect to the desired water/product mixing ratio and/or shape of spray patterns of the product/water mixture and water-only rinse spray patterns provided by the sprayer.

-2-

SUMMARY OF THE INVENTION

The invention provides a portable double barrel sprayer for applying a diluted liquid product to a surface to be treated. The sprayer includes a housing having first and second inlets, first and second outlets, a mixing chamber and a valve member.

5 The first inlet is attachable to a hose which supplies water to the sprayer, the second inlet is attachable to a container which supplies a concentrated liquid product to the sprayer, and the mixing chamber is in fluid communication with the first and second inlets such that water is mixed with the concentrated liquid product to form a diluted product by feeding water through the first inlet and feeding the concentrated liquid
10 product through the second inlet. The first outlet sprays rinsing water from the sprayer to allow removal of diluted product from a surface to be treated, the second outlet sprays the diluted product from the sprayer onto a surface to be treated, and the valve member selectively feeds the diluted product to the second outlet or feeds only rinsing water to the first outlet.

15 The sprayer can include a variety of optional features. For instance, the sprayer can include a siphoning tube extending into a container of the concentrated liquid product such that the second inlet is in fluid communication with the siphoning tube. The concentrated product can be removed from the container by feeding water through the mixing chamber and siphoning the concentrated product from the
20 container. The shape of the spray patterns can be controlled by a cover member attached to the housing such that a first outlet of desired shape of the cover member is in fluid communication with the first outlet of a housing and the second outlet of desired shape of the cover member is in fluid communication with the second outlet of the housing. The sprayer can include an orifice member in fluid communication with
25 the second inlet and having one or more passages to supply concentrated product to the mixing chamber in a substantially constant water/product ratio. Alternatively, the mixing chamber can be provided in an insert fitted in the housing, the insert including an inlet passage receiving water, a supply passage receiving concentrated liquid product and an outlet passage wherein the product and water are mixed and passed to
30 the second outlet. The sprayer can include an antisiphoning device in fluid

-3-

communication with the first inlet to prevent concentrated liquid product from flowing outwardly of the first inlet.

The valve member of the sprayer can be a rotatable valve having a cylindrical body with upper and lower passages therethrough, the upper passage being in fluid communication with the first inlet and first outlet when the rotatable valve is in a first position and the lower passage being in fluid communication with the second outlet when the rotatable valve is rotated from the first position to a second position at which the upper passage is not in fluid communication with the first outlet. The housing can include a bore receiving the cylindrical body of the valve member and the housing can include an upper passage in fluid communication with the bore and first outlet and a lower passage in fluid communication with the bore and the second outlet. The valve member can include a seal member which sealingly engages with the upper and lower passages when the valve member is in an off position. The housing can include a cavity in fluid communication with the bore and the first inlet, the valve member being movable from the first position at which the cavity is in fluid communication with only the upper passage to the second position at which the cavity is only in fluid communication with the lower passage. The lower passage preferably includes an upstream portion and a downstream portion, the second inlet being in fluid communication with the downstream portion, and the downstream portion having a larger cross section than the upstream portion so that concentrated liquid product is siphoned into the downstream portion and mixed with water supplied through the upstream portion.

The water and concentrated liquid product can be supplied to the sprayer by a water hose and a container of the product, respectively. To attach the container, the housing can include a tubular projection and a rotatable fitting mounted on the tubular projection such that the rotatable fitting is engageable with the container. To attach the hose, the first inlet can comprise an internally threaded portion of the housing and the internally threaded portion can be attachable to a hose by screwing the internally threaded portion onto an externally threaded portion of the hose. Alternatively, the housing can include a tubular projection and a rotatable fitting mounted on the tubular projection such that the rotatable fitting is engageable with an end of the hose. The

-4-

housing can comprise a single molded piece of plastic having an upper passage therethrough in fluid communication with the first outlet, a lower passage therethrough in fluid communication with the second outlet, and the mixing chamber located in the second passage.

5 The invention also provides a method of applying diluted liquid product to a surface to be treated by a sprayer attached to a hose for supplying water to a first inlet of the sprayer and a container having concentrated liquid product attached to a second inlet of the sprayer. The method includes spraying water through a first outlet
10 in the sprayer by moving a valve member of the sprayer to a first position at which the first inlet is in fluid communication with the first outlet. The method also includes mixing the concentrated liquid product with water to form a diluted product and spraying the diluted product from a second outlet in the sprayer by moving the valve member to a second position at which the first inlet is in fluid communication
15 with the second outlet. The concentrated liquid product is preferably siphoned from the container and passes through an orifice plate having one or more openings therein to provide a substantially constant water/product ratio over water pressure variations in the water supplied through the inlet ranging from 40 to 60 psi. To provide desired spray patterns, the sprayer can include a cover mounted on the housing, the cover including a first outlet in fluid communication with the first outlet of the housing and
20 a second outlet in fluid communication with the second outlet of the housing, the first and second outlets in the cover providing different spray patterns of the water-only rinse and diluted product, respectively. In a preferred embodiment, the concentrated liquid product is a concentrated liquid cleaning solution and the method comprises cleaning an outdoor surface such as vinyl by applying the diluted product to the
25 surface, allowing the diluted product to remain on the surface for a period of time followed by rinsing the diluted product from the surface by spraying water through the first outlet of the sprayer.

-5-

BRIEF DESCRIPTION OF THE DRAWINGS

Fig. 1 shows a sprayer in accordance with the invention in a partially exploded and cross-sectional view;

Fig. 2 shows a cross-sectional view of a housing of the sprayer shown in
5 Fig. 1;

Figs. 3a-c show details of the cover shown in Fig. 1, wherein Fig. 3a shows a longitudinal cross-sectional view of the cover, Fig. 3b shows a transverse cross-sectional view taken along the line A-A in Fig. 3a and Fig. 3c shows a top view of the cover shown in Fig. 3a;

10 Fig. 4 shows details of the multi-position valve shown in Fig. 1;

Figs. 5a-d show details of an antisiphoning device shown in Fig. 1 wherein Fig. 5a is an axial end view of a cylindrical member, Fig. 5b is a cross-sectional side view of the cylindrical member of Fig. 5a, Fig. 5c is a perspective side view of the cylindrical member shown in Figs. 5a-b and Fig. 5d is a side view of a conical
15 member which together with the cylindrical member forms the antisiphoning device;

Figs. 6a-b show details of the housing of the sprayer shown in Fig. 1, Fig. 6a showing an axial end view in partial cross-section of the housing and Fig. 6b showing a top view of the housing;

Figs. 7a-c show details of an embodiment of the housing of the sprayer shown
20 in Fig. 1, Fig. 7a showing a top view in cross-section of a snap-on spray pattern member, Fig. 7b showing a side view in cross-section of the member shown in Fig. 7a, and Fig. 7c showing a front view of the member shown in Fig. 7a;

Figs. 8a-b show details of an embodiment of the orifice plate shown in Fig. 1;
and

25 Figs. 9a-e show details of a modification of the sprayer shown in Fig. 1.

DETAILED DESCRIPTION OF THE INVENTION

According to the invention, an improved sprayer is provided having improved consistency in water/product mixing ratios, range of delivery and/or different spray patterns for a water-only rinse or water/product mixture. The sprayer can incorporate
30 a closed venturi system, an orifice plate delivery mechanism, an insert providing

-6-

mixing at a desired ratio and/or a dual chamber exit for delivery of water-only from one exit hole and product from the other exit hole. The sprayer can also include a three-position valve for supplying water-only in a first position, a water/product mixture in a second position and preventing outflow of product or water in a third
5 position.

As shown in Fig. 1, the invention provides a sprayer 2 attachable to a free end of a hose 4 such as a garden hose. The sprayer is also attachable to a container 6 of product such as a concentrated cleaning solution. The concentrated cleaning solution can be a cleaning solution suitable for cleaning vinyl siding such as the cleaning
10 solution disclosed in copending and commonly owned U.S. patent application Serial No. 08/383,769, the disclosure of which is hereby incorporated by reference. The product is withdrawn from container 6 and mixed with a pressurized liquid such as water supplied by hose 4.

The sprayer 2 includes a first internally threaded fitting 8 for attachment to a
15 threaded end 10 of hose 4 and a second internally threaded rotatable fitting 12 for attachment to a threaded outlet of 14 of container 6. Alternatively, a rotatable fitting could be used for attaching the hose 4 to the sprayer. Further, other methods of attaching hose 4 and container 6 could be substituted for the threaded fittings 8, 12, e.g., snap fittings, compression fittings, etc.

According to a preferred embodiment, sprayer 2 includes a housing 20, cover
20 30 and valve member 40. As shown in Fig. 2, the housing 20 has a dual outlet arrangement wherein an upper outlet 21 is a water-only outlet and a lower outlet 22 is a diluted product outlet. Likewise, as shown in Figs. 3a-c, the cover 30 has an upper water-only outlet 31 and a lower diluted product outlet 32. The upper outlet 31 is
25 supplied water through upper passage 23 in housing 20 and the lower outlet 32 is supplied diluted product through lower passage 24 in housing 20. With this arrangement, outlets 31, 32 can have different shapes and/or sizes to selectively provide desired spray patterns for the water-only and diluted product sprayed from the sprayer. For instance, by proper choice of the outlet size and/or shape, it is possible
30 to apply the diluted product in a wide pattern and/or with moderate impact force on a surface to be coated with the diluted product. On the other hand, since the water-only

-7-

rinse is applied through a different outlet, it is possible to apply the water-only rinse to the surface with a more narrow spray pattern and/or with greater impact force compared to the diluted product spray pattern.

With the dual outlet arrangement, it is desirable to utilize a multi-position valve member 40, as shown in Fig. 4, for selectively applying the water-only or diluted product to the respective outlets 31, 32. The valve member 40 is movable to first, second and third positions whereby outlets 31, 32 are prevented from spraying water-only or diluted product when valve member 40 is in the third position, outlet 32 is supplied diluted product and outlet 31 is prevented from spraying water-only when valve member 40 is in the second position and outlet 31 is supplied water-only and outlet 32 is prevented from spraying diluted product when valve member 40 is in the first position.

As shown in Fig. 4, the valve member 40 includes a cylindrical body 41 having upper passage 42 and lower passage 43. In order to supply water from hose 4 to passages 42 and 43, housing 20 includes a cavity 26 which is in fluid communication with upper and lower passages 42, 43. Body 41 is rotatably mounted in bore 25 of housing 20 such that upper passage 42 supplies water to upper outlet 31 through upper passage 23 when valve member 40 is in the first position. By rotating valve member 40 to the second position, upper passage 42 is rotated out of fluid communication with upper passage 23 and lower passage 43 in body 41 is aligned with lower passage 24 so that diluted product can be supplied to lower outlet 32. By rotating valve member 40 to the third position, upper passage 42 is out of fluid communication with upper passage 23 and lower passage 43 is out of fluid communication with lower passage 24. To prevent leakage, body 41 includes seal member 44 which sealingly engages inlets of passages 23, 24 and upper O-ring 45 and lower O-ring 46 prevent leakage between valve member 40 and housing 20.

In another preferred embodiment of the invention, concentrated product in container 6 is supplied to lower passage 24 via an orifice plate arrangement 50 mounted in tubular projection 27 in housing 20. In particular, concentrated product is withdrawn from container 6 through tube 51, passes through a plurality of holes 52a, 52b in orifice plate 52, through passage 28 in housing 20 and into lower passage

-8-

24. As shown in Fig. 2, plate 52 tightly fits within an opening 29 defined by tubular projection 27 and a free end of tube 51 sealingly engages the opening 29 such that plate 52 is located between tube 51 and passage 28. The orifice plate arrangement provides more uniform and consistent mixing of concentrated product with water
5 within a desired range of water/product mixing ratios (e.g. 10 to 30 parts water to 1 part concentrated liquid product) over a wide range of water pressures (e.g., 40 to 60 psi) typically supplied by household exterior faucets.

According to a further embodiment of the invention, concentrated product is mixed with water in a closed venturi system. In particular, compared to prior art
10 sprayers which utilize an open air mixing chamber, sprayer 2 achieves mixing of concentrated product from container 6 and water from hose 4 in lower passage 24 by providing passage 24 with a small diameter upstream portion 24a and a large diameter downstream portion 24b. To enhance mixing, upstream portion 24a can have a non-circular cross-section and downstream portion 24b can have a circular cross-section.
15 Passage 28 is in fluid communication with downstream portion 24b and water passing under pressure through upstream passage 24a drops in pressure in downstream passage 24b thus creating a partial vacuum in an area of passage 28 and drawing concentrated product up through tube 51 and into downstream passage 24b wherein the concentrated product is thoroughly mixed with the water.

20 According to another embodiment of the invention, fitting 8 is integral with housing 20, e.g., fitting 8 and housing 20 can be injection molded from plastic in one piece, as shown in Fig. 2. In this case, the housing can be screwed onto the hose 4 prior to attaching the container 6. To allow easier attachment of container 6, housing 20 can include a tubular projection 60 which has an annular recess 61 on the outer
25 periphery thereof. Fitting 12 snap fits over projection 60 by engaging recess 61 with a suitable mating annular flange (not shown) whereby end 14 of container 6 can be screwed into fitting 12 by rotating fitting 12. If desired, another rotatable fitting arrangement as used to attach container 6 can be used to attach hose 4.

The sprayer 2 can include an antisiphoning device 70 to prevent backflow of
30 concentrated liquid product outwardly of inlet 8 and into hose 4. As shown in Figs. 5a-d, device 70 includes cylindrical member 71 having a central passage 72

-9-

therein for directing water to cavity 26, O-ring 72 for sealingly engaging an outer periphery of member 71 with an inner wall of fitting 8 and conical member 74 having a conical wall 75 and central passage 76 in fluid communication with passage 72.

The antisiphoning device includes a flapper (not shown) to prevent backflow of fluid in the hose 4. The antisiphoning device can have other suitable configurations such as of the type incorporated in aspiration-type sprayers made by Hayes Products or comprise a backflow valve as disclosed in U.S. Patent No. 2,646,063.

As shown in Figs. 6a-b, housing 20 includes snap fitting member 80 which engages mating projection 34 on cover 30 (see Fig. 3a). With this arrangement, cover 30 can be replaced or interchanged with another cover having different size and/or shaped outlets 31, 32. Also, cover 30 can include a deflector for diverting the water-rinse or diluted product sprayed from exit holes 31 and/or 32. For instance, as shown in phantom in Fig. 3a, cover 30 can include deflector 35 for diverting the diluted product spray thus providing a wide spray pattern for spraying the diluted product on nearby horizontal surfaces such as wooden decks, driveways, etc.

With the sprayer arrangement described above, it is possible to mix highly concentrated cleaning solution with water supplied from a garden hose and apply the thus diluted cleaning solution to outdoor surfaces such as vinyl siding of a building. The sprayer can provide a one-foot wide spray pattern at a distance of 8 feet. Further, at a water pressure of 60 psi at the hose end, the sprayer can deliver the diluted product to heights of 30 feet and provide a rinsing spray of water-only at such distances. Moreover, the delivery of product and water-only rinse to the desired distances such as the top of a two-story wall of a building can be achieved while maintaining a substantially constant water/product mix ratio, e.g., 20:1 water to product ratio.

In accordance with a preferred embodiment of the invention, a mixing ratio of about 20:1 water to product is achieved using an orifice disk with two holes having diameters of 0.031 inch and configuring the lower passage 24 such that the upstream portion 24a has a diameter of 0.092 inch and the downstream portion 24b has a diameter of 0.116 inch. Also, water and concentrated product are mixed in downstream portion 24b which has length of 0.875 inch. The upper passage 23 for

-10-

the water rinse has a diameter of 0.140 inch. This arrangement was compared to a single orifice arrangement having a orifice disk with a single hole having a diameter of 0.042 inch. The results of the testing are set forth in the following Table 1.

TABLE 1

		Water Pressure	40 P.S.I.	50 P.S.I.	60 P.S.I.
5	Single Orifice	Time/10 Gals. Water/Product	7 Min. 5 Sec.	6 Min. 10 Sec.	5 Min. 35 Sec.
		Product Flow	54 Ozs.	64 Ozs.	76 Ozs.
		Water/Product Ratio	22.70:1	19:1	15.84:1
		Time/24 Ozs. Product	3 Min. 9 Sec.	2 Min. 19 Sec.	1 Min. 46 Sec.
	Double Orifice	Time/10 Gals. Water/Product	7 Min.	6 Min. 5 Sec.	5 Min. 30 Sec.
		Product Flow	56 Ozs.	56 Ozs.	57½ Ozs.
		Water/Product Ratio	21.85:1	21.85:1	21.26:1
		Time/24 Ozs. Product	3 Min.	2 Min. 36 Sec.	2 Min. 18 Sec.

As shown in the above Table 1, with the double orifice arrangement according to the invention, it is possible to maintain a desired water/product ratio of about 21 to 22:1 over a water pressure range of 40-60 psi whereas with a single orifice arrangement the water:product ratio varied widely from about 16 to 23:1 over the same water pressure range.

A variation of the cover 30 is shown in Figs. 7a-c. In this embodiment, outlets 31,32 of cover 30 can be omitted and instead a larger single opening 36 can be provided in cover 30, as shown in phantom in Fig. 3b. Opening 36 should be large enough to allow rinse water flowing through passage 23 or diluted product flowing through passage 24a to pass therethrough. In order to provide desired spray patterns for the rinse and diluted product, respectively, snap-on spray pattern member 80 includes outlets 31a,32a extending therethrough. Outlet 31a is aligned with passage 23 and outlet 32a is aligned with passage 24a when member 80 is attached to cover 30. In order to attach member 80 to cover 30, cover 30 includes openings 37,38 (as shown in phantom in Fig. 3c) and member 80 includes snap-fit projections 81,82 thereon for engaging openings 37,38. Each of the exit portions of outlets 31a,32a is

-11-

rectangular in shape, as shown in Fig. 7c. Each outlet 31a,32a includes a first V-shaped tapered portion 83 and a second rectangular shaped portion 84 of uniform cross-section, as shown in Fig. 7a. As shown in Fig. 7c, the tapered portion 83 is formed by a pair of planar vertical walls which converge towards the portion 84 of uniform cross-section. In the embodiment shown, the outlets 31a,32a have exit openings in the shape of rectangles which are 0.092 inch in horizontal dimension and 0.20 inch in vertical dimension. The tapered portion 83 has an entrance opening in the shape of a square with dimensions of 0.20 inch on each side. The outlets 31a,32a, however, can have any suitable size and/or shape. Thus, the arrangement shown in Figs. 7a-c allows the spray pattern to be easily changed by attaching member 80 having the desired size and/or shaped outlets therein.

As shown in Figs. 8a-b, the orifice plate 52 can be mounted in the upper end of the tube 51. In this case, orifice plate 52 can include a single orifice 52c extending axially through projection 53. Projection 53 tightly fits within the opening of tube 51, thus allowing easy mounting of the orifice plate and simple adjustment of product dilution ratios based on the size of the opening 52c. Tube 51 can comprise a standard dip tube having an inner diameter of 0.1875 inch and an outer diameter of 0.25 inch. Projection 53 and orifice plate 52 can be molded as a single piece of plastic or other material having a length of about 0.125 inch. With this arrangement, orifice plate 52 can be located between tube 51 and passage 28 with tube 51 sealingly engaging opening 29. Product dilution ratios obtainable with different hole sizes 52c are exemplified in the following Table 2.

TABLE 2

Water/ Product Ratio	10:1	11:1	12:1	13:1	14:1	15:1	16:1	17:1	18:1	19:1	20:1
Orifice Diameter (inch)	0.043	0.042	0.041	0.040	0.039	0.038	0.037	0.036	0.035	0.034	0.033

A modified version of the sprayer arrangement shown in Fig. 1 is shown in Figs. 9a-e, wherein the spray gun 100 includes an insert 110 which provides a desired

-12-

ratio of incoming water to concentrated product such as a concentrated cleaning solution. Details of the insert are shown in Figs. 9c-d.

The insert 110 includes a recess 112 for receiving an upper end of the siphon tube 51 (shown in Fig. 1), an inlet passage 114 for directing water from upstream passage 24a to downstream passage 24b, an outlet passage 116 for directing diluted cleaning solution to downstream passage 24b, and a supply passage 118 for flow via suction of concentrated cleaning solution from the siphon tube 51 to outlet 116. The shapes and sizes of outlet 116, inlet 114 and/or passage 118 can be adjusted relative to each other to achieve a desired dilution of concentrated cleaning solution with the water supplied from passage 24a.

The insert 110 is cylindrical in shape and slides into recess 120 in the spray gun 100 until the insert engages an abutment surface 121. To ensure alignment of inlet passage 114, and outlet passage 116 with passages 24a, 24b, the insert 110 includes an axially extending projection 122 which fits in a mating slot 124 in the spray gun. Alternatively, the insert and mating recess can have non-circular shapes such as a flat on one side, polygonal shape, etc., to provide alignment of the flow passages and thus obviate the projection and slot.

In accordance with a preferred embodiment of the insert, the insert 110 is 0.375 inch in diameter and 0.854 inch long. The projection 122 has a width of 0.040 inch, a length of 0.438 inch and projects 0.0395 inch beyond the outer cylindrical surface of the insert. The supply passage 118 has a diameter of 0.035 inch, the inlet passage 114 has a diameter of 0.042 inch and the outlet passage 116 has a diameter of 0.079 inch. The bore forming the outlet passage 116 includes an end face extending perpendicular to the axis of the bore thus forming sharp corners 126.

The recess 112 has a diameter sized to provide a snug fit with the siphon tube 51. To aid retention of and/or provide a good seal with the siphon tube 51, a rib 128 is provided adjacent a conical entrance portion 130 of the recess 112. If desired, supply passage 118 can be aligned with a similarly sized hole through the upper end 132 of the insert 112 but the hole through end 132 can be eliminated. The end face of the bore forming outlet passage 116 is located 0.0075 inch beyond the outer periphery of the supply passage 118. The outlet passage 116 and inlet passage 114

-13-

are axially aligned and the central axis thereof is located 0.160 inch below upper end 132. To reduce friction during insertion of the insert 110 in the recess 120 of the spray gun 100, upper end 132 includes a 0.020 inch wide 45° chamfer 134 on the outer edge thereof.

5 Fig. 9a shows the insert fitted in spray gun 100. The recess 120 in the spray gun 100 has an end wall 136 located 0.160 inch above the central axis of upstream passage 24a and upper end 132 of the insert provides an abutment which fits against the end wall 136. As shown in Fig. 9a, the inlet passage 114 has a smaller diameter than the outlet passage 116, the outlet passage 116 has a smaller diameter than the
10 upstream passage 24a and the upstream passage 24a has a smaller diameter than the downstream passage 24b. The supply passage 118 has a diameter larger than that of inlet passage 114 but smaller than that of outlet passage 116. With this arrangement, mixing of the concentrated product occurs in the space where the water supply passage 114 and product supply passage 118 open into outlet passage 116.

15 The step change between water supply passage 114 and outlet passage 116 create a pressure drop which draws concentrated product through product supply passage 118 into outlet passage 116. For instance, the outlet passage 116 can be at least 50% larger in cross section than the inlet passage 114. In the embodiment shown, the water supply passage 114 has a cross sectional area about 18% of the
20 cross sectional area of outlet passage 116. Such an arrangement creates enough of a siphon effect to draw concentrated product upwardly through the product supply passage 118, which has a cross sectional area of about 12% of that of outlet passage 116. It will be apparent to those skilled in the art that alternative arrangements could be used for supplying the concentrated product to mix with the water.

25 The foregoing dimensions provide an arrangement wherein the concentrated cleaning solution can be diluted 75% with water in a ratio of 3 parts water to 1 part concentrated cleaning solution. It will be apparent to those skilled in the art that the foregoing dimensions of the various passages can be changed relative to each other to obtain any desirable flow characteristic and/or dilution of product supplied through
30 tube 51 whereby water:concentrated product ratios, e.g., 0.5:1 to 200:1, can be obtained.

-14-

The foregoing has described the principles, preferred embodiments and modes of operation of the present invention. However, the invention should not be construed as being limited to the particular embodiments discussed. Thus, the above-described embodiments should be regarded as illustrative rather than restrictive, and it should be appreciated that variations may be made in those embodiments by workers skilled in the art without departing from the scope of the present invention as defined by the following claims.

-15-

WHAT IS CLAIMED IS:

1. A portable sprayer for applying a diluted product to a surface to be treated, comprising:
 - 5 a housing having first and second inlets, first and second outlets, a mixing chamber and a valve member;
 - the first inlet supplying water to the sprayer;
 - the second inlet supplying a concentrated liquid product to the sprayer;
 - the mixing chamber being in fluid communication with the first and second inlets such that water is mixed with the concentrated liquid product to form a diluted product by feeding water through the first inlet and feeding the concentrated liquid product through the second inlet, the housing including a passage in fluid communication with the first and second inlets and second outlet, the passage including an upstream portion and a downstream portion, the second inlet being in fluid communication with the downstream portion, and the downstream portion having a larger cross section than the upstream portion so that concentrated liquid product is siphoned into the downstream portion and mixed with water supplied through the upstream portion to provide the diluted product, the diluted product being conveyed in the downstream portion without exposure to atmospheric air until the diluted product is sprayed through the second outlet;
 - 15 the first outlet spraying rinsing water from the sprayer to allow removal of diluted product from a surface to be treated;
 - the second outlet spraying the diluted product from the sprayer onto a surface to be treated; and
 - the valve member being operable to selectively feed the diluted product to the second outlet or feed rinsing water to the first outlet or prevent rinsing water from flowing to the first and second outlets.
 - 20
 - 25

AMENDED SHEET

PCT/US 96/07749
IPEA/US 30 JUN 1997

-16-

2. The sprayer of Claim 1, further comprising a container of the concentrated liquid product, the container being attached to the sprayer and the sprayer including a siphoning tube extending into the container, the second inlet being in fluid communication with the siphoning tube and the concentrated liquid product
5 being removed from the container by feeding water through the mixing chamber and siphoning the concentrated liquid product from the container.

3. The sprayer of Claim 1, further comprising a cover member attached to the housing, the cover member including first and second outlets, the first outlet of the cover member being in fluid communication with the first outlet of the housing
10 and the second outlet of the cover member being in fluid communication with the second outlet of the housing.

4. The sprayer of Claim 1, further comprising an orifice member in fluid communication with the second inlet, the orifice member including a plurality of passages therethrough which supply concentrated liquid product to the mixing
15 chamber in a substantially constant water/product ratio.

5. The sprayer of Claim 1, including an antisiphoning device in fluid communication with the first inlet, the antisiphoning device preventing flow of concentrated liquid product outwardly from the first inlet.

6. The sprayer of Claim 1, wherein the valve member comprises a
20 rotatable valve, the rotatable valve including a cylindrical body having upper and lower passages therethrough, the upper passage being in fluid communication with the first inlet and first outlet when the rotatable valve is in a first position and the lower passage being in fluid communication with the second outlet when the rotatable valve is rotated from the first position to a second position at which the upper passage is not
25 in fluid communication with the first outlet.

AMENDED SHEET

-17-

7. The sprayer of Claim 1, wherein the housing includes a bore and the valve member includes a cylindrical body fitted in the bore of the housing, the housing further including an upper passage in fluid communication with the first outlet and a lower passage in fluid communication with the second outlet, the valve member including a seal member which sealingly engages with the upper and lower passages by rotating the valve member to an off position.

8. The sprayer of Claim 1, wherein the housing includes a bore receiving the valve member, an upper passage extending between the bore and the first outlet, a second passage extending between the bore and the second outlet, and a cavity in fluid communication with the bore and the first inlet, the valve member being movable from a first position at which the cavity is in fluid communication with only the upper passage to a second position at which the cavity is only in fluid communication with the lower passage.

9. The sprayer of Claim 1, wherein the housing includes a tubular projection and a siphoning tube attached to the tubular projection, the housing including a passage in fluid communication with the siphoning tube and the second outlet.

10. The sprayer of Claim 1, wherein the mixing chamber provides a mixing ratio of water to concentrated liquid product of less than 10:1.

11. The sprayer of Claim 1, further including a tubular projection extending from the housing and a rotatable fitting mounted on the tubular projection, the rotatable fitting being engageable with a container for holding the concentrated liquid product.

AMENDED SHEET

PCT/US 96/07749
PEAUS 30 JUN 1997

-18-

12. The sprayer of Claim 1, wherein the first inlet comprises an internally threaded portion of the housing, the internally threaded portion being attachable to a garden hose by screwing the internally threaded portion onto an externally threaded portion of the garden hose.

5 13. The sprayer of Claim 1, further including a tubular projection extending from the housing and a rotatable fitting mounted on the tubular projection, the rotatable fitting being engageable with a garden hose for supplying water to the first inlet.

10 14. The sprayer of Claim 1, wherein the housing comprises a molded piece of plastic having upper and lower passages therethrough, the upper passage being in fluid communication with the first outlet and the lower passage being in fluid communication with the second outlet, the mixing chamber being located in the lower passage.

15 15. The sprayer of Claim 3, wherein the cover member includes a spray pattern member attached thereto, the spray pattern member being snapped-fitted to the cover, the first and second outlets of the cover being located on the spray pattern member.

20 16. The sprayer of Claim 1, further comprising an orifice member in fluid communication with the second inlet, the orifice member including a single passage therethrough which supplies concentrated liquid product to the mixing chamber.

17. The sprayer of Claim 2, further comprising an orifice member in fluid communication with the second inlet, the orifice member including a single passage therethrough which supplies concentrated liquid product to the mixing chamber, the orifice member including a projection fitted in the siphoning tube.

AMENDED SHEET

PCT/US 96/07749
IPEA/US 30 JUN 1997

-19-

18. The sprayer of Claim 1, wherein the mixing chamber is located in an insert supported by the housing, the insert providing a desired diluted product ratio of concentrated liquid product to water.

5 19. The sprayer of Claim 18, wherein the insert is located in a recess in the housing, the insert including a supply passage in fluid communication with the second inlet, an inlet passage in fluid communication with the first inlet and an outlet passage in fluid communication with the second outlet, the outlet passage being larger than the inlet passage and the supply passage entering the outlet passage at a location adjacent an interface between the inlet passage and the outlet passage.

10 20. The sprayer of Claim 19, wherein the outlet passage has a cross section at least 50% larger than the cross section of the inlet passage.

15 21. The sprayer of Claim 2, wherein the mixing chamber is located in an insert supported by the housing, the insert providing a desired diluted product ratio of concentrated liquid product to water, the insert including a recess receiving a free end of the siphoning tube.

20 22. The sprayer of Claim 21, wherein the insert is located in a recess in the housing, the insert including a supply passage in fluid communication with the second inlet, an inlet passage in fluid communication with the first inlet and an outlet passage in fluid communication with the second outlet, the outlet passage being larger than the inlet passage and the supply passage entering the outlet passage at a location adjacent an interface between the inlet passage and the outlet passage.

23. The sprayer of Claim 21, wherein the insert includes a suction port in fluid communication with the second inlet, the suction port supplying concentrated

PCT/US 96/07749
IPEA/US 30 JUN 1997

-20-

liquid product to the mixing chamber to provide a substantially constant water/product ratio passing through the second outlet.

24. The sprayer of Claim 21, wherein the insert includes a recess and a siphoning tube is fitted in the recess, the insert including a suction port in fluid communication with the siphoning tube and the second outlet.

25. The sprayer of Claim 21, wherein the insert provides a diluted product ratio of water to concentrated liquid product of 0.5:1 to 200:1.

26. A method of using a portable double barrel sprayer to selectively spray a water-rinse through a first outlet and spray a diluted liquid product through a second outlet, sprayer including a housing having first and second inlets, first and second outlets, a mixing chamber and a valve member; the first inlet being attached to a water hose supplying water to the sprayer; the second inlet being attached to a container supplying a concentrated liquid product to the sprayer; the mixing chamber being in fluid communication with the first and second inlets such that water is mixed with the concentrated liquid product to form a diluted product by feeding water through the first inlet and feeding the concentrated liquid product through the second inlet, the housing including a passage in fluid communication with the first and second inlets and second outlet, the passage including an upstream portion and a downstream portion, the second inlet being in fluid communication with the downstream portion, and the downstream portion having a larger cross section than the upstream portion so that concentrated liquid product is siphoned into the downstream portion and mixed with water supplied through the upstream portion to provide the diluted product, the diluted product being conveyed in the downstream portion without exposure to atmospheric air until the diluted product is sprayed through the second outlet; the first outlet spraying rinsing water from the sprayer to allow removal of diluted product from a surface to be treated; the second outlet spraying the diluted product from the

AMENDED SHEET

PCT/US 96/07749
IPEA/US 30 JUN 1997

-21-

sprayer onto a surface to be treated; and the valve member being operable to selectively feed the diluted product to the second outlet or feed rinsing water to the first outlet or prevent rinsing water from flowing to the first and second outlets,

5 mixing the concentrated liquid product with water to form a diluted product and spraying the diluted product onto a surface to be treated, the diluted product being sprayed through the second outlet of the sprayer by moving the valve member to a position at which the first and second inlets are in fluid communication with the second outlet; and

10 removing the diluted product from the surface by spraying a water-only rinse onto the surface, the water-only rinse being sprayed through the first outlet of the sprayer by moving the valve member to a position at which the first inlet is in fluid communication with the first outlet.

27. The method of Claim 26, wherein the concentrated liquid product is siphoned from the container and passes through an insert or orifice plate having one
15 or more openings therein which provides a substantially constant water/product ratio over water pressure variations in the water supplied through the inlet ranging from 40 to 60 psi.

28. The method of Claim 26, wherein the sprayer includes a housing having first and second passages, the first passage being in fluid communication with
20 the first outlet and the first inlet, the second passage being in fluid communication with the second outlet and the first and second inlets, the mixing being carried out in the second passage and the water-only rinse being supplied through the first passage.

29. The method of Claim 26, wherein the sprayer includes a housing having the first and second outlets therein and a cover mounted on the housing, the
25 cover including a first outlet in fluid communication with the first outlet of the housing and a second outlet in fluid communication with the second outlet of the

PCT/US 96/07749
IPEA/US 30 JUN 1997

-22-

housing, the first and second outlets in the cover providing different spray patterns of the water-only rinse and diluted product, respectively.

30. The method of Claim 26, wherein the valve member includes first and second passages therethrough, the first passage being in fluid communication with the first inlet and first outlet when the valve member is in the first position and the second passage being in fluid communication with the first inlet and the second outlet when the valve member is in the second position.

31. The method of Claim 26, wherein the concentrated liquid product is a concentrated liquid cleaning solution, the method comprising removing mold, mildew, algae and/or stains from an outdoor surface by applying the diluted liquid product to the outdoor surface, allowing the diluted liquid product to remain on the outdoor surface for a period of time followed by rinsing the diluted product from the outdoor surface by spraying water through the first outlet of the sprayer.

32. The method of Claim 26, wherein the concentrated liquid product is siphoned from the container and passes through an insert or orifice plate having a single opening therein.

33. The method of Claim 29, wherein the housing includes a removable spray pattern member, the first and second outlets being provided in the spray pattern member.

34. The method of Claim 26, wherein the sprayer includes a housing having the first and second outlets therein and a cover mounted on the housing, the cover including a first outlet in fluid communication with the first outlet of the housing and a second outlet in fluid communication with the second outlet of the housing, each of the first and second outlets in the cover including a tapered portion

PCT/US 96/07743
IPEA/US 30 JUN 1997

-23-

receiving the diluted product or water-only rinse sprayed through the first and second outlets of the housing.

35. The method of Claim 26, wherein the mixing chamber is located in an insert supported by the housing, the insert providing a desired diluted product ratio of concentrated liquid product to water, the insert including a supply passage in fluid communication with the second inlet, an inlet passage in fluid communication with the first inlet and an outlet passage in fluid communication with the second outlet, the outlet passage being larger than the inlet passage and the supply passage entering the outlet passage at a location adjacent an interface between the inlet passage and the outlet passage, the mixing being carried out by flowing the concentrated liquid product through the supply passage and flowing the water through the inlet passage so as to mix the concentrated liquid product with the water in the outlet passage.

36. The method of Claim 35, wherein the insert provides a diluted product ratio of water to concentrated liquid product of 0.5:1 to 200:1.

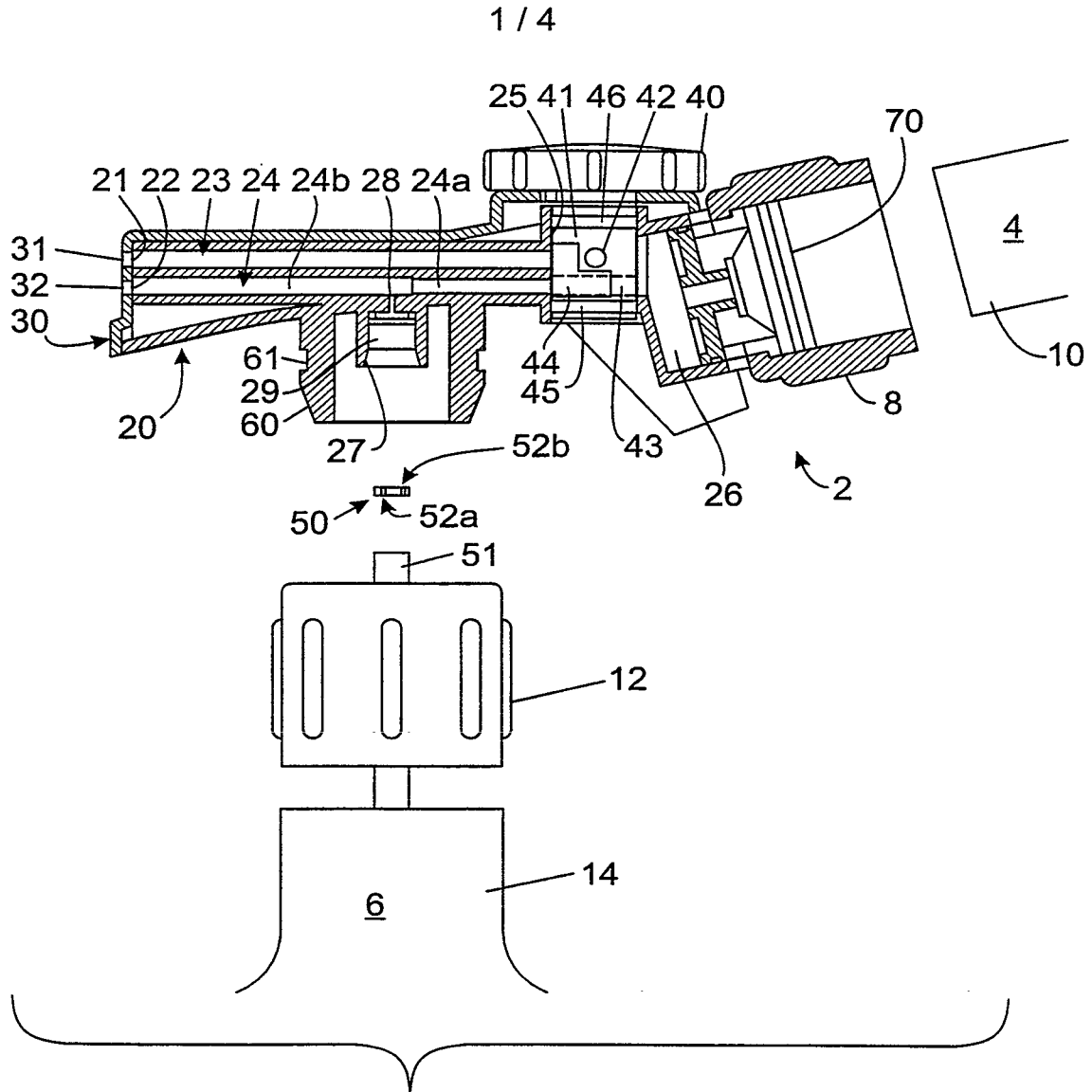

FIG. 1

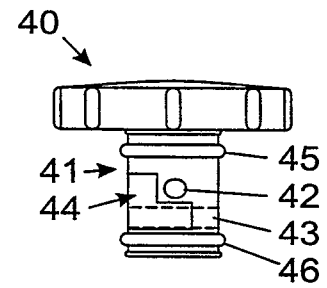
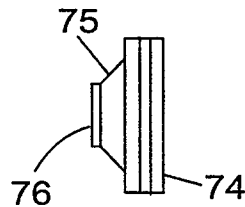
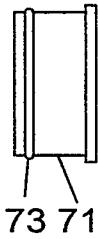
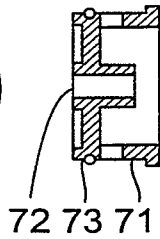
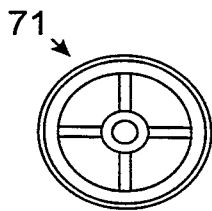

FIG. 5a

FIG. 5b

FIG. 5c

FIG. 5d

FIG. 4

2 / 4

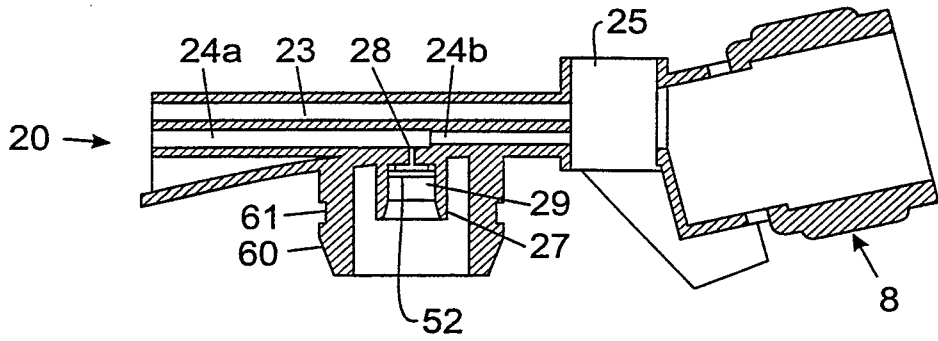

FIG. 2

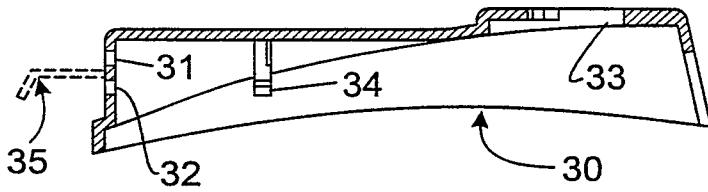

FIG. 3a

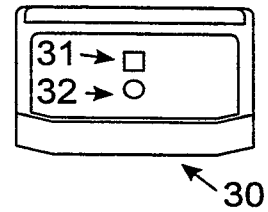

FIG. 3b

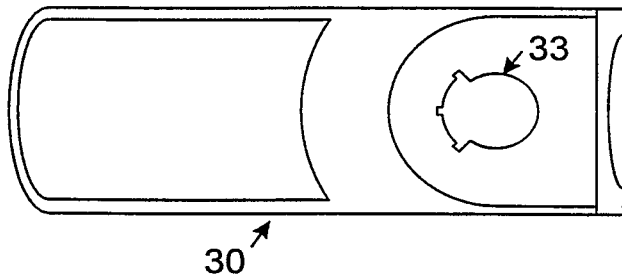

FIG. 3c

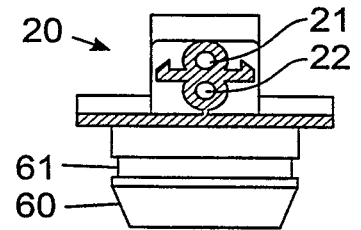

FIG. 6a

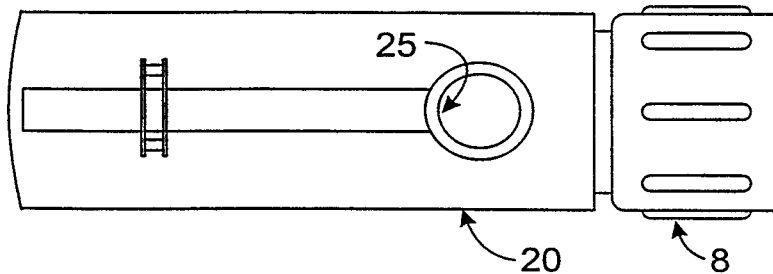

FIG. 6b

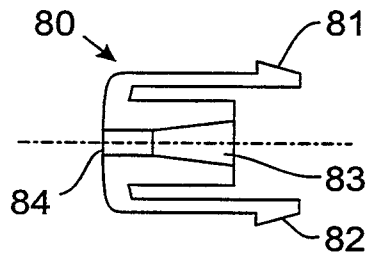

FIG. 7a

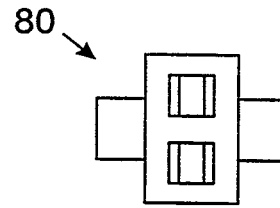

FIG. 7c

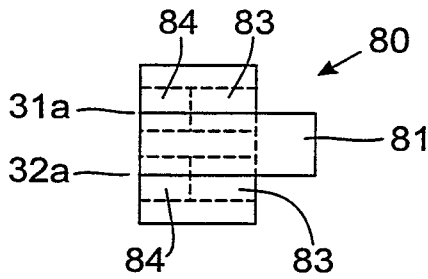

FIG. 7b

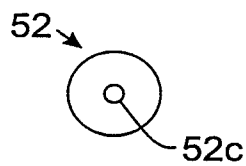

FIG. 8a

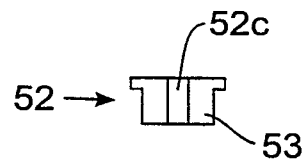

FIG. 8b

4 / 4

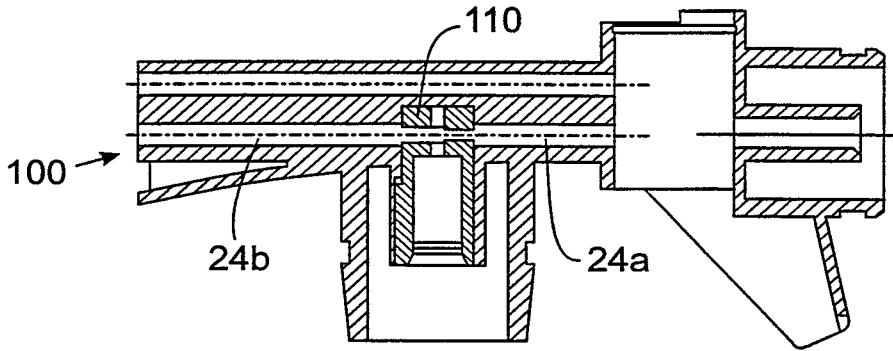

FIG. 9a

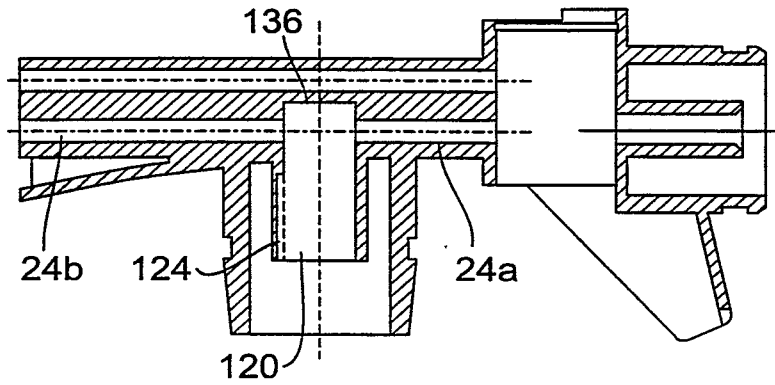

FIG. 9b

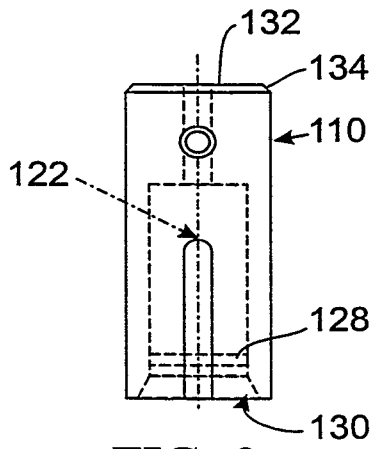

FIG. 9c

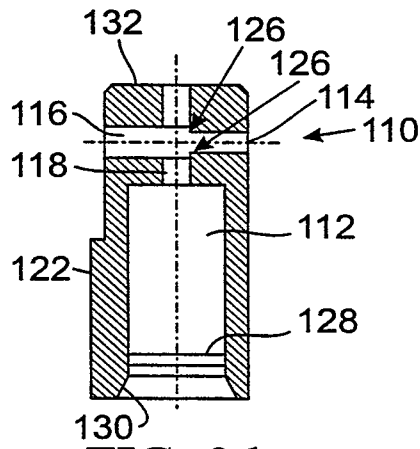

FIG. 9d

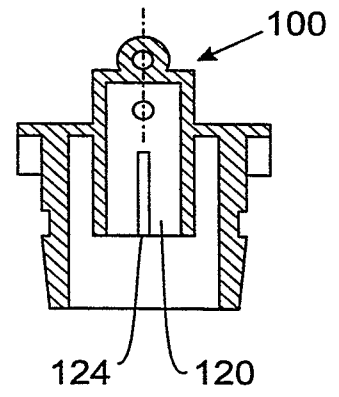

FIG. 9e

