

March 5, 1963

E. RAAMAT
CYLINDRICAL PACKAGES
Filed Dec. 15, 1960

3,080,048

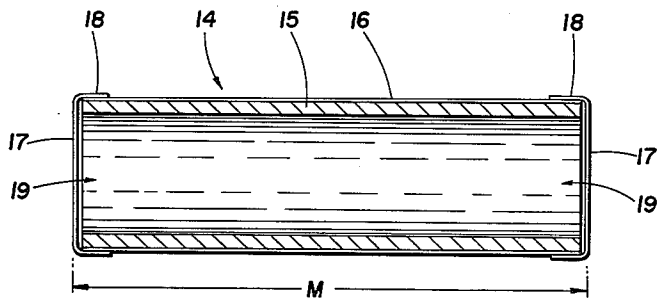

FIG. 1

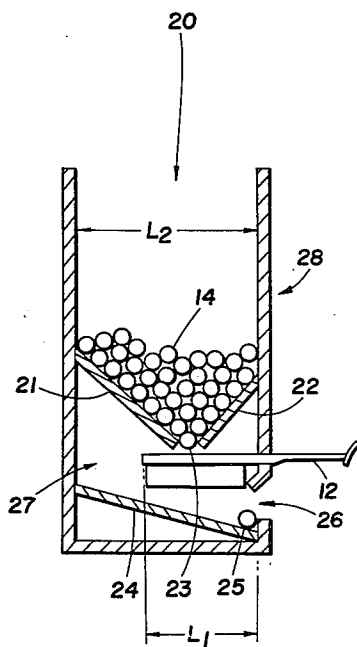

FIG. 2

Inventor

ERIC RAAMAT

by: *Cavanagh & Norman*

1

3,080,048

CYLINDRICAL PACKAGES

Eric Raamat, Scarborough, Ontario, Canada, assignor, by mesne assignments, to Superpack Vending (Curacao) N.A., Willemstad, Curacao, Netherlands Antilles, a corporation of Curacao

Filed Dec. 15, 1960, Ser. No. 75,994

8 Claims. (Cl. 206-45)

This invention relates to a cylindrical package particularly adapted for the vending of granular or flake merchandise such as soaps, foldable materials such as cloth and plastic articles of manufacture.

The packaging of soap and other large volume per unit cost merchandise has been practised heretofore substantially entirely in rectangular boxes of a variety of proportions. Having regard to the stacking of rectangular packages only, it is obvious that a maximum volume of product can be stored in a vertical stack of rectangular packages as compared with any other geometric form of package.

In considering the dispensing of packages of the prior art from a vertical stack in such manner that a magazine is filled with the packages in vertical stacked relationship, the mechanical mechanism necessary to extract a package may be so designed as to reciprocate on a path at least equal to one transverse dimension of a package when stacked. This is well established in the know-how of the dispensing arts. However, it is impractical from a merchandising point of view to provide a magazine holding a stack of rectangular packages for the dispensing of soap for example. For each dispensing mechanism the magazine must be of very great height to accommodate a reasonable number of packages. Accordingly, it is necessary to multiply the dispensing mechanism and magazine in plural form to such a degree that the dispensing concept particularly if associated with a vending mechanism is rendered impractical having regard to the efforts required to recharge the magazines as well as the substantial floor space involved.

It is not possible in the practical sense to provide a vending mechanism which will enable rectangular article storage magazines to be located in depth, that is, one behind the other. In spite of attempts made in the prior art, there does not appear to be a reliable mechanism available for selecting articles from the magazines in sequence. A rectangular article is not self-feeding or self-movable except in a vertical direction under the influence of gravity. Nor have magazine designs been proposed in the prior art which would enable selective self-feeding from a plurality of vertical magazines to a common point with rectangular articles unless a transfer mechanism is employed. The utilization of a transfer mechanism due to general lack of reliability and the expense involved, does not permit its employment in mechanisms to be operated by the general public.

It is accordingly, the main object of this invention to provide a package form adapting the sale of granular and pliable sheet products for sale by the use of dispensing apparatus and especially vending mechanisms in such manner as to avoid the aforementioned prior art disadvantages.

Other objects will be apparent from a study of the following specification taken into conjunction with the accompanying drawings.

In the drawings:

FIGURE 1 is a sectional view of a preferred form of package according to the invention;

FIGURE 2 is a sectional diagrammatic illustration of a preferred form of dispensing mechanism for the package of FIGURE 1 and embracing therewith a concept of the invention herein.

2

Attempts to provide a transfer mechanism which will distribute from plural magazines to a single dispensing mechanism have been proposed but are not suited to the vending of large volume per unit cost products because of their expense and lack of reliability.

It is a part of the concept of this invention that if the package can be provided in such shape as to effect its own transfer to a dispensing position, a transfer mechanism may be eliminated and in addition the magazine may be enlarged laterally rather than vertically to accommodate a much greater volume of merchandise for a given height even though the package shape desirable may be less efficient in its volume content.

Accordingly the present invention contemplates the general form illustrated in FIGURE 1 and generally designated by numeral 14 in which the package is given its rigid character by a paper tube 15 of cylindrical form. The tube is sealed by providing there-about a plastic film such as a polyethylene film 16 to which disc like ends 17 of polyethylene film are heat sealed as at the over-lapping flange portion 18 to effect sealed closure thus to contain a product within the tube 15.

The structure of the packaging cylinder or cylindrical container of the present invention is such that the rigid inner body 15 formed of a cheap paper base material that is to say, a fibrous material, comprises in excess of about 70% of the total weight of the package when empty. It has been found that a very light weight plastic film may be employed for sealing the package and as indicated may be in the form of a polyethylene sheet material extending entirely over the exterior surfaces and ends of the tube 15. Preferably the weight of the tube in relation to the weight of the entire package structure when empty should be in excess of 90% of the total weight but less than about 96% having regard to the necessary weight of plastic film or sheet required to seal the end openings 19 of tube 15 with sufficient rigidity and strength to retain the package product therein.

Now referring to FIGURE 2 it will be apparent that by providing a chute or bin like structure 20 having downwardly converging guide walls 21 and 22 adapted to deliver the cylindrical objects or packages 14 to the dispensing point 23, the vending mechanism 12 may deliver a package at a time to the ramp 24 to cause the dispensed article to roll to a retrieving position 25 at the opening 26 of the dispensing mechanism structure 27. The form of magazine 28 may be a suitable upward continuation of the walls 21 and 22 having regard to the length dimension M of the package 14 shown in FIGURE 1. Thus the dimension L₁ of the magazine 28 is not restricted by the dimensions of the package according to this invention. Nor is it restricted by the dimensions or available actuating motion of the vending mechanism 12.

It will be apparent that the article and dispensing mechanism of the invention enables the dispensing of a large volume of a product with a single dispensing mechanism without resorting to transfer mechanisms or multiple magazine structures. While cylindrical containers have been proposed heretofore for the packaging of merchandise and applicant herein is aware of the existence of cylindrical containers of various kinds, applicant's machine dispensable container is of a general character and form in association with dispensing mechanisms different from that of the prior art to a degree enabling the merchandising of products of low cost per unit volume adaptable for machine delivery to the general public.

Having regard to the foregoing it will be appreciated that the invention in its broader aspects embodies a self-feeding merchandising package adapted to be dispensed by conventional dispensing mechanisms and comprising a hollow cylindrical body formed of fibrous material and

3

adapted to contain the merchandise therewithin. Preferably the package embodies 70% by weight of fibrous material the remainder being substantially a plastic material sealably extending over the entire exterior surfaces of the fibrous cylindrical tube and the ends thereof to seal merchandise therein.

What I claim is:

1. A self-feeding merchandising package adapted to be dispensed by conventional dispensing mechanisms and comprising: a hollow cylindrical open ended body formed of fibrous material and containing the merchandise therewithin; a plastic film extending entirely over the exterior surfaces of said body; and plastic end closures of thin flexible plastic sheet material on each said open end bonded to said plastic film on said body in a marginal area around each said open end, said closure in the area of said bonding being shaped to fit around and conform to the contour of said body to sealably contain the merchandise therein and being manually tearable to permit access to said merchandise.

2. A self-feeding merchandising package adapted to be dispensed by conventional dispensing mechanisms and comprising: a hollow cylindrical open ended body formed of fibrous material and containing the merchandise therewithin; a plastic film extending entirely over the exterior surfaces of said body; and plastic end closures of thin flexible plastic sheet material on each said open end bonded to said plastic film on said body in a marginal area around each said open end, said closure in the area of said bonding being shaped to fit around and conform to the contour of said body to sealably contain the merchandise therein and being manually tearable to permit access to said merchandise, the proportion of fibrous material being in excess of 70% by weight of said fibrous material and said plastic material together.

3. A self-feeding merchandising package adapted to be dispensed by conventional dispensing mechanisms and comprising: a hollow cylindrical open-ended body formed of fibrous material and containing the merchandise therewithin; a polyethylene film extending entirely over the exterior surfaces of said body; and plastic end closures of thin flexible plastic sheet material on each said open end bonded to said plastic film on said body in a marginal area around each said open end, said closure in the area of said bonding being shaped to fit around and conform to the contour of said body to sealably contain the merchandise therein and being manually tearable to permit access to said merchandise.

4. A self-feeding merchandising package adapted to be dispensed by conventional dispensing mechanisms and comprising: a hollow cylindrical open ended body formed of fibrous material and containing the merchandise therewithin; a polyethylene film extending entirely over the exterior surfaces of said body; and plastic end closures of thin flexible plastic sheet material on each said open end bonded to said plastic film on said body in a marginal area around each said open end, said closure in the area of said bonding being shaped to fit around and conform to the contour of said body to sealably contain the merchandise therein and being manually tearable to permit access to said merchandise, the proportion of fibrous material being in excess of 70% by weight of said fibrous material and said polyethylene material together.

5. A self-feeding merchandising package adapted to be dispensed by conventional dispensing mechanisms and comprising: a hollow cylindrical open ended body formed of rigid paper material and containing the merchandise

4

therewithin; a plastic film extending entirely over the exterior surfaces of said body; and plastic end closures of thin flexible plastic sheet material on each said open end bonded to said plastic film on said body in a marginal area around each said open end, said closure in the area of said bonding being shaped to fit around and conform to the contour of said body to sealably contain the merchandise therein and being manually tearable to permit access to said merchandise.

6. A self-feeding merchandising package adapted to be dispensed by conventional dispensing mechanisms and comprising: a hollow cylindrical open ended body formed of rigid paper material and containing the merchandise therewithin; a plastic film extending entirely over the exterior surfaces of said body; and plastic end closures of thin flexible plastic sheet material on each said open end bonded to said plastic film on said body in a marginal area around each said open end, said closure in the area of said bonding being shaped to fit around and conform to the contour of said body to sealably contain the merchandise therein and being manually tearable to permit access to said merchandise, the proportion of rigid paper material being in excess of 70% by weight of said rigid paper material and said plastic material together.

7. A self-feeding merchandising package adapted to be dispensed by conventional dispensing mechanisms and comprising: a hollow cylindrical open ended body formed of rigid paper material and containing the merchandise therewithin; a polyethylene film extending entirely over the exterior surfaces of said body; and plastic end closures of thin flexible plastic sheet material on each said open end bonded to said plastic film on said body in a marginal area around each said open end, said closure in the area of said bonding being shaped to fit around and conform to the contour of said body to sealably contain the merchandise therein and being manually tearable to permit access to said merchandise.

8. A self-feeding merchandising package adapted to be dispensed by conventional dispensing mechanisms and comprising: a hollow cylindrical open-ended body formed of rigid paper material and containing the merchandise therewithin; a polyethylene film extending entirely over the exterior surfaces of said body; and plastic end closures of thin flexible plastic sheet material on each said open end bonded to said plastic film on said body in a marginal area around each said open end, said closure in the area of said bonding being shaped to fit around and conform to the contour of said body to sealably contain the merchandise therein and being manually tearable to permit access to said merchandise, the proportion of rigid paper material being in excess of 70% by weight of said rigid paper material and said polyethylene material together.

References Cited in the file of this patent

UNITED STATES PATENTS

647,187	Knapp	Apr. 10, 1900
1,310,185	Gossom	July 15, 1919
2,268,245	Davis	Dec. 30, 1941
2,393,347	Stuart et al.	Jan. 22, 1946
2,691,474	Olson	Oct. 12, 1954
2,808,192	Raisin	Oct. 1, 1957
2,885,105	Heyl et al.	May 5, 1959
2,937,744	Olson	May 24, 1960
2,975,074	Jankens et al.	Mar. 14, 1961

FOREIGN PATENTS

705,816	Great Britain	Mar. 17, 1954
---------	---------------	---------------